

# ***STORMWATER POLLUTION PREVENTION PLAN***

***National Pollution Discharge Elimination System***

***Prepared for:  
Hillcrest Addition***

July 2024

Volume No. 1  
Copy 1 of 4



Prepared by:  
LEMONS ENGINEERING CONSULTANTS, INC.

204 CHERRY STREET  
CABOT, AR 72023  
(501) 843-5081  
(501) 941-0959 Fax

# *Table of Contents*

## **General**

- Nature of Activity

## **Site Evaluation & Design Development**

- Collection of Site Description
  - Site Location
  - Intended Sequence of Major Construction Activities
  - Site Plan Development – Acreage
  - Computed Runoff Coefficient
  - Soils Data
- Responsible Parties
  - General Contractor
  - Inspector
- Receiving Waters
- Water Quality Standard
- Endangered Species

## **Attachment ‘A’**

## **Attachment ‘B’**

## **Attachment ‘C’**

## **Control Selection & Plan Design**

- Erosion & Sediment Controls
- Other Controls
- Non-Stormwater Discharges
- Post-Construction Stormwater Management Controls
- State & Local Plans

## **Assessment**

## **Attachment ‘D’**

## **Inspection & Maintenance Plan**

- Inspection Form
- Contractors Certification
- Inspectors Certification
- Plan Certification

## **Supplemental Stormwater Pollution Prevention Plan Details**

## **Notice of Intent**

## *General*

### *Nature of Activity*

Hillcrest Addition is a residential development located off Springhill Road, in Bryant, Saline County, Arkansas. The developer and permittee of this project is:

Springhill Hwy 5 Developments LLC  
816 East Oak Street  
Conway, Arkansas 72032

The target timeline for this project is to have construction completed by August 2025.

Of course, the main purpose of activity to be covered under this Storm Water Pollution Prevention Plan is found in the construction necessary for the development of this project. Erosion control and sedimentation protection will be the main target of this Plan.

# *Site Evaluation & Design Development*

## *Collection of Site Description*

### **Site Location**

A legal description of Hillcrest Addition and the pre-construction contours of this project are provided on Attachment 'A'. This is a residential planned unit development site w/this construction.

### **Intended Sequence of Major Construction Activities**

- 1.) Provide clearing and grubbing of the construction area
- 2.) Provide erosion and sediment control (silt fencing) in areas where required
- 3.) Install utilities and permanent storm drainage items (more specifically storm water, sanitary sewer and water)
- 4.) Rough cut streets to near sub grade elevation
- 5.) Install sedimentation barriers at all curb inlets
- 6.) Provide undercutting of streets where applicable
- 7.) Upon completion of utilities, install concrete curb and gutter on streets
- 8.) Install gravel sub-base (complete set-up)
- 9.) Complete construction of utilities
- 10.) Begin seeding/sodding of disturbed areas
- 11.) Remove silt fencing as needed
- 12.) Complete street construction
- 13.) Once stabilization is complete, remove remaining erosion and sediment control measures

### **Site Plan Development-Acreage**

The goal of this Storm Water Pollution Prevention Plan is to minimize the amount of vegetation to be disturbed; to minimize the amount of cut and fill to be moved; and to limit the impact construction may have on steep slopes, erodible soils, and existing drainage facilities. The nature of the construction activity for this project shall be related to the clearing and grubbing of the project area. Utilities to be placed in this development include: water, sewer and storm water. These utilities will be placed on grades as specified by the engineered plans (where applicable). The plans pertaining to the construction of utilities are available for review in the office of Lemons



Engineering Consultants, Inc. The disturbance of soils within the project area will be from construction as pertaining to clearing and grubbing, excavation, stockpiling, rough grading, final grading, preparation for seeding and sod (where applicable), and excavation for trenches as pertaining to utilities, drainage structures and swales.

Total Acres: 4.89 ac

Total Disturbed Acres: 4.89 ac

### **Computed Runoff Coefficient**

For the 'lotted' areas, the following assumptions were made:

For paved areas (drives, roofs, etc.)	C = 0.90 (Existing & Proposed)
For unpaved areas (grass, landscaping, etc.)	C = 0.35 (Existing)
	C = 0.22 (Proposed)

Existing Site Conditions:

Area Runoff Coefficient = 0.35

Proposed Site Conditions:

Area Runoff Coefficient = 0.40

### **Soils Data**

According to the "Soil Survey of Saline County, Arkansas", prepared by the United States Department of Agriculture, Soil Conservation Service in cooperation with the Arkansas Agricultural Experiment Station (issued April 1979), soil in Hillcrest Addition is 100 percentage of Carnasaw-Townley Association (9), undulating slopes (see Attachment 'B' on the next page). Under Table 8 – Woodland Management and Productivity, Carnasaw-Townley Association provides only a slight risk as pertaining to "erosion hazard"; Table 12 – Water Management, "Grassed Waterways" percs slowly, slope in Carnasaw soil classifications and droughty, rooting depth, slope in Townley soil classifications. Under Table 14 – Wildlife Habitat Potentials, Carnasaw-Townley Association is good for grasses and legumes, wild herbaceous plants, hardwood trees, coniferous plants, and both openland wildlife and woodland wildlife.

### **Responsible Parties**

General Contractor: Lance Massey  
816 East Oak Street  
Conway, Arkansas 72032

Inspector: Lance Massey  
816 East Oak Street  
Conway, Arkansas 72032

### **Name of Stream Which Will Receive Runoff**

According to the Congo Quadrangle Map, as published by the U.S. Geological Survey, and the City of Bryant FIRM (Community Panel No 05125C0225E, June 5, 2020); Unnamed tributary of Hurricane Lake is the receiving water; thence into Hurricane Lake; thence into Hurricane Creek; thence into the Saline River; the Saline River eventually empties into the Ouachita River. Attention is called to Attachment 'C' on the following page, which shows the project as depicted on said Quadrangle Map.

### **Water Quality Standard**

There are no specific requirements for Water quality standards, however the contractor will assure any necessary measures to ensure that any discharges do not cause or contribute to an excursion above any applicable water quality standards. Saline River is listed on the Arkansas water quality limited Waterbodies (streams) - 2020 303(d) list for Lead, Temperature, Turbidity, and Dissolved Oxygen and the 2020 303(d) list 4a (streams) for Mercury. In the event that specific water quality standards or TMDL's are specified by ADEQ, City of Bryant, or any other governing authority, the contractor shall adjust the erosion controls as needed to meet the applicable standard and provide documentation discharges where required.

### **Endangered Species**

According to the US Fish & Wildlife, this property has nine endangered species in proximity of the storm water discharge and BMP's will be constructed to control storm water runoff. The project does not effect any proposed or established critical habitats for any of these nine species.



## United States Department of the Interior



FISH AND WILDLIFE SERVICE  
Arkansas Ecological Services Field Office  
110 South Amity Suite 300  
Conway, AR 72032-8975  
Phone: (501) 513-4470 Fax: (501) 513-4480

In Reply Refer To:  
Project Code: 2024-0113660  
Project Name: Hillcrest Addition

07/09/2024 21:12:42 UTC

Subject: List of threatened and endangered species that may occur in your proposed project location or may be affected by your proposed project

### To Whom It May Concern:

The enclosed species list identifies threatened, endangered, proposed and candidate species, as well as proposed and final designated critical habitat, that may occur within the boundary of your proposed project and/or may be affected by your proposed project. The species list fulfills the requirements of the U.S. Fish and Wildlife Service (Service) under section 7(c) of the Endangered Species Act (Act) of 1973, as amended (16 U.S.C. 1531 *et seq.*).

New information based on updated surveys, changes in the abundance and distribution of species, changed habitat conditions, or other factors could change this list. Please feel free to contact us if you need more current information or assistance regarding the potential impacts to federally proposed, listed, and candidate species and federally designated and proposed critical habitat. Please note that under 50 CFR 402.12(e) of the regulations implementing section 7 of the Act, the accuracy of this species list should be verified after 90 days. This verification can be completed formally or informally as desired. The Service recommends that verification be completed by visiting the IPaC website at regular intervals during project planning and implementation for updates to species lists and information. An updated list may be requested through the IPaC system by completing the same process used to receive the enclosed list.

The purpose of the Act is to provide a means whereby threatened and endangered species and the ecosystems upon which they depend may be conserved. Under sections 7(a)(1) and 7(a)(2) of the Act and its implementing regulations (50 CFR 402 *et seq.*), Federal agencies are required to utilize their authorities to carry out programs for the conservation of threatened and endangered species and to determine whether projects may affect threatened and endangered species and/or designated critical habitat.

A Biological Assessment is required for construction projects (or other undertakings having similar physical impacts) that are major Federal actions significantly affecting the quality of the human environment as defined in the National Environmental Policy Act (42 U.S.C. 4332(2) (c)). For projects other than major construction activities, the Service suggests that a biological

evaluation similar to a Biological Assessment be prepared to determine whether the project may affect listed or proposed species and/or designated or proposed critical habitat. Recommended contents of a Biological Assessment are described at 50 CFR 402.12.

If a Federal agency determines, based on the Biological Assessment or biological evaluation, that listed species and/or designated critical habitat may be affected by the proposed project, the agency is required to consult with the Service pursuant to 50 CFR 402. In addition, the Service recommends that candidate species, proposed species and proposed critical habitat be addressed within the consultation. More information on the regulations and procedures for section 7 consultation, including the role of permit or license applicants, can be found in the "Endangered Species Consultation Handbook" at:

<https://www.fws.gov/sites/default/files/documents/endangered-species-consultation-handbook.pdf>

**Migratory Birds:** In addition to responsibilities to protect threatened and endangered species under the Endangered Species Act (ESA), there are additional responsibilities under the Migratory Bird Treaty Act (MBTA) and the Bald and Golden Eagle Protection Act (BGEPA) to protect native birds from project-related impacts. Any activity, intentional or unintentional, resulting in take of migratory birds, including eagles, is prohibited unless otherwise permitted by the U.S. Fish and Wildlife Service (50 C.F.R. Sec. 10.12 and 16 U.S.C. Sec. 668(a)). For more information regarding these Acts see <https://www.fws.gov/program/migratory-bird-permit/what-we-do>.

The MBTA has no provision for allowing take of migratory birds that may be unintentionally killed or injured by otherwise lawful activities. It is the responsibility of the project proponent to comply with these Acts by identifying potential impacts to migratory birds and eagles within applicable NEPA documents (when there is a federal nexus) or a Bird/Eagle Conservation Plan (when there is no federal nexus). Proponents should implement conservation measures to avoid or minimize the production of project-related stressors or minimize the exposure of birds and their resources to the project-related stressors. For more information on avian stressors and recommended conservation measures see <https://www.fws.gov/library/collections/threats-birds>.

In addition to MBTA and BGEPA, Executive Order 13186: *Responsibilities of Federal Agencies to Protect Migratory Birds*, obligates all Federal agencies that engage in or authorize activities that might affect migratory birds, to minimize those effects and encourage conservation measures that will improve bird populations. Executive Order 13186 provides for the protection of both migratory birds and migratory bird habitat. For information regarding the implementation of Executive Order 13186, please visit <https://www.fws.gov/partner/council-conservation-migratory-birds>.

We appreciate your concern for threatened and endangered species. The Service encourages Federal agencies to include conservation of threatened and endangered species into their project planning to further the purposes of the Act. Please include the Consultation Code in the header of this letter with any request for consultation or correspondence about your project that you submit to our office.

Attachment(s):

- Official Species List

## **OFFICIAL SPECIES LIST**

This list is provided pursuant to Section 7 of the Endangered Species Act, and fulfills the requirement for Federal agencies to "request of the Secretary of the Interior information whether any species which is listed or proposed to be listed may be present in the area of a proposed action".

This species list is provided by:

**Arkansas Ecological Services Field Office**  
110 South Amity Suite 300  
Conway, AR 72032-8975  
(501) 513-4470

## PROJECT SUMMARY

Project Code: 2024-0113660

Project Name: Hillcrest Addition

Project Type: Residential Construction

Project Description: Residential Subdivision in Bryant, Saline County, AR

Project Location:

The approximate location of the project can be viewed in Google Maps: <https://www.google.com/maps/@34.63142910000005,-92.51751319346704,14z>

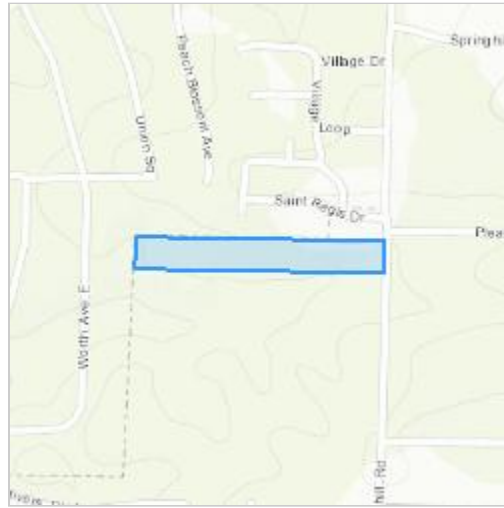

Counties: Saline County, Arkansas

## ENDANGERED SPECIES ACT SPECIES

There is a total of 9 threatened, endangered, or candidate species on this species list.

Species on this list should be considered in an effects analysis for your project and could include species that exist in another geographic area. For example, certain fish may appear on the species list because a project could affect downstream species. Note that 1 of these species should be considered only under certain conditions.

IPaC does not display listed species or critical habitats under the sole jurisdiction of NOAA Fisheries<sup>1</sup>, as USFWS does not have the authority to speak on behalf of NOAA and the Department of Commerce.

See the "Critical habitats" section below for those critical habitats that lie wholly or partially within your project area under this office's jurisdiction. Please contact the designated FWS office if you have questions.

- 
1. [NOAA Fisheries](#), also known as the National Marine Fisheries Service (NMFS), is an office of the National Oceanic and Atmospheric Administration within the Department of Commerce.

## MAMMALS

NAME	STATUS
Northern Long-eared Bat <i>Myotis septentrionalis</i> No critical habitat has been designated for this species. This species only needs to be considered under the following conditions: <ul style="list-style-type: none"> <li>This species only needs to be considered if the project includes wind turbine operations.</li> </ul> Species profile: <a href="https://ecos.fws.gov/ecp/species/9045">https://ecos.fws.gov/ecp/species/9045</a>	Endangered

## BIRDS

NAME	STATUS
Eastern Black Rail <i>Laterallus jamaicensis ssp. jamaicensis</i> No critical habitat has been designated for this species. Species profile: <a href="https://ecos.fws.gov/ecp/species/10477">https://ecos.fws.gov/ecp/species/10477</a>	Threatened
Piping Plover <i>Charadrius melodus</i> Population: [Atlantic Coast and Northern Great Plains populations] - Wherever found, except those areas where listed as endangered. There is <b>final</b> critical habitat for this species. Your location does not overlap the critical habitat. Species profile: <a href="https://ecos.fws.gov/ecp/species/6039">https://ecos.fws.gov/ecp/species/6039</a>	Threatened
Rufa Red Knot <i>Calidris canutus rufa</i> There is <b>proposed</b> critical habitat for this species. Species profile: <a href="https://ecos.fws.gov/ecp/species/1864">https://ecos.fws.gov/ecp/species/1864</a>	Threatened

## REPTILES

NAME	STATUS
Alligator Snapping Turtle <i>Macrochelys temminckii</i> No critical habitat has been designated for this species. Species profile: <a href="https://ecos.fws.gov/ecp/species/4658">https://ecos.fws.gov/ecp/species/4658</a>	Proposed Threatened

## CLAMS

NAME	STATUS
Ouachita Fanshell <i>Cyprogenia sp. cf. aberti</i> There is <b>final</b> critical habitat for this species. Your location does not overlap the critical habitat. Species profile: <a href="https://ecos.fws.gov/ecp/species/10889">https://ecos.fws.gov/ecp/species/10889</a>	Threatened
Pink Mucket (pearlymussel) <i>Lampsilis abrupta</i> No critical habitat has been designated for this species. Species profile: <a href="https://ecos.fws.gov/ecp/species/7829">https://ecos.fws.gov/ecp/species/7829</a>	Endangered
Winged Mapleleaf <i>Quadrula fragosa</i> Population: Wherever found, except where listed as an experimental population No critical habitat has been designated for this species. Species profile: <a href="https://ecos.fws.gov/ecp/species/4127">https://ecos.fws.gov/ecp/species/4127</a>	Endangered



## INSECTS

NAME	STATUS
Monarch Butterfly <i>Danaus plexippus</i> No critical habitat has been designated for this species. Species profile: <a href="https://ecos.fws.gov/ecp/species/9743">https://ecos.fws.gov/ecp/species/9743</a>	Candidate

## CRITICAL HABITATS

THERE ARE NO CRITICAL HABITATS WITHIN YOUR PROJECT AREA UNDER THIS OFFICE'S JURISDICTION.

YOU ARE STILL REQUIRED TO DETERMINE IF YOUR PROJECT(S) MAY HAVE EFFECTS ON ALL ABOVE LISTED SPECIES.

## **IPAC USER CONTACT INFORMATION**

Agency: Lemons Engineering Consultants

Name: Erica Burke

Address: 204 West Cherry Street

City: Cabot

State: AR

Zip: 72023

Email: eburke@lemonsengineering.com

Phone: 5016057665

**LEGAL DESCRIPTION:**

PART OF THE SE 1/4, OF THE SE 1/4, SECTION 17, T-1-S, R-14-W, SALINE COUNTY, ARKANSAS, BEING MORE PARTICULARLY DESCRIBED AS FOLLOWS:

COMMENCING AT THE SOUTHEAST CORNER OF THE SE 1/4, OF THE SE 1/4, SECTION 17, T-1-S, R-14-W, SALINE COUNTY, ARKANSAS; THENCE N 02°17'33" E, 1167.19 FEET TO THE POINT OF BEGINNING; THENCE N 88°34'40" W, 1344.97 FEET; THENCE N 01°36'19" E, 167.98 FEET; THENCE S 87°44'58" E, 1346.85 FEET; THENCE S 02°18'02" W, 148.52 FEET; TO THE POINT OF BEGINNING, CONTAINING 4.89 ACRES, MORE OR LESS.

**FLOOD CERTIFICATION:**

BASED UPON REVIEW OF THE FEDERAL EMERGENCY MANAGEMENT AGENCY, FIRM COMMUNITY PANEL NO. 0512500225E, EFFECTIVE DATE: JUNE 5, 2020 THE PROPERTY DEPICTED ON THIS PLAT IS LOCATED WITHIN ZONE X, AREAS DETERMINED TO BE OUTSIDE THE 0.2% ANNUAL CHANCE FLOODPLAIN.



**VICINITY MAP**  
SCALE: 1" = 2000'

LEMONS ENGINEERING CONSULTANTS, INC.  
201 CHERRY STREET  
CABOT, ARKANSAS 72023  
(501) 843-5081 • Fax (501) 941-0959  
**ENGINEERING + SURVEYING**  
WATER • SEWER • TRANSPORTATION • SUBDIVISIONS

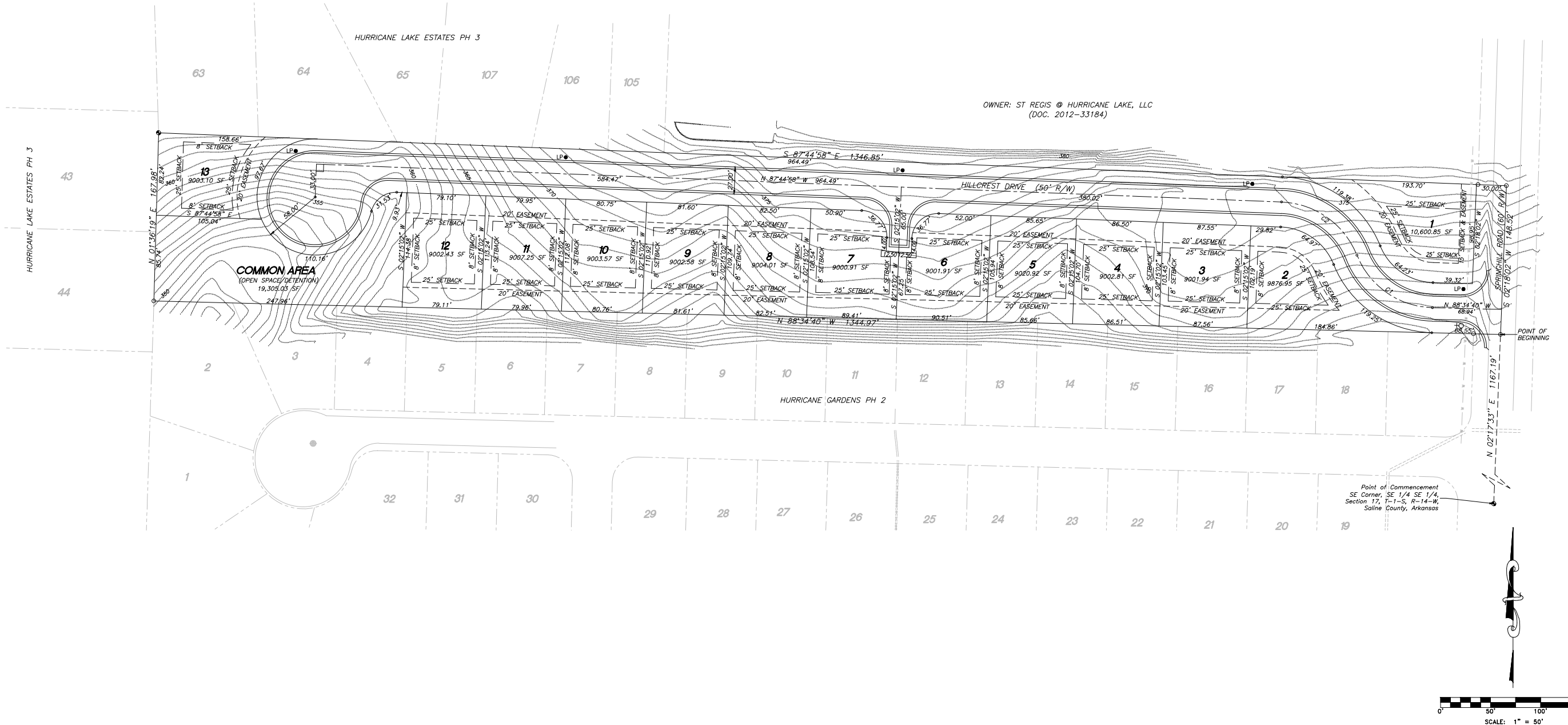

**ATTACHMENT A**  
**HILLCREST ADDITION**  
PART OF THE SE 1/4 OF SECTION 17, T-1-S, R-14-W  
CITY OF BRYANT, SALINE COUNTY, ARKANSAS

Project For:  
Springhill Hwy 5  
Development, LLC  
816 E. Oak Street  
Conway, Arkansas 72032

Project No.	Date	Revisions	No.	By	Date
24-018	JULY 9, 2024				
Attachment A					
Scale:	1" = 50'				
Drawn By:	B. Judd				
Sheet:	1 of 1				

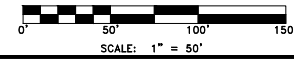

Custom Soil Resource Report  
Soil Map (Hillcrest Addition - Bryant)



Soil Map may not be valid at this scale.

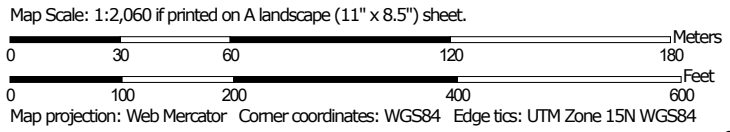



# Attachment C

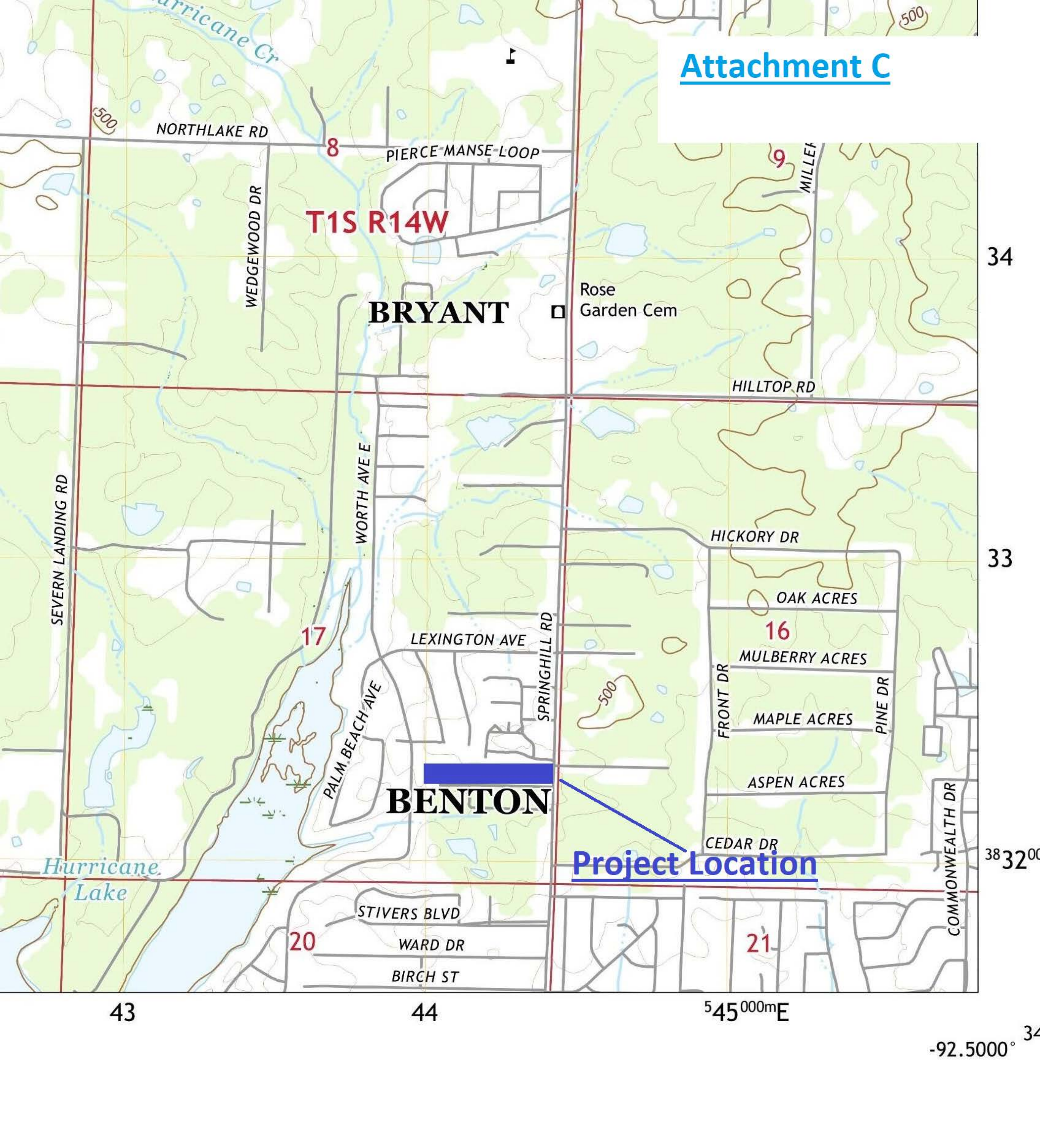

**T1S R14W**

**BRYANT**

Rose Garden Cem

**BENTON**

**Project Location**

43

44

45 000mE

-92.5000° 34

34

33

32 00



## *Control Selection & Plan Design*

### **Erosion & Sediment Controls**

Erosion and sediment controls include stabilization measures for disturbed areas and structural controls to divert runoff and remove sediment. Erosion and sediment controls are implemented during the construction period to prevent and/or control the loss of soil from the construction site into the receiving waters. Any and all inadequate controls shall be replaced, and all off-site accumulations shall be removed at a frequency sufficient to minimize off-site impacts. Erosions and sediment controls include temporary or permanent measures, including, but not limited to:

- Areas of permanent seeding
- Areas of sod stabilization
- Silt fence
- Rock barriers
- Earth dikes
- Drainage swales
- Storm drain – inlet protection
- Temporary & permanent sediment barriers
- Slope Drains

Attention is called to the following pages which provide specifications and typical section for each of these measures. These pages shall further illustrate the when and why specific control measures are used. These specifications accompany the Erosion Control and Stormwater Management Plan as shown on the attached Attachments.

Stabilization measures shall be initiated as soon as practicable in portions of the site where construction activities have temporarily or permanently ceased, but in no case more than 14 days after the construction activity in that portion of the site has temporarily or permanently ceased, except where the initiation of stabilization measures by the 14<sup>th</sup> day after construction activity temporarily or permanently ceases is precluded by snow cover, stabilization measures shall be initiated as soon as practicable or where construction activity will resume on a portion of the site within 14 days from when activities ceased, then stabilization measure do not have to be initiated on that portion of the site by the 14<sup>th</sup> day after construction activity temporarily ceased.

**Other Controls**

If erosion & sediment controls indicate that they have been used inappropriately or incorrectly, they are to be replaced or modified to control the site appropriately or correctly. Any off-site sediment shall be removed immediately to minimize any off-site impacts. The contractor shall obtain permission from property owner prior to clean-up of the off-site sediment. When sediment ponds or traps have reached 50% capacity, the sediment shall be removed.

Solid waste which can be burned on-site such as trees, shrubs, brush, and wooden material shall be burned in accordance with local City or County Code. The contractor shall obtain the necessary permit to perform such activity. Additional solid waste that is not suitable for on-site burning such as plastics, foam packaging, PVC pipe scraps, shall be collected in a central location designated by the contractor and placed in appropriated containers (dumpsters or garbage cans) for disposal. No solid materials, including building materials, shall be discharged to waters of the State. Contractor shall coordinate with the local municipality or waste disposal service to arrange for pickup and disposal of this waste at an approved off-site location. There will not be any off-site storage with this project.

Date when major grading activities occurred: \_\_\_\_\_

Date when construction activities ceased:

Date \_\_\_\_\_ Area \_\_\_\_\_ temporarily or permanently

Date \_\_\_\_\_ Area \_\_\_\_\_ temporarily or permanently

Date when an area is stabilized:

Date \_\_\_\_\_ Area \_\_\_\_\_ temporarily or permanently

Stabilization practice used \_\_\_\_\_

Date \_\_\_\_\_ Area \_\_\_\_\_ temporarily or permanently

Stabilization practice used \_\_\_\_\_

Structural practices for this project site that shall control the runoff from this site shall be silt fence with haybales. This project site will not have a dedicated detention area. Rock Check Dams and Curb Inlet Sediment Barriers shall be used for Erosion Control Measures. A sod swale shall control the velocity dissipation for this project.

At any point where construction vehicles are entering or leaving the site a temporary gravel construction entrance shall be constructed and maintained throughout the course of construction. The entrance shall be wide enough to accommodate all vehicles that will use this entrance and long enough to adequately remove sediment from construction vehicles tires so that it will not be tracked onto public roads. Any off-site tracking from construction vehicles is to be removed and disposed of properly. The entrance shall be constructed with filter fabric over the sub grade followed by 12 inches of B-stone. C-Ballast can be used over the top of the B-stone to level the driving surface, but the larger stone is preferred due to its sediment removal ability.

If any portable sanitary facilities are used on this project, contractor shall ensure and demonstrate compliance with applicable State or local waste disposal, temporary and permanent sanitary sewer or septic system regulations.

No liquid concrete waste shall be discharged to waters of the State. Appropriated controls to prevent the discharge of concrete washout waters must be implemented if concrete washout will occur on-site. A concrete washout area is in approximate area as shown on Erosion Control Plan.

No contaminants from fuel storage areas, hazardous waste storage and truck wash areas shall be discharged to waters of the State. Methods for protecting these areas shall be identified and implemented. These areas should not be located near a water body, if there is a water body on or near the project.



### **Allowable Non-Storm Water Discharges**

The following is a list of some allowable non-storm water discharges that are common to construction sites:

- Irrigation water used for seeding and planting
- Pavement wash waters or waters used for dust control (No detergents or chemicals are permitted)
- Uncontaminated ground water from dewatering of excavated areas
- New construction exterior building wash down discharges
- Fire-fighting activities
- Fire Hydrant flushing

As with storm water discharges the contractor shall take the necessary precautions to prevent the above activities from discharging sediment into receiving waters. Where practical the contractor shall attempt to route non-storm water discharges to the natural drainage paths planned for storm water so that no additional erosion and sediment controls will be necessary. In the event that the non-storm water discharge can not be routed to the storm water drainage paths, the contractor shall implement the additional controls necessary to prevent excessive erosion.

### **Post-Construction Storm Water Management Controls**

Storm water management controls are constructed to prevent or control pollution of storm water after the construction is complete. Post construction controls for this site will be seed or sod on the lots.

### **State & Local Standards**

Contractor must comply with the lawful requirements of municipalities, counties, drainage districts, and other local agencies regarding any discharges of stormwater to storm drain systems or other water sources under their jurisdiction, including applicable requirements in municipal stormwater management programs developed to comply with the ADEQ permits, *Authorization to Discharge under the National Pollutant Discharge Elimination System and the Arkansas Water and Air Pollution Control Act*. Contractor

must comply with local, County, City of Bryant, stormwater management requirements, policies, or guidelines including erosion and sediment control. It is also the contractors' responsibility to determine if any other Federal requirements apply and address them accordingly (such as a 404 Permit). Contractor shall comply with State or local waste disposal, sanitary sewer (including portable toilets), or septic system regulations. Sanitary sewer shall be serviced by the city of Bryant for this project.

# *Assessment*

## **Measurement of Site Area**

Hillcrest Addition is 4.89 acres which is part of the SE ¼ of Section 17, T-1-S, R-14-W, to the City of Bryant, Saline County, Arkansas. The area included in this Storm Water Pollution Prevention Plan is all 4.89 acres, and the amount of soil to be disturbed is also all 4.89 acres.

## **Measurement of Drainage Areas**

It should be noted that individual watersheds were evaluated for the design of the drainage improvements, as shown on Attachment 'D'. Copies of the detailed drainage design calculations are available in the office of the Engineer.

## **Computed Runoff Coefficient**

For the 'lotted' areas, the following assumptions were made:

For paved areas (drives, roofs, etc.)	C = 0.90
For unpaved areas (grass, landscaping, etc.)	C = 0.28

For most lots, half will be improved (C=0.9), while the remainder should fit into the unpaved category (C=0.28). Using the 'weighted average', we will have a runoff coefficient of 0.5. This conservative figure does take into account the streets to exist in front of said lots. For the purpose of these analyses, a pre-construction runoff coefficient of 0.4 is used.

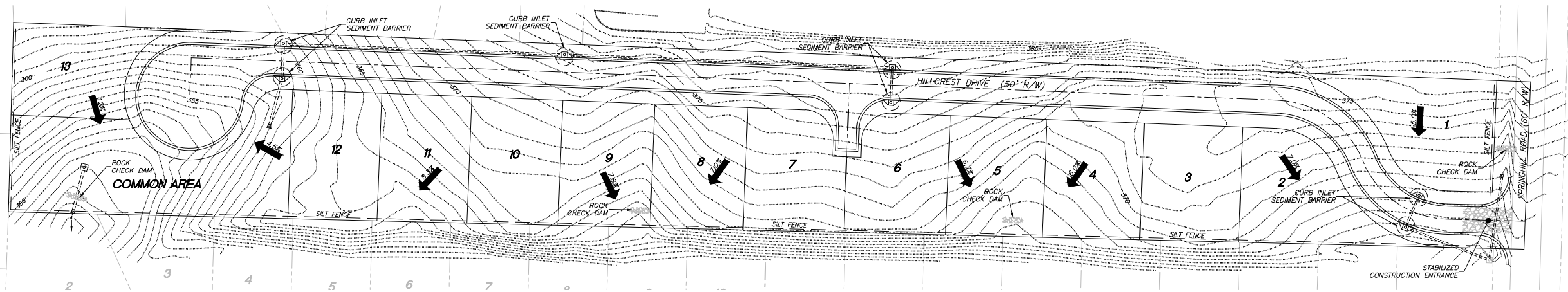

**LEGEND:**  
 - - - - - EXISTING CONTOUR  
 5.0% - - - - - SLOPE & DIRECTION BEFORE GRADING

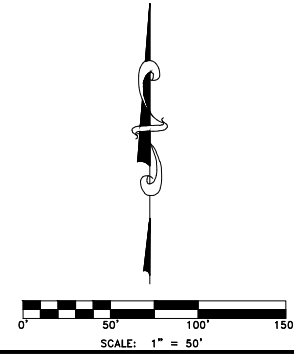

Project No. 24-018	Date JULY 9, 2024	Revisions	Prepared For Springhill HWY 5 Development, LLC 816 E. Oak Street Conway, Arkansas 72032	Attachment D	ATTACHMENT D HILLCREST ADDITION PART OF THE SE 1/4 OF SECTION 17, T-1-S, R-14-W CITY OF BRYANT, SALINE COUNTY, ARKANSAS	LEMONS ENGINEERING CONSULTANTS, INC. 201 CHERRY STREET CABOT, ARKANSAS 72023 (501) 843-5081 • Fax (501) 941-0959
Sheet 1 of 1	Scale 1" = 50'	Drawn By B. Judd			ENGINEERING + SURVEYING WATER • SEWER • TRANSPORTATION • SUBDIVISIONS	

## *Inspection & Maintenance Plan*

This section provides an overview of the inspection and maintenance plan and controls as pertaining to the Stormwater Pollution Prevention Plan. This inspection procedure should be conducted by qualified personnel, (which the permittee provides along with any necessary training, see next sheet) and is necessary in the prevention and control of pollution of storm water on the construction site. Items included in this Plan include the inspection and maintenance of vegetation, erosion and sediment control, and related measures, which are part of this plan. Attention is called to Pages B-1 through B-25 (of the previous section) for information pertaining to maintenance of each anticipated control component. This information, in part, is derived from the “Storm Water Management for Construction Activities” as developed by EPA.

The following list includes the practices that will be used to maintain erosion and sediment controls for this Plan:

- All control measures will be inspected every week and within 24 hours following any storm event of 0.25 inches rainfall or greater rainfall event as measured in the rain gauge located on-site;
- All measures will be inspected to ensure that they meet the proper specs. Repairs to control measures shall be initiated within 72 hours of the report where possible. Additional time may be needed depending on the location of the repair and field conditions. On-site inspector shall determine if extra time is required;
- Inspections are not required when snow cover exists over the entire site for an extended period and melting conditions do not exist. However, if any runoff occurs at any time during snow cover, regular inspections are required as specified in this permit. If conditions prevent compliance, documentation must be made of when the beginning and ending of winter conditions occurred.
- When adverse weather conditions; such as flooding, high winds or electrical storms, make inspections impractical, an inspection is to be made as soon as conditions are safe and feasible. If conditions prevent compliance, documentation must be made of when the beginning and ending of adverse weather conditions occurred.
- Built up sediment will be removed from silt fencing when sediment has reached a height of 1/3 of fence;
- Silt fence shall be inspected for sediment depth, tears, and proper anchoring;
- Sod swales shall be inspected for sediment build-up. Sediment shall be removed as needed;
- Control measures in and around culverts, inlets, and other permanent structures shall be kept clean of debris and sediment;
- Seeding and planting shall be inspected for bare spots, washouts, and adequate growth;
- A maintenance inspection report will be made after each inspection. Blank inspection report form(s) are included in this Plan;
- Sediment barriers and sediment traps will be cleaned out when they reach 50% of the original capacity. (where applicable)

- Construction entrance/exit shall be inspected to ensure no off-site tracking is occurring.
- Inspection Reports are to be kept for a minimum of 3 years after NOT is issued.
- Any off-site sediment is to be removed ASAP. Consent from adjoining owners is to be obtained prior to removal.

**Responsible Parties**

The owner of this project shall be responsible for the inspection and maintenance of all erosion control measures. As structures are constructed on lots, the lot owner/home builder shall be responsible for the lot they are constructing a home on.

**Employee Training**

The permittee shall also be responsible for the proper training of all personnel who will be responsible for implementing the activities identified in this SWPPP, the goals and requirements of the general permit. This shall include all contractors and subcontractors. Training must be given by a knowledgeable and qualified trainer. Records of training must be maintained below. Records that are kept electronically, are not required to be maintained with the SWPPP, but must be accessible upon request. Training class given by a third-party is recommended, but not required. The permittee is responsible for the content of the training being adequate for personnel to implement the requirements of this permit.

Training classes:      Date: \_\_\_\_\_  
    Location: \_\_\_\_\_  
    Time: \_\_\_\_\_

   Date: \_\_\_\_\_  
    Location: \_\_\_\_\_  
    Time: \_\_\_\_\_

   Date: \_\_\_\_\_  
    Location: \_\_\_\_\_  
    Time: \_\_\_\_\_

**ARR150000 Inspection Form**

Appendix B

Inspector Name: \_\_\_\_\_

Date of Inspection: \_\_\_\_\_

Inspector Title: \_\_\_\_\_

Date of Rainfall: \_\_\_\_\_

Duration of Rainfall: \_\_\_\_\_

Days Since Last Rain Event: \_\_\_\_\_ days

Rainfall Since Last Rain Event: \_\_\_\_\_ inches

Description of any Discharges During Inspection: \_\_\_\_\_

Location of Discharges of Sediment/Other Pollutant (specify pollutant & location): \_\_\_\_\_

Locations in Need of Additional BMPs: \_\_\_\_\_

**Information on Location of Construction Activities**

Location	Activity Begin Date	Activity Occuring Now (y/n)?	Activity Ceased Date	Stabilization Initiated Date	Stabilization Complete Date

**Information on BMPs in Need of Maintenance**

Location	In Working Order?	Maintenance Scheduled Date	Maintenance Completed Date	Maintenance to be Performed By

Changes required to the SWPPP: \_\_\_\_\_

Reasons for changes: \_\_\_\_\_

\_\_\_\_\_

\_\_\_\_\_

SWPPP changes completed (date): \_\_\_\_\_

"I certify under penalty of law that this document and all attachments such as Inspection Form were prepared under my direction or supervision in accordance with a system designed to ensure that qualified personnel properly gather and evaluate the information submitted. Based on my inquiry of the person or persons who manage the system, or those persons directly responsible for gathering the information, the information submitted is, to the best of my knowledge and belief, true, accurate, and complete. I am aware that there are significant penalties for submitting false information, including the possibility of fine and imprisonment for knowing violations."

Signature of Responsible or Cognizant Official: \_\_\_\_\_ Date: \_\_\_\_\_

Title: \_\_\_\_\_

**SEE VOLUME #3**

**FOR**

**INSPECTION**

**REPORTS**



***INSPECTORS CERTIFICATION***

I certify under penalty of law that I understand the terms and conditions set forth by the permittee (operator) under the Stormwater Pollution Prevention Plan associated with the construction site identified as part of this certification. I shall make major observations relating to the implementation of the stormwater pollution prevention plan and take actions in accordance with the requirements of this permit and retain as part of this plan for at least three (3) years from the date that this site is finally stabilized. I am aware that there are significant penalties for submitting false information, including the possibility of fine and imprisonment for knowing violations.

7-9-2024

\_\_\_\_\_  
Signature

\_\_\_\_\_  
Date

Lance Massey, Developer/Construction Manager

\_\_\_\_\_  
Printed Name & Title

501-428-3866

\_\_\_\_\_  
Phone Number

**\*Inspectors certification must be signed by inspector prior to any construction of work beginning.**

***CONTRACTORS CERTIFICATION***

I certify under penalty of law that I understand the terms and conditions set forth by the permittee (operator) under the Stormwater Pollution Prevention Plan associated with the construction site identified as part of this certification. Furthermore, I understand that the ADEQ and/or the operator may require me to obtain my own permit coverage for the construction site and that there would be penalties for failure to comply with my permit.

7-9-2024

\_\_\_\_\_  
Signature

\_\_\_\_\_  
Date

Lance Massey, Developer/Construction Manager  
\_\_\_\_\_  
Printed Name & Title

Springhill Hwy 5 Developments LLC  
\_\_\_\_\_  
Name of Contracting Firm  
816 East Oak Street, Conway, AR 72032

\_\_\_\_\_  
Address  
501-428-3866

\_\_\_\_\_  
Phone Number

**\*Contractors certification must be signed by contractor prior to any construction of work beginning.**

***PLAN CERTIFICATION***

I certify under penalty of law that this document and all attachments were prepared under my direction or supervision in accordance with a system designed to assure that qualified personnel properly gather and evaluate the information submitted. Based on my inquiry of the person or persons who manage the system, or those persons directly responsible for gathering the information, the information submitted is, to the best of my knowledge and belief, true, accurate, and complete. I am aware that there are significant penalties for submitting false information, including the possibility of fine and imprisonment for knowing violations.

\_\_\_\_\_  
Signature

Lance Massey, Developer/Construction Manager  
Printed Name & Title

7-9-2024

\_\_\_\_\_  
Date



Signature

Tim Lemons - Engineer  
Printed Name & Title

Lemons Engineering Consultants, Inc.  
Name of Contracting Firm

204 Cherry Street, Cabot, AR 72023  
Address

501-605-7565  
Phone Number

7-9-2024

\_\_\_\_\_  
Date

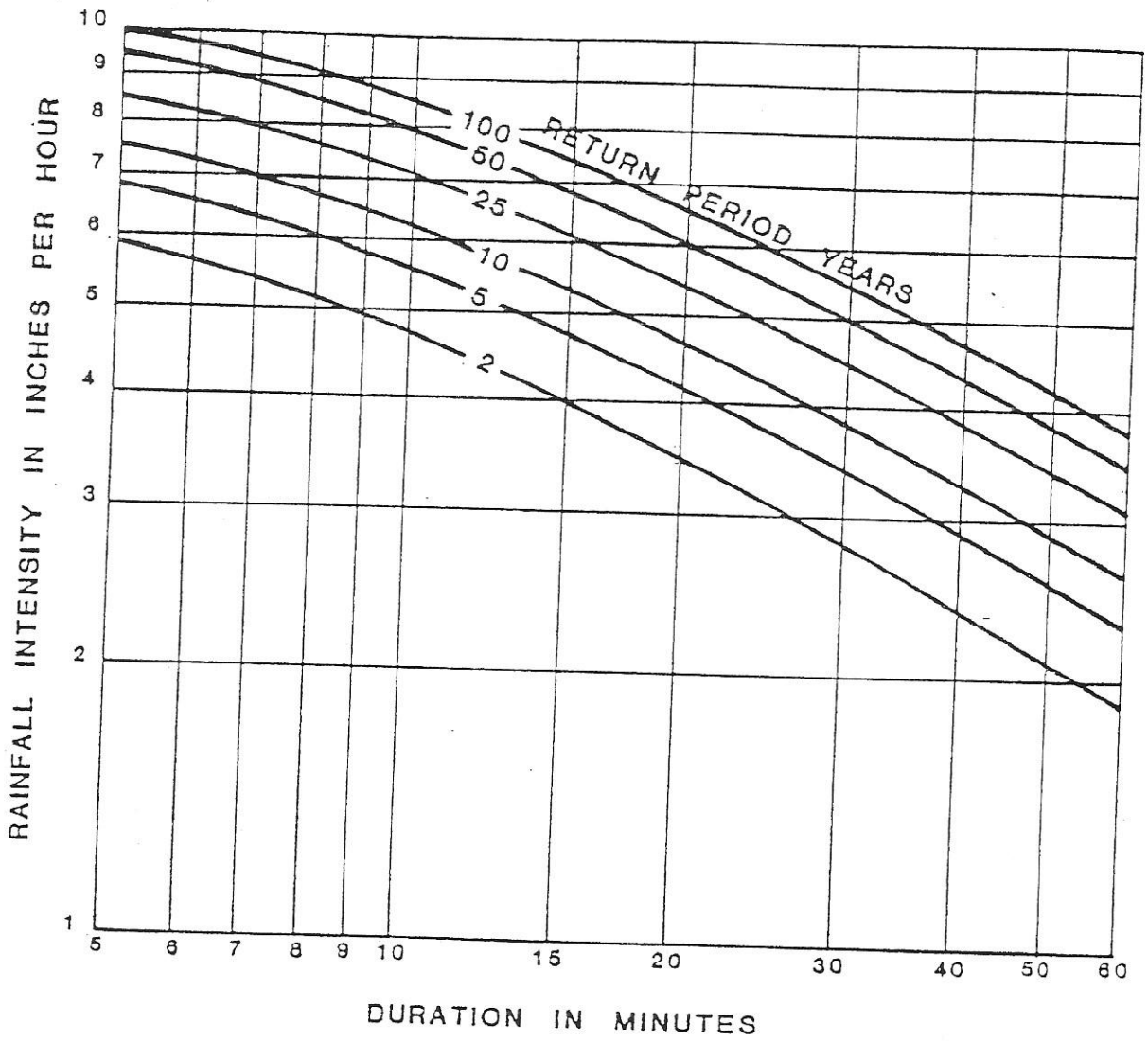

INTENSITY - DURATION - FREQUENCY

LITTLE ROCK

SOURCE: HYDRO 35 & T.P. No. 40

TABLE 2.1 RUNOFF COEFFICIENTS FOR RATIONAL METHOD

LAND USE TYPES	RUNOFF COEFFICIENTS		
	FREQUENCY		
	10	25	100
<u>Business:</u>			
Central Business District	.90	.93	.95
Commercial Area	.85(.70-.95)*	.90	.95
Neighborhood Area	.70(.50-.75)	.75	.80
<u>Residential:</u>			
Single Family	.50(.30-.60)	.60	.70
Multi-Unit (Detached)	.60(.40-.65)	.65	.75
Multi-Unit (Attached)	.70(.60-.75)	.75	.80
1/2 AC Lots or Larger	.40(.25-.50)	.45	.65
Apartments	.70(.50-.80)	.75	.80
<u>Industrial:</u>			
Light Areas	.80(.50-.85)	.82	.85
Heavy Areas	.85(.60-.90)	.87	.90
<u>Parks and Cemeteries</u>	.30(.10-.40)	.40	.60
<u>Playgrounds</u>	.35(.20-.40)	.50	.70
<u>Schools and Churches</u>	.60(.50-.75)	.65	.75
<u>Railroad Yards</u>	.50(.30-.60)	.60	.70
<u>Offsite Flow Analysis (When Land Use Not Defined)</u>	.55(.45-.65)	.67	.70

\*NOTE: The range of runoff coefficients based on soil type: The low value is for sandy soils, while the high value is for clay soils. The given runoff coefficient outside the parenthesis is to be used for design, unless the Engineer of Record receives approval from the City Engineer for another value located within the given coefficient range.

TABLE 2.2 RUNOFF COEFFICIENTS FOR RATIONAL METHOD COMPOSITE ANALYSIS

CHARACTER OF SURFACE	RUNOFF COEFFICIENTS		
	FREQUENCY		
	10	25	100
<u>Undeveloped Areas:</u>			
Historic Flow Analysis, Greenbelts, Agricultural, Natural Vegetation			
Clay Soil			
Flat, 2%	.30	.33	.37
Average, 2-7%	.40	.44	.50
Steep 7%	.50	.55	.62
Sandy Soil			
Flat, 2%	.12	.13	.15
Average, 2-7%	.20	.22	.25
Steep 7%	.30	.33	.37
<u>Streets:</u>			
Paved	.90	.92	.95
Gravel	.35	.50	.65
<u>Drives and Walks:</u>	.90	.91	.92
<u>Roofs:</u>	.90	.92	.95
<u>Lawns:</u>			
Clay Soil			
Flat, 2%	.18	.20	.25
Average, 2-7%	.22	.28	.35
Steep, 7%	.35	.45	.60
Sandy Soil			
Flat, 2%	.10	.25	.40
Average, 2-7%	.15	.30	.45
Steep, 7%	.20	.35	.50

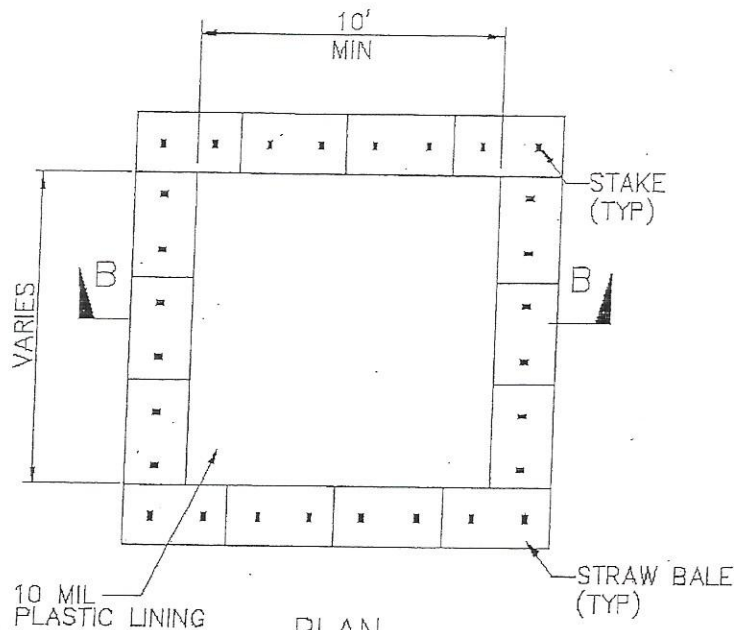

PLAN  
NOT TO SCALE  
TYPE "ABOVE GRADE"  
WITH STRAW BALES

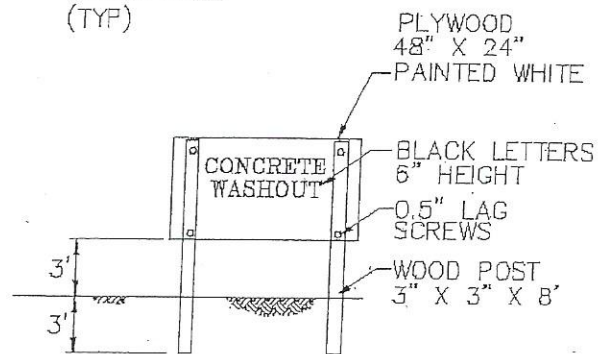
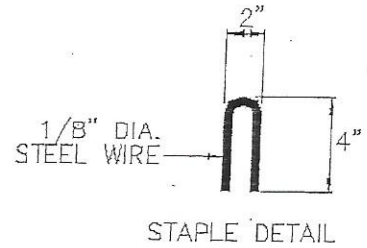

CONCRETE WASHOUT  
SIGN DETAIL  
(OR EQUIVALENT)

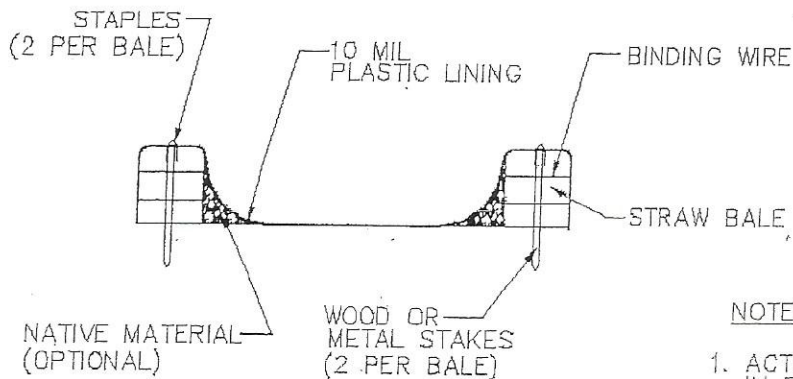

SECTION B-B  
NOT TO SCALE

NOTES

1. ACTUAL LAYOUT DETERMINED IN FIELD.
2. THE CONCRETE WASHOUT SIGN SHALL BE INSTALLED WITHIN 30 FT. OF THE TEMPORARY CONCRETE WASHOUT FACILITY.



## Onsite Temporary Concrete Washout Facility

- Temporary concrete washout facilities should be located a minimum of 50 ft from storm drain inlets, open drainage facilities, and watercourses. Each facility should be located away from construction traffic of access areas to prevent disturbance or tracking.
- A sign should be installed adjacent to each washout facility to inform concrete equipment operators to utilize the proper facilities.
- Temporary concrete washout facilities should be constructed above grade. Facility should be constructed and maintained in sufficient quantity and size to contain all liquids generated during washout procedures.
- Temporary washout facilities should have a temporary pit or bermed areas of sufficient volume to completely contain all liquid and waste concrete materials generated during washout procedures.
- Washout of concrete trucks should be performed in designated areas only.
- Only concrete from mixer truck chutes should be washed into concrete washout.
- Concrete washout from concrete pumper bins can be washed into concrete pumper trucks and discharged into designed washout areas or properly disposed of offsite.
- Once concrete wastes are washed into the designated areas and slowed to harden, the concrete should be broken up, removed and disposed of. Dispose of hardened concrete on a regular basis.
- Temporary concrete washout facility should be constructed according to the detail, with a recommended minimum length and minimum width of 10 ft, but with sufficient quantity and volume to contain all liquid and concrete waste generated by washout operations.
- Plastic lining material should be a minimum of 10 mil in polyethylene sheeting and should be free of holes, tears, or other defects that compromise the impermeability of the material.



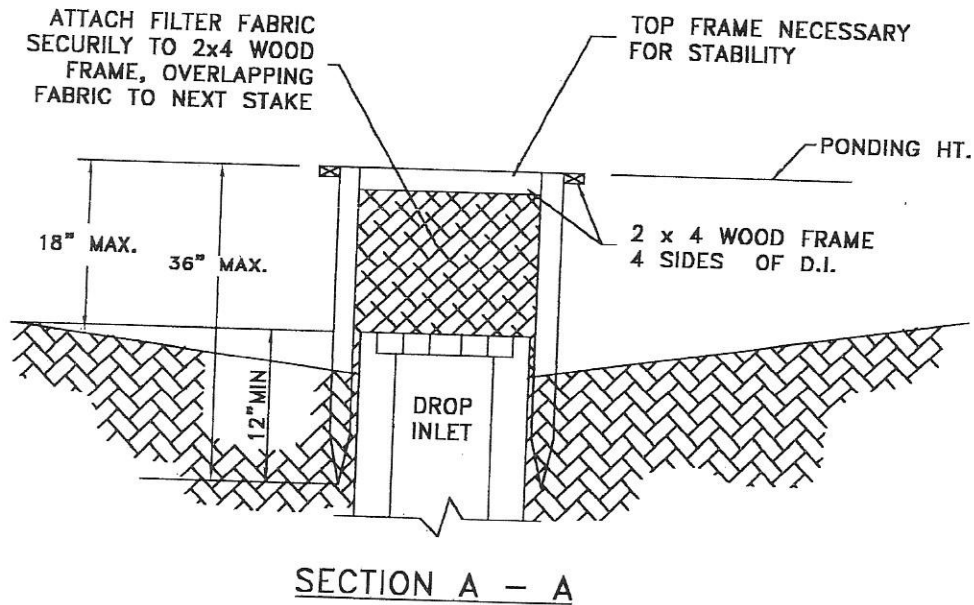
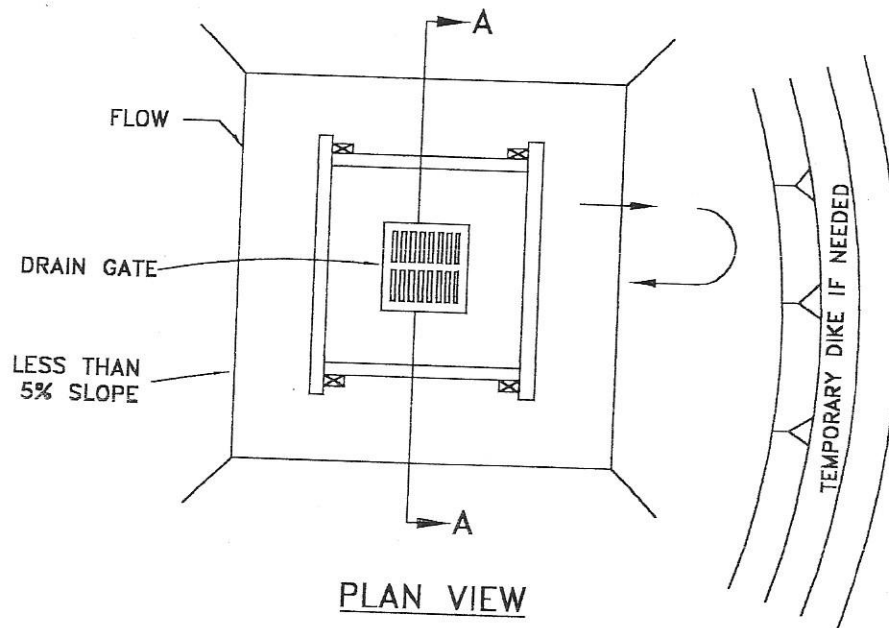

NOTES:

- 1.) DROP INLET SEDIMENT BARRIERS ARE TO BE USED FOR SMALL NEARLY LEVEL DRAINAGE AREAS.
- 2.) USE 2 x 4 WOOD OR EQUIVALENT METAL STAKES, (3 FT. MIN. LENGTH).
- 3.) INSTALL 2 x 4 WOOD TOP FRAME TO INSURE STABILITY.
- 4.) THE TOP OF THE FRAME (PONDING HEIGHT) MUST BE WELL BELOW THE GROUND ELEVATION DOWNSLOPE TO PREVENT RUNOFF FROM BY-PASSING THE INLET. A TEMPORARY DIKE MAY BE NECESSARY ON THE DOWNSLOPE SIDE OF THE STRUCTURE.

SILT FENCE  
DROP INLET  
SEDIMENT BARRIER

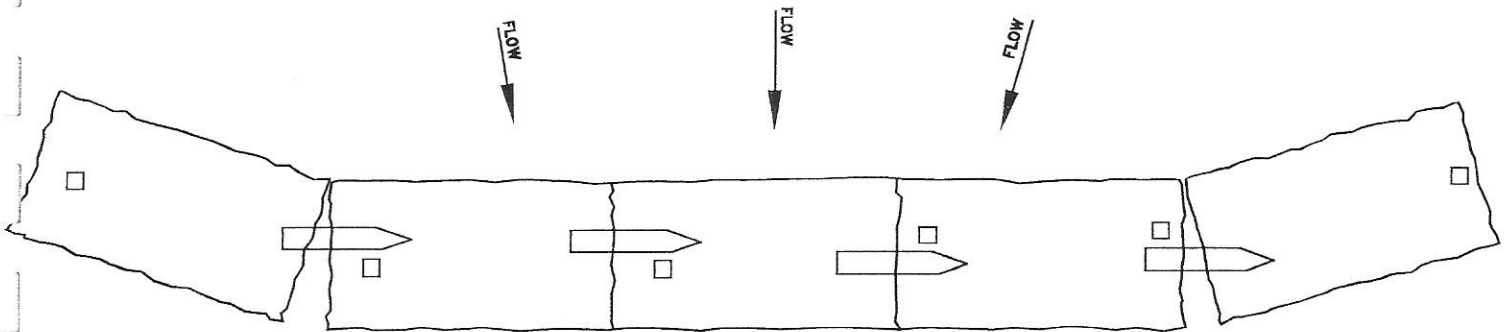
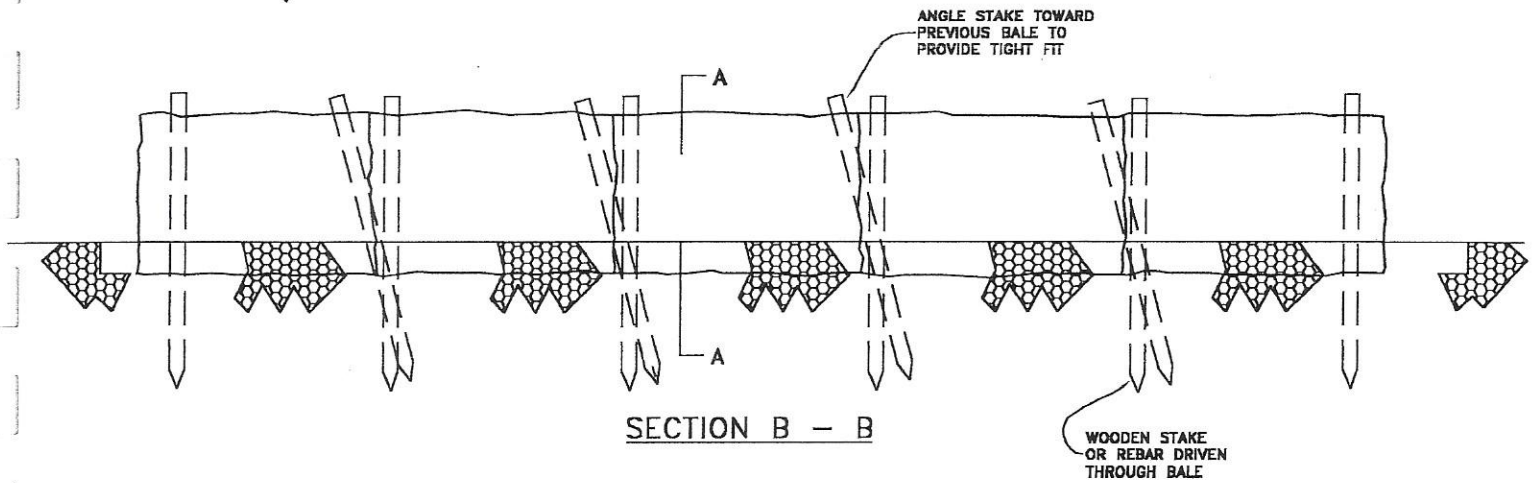
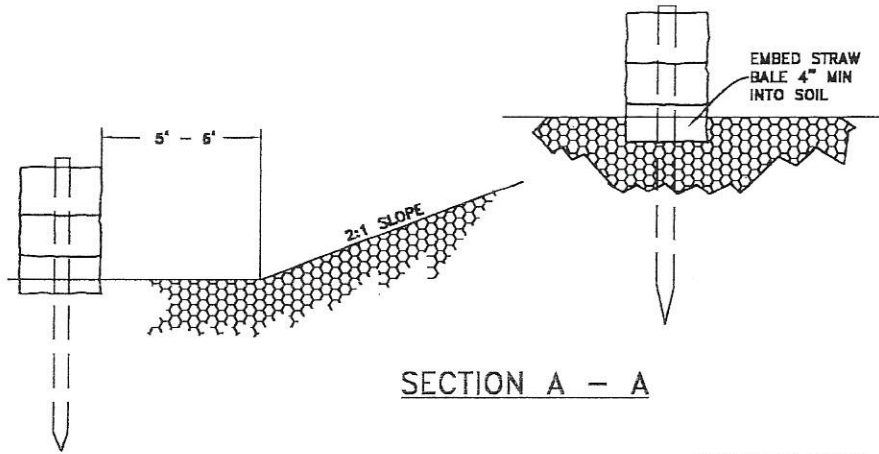

PLAN

NOTES:

- 1.) THE STRAW BALES SHALL BE PLACED ON THE SLOPE CONTOUR.
- 2.) BALES TO BE PLACED IN A ROW WITH THE ENDS TIGHTLY ABUTTING. USE STRAW, ROCKS, OR FILTER FABRIC TO FILL THE GAPS BETWEEN THE BALES AND TAMP THE BACKFILL MATERIAL TO PREVENT EROSION OR BACK FLOW AROUND BALES.

STRAW BALE  
DIKE

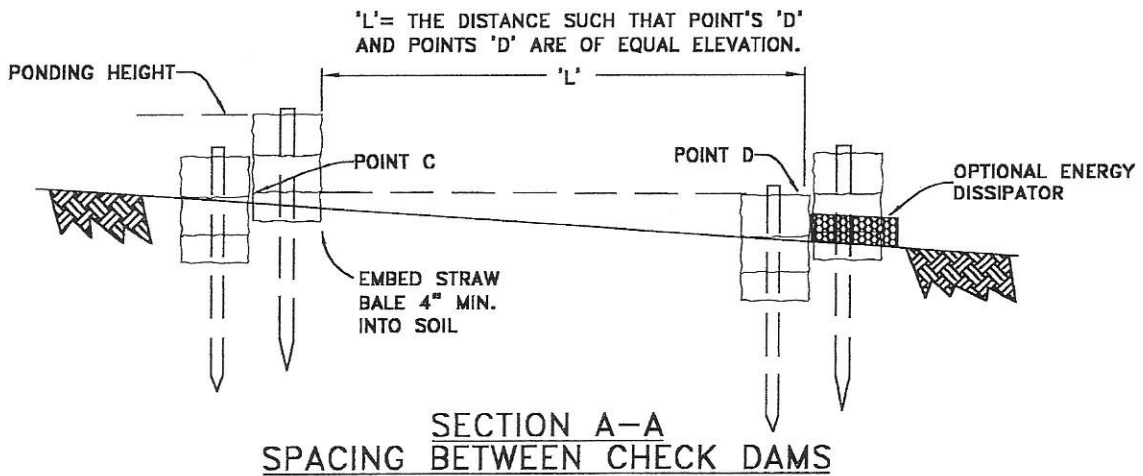
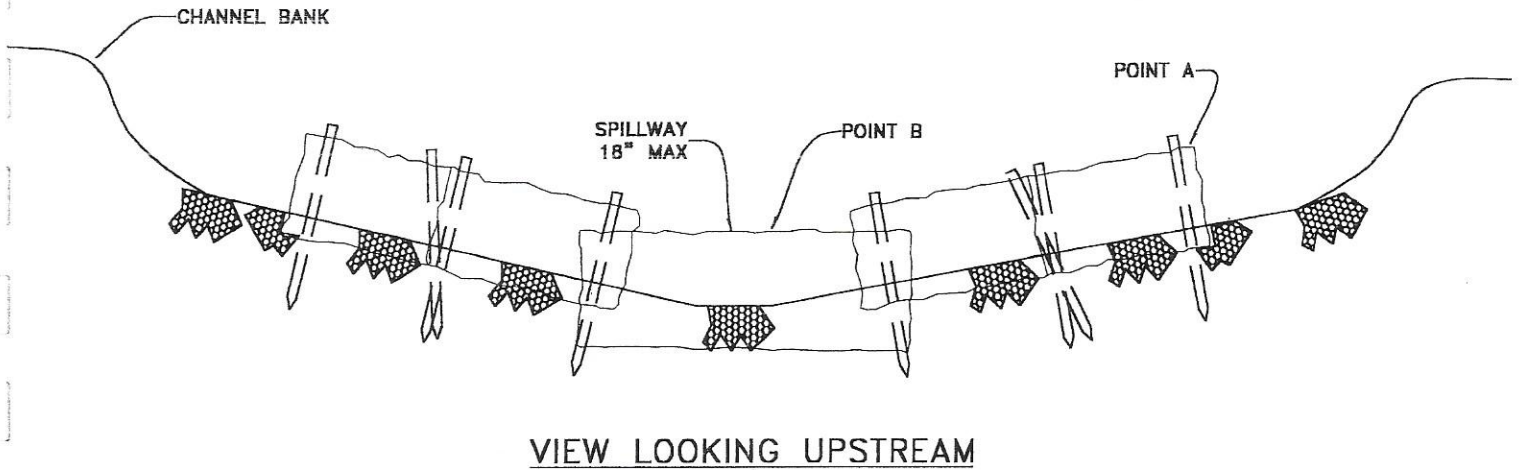
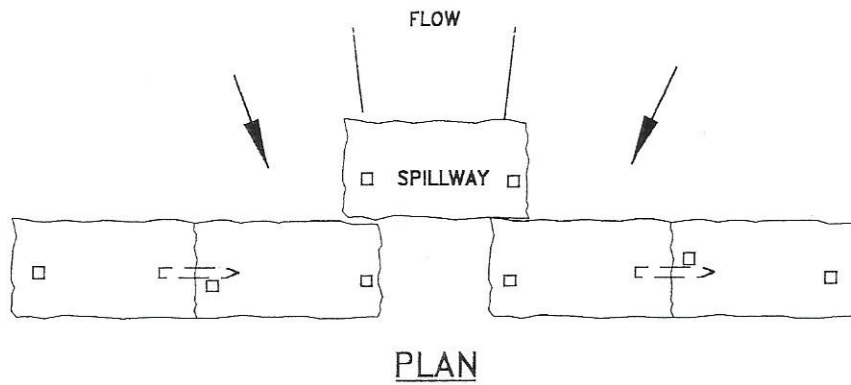

**NOTES:**

- 1.) EMBED BALES 4" INTO THE SOIL AND 'KEY' BALES INTO THE CHANNEL BANKS.
- 2.) POINT 'A' MUST BE HIGHER THAN POINT 'B' (SPILLWAY HEIGHT)
- 3.) PLACE BALES PERPENDICULAR TO THE FLOW WITH ENDS TIGHTLY ABUTTING. USE STRAW, ROCKS OR FILTER FABRIC TO FILL ANY GAPS AND TAMP BACKFILL MATERIAL TO PREVENT EROSION OR FLOW AROUND THE BALES.
- 4.) SPILLWAY HEIGHT SHALL NOT EXCEED 18".
- 5.) INSPECT AFTER EACH SIGNIFICANT STORM, MAINTAIN AND REPAIR PROMPTLY.
- 6.) SPACING OF CHECK DAMS ARE AS SHOWN.

STRAW BALE  
CHECK DAM

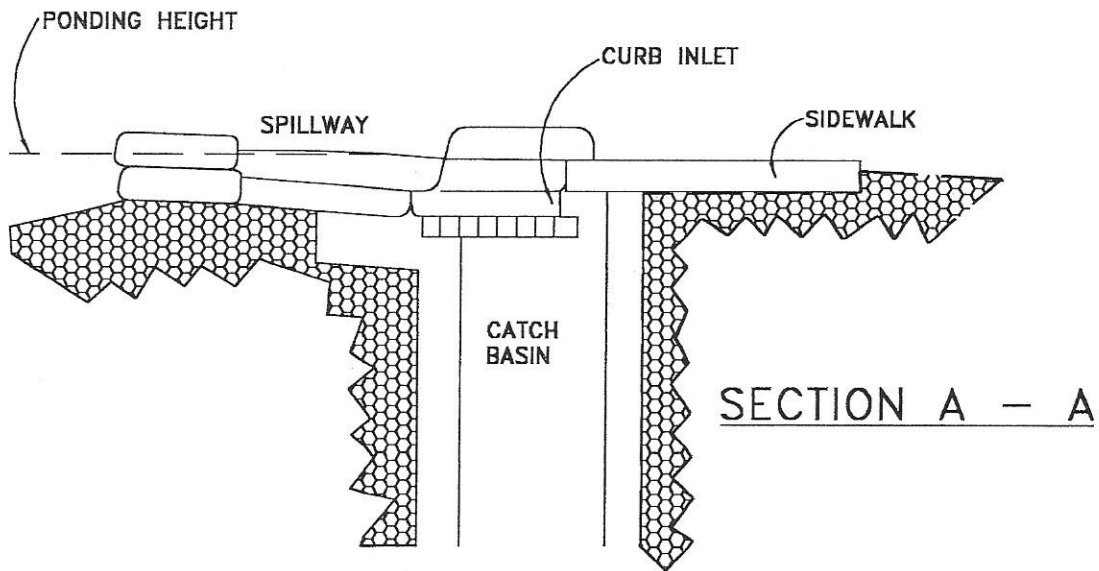
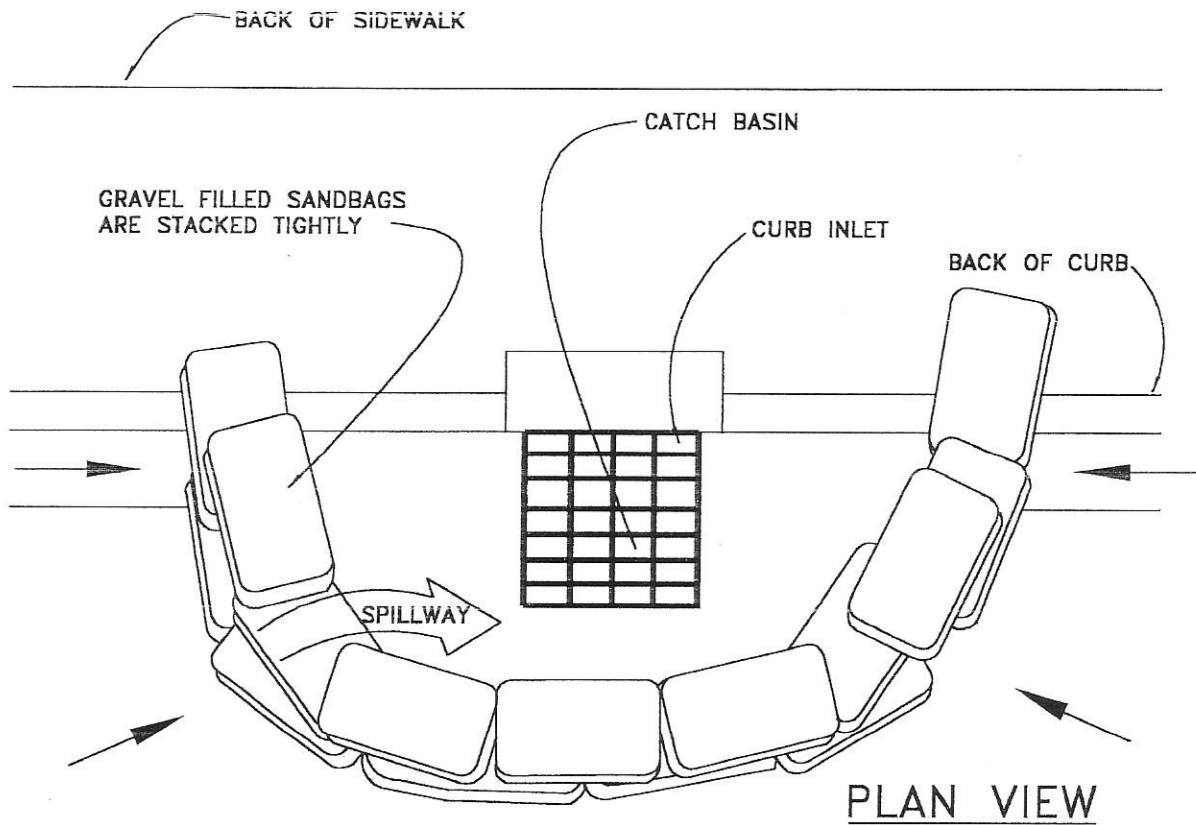

**NOTES:**

- 1.) PLACE CURB TYPE SEDIMENT BARRIERS ON GENTLY SLOPING STREET SEGMENTS WHERE WATER CAN POND AND ALLOW SEDIMENT TO SEPARATE FROM RUNOFF.
- 2.) SANDBAGS OF EITHER BURLAP OR WOVEN GEOTEXTILE FABRIC ARE FILLED WITH GRAVEL, LAYERED, AND PACKED TIGHTLY.
- 3.) LEAVE ONE SANDBAG GAP IN THE TOP ROW TO PROVIDE A SPILLWAY FOR OVERFLOW.
- 4.) INSPECT BARRIERS AND REMOVE SEDIMENT AFTER EACH STORM EVENT. SEDIMENT AND GRAVEL MUST BE REMOVED FROM THE TRAVELED WAY IMMEDIATELY.

## CURB INLET SEDIMENT BARRIER



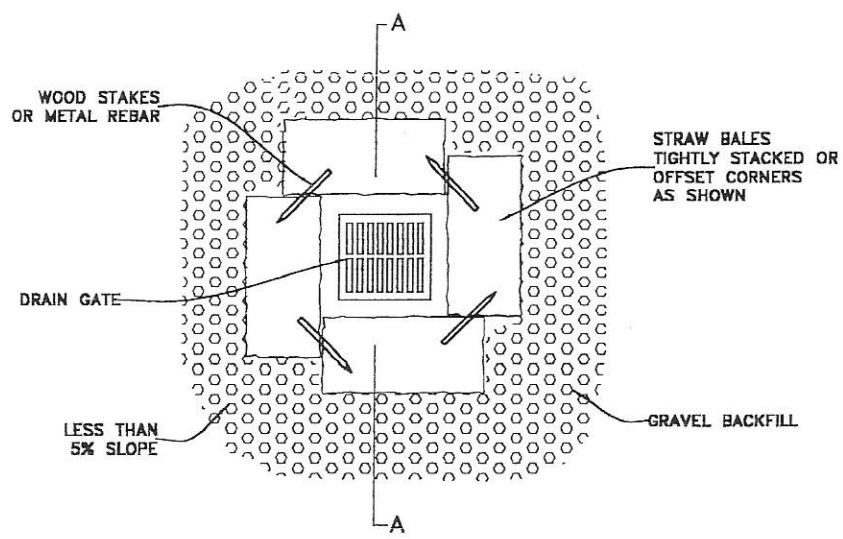

PLAN VIEW

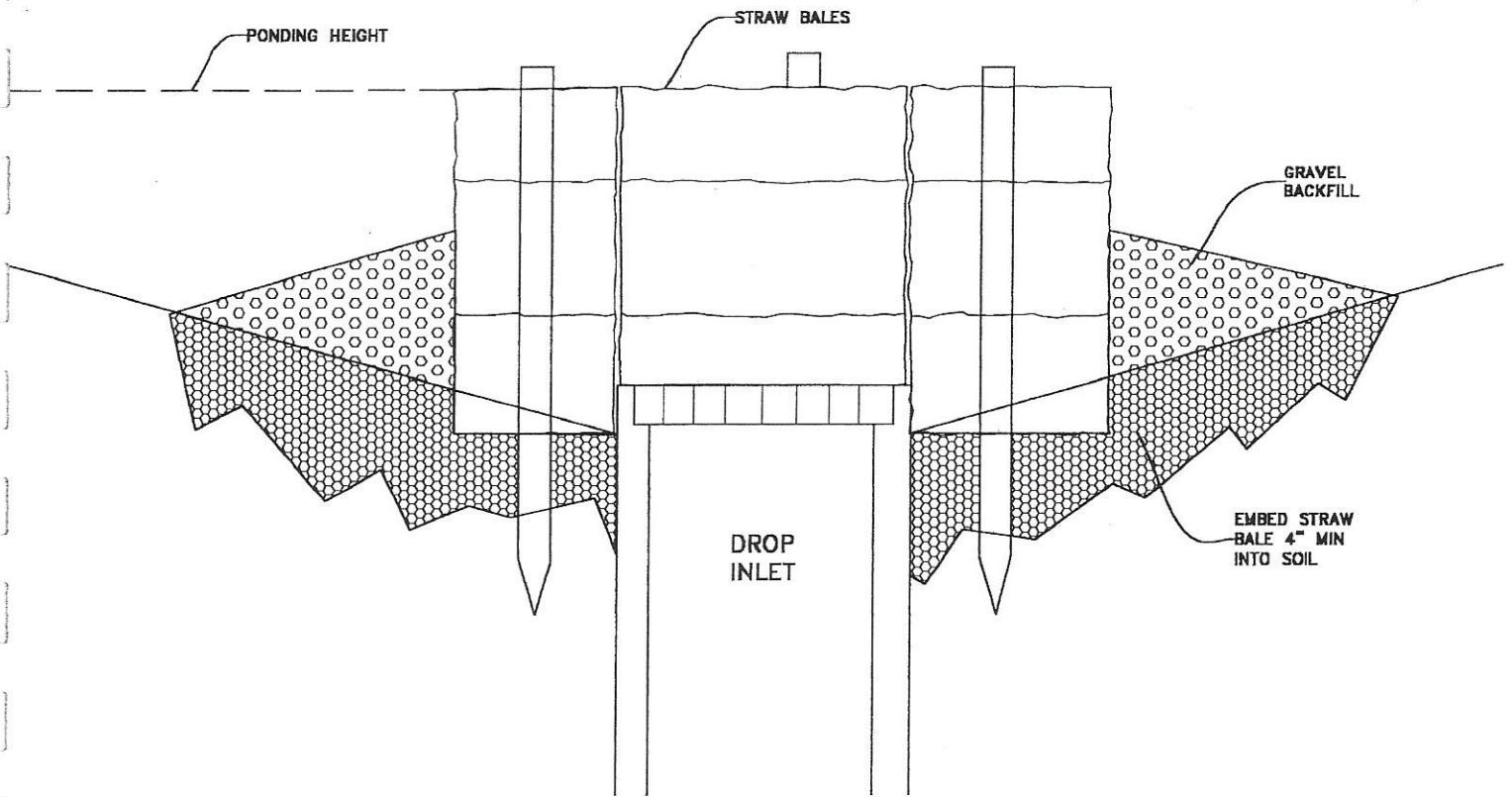

SECTION A-A

NOTES:

- 1.) DROP INLET SEDIMENT BARRIERS ARE TO BE USED FOR SMALL NEARLY LEVEL DRAINAGE AREAS.
- 2.) EMBED THE BALES 4" INTO THE SOIL AND OFFSET THE CORNERS OR PLACE BALES WITH ENDS TIGHTLY ABUTING. GRAVEL BACKFILL WILL PREVENT EROSION OR FLOW AROUND THE BALES.
- 3.) THE TOP OF THE STRUCTURE (PONDING HEIGHT) MUST BE WELL BELOW THE GROUND ELEVATION DOWNSLOPE TO PREVENT RUNOFF FROM BY-PASSING THE INLET. EXCAVATION OF A BASIN ADJACENT TO THE DROP INLET OR A TEMPORARY DIKE ON THE DOWNSLOPE OF THE STRUCTURE MAY BE NECESSARY.

STRAW BALE/GRAVEL  
DROP INLET  
SEDIMENT BARRIER

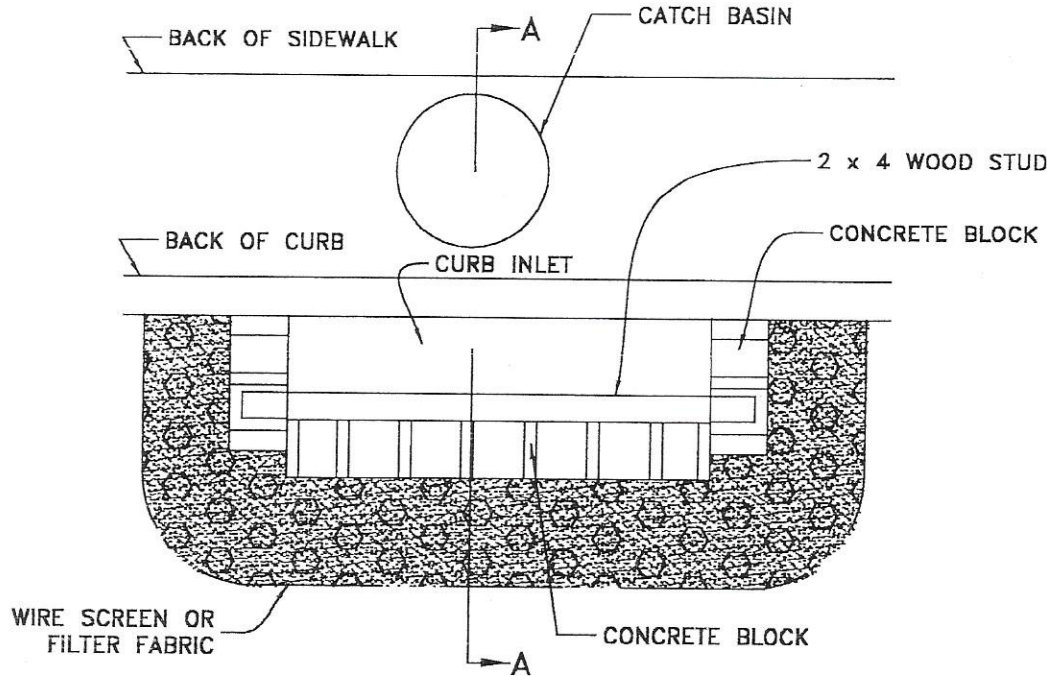

PLAN VIEW

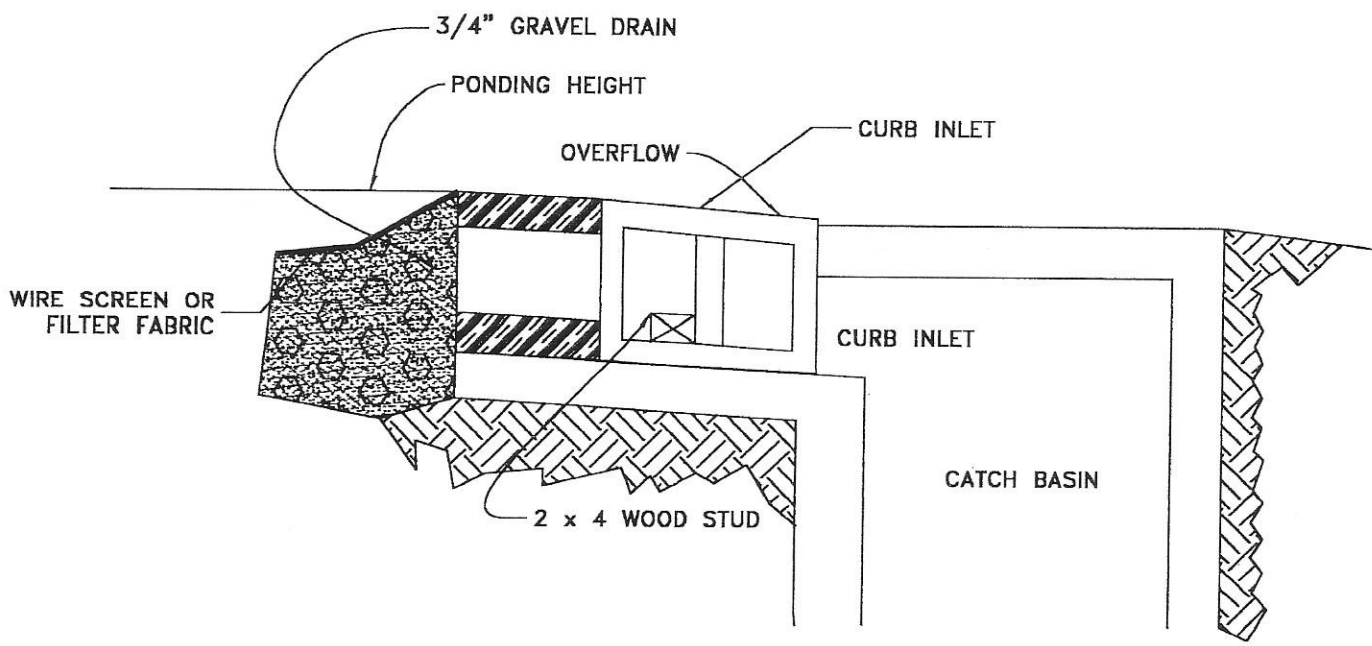

SECTION A - A

NOTES:

- 1.) USE BLOCK AND GRAVEL TYPE SEDIMENT BARRIER WHEN CURB INLET IS LOCATED IN GENTLY SLOPING STREET SEGMENT, WHERE WATER CAN POND AND ALLOW SEDIMENT TO SEPARATE FROM RUNOFF.
- 2.) BARRIER SHALL ALLOW FOR OVERFLOW FROM SEVERE STORM EVENT.
- 3.) INSPECT BARRIERS AND REMOVE SEDIMENT AFTER EACH STORM EVENT. SEDIMENT AND GRAVEL MUST BE REMOVED FROM THE TRAVELED WAY IMMEDIATELY.

CURB INLET  
SEDIMENT BARRIER

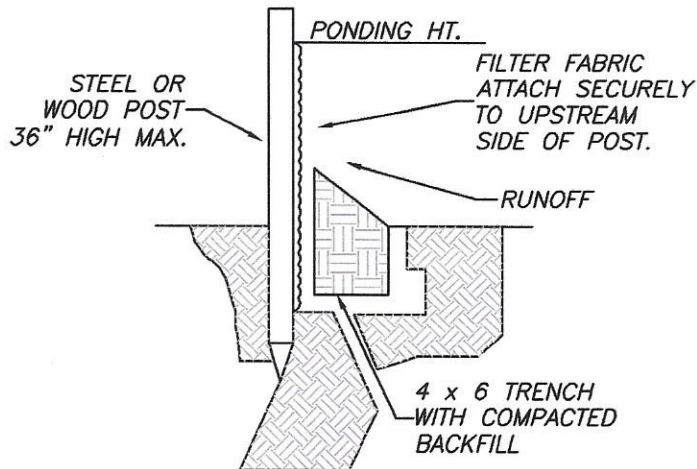
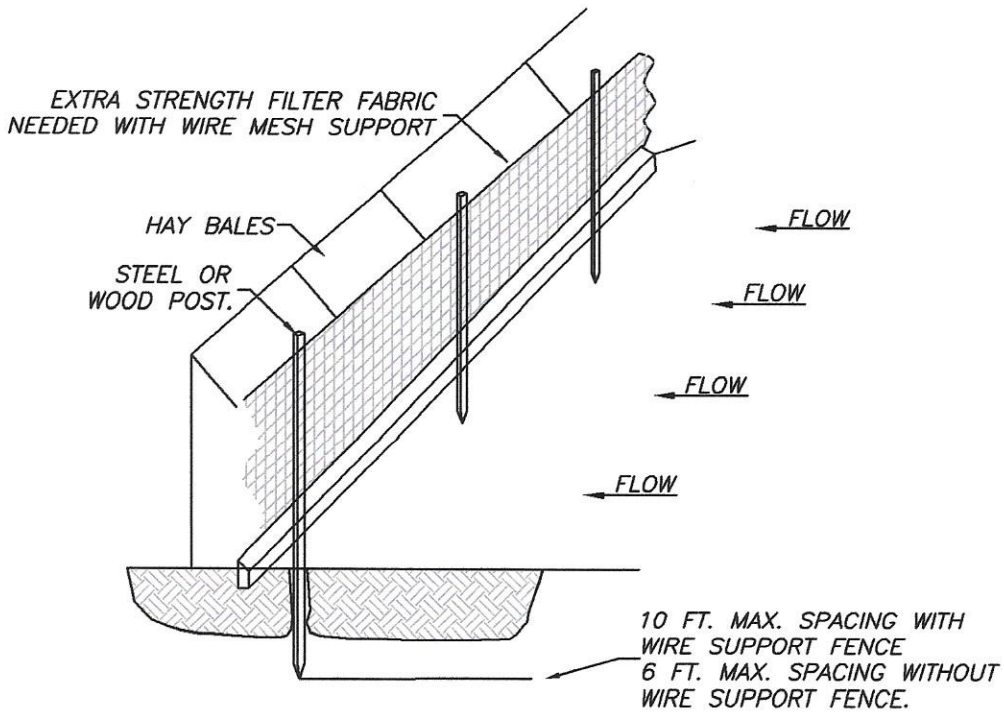

**STANDARD DETAIL**  
**TRENCH WITH NATIVE GRAVEL**

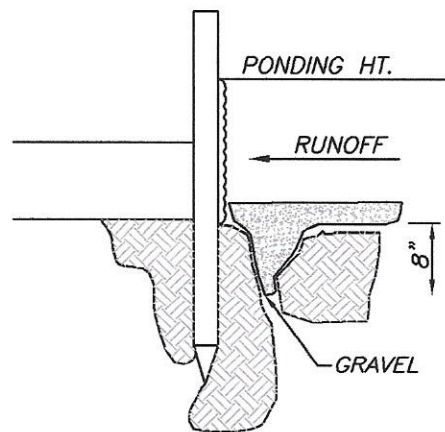

**ALTERNATE DETAIL**  
**TRENCH WITH GRAVEL**

**NOTE:**

- 1.) INSPECT AND REPAIR FENCE AFTER EACH STORM EVENT AND REMOVE SEDIMENT WHEN NECESSARY.
- 2.) REMOVED SEDIMENT SHALL BE DEPOSITED TO AN AREA THAT WILL NOT CONTRIBUTE SEDIMENT OFF-SITE AND CAN BE PERMANENTLY STABILIZED.
- 3.) SILT FENCE SHALL BE PLACED ON SLOPE CONTOURS TO MAXIMIZE PONDING EFFICIENCY.

**SILT FENCE**  
**NTS**



## SILT FENCE

September 1992

### Design Criteria

- ▲ Silt fences are appropriate at the following general locations:
  - ▲ Immediately upstream of the point(s) of runoff discharge from a site before flow becomes concentrated (maximum design flow rate should not exceed 0.5 cubic feet per second).
  - ▲ Below disturbed areas where runoff may occur in the form of overland flow.
- ▲ Ponding should not be allowed behind silt fences since they will collapse under high pressure; the design should provide sufficient outlets to prevent overtopping.
- ▲ The drainage area should not exceed 0.25 acre per 100 feet of fence length.
- ▲ For slopes between 50:1 and 5:1, the maximum allowable upstream flow path length to the fence is 100 feet; for slopes of 2:1 and steeper, the maximum is 20 feet.
- ▲ The maximum upslope grade perpendicular to the fence line should not exceed 1:1.
- ▲ Synthetic silt fences should be designed for 6 months of service; burlap is only acceptable for periods of up to 60 days.

### Materials

- ▲ Synthetic filter fabric should be a pervious sheet of polypropylene, nylon, polyester, or polyethylene yarn conforming to the requirements in Table 1 below.

TABLE 1. SYNTHETIC FILTER FABRIC REQUIREMENTS

Physical Property	Requirements
Filtering Efficiency	75% - 85% (minimum)
Tensile Strength at 20% (maximum) Elongation	Standard Strength - 30 lb/linear inch (minimum)
	Extra Strength - 50 lb/linear inch (minimum)
Slurry Flow Rate	0.3 gal/ft <sup>2</sup> /min (minimum)

- ▲ Synthetic filter fabric should contain ultraviolet ray inhibitors and stabilizers to provide a minimum of 6 months of expected usable construction life at a temperature range of 0 to 120°F.
- ▲ Burlap of 10 ounces per square yard of fabric can also be used.
- ▲ The filter fabric should be purchased in a continuous roll to avoid joints.
- ▲ While not required, wire fencing may be used as a backing to reinforce standard strength filter fabric. The wire fence (14 gauge minimum) should be at 22-48 inches wide and should have a maximum mesh spacing of 6 inches.
- ▲ Posts should be 2-4 feet long and should be composed of either 2" x 2-4" pine (or equivalent) or 1.00 to 1.33 lb/linear ft steel. Steel posts should have projections for fastening wire and fabric to them.

### Construction Specifications

- ▲ The maximum height of the filter fence should range between 18 and 36 inches above the ground surface (depending on the amount of upslope ponding expected).



## SILT FENCE

- ▲ Posts should be spaced 8 to 10 feet apart when a wire mesh support fence is used and no more than 6 feet apart when extra strength filter fabric (without a wire fence) is used. The posts should extend 12 to 30 inches into the ground.
- ▲ A trench should be excavated 4 to 8 inches wide and 4 to 12 inches deep along the upslope side of the line of posts.
- ▲ If standard strength filter fabric is to be used, the optional wire mesh support fence may be fastened to the upslope side of the posts using 1 inch heavy duty wire staples, tie wires, or hog rings. Extend the wire mesh support to the bottom of the trench. The filter fabric should then be stapled or wired to the fence, and 8 to 20 inches of the fabric should extend into the trench (Figure 1).
- ▲ Extra strength filter fabric does not require a wire mesh support fence. Staple or wire the filter fabric directly to the posts and extend 8 to 20 inches of the fabric into the trench (Figure 1).
- ▲ Where joints in the fabric are required, the filter cloth should be spliced together only at a support post, with a minimum 6-inch overlap, and securely sealed.
- ▲ Do not attach filter fabric to trees.
- ▲ Backfill the trench with compacted soil or 0.75 inch minimum diameter gravel placed over the filter fabric.

### Maintenance

- ▲ Inspect filter fences daily during periods of prolonged rainfall, immediately after each rainfall event, and weekly during periods of no rainfall. Make any required repairs immediately.
- ▲ Sediment must be removed when it reaches one-third to one-half the height of the filter fence. Take care to avoid damaging the fence during cleanout.
- ▲ Filter fences should not be removed until the upslope area has been permanently stabilized. Any sediment deposits remaining in place after the filter fence has been removed should be dressed to conform with the existing grade, prepared, and seeded.

### Cost

- ▲ Silt fence installation costs approximately \$6.00 per linear foot.

### Sources

- ▲ Commonwealth of Virginia - County of Fairfax, 1987. 1987 Check List For Erosion And Sediment Control - Fairfax County, Virginia.
- ▲ State of North Carolina, 1988. Erosion and Sediment Control Planning and Design Manual. North Carolina Sedimentation Control Commission, Department of Natural Resources and Community Development.
- ▲ Maryland Department of the Environment, 1991. 1991 Maryland Standards And Specifications For Soil Erosion And Sediment Control - Draft.

## PIPE SLOPE DRAIN

September 1992

### Design Criteria

- ▲ Pipe Slope Drains (PSD) are appropriate in the following general locations:
  - ▲ On cut or fill slopes before permanent storm water drainage structures have been installed.
  - ▲ Where earth dikes or other diversion measures have been used to concentrate flows.
  - ▲ On any slope where concentrated runoff crossing the face of the slope may cause gullies, channel erosion, or saturation of slide-prone soils.
  - ▲ As an outlet for a natural drainageway.
- ▲ The drainage area may be up to 10 acres; however, many jurisdictions consider 5 acres the recommended maximum.
- ▲ The PSD design should handle the peak runoff for the 10-year storm. Typical relationships between area and pipe diameter are shown in Table 2 below.

TABLE 2. RELATIONSHIP BETWEEN AREA AND PIPE DIAMETER

Maximum Drainage Area (Acres)	Pipe Diameter (D) (Inches)
0.5	12
0.75	15
1.0	18

### Materials

- ▲ Pipe may be heavy duty flexible tubing designed for this purpose, e.g., nonperforated, corrugated plastic pipe, corrugated metal pipe, bituminous fiber pipe, or specially designed flexible tubing.
- ▲ A standard flared end section secured with a watertight fitting should be used for the inlet. A standard T-section fitting may also be used.
- ▲ Extension collars should be 12-inch long sections of corrugated pipe. All fittings must be watertight.

### Construction Specifications

- ▲ Place the pipe slope drain on undisturbed or well-compacted soil.
- ▲ Soil around and under the entrance section must be hand-tamped in 4-inch to 8-inch lifts to the top of the dike to prevent piping failure around the inlet.
- ▲ Place filter cloth under the inlet and extend 5 feet in front of the inlet and be keyed in 6-inches on all sides to prevent erosion. A 6-inch metal toe plate may also be used for this purpose.
- ▲ Ensure firm contact between the pipe and the soil at all points by backfilling around and under the pipe with stable soil material hand compacted in lifts of 4-inches to 8-inches.
- ▲ Securely stake the PSD to the slope using grommets provided for this purpose at intervals of 10 feet or less.
- ▲ Ensure that all slope drain sections are securely fastened together and have watertight fittings.

## PIPE SLOPE DRAIN

- ▲ Extend the pipe beyond the toe of the slope and discharge at a nonerosive velocity into a stabilized area (e.g., rock outlet protection may be used) or to a sedimentation trap or pond.
- ▲ The PSD should have a minimum slope of 3 percent or steeper.
- ▲ The height at the centerline of the earth dike should range from a minimum of 1.0 foot over the pipe to twice the diameter of the pipe measured from the invert of the pipe. It should also be at least 6 inches higher than the adjoining ridge on either side.
- ▲ At no point along the dike will the elevation of the top of the dike be less than 6 inches higher than the top of the pipe.
- ▲ Immediately stabilize all areas disturbed by installation or removal of the PSD.

### Maintenance

- ▲ Inspect regularly and after every storm. Make any necessary repairs.
- ▲ Check to see that water is not bypassing the inlet and undercutting the inlet or pipe. If necessary, install headwall or sandbags.
- ▲ Check for erosion at the outlet point and check the pipe for breaks or clogs. Install additional outlet protection if needed and immediately repair the breaks and clean any clogs.
- ▲ Do not allow construction traffic to cross the PSD and do not place any material on it.
- ▲ If a sediment trap has been provided, clean it out when the sediment level reaches 1/3 to 1/2 the design volume.
- ▲ The PSD should remain in place until the slope has been completely stabilized or up to 30 days after permanent slope stabilization.

### Cost

- ▲ Pipe slope drain costs are generally based upon the pipe type and size (generally, flexible PVC at \$5.00 per linear foot). Also adding to this cost are any expenses associated with inlet and outlet structures.

### Sources

- ▲ Commonwealth of Virginia - County of Fairfax, 1987. 1987 Check List For Erosion And Sediment Control - Fairfax County, Virginia.
- ▲ State of North Carolina, 1988. Erosion and Sediment Control Planning and Design Manual. North Carolina Sedimentation Control Commission, Department of Natural Resources and Community Development.
- ▲ Maryland Department of the Environment, 1991. 1991 Maryland Standards And Specifications For Soil Erosion And Sediment Control - Draft.
- ▲ Storm Water Management Manual for the Puget Sound Basin. State of Washington, Department of Ecology, 1991.
- ▲ Cost Data:
  - ▲ Draft Sediment and Erosion Control, An Inventory of Current Practices, April 20, 1990. Prepared by Kamber Engineering for the U.S. Environmental Protection Agency, Office of Water Enforcement and Permits, Washington, D.C. 20460.

# STABILIZED CONSTRUCTION ENTRANCE

September 1992

## Design Criteria

- ▲ A Stabilized Construction Entrance (SCE) is appropriate in the following locations:
  - ▲ Wherever vehicles are leaving a construction site and enter onto a public road
  - ▲ At any unpaved entrance/exit location where there is risk of transporting mud or sediment onto paved roads.
- ▲ The width should be at least 10 feet to 12 feet or the as wide as the entire width of the access. At sites where traffic volume is high the entrance should be wide enough for two vehicles to pass safely.
- ▲ The length should be between 50 to 75 feet in length.
- ▲ Flare the entrance where it meets the existing road to provide a turning radius.
- ▲ Runoff from a stabilized construction entrance should drain to a sediment trap or sediment basin.
- ▲ Pipe placed under the entrance to handle runoff should be protected with a mountable berm.
- ▲ Dust control should be provided in accordance with Section 3.2.1.

## Materials

- ▲ Crushed stone 2-inches-4-inches in diameter
- ▲ Geotextile (filter fabric) with the properties listed in Table 3 below.

TABLE 3. GEOTEXTILE REQUIREMENTS

Physical Property	Requirements
Grab Tensile Strength	220 lbs. (ASTM D1682)
Elongation Failure	60 % (ASTM D1682)
Mullen Burst Strength	430 lbs. (ASTM D3768)
Puncture Strength	125 lbs. (ASTM D751) (modified)
Equivalent Opening	Size 40-80 (US std Sieve) (CW-02215)

## Construction Specifications

- ▲ Clear all vegetation, roots and all other obstructions in preparation for grading.
- ▲ Prior to placing geotextile (filter fabric) make sure that the entrance is properly graded and compacted.

## STABILIZED CONSTRUCTION ENTRANCE

- ▲ To reduce maintenance and loss of aggregate place geotextile fabric (filter cloth) over the existing ground before placing the stone for the entrance.
- ▲ Stone should be placed to a depth of 6-inches or greater for the entire width and length of the SCE.

### Maintenance

- ▲ Inspect the measure on a regular basis and after there has been a high volume of traffic or storm event.
- ▲ Apply additional stone periodically and when repair is required.
- ▲ Immediately remove sediments or any other materials tracked onto the public roadway.
- ▲ Ensure that associated sediment control measures are in good working condition.

### Cost

- ▲ Stabilized construction entrances cost ranges from \$1,500 to \$5,000 to install.

### Sources

- ▲ Commonwealth of Virginia - County of Fairfax, 1987. 1987 Check List For Erosion And Sediment Control - Fairfax County, Virginia.
- ▲ State of North Carolina, 1988. Erosion and Sediment Control Planning and Design Manual. North Carolina Sedimentation Control Commission, Department of Natural Resources and Community Development.
- ▲ Maryland Department of the Environment, 1991. 1991 Maryland Standards And Specifications For Soil Erosion And Sediment Control - Draft.
- ▲ Storm Water Management Manual for the Puget Sound Basin. State of Washington, Department of Ecology, 1991.
- ▲ Cost Data:
  - ▲ Draft Sediment and Erosion Control, An Inventory of Current Practices, April 20, 1990. Prepared by Kamber Engineering for the U.S. Environmental Protection Agency, Office of Water Enforcement and Permits, Washington, D.C. 20460.



## FILTER FABRIC INLET PROTECTION

September 1992

### Design Criteria

- ▲ Inlet protection is appropriate in the following locations:
  - ▲ In small drainage areas (less than 1 acre) where the storm drain inlet is functional before the drainage area has been permanently stabilized.
  - ▲ Where there is danger of sediment silting in an inlet which is in place prior to permanent stabilization.
- ▲ Filter fabric inlet protection is appropriate for most types of inlets where the drainage area is one acre or less.
- ▲ The drainage area should be fairly flat with slopes of 5% or less and the area immediately surrounding the inlet should not exceed a slope of 1%.
- ▲ Overland flow to the inlet should be no greater than 0.5 cfs.
- ▲ This type of inlet protection is not appropriate for use in paved areas because the filter fabric requires staking.
- ▲ To avoid failure caused by pressure against the fabric when overtopping occurs, it is recommended that the height of the filter fabric be limited to 1.5 feet above the crest of the drop inlet.
- ▲ It is recommended that a sediment trapping sump of 1 to 2 feet in depth with side slopes of 2:1 be provided.

### Materials

- ▲ Filter fabric (see the fabric specifications for silt fence).
- ▲ Wooden stakes 2" x 2" or 2" x 4" with a minimum length of 3 feet.
- ▲ Heavy-duty wire staples at least ½ inch in length.
- ▲ Washed gravel ¾ inches in diameter.

### Construction Specifications

- ▲ Place a stake at each corner of the inlet and around the edges at no more than 3 feet apart. Stakes should be driven into the ground 18 inches or at a minimum 8 inches.
- ▲ For stability a framework of wood strips should be installed around the stakes at the crest of the overflow area 1.5 feet above the crest of the drop inlet.
- ▲ Excavate a trench of 8 inches to 12 inches in depth around the outside perimeter of the stakes. If a sediment trapping sump is being provided then the excavation may be as deep as 2 feet.
- ▲ Staple the filter fabric to the wooden stakes with heavy-duty staples, overlapping the joints to the next stake. Ensure that between 12 inches to 32 inches of filter fabric extends at the bottom so it can be formed into the trench.
- ▲ Place the bottom of the fabric in the trench and backfill the trench all the way around using washed gravel to a minimum depth of 4 inches.

## FILTER FABRIC INLET PROTECTION

### Maintenance

- ▲ Inspect regularly and after every storm. Make any repairs necessary to ensure the measure is in good working order.
- ▲ Sediment should be removed and the trap restored to its original dimensions when sediment has accumulated to  $\frac{1}{2}$  the design depth of the trap.
- ▲ If the filter fabric becomes clogged it should be replaced immediately.
- ▲ Make sure that the stakes are firmly in the ground and that the filter fabric continues to be securely anchored.
- ▲ All sediments removed should be properly disposed.
- ▲ Inlet protection should remain in place and operational until the drainage area is completely stabilized or up to 30 days after the permanent site stabilization is achieved.

### Cost

- ▲ The cost of storm drain inlet protection varies dependent upon the size and type of inlet to be protected but generally is about \$300.00 per inlet.

### Sources

- ▲ Commonwealth of Virginia - County of Fairfax, 1987. 1987 Check List For Erosion And Sediment Control - Fairfax County, Virginia.
- ▲ State of North Carolina, 1988. Erosion and Sediment Control Planning and Design Manual. North Carolina Sedimentation Control Commission, Department of Natural Resources and Community Development.
- ▲ Maryland Department of the Environment, 1991. 1991 Maryland Standards And Specifications For Soil Erosion And Sediment Control - Draft.
- ▲ Storm Water Management Manual for the Puget Sound Basin. State of Washington, Department of Ecology, 1991.
- ▲ Cost Data:
  - ▲ Draft Sediment and Erosion Control, An Inventory of Current Practices, April 20, 1990. Prepared by Kamber Engineering for the U.S. Environmental Protection Agency, Office of Water Enforcement and Permits, Washington, D.C. 20460.

## EXCAVATED GRAVEL INLET PROTECTION

September 1992

### Design Criteria

- ▲ Inlet protection is appropriate in the following locations:
  - ▲ In small drainage areas (less than 1 acre) where the storm drain inlet is functional before the drainage area has been permanently stabilized.
  - ▲ Where there is danger of sediment silting in an inlet which is in place prior to permanent stabilization.
  - ▲ Where ponding around the inlet structure could be a problem to traffic on site.
- ▲ Excavated gravel and mesh inlet protection may be used with most inlets where overflow capability is needed and in areas of heavy flows, 0.5 cfs or greater.
- ▲ The drainage area should not exceed 1 acre.
- ▲ The drainage area should be fairly flat with slopes of 5% or less.
- ▲ The trap should have a sediment trapping sump of 1 to 2 feet measured from the crest of the inlet. Side slopes should be 2:1. The recommended volume of excavation is 35 yd<sup>3</sup>/acre disturbed.
- ▲ To achieve maximum trapping efficiency the longest dimension of the basin should be oriented toward the longest inflow area.

### Materials

- ▲ Hardware cloth or wire mesh with ½ inch openings.
- ▲ Filter fabric (see the fabric specifications for silt fence).
- ▲ Washed gravel ¾ inches to 4 inches in diameter.

### Construction Specifications

- ▲ Remove any obstructions to excavating and grading. Excavate sump area, grade slopes and properly dispose of soil.
- ▲ The inlet grate should be secured to prevent seepage of sediment laden water.
- ▲ Place wire mesh over the drop inlet so that the wire extends a minimum of 1 foot beyond each side of the inlet structure. Overlap the strips of mesh if more than one is necessary.
- ▲ Place filter fabric over the mesh extending it at least 18 inches beyond the inlet opening on all sides. Ensure that weep holes in the inlet structure are protected by filter fabric and gravel.
- ▲ Place stone/gravel over the fabric/wire mesh to a depth of at least 1 foot.



## EXCAVATED GRAVEL INLET PROTECTION

### Maintenance

- ▲ Inspect regularly and after every storm. Make any repairs necessary to ensure the measure is in good working order.
- ▲ Sediment should be removed and the trap restored to its original dimensions when sediment has accumulated to  $\frac{1}{2}$  the design depth of the trap.
- ▲ Clean or remove and replace the stone filter or filter fabric if they become clogged.
- ▲ Inlet protection should remain in place and operational until the drainage area is completely stabilized or up to 30 days after the permanent site stabilization is achieved.

### Cost

- ▲ The cost of storm drain inlet protection varies dependent upon the size and type of inlet to be protected but generally is about \$300.00 per inlet.

### Sources

- ▲ Commonwealth of Virginia - County of Fairfax, 1987. 1987 Check List For Erosion And Sediment Control - Fairfax County, Virginia.
- ▲ State of North Carolina, 1988. Erosion and Sediment Control Planning and Design Manual. North Carolina Sedimentation Control Commission, Department of Natural Resources and Community Development.
- ▲ Maryland Department of the Environment, 1991. 1991 Maryland Standards And Specifications For Soil Erosion And Sediment Control - Draft.
- ▲ Storm Water Management Manual for the Puget Sound Basin. State of Washington, Department of Ecology, 1991.
- ▲ Cost Data:
  - ▲ Draft Sediment and Erosion Control, An Inventory of Current Practices, April 20, 1990. Prepared by Kamber Engineering for the U.S. Environmental Protection Agency, Office of Water Enforcement and Permits, Washington, D.C. 20460.

## BLOCK AND GRAVEL INLET PROTECTION

September 1992

### Design Criteria

- ▲ Inlet protection is appropriate in the following locations:
  - ▲ In drainage areas (less than 1 acre) where the storm drain inlet is functional before the drainage area has been permanently stabilized.
  - ▲ Where there is danger of sediment silting in an inlet which is in place prior to permanent stabilization.
- ▲ Block and gravel inlet protection may be used with most types of inlets where overflow capability is needed and in areas of heavy flows 0.5 cfs or greater.
- ▲ The drainage area should not exceed 1 acre.
- ▲ The drainage area should be fairly flat with slopes of 5% or less.
- ▲ To achieve maximum trapping efficiency the longest dimension of the basin should be oriented toward the longest inflow area.
- ▲ Where possible the trap should have sediment trapping sump of 1 to 2 feet in depth with side slopes of 2:1.
- ▲ There are several other types of inlet protection also used to prevent siltation of storm drainage systems and structures during construction, they are:
  - ▲ Filter Fabric Inlet Protection
  - ▲ Excavated Gravel Inlet Protection

### Materials

- ▲ Hardware cloth or wire mesh with  $\frac{1}{2}$  inch openings
- ▲ Filter fabric (see the fabric specifications for silt fence)
- ▲ Concrete block 4 inches to 12 inches wide.
- ▲ Washed gravel  $\frac{3}{4}$  inches to 4 inches in diameter

### Construction Specifications

- ▲ The inlet grate should be secured to prevent seepage of sediment laden water.
- ▲ Place wire mesh over the drop inlet so that the wire extends a minimum of 12 inches to 18 inches beyond each side of the inlet structure. Overlap the strips of mesh if more than one is necessary.
- ▲ Place filter fabric (optional) over the mesh and extend it at least 18 inches beyond the inlet structure.
- ▲ Place concrete blocks over the filter fabric in a single row lengthwise on their sides along the sides of the inlet. The foundation should be excavated a minimum of 2 inches below the crest of the inlet and the bottom row of blocks should be against the edge of the structure for lateral support.
- ▲ The open ends of the block should face outward not upward and the ends of adjacent blocks should abut. Lay one block on each side of the structure on its side to allow for dewatering of the pool.
- ▲ The block barrier should be at least 12 inches high and may be up to a maximum of 24 inches high and may be from 4 inches to 12 inches in depth depending on the size of block used.
- ▲ Prior to backfilling, place wire mesh over the outside vertical end of the blocks so that stone does not wash down the inlet.
- ▲ Place gravel against the wire mesh to the top of the blocks.

## BLOCK AND GRAVEL INLET PROTECTION

### Maintenance

- ▲ Inspect regularly and after every storm. Make any repairs necessary to ensure the measure is in good working order.
- ▲ Sediment should be removed and the trap restored to its original dimensions when sediment has accumulated to  $\frac{1}{2}$  the design depth of the trap.
- ▲ All sediments removed should be properly disposed of.
- ▲ Inlet protection should remain in place and operational until the drainage area is completely stabilized or up to 30 days after the permanent site stabilization is achieved.

### Cost

- ▲ The cost of storm drain inlet protection varies dependent upon the size and type of inlet to be protected but generally is about \$300.00 per inlet.

### Sources

- ▲ Commonwealth of Virginia - County of Fairfax, 1987. 1987 Check List For Erosion And Sediment Control - Fairfax County, Virginia.
- ▲ State of North Carolina, 1988. Erosion and Sediment Control Planning and Design Manual. North Carolina Sedimentation Control Commission, Department of Natural Resources and Community Development.
- ▲ Maryland Department of the Environment, 1991. 1991 Maryland Standards And Specifications For Soil Erosion And Sediment Control - Draft.
- ▲ Storm Water Management Manual for the Puget Sound Basin. State of Washington, Department of Ecology, 1991.
- ▲ Cost Data:
  - ▲ Draft Sediment and Erosion Control, An Inventory of Current Practices, April 20, 1990. Prepared by Kamber Engineering for the U.S. Environmental Protection Agency, Office of Water Enforcement and Permits, Washington, D.C. 20460.

## CHECK DAMS

September 1992

### Design Criteria

- ▲ Check dams are appropriate for use in the following locations:
  - ▲ Across swales or drainage ditches to reduce the velocity of flow.
  - ▲ Where velocity must be reduced because a vegetated channel lining has not yet been established.
- ▲ Check dams may never be used in a live stream unless approved by the appropriate government agency.
- ▲ The drainage area above the check dam should be between 2 acres and 10 acres.
- ▲ The dams must be spaced so that the toe of the upstream dam is never any higher than the top of the downstream dam.
- ▲ The center of the dam must be 6 inches to 9 inches lower than either edge, and the maximum height of the dam should be 24 inches.
- ▲ The check dam should be as much as 18 inches wider than the banks of the channel to prevent undercutting as overflow water re-enters the channel.
- ▲ Excavating a sump immediately upstream from the check dam improves its effectiveness.
- ▲ Provide outlet stabilization below the lowest check dam where the risk of erosion is greatest.
- ▲ Consider the use of channel linings or protection such as plastic sheeting or riprap where there may be significant erosion or prolonged submergence.

### Materials

- ▲ Stone 2 inches to 15 inches in diameter
- ▲ Logs 6 inches to 8 inches in diameter
- ▲ Sandbags filled with pea gravel
- ▲ Filter fabric (see the fabric specifications for silt fence)

### Construction Specifications

- ▲ Rock Check Dams
  - ▲ Place the stones on the filter fabric either by hand or using appropriate machinery; do not simply dump them in place.
  - ▲ Extend the stone 18 inches beyond the banks and keep the side slopes 2:1 or flatter.
  - ▲ Lining the upstream side of the dam with  $\frac{3}{4}$  inch to  $1\frac{1}{4}$  inch gravel 1 foot in depth is a suggested option.
- ▲ Log Check Dams
  - ▲ Logs must be firmly embedded in the ground; 18 inches is the recommended minimum depth.
- ▲ Sand Bag Check Dams
  - ▲ Be sure that bags are all securely sealed.
  - ▲ Place bags by hand or use appropriate machinery.



## CHECK DAMS

### Maintenance

- ▲ Inspect regularly and after every storm. Make any repairs necessary to ensure the measure is in good working order.
- ▲ Accumulated sediment and leaves should be removed from behind the dams and erosive damage to the channel restored after each storm or when  $\frac{1}{2}$  the original height of the dam is reached.
- ▲ All accumulated material removed from the dam shall be properly disposed.
- ▲ Replace stone as necessary for the dams to maintain their correct height.
- ▲ If sand bags are used, the fabric of the bags should be inspected for signs of deterioration.
- ▲ Remove stone or riprap if grass lined channel requires mowing.
- ▲ Check dams should remain in place and operational until the drainage area and channel are completely stabilized or up to 30 days after the permanent site stabilization is achieved.
- ▲ Restore the channel lining or establish vegetation when each check dam is removed.

### Cost

- ▲ The costs for the construction of check dams varies with the material used. Rock costs about \$100 per dam. Log check dams are usually slightly less expensive than rock check dams. All costs vary depending on the width of channel to be checked.

### Sources

- ▲ Commonwealth of Virginia - County of Fairfax, 1987. 1987 Check List For Erosion And Sediment Control - Fairfax County, Virginia.
- ▲ State of North Carolina, 1988. Erosion and Sediment Control Planning and Design Manual. North Carolina Sedimentation Control Commission, Department of Natural Resources and Community Development.
- ▲ Maryland Department of the Environment, 1991. 1991 Maryland Standards And Specifications For Soil Erosion And Sediment Control - Draft.
- ▲ Storm Water Management Manual for the Puget Sound Basin. State of Washington, Department of Ecology, 1991.
- ▲ Cost Data:
  - ▲ Draft Sediment and Erosion Control, An Inventory of Current Practices, April 20, 1990. Prepared by Kamber Engineering for the U.S. Environmental Protection Agency, Office of Water Enforcement and Permits, Washington, D.C. 20460.

## EARTH DIKE

September 1992

### Design Criteria

- ▲ Earth dikes are appropriate in the following situations:
  - ▲ To divert upslope flows away from disturbed areas such as cut or fill slopes and to divert runoff to a stabilized outlet
  - ▲ To reduce the length of the slope runoff will cross
  - ▲ At the perimeter of the construction site to prevent sediment-laden runoff from leaving the site
  - ▲ To direct sediment-laden runoff to a sediment trapping device.
- ▲ When the drainage area to the earth dike is greater than 10 acres, the United States Department of Agriculture - Soil Conservation Service (USDA - SCS) standards and specification for diversions should be consulted.
- ▲ Table 4 contains suggested dike design criteria.

TABLE 4. SUGGESTED DIKE DESIGN CRITERIA

Drainage Area	Under 5 Acres	Between 5-10 Acres
Dike Height	18 inches	30 inches
Dike Width	24 inches	36 inches
Flow Width	4 feet	6 feet
Flow Depth	12 inches	24 inches
Side Slopes	2:1 or less	2:1 or less
Grade	0.5% - 10%	0.5% - 10%

- ▲ The base for a dike 18 inches high and 24 wide at the top should be between 6 feet - 8 feet. The height of the dike is measured on the upslope side.
- ▲ If the dike is constructed using coarse aggregate the side slopes should be 3:1 or flatter.
- ▲ The channel formed behind the dike should have a positive grade to a stabilized outlet. The channel should be stabilized with vegetative or other stabilization measures.
- ▲ Grades over 10% may require an engineering design.
- ▲ Construct the dike where it will not interfere with major areas of construction traffic so that vehicle damage to the dike will be kept to the minimum.
- ▲ Diversion dikes should be installed prior to the majority of soil disturbing activity, and may be removed when stabilization of the drainage area and outlet are complete.

### Materials

- ▲ Compacted Soil
- ▲ Coarse Aggregate



## EARTH DIKE

### Construction Specifications

- ▲ Clear the area of all trees, brush, stumps or other obstructions.
- ▲ Construct the dike to the designed cross-section, line and grade making sure that there are no irregularities or bank projections to impede the flow.
- ▲ The dike should be compacted using earth moving equipment to prevent failure of the dike.
- ▲ The dike must be stabilized as soon as possible after installation.

### Maintenance

- ▲ Inspect regularly and after every storm, make any repairs necessary to ensure the measure is in good working order.
- ▲ Inspect the dike, flow channel and outlet for deficiencies or signs of erosion.
- ▲ If material must be added to the dike be sure it is properly compacted.
- ▲ Reseed or stabilize the dike as needed to maintain its stability regardless if there has been a storm event or not.

### Cost

- ▲ The cost associated with earth dike construction is roughly \$4.50 per linear foot which covers the earthwork involved in preparing the dike. Also added to this cost is approximately \$1.00 per linear foot for stabilization practices. It should be noted that for most construction projects, the cost of earth dike construction is insignificant compared to the overall earthwork project costs.

### Sources

- ▲ Commonwealth of Virginia - County of Fairfax, 1987. 1987 Check List For Erosion And Sediment Control - Fairfax County, Virginia.
- ▲ State of North Carolina, 1988. Erosion and Sediment Control Planning and Design Manual. North Carolina Sedimentation Control Commission, Department of Natural Resources and Community Development.
- ▲ Maryland Department of the Environment, 1991. 1991 Maryland Standards And Specifications For Soil Erosion And Sediment Control - Draft.
- ▲ Storm Water Management Manual for the Puget Sound Basin. State of Washington, Department of Ecology, 1991.
- ▲ Cost Data:
  - ▲ Draft Sediment and Erosion Control, An Inventory of Current Practices, April 20, 1990. Prepared by Kamber Engineering for the U.S. Environmental Protection Agency, Office of Water Enforcement and Permits, Washington, D.C. 20460.

## DRAINAGE SWALE

September 1992

### Design Criteria

- ▲ Temporary drainage swales are appropriate in the following situations:
  - ▲ To divert upslope flows away from disturbed areas such as cut or fill slopes and to divert runoff to a stabilized outlet
  - ▲ To reduce the length of the slope runoff will cross
  - ▲ At the perimeter of the construction site to prevent sediment-laden runoff from leaving the site
  - ▲ To direct sediment-laden runoff to a sediment trapping device.
- ▲ When the drainage area is greater than 10 acres the United States Department of Agriculture - Soil Conservation Service (USDA - SCS) standards and specifications for diversions should be consulted.
- ▲ Swales may have side slopes ranging from 3:1 to 2:1.
- ▲ The minimum channel depth should be between 12 inches and 18 inches.
- ▲ The minimum width at the bottom of the channel should be 24 inches and the bottom should be level.
- ▲ The channel should have a uniform positive grade between 2% and 5%, with no sudden decreases where sediments may accumulate and cause overtopping.
- ▲ The channel should be stabilized with temporary or permanent stabilization measures.
- ▲ Grades over 10% may require an engineering design.
- ▲ Construct the swale away from areas of major construction traffic.
- ▲ Runoff must discharge to a stabilized outlet.

### Materials

- ▲ Grass seed for temporary or permanent stabilization
- ▲ Sod
- ▲ Coarse aggregate or riprap

### Construction Specifications

- ▲ Clear the area of all trees, brush, stumps or other obstructions.
- ▲ Construct the swale to the designed cross-section, line and grade making sure that there are no irregularities or bank projections to impede the flow.
- ▲ The lining should be well compacted using earth moving equipment and stabilization initiated as soon as possible.
- ▲ Stabilize lining with grass seed, sod, or riprap.
- ▲ Surplus material should be properly distributed or disposed of so that it does not interfere with the functioning of the swale.
- ▲ Outlet dissipation measures should be used to avoid the risk of erosion.

### Maintenance

- ▲ Inspect regularly and after every storm, make any repairs necessary to ensure the measure is in good working order.
- ▲ Inspect the flow channel and outlet for deficiencies or signs of erosion.
- ▲ If surface of the channel requires material to be added be sure it is properly compacted.
- ▲ Reseed or stabilize the channel as needed to prevent erosion during a storm event.

## DRAINAGE SWALE

### Cost

- ▲ Drainage swale can vary widely depending on the geometry of the swale and the type of lining material:
  - ▲ Grass                      \$3.00/square yard
  - ▲ Sod                         \$4.00/square year
  - ▲ Riprap                     \$45.00/square year
- ▲ No matter which liner type is used, the entire swale must be stabilized (i.e., seeded and mulched at a cost of \$1.25/square yard).

### Sources

- ▲ Commonwealth of Virginia - County of Fairfax, 1987. 1987 Check List For Erosion And Sediment Control - Fairfax County, Virginia.
- ▲ State of North Carolina, 1988. Erosion and Sediment Control Planning and Design Manual. North Carolina Sedimentation Control Commission, Department of Natural Resources and Community Development.
- ▲ Maryland Department of the Environment, 1991. 1991 Maryland Standards And Specifications For Soil Erosion And Sediment Control - Draft.
- ▲ Storm Water Management Manual for the Puget Sound Basin. State of Washington, Department of Ecology, 1991.
- ▲ Cost Data:
  - ▲ Draft Sediment and Erosion Control, An Inventory of Current Practices, April 20, 1990. Prepared by Kamber Engineering for the U.S. Environmental Protection Agency, Office of Water Enforcement and Permits, Washington, D.C. 20460.

# TEMPORARY SEDIMENT TRAP

September 1992

## Design Criteria

- ▲ Temporary sediment traps are appropriate in the following locations:
  - ▲ At the outlet of the perimeter controls installed during the first stage of construction.
  - ▲ At the outlet of any structure which concentrates sediment-laden runoff, e.g. at the discharge point of diversions, channels, slope drains, or other runoff conveyances.
  - ▲ Above a storm water inlet that is in line to receive sediment-laden runoff.
- ▲ Temporary sediment traps may be constructed by excavation alone or by excavation in combination with an embankment.
- ▲ Temporary sediment traps are often used in conjunction with a diversion dike or swale.
- ▲ The drainage area for the sediment trap should not exceed 5 disturbed acres.
- ▲ The trap must be accessible for ease of regular maintenance which is critical to its functioning properly.
- ▲ Sediment traps are temporary measures and should not be planned to remain in place longer than between 18 and 24 months.
- ▲ The capacity of the sedimentation pool should provide storage volume for 3,600 cubic feet/acre drainage area.
- ▲ The outlet should be designed to provide a 2 foot settling depth and an additional sediment storage area 1 ½ feet deep at the bottom of the trap.
- ▲ The embankment may not exceed 5 feet in height.
- ▲ The recommended minimum width at the top of the embankment is between 2 feet and 5 feet.
- ▲ The minimum recommended length of the weir is between 3 feet and 4 feet, and the maximum is 12 feet in length.
- ▲ Table 5 illustrates the typical relationship between the embankment height, the height of the outlet ( $H_o$ ), and the width (W) at the top of the embankment.

TABLE 5. EMBANKMENT HEIGHT vs. OUTLET HEIGHT AND WIDTH

H	$H_o$	W
1.5	0.5	2.0
2.0	1.0	2.0
2.5	1.5	2.5
3.0	2.0	2.5
3.5	2.5	3.0
4.0	3.0	3.0
4.5	3.5	4.0
5.0	4.0	4.5

## Materials

- ▲ Filter fabric (see fabric requirement for silt fence)
- ▲ Coarse aggregate or riprap 2 inches to 14 inches in diameter
- ▲ Washed gravel ¾ to 1 ½ inches in diameter
- ▲ Seed and mulch for stabilization



## TEMPORARY SEDIMENT TRAP

### Construction Specifications

- ▲ Clear the area of all trees, brush, stumps or other obstructions.
- ▲ Construct the embankment in 8 inch lifts compacting each lift with the appropriate earth moving equipment. Fill material must be free of woody vegetation, roots, or large stones.
- ▲ Keep cut and fill slopes between 3:1 and 2:1 or flatter.
- ▲ Line the outlet area with filter fabric prior to placing stone or gravel.
- ▲ Construct the gravel outlet using heavy stones between 6 inches and 14 inches in diameter and face the upstream side with a 12 inch layer of  $\frac{3}{4}$  inch to 1  $\frac{1}{2}$  inch washed gravel on the upstream side.
- ▲ Seed and mulch the embankment as soon as possible to ensure stabilization.

### Maintenance

- ▲ Inspect regularly and after every storm. Make any repairs necessary to ensure the measure is in good working order.
- ▲ Frequent removal of sediment is critical to the functioning of this measure. At a minimum sediment should be removed and the trap restored to its original volume when sediment reaches  $\frac{1}{3}$  of the original volume.
- ▲ Sediment removed from the trap must be properly disposed.
- ▲ Check the embankment regularly to make sure it is structurally sound.

### Cost

- ▲ Costs for a sediment trap vary widely based upon their size and the amount of excavation and stone required, they usually can be installed for \$500 to \$7,000.

### Sources

- ▲ Commonwealth of Virginia - County of Fairfax, 1987. 1987 Check List For Erosion And Sediment Control - Fairfax County, Virginia.
- ▲ State of North Carolina, 1988. Erosion and Sediment Control Planning and Design Manual. North Carolina Sedimentation Control Commission, Department of Natural Resources and Community Development.
- ▲ Maryland Department of the Environment, 1991. 1991 Maryland Standards And Specifications For Soil Erosion And Sediment Control - Draft.
- ▲ Storm Water Management Manual for the Puget Sound Basin. State of Washington, Department of Ecology, 1991.
- ▲ Cost Data:
  - ▲ Draft Sediment and Erosion Control, An Inventory of Current Practices, April 20, 1990. Prepared by Kamber Engineering for the U.S. Environmental Protection Agency, Office of Water Enforcement and Permits, Washington, D.C. 20460.

## TECHNICAL SPECIFICATIONS SEEDING

**Description.** This item shall consist of furnishing and applying lime, fertilizer, seed, mulch cover, asphalt, and water according to these specifications at locations shown on the plans or as directed.

The work under this item shall be accomplished as soon as practicable after the grading in an area has been completed in order to deter erosion of the roadway and siltation of streams.

**Materials.** (a) Lime shall be agricultural grade ground limestone or equivalent as approved by the Engineer.

(b) Fertilizer shall be a commercial grade, uniform in composition, free-flowing, and suitable for application with mechanical equipment. It shall be delivered to the site in labeled containers conforming to current Arkansas fertilizer laws and bearing the name, trademark, and warranty of the producer.

(c) Except as modified herein, the seed shall comply with the current rules and regulations of the Arkansas State Plant Board and the germination test shall be valid on the date the seed is used. It shall have a minimum of 98% pure seed and 85% germination by weight, and shall contain no more than 1% weed seeds. A combined total of 110 noxious weed seeds shall be the maximum amount allowed per kg (50 per pound) of seed with the following exceptions: Johnson grass seed, wild onion seed, wild garlic seed, field bindweed seed, nut grass seed, sickle pod seed, sesbania seed, indigo seed, morning-glory seed, and cocklebur seed will not be allowed in any amount. Seed shall be furnished in sealed, standard containers. Seed that has become wet, moldy, or otherwise damaged in transit or in storage will not be acceptable.

Legumes shall be inoculated with an approved culture as recommended by the manufacturer, just prior to seeding.

Seed shall be composed of the varieties and amounts by weight as shown below.

Seed planted between June 16 and August 31 may require more water than that specified in subsection (f) in order to survive. Therefore, watering shall continue after germination until growth is established.

The seeding mixture may be altered by the Engineer in selected areas with no adjustment in contract price. The alteration shall be on an equivalent cost basis.



Seed Variety: kg/ha lbs./acre

Group I

Districts 1, 2, 5, 6, and 10

March 1 - June 15

Bermuda Grass (Common) unhulled	10	10
Bermuda Grass (Common) hulled	5	5
Lespedeza (Kobe)	40	35

June 16 - August 31

Bermuda Grass (Common) unhulled	10	10
Bermuda Grass (Common) hulled	5	5
Weeping Love Grass (Eragrostis Curvula)	10	10

September 1 - February 28/29

Wheat	35	30
Crimson Clover (Dixie)	20	20
Bermuda Grass (Common) unhulled	20	20
Lespedeza (Kobe)	40	35

Group II

Districts 3, 4, 7, 8, and 9

March 15 - June 15

Bermuda Grass (Common) unhulled	10	10
Bermuda Grass (Common) hulled	5	5
Lespedeza (Korean)	35	30

June 16 - August 31

Bermuda Grass (Common) unhulled	10	10
Bermuda Grass (Common) hulled	5	5
Weeping Love Grass (Eragrostis Curvula)	10	10

September 1 - March 14

Annual Rye Grass or other Cereal Grasses	35	30
Crimson Clover (Dixie)	20	20
Bermuda Grass (Common) unhulled	20	20
Lespedeza (Korean)	35	30

(d) Mulch cover shall consist of straw from threshed rice, oats, wheat, barley, or rye; of wood excelsior; or of hay obtained from various legumes or grasses, such as lespedeza, clover, vetch, soybeans, bermuda, carpet sedge, bahia, fescue, or other legumes or grasses; or a combination thereof. Mulch shall be dry and reasonably free from Johnson grass or other noxious weeds, and shall not be excessively brittle or in an advanced state of decomposition. All material will be inspected and approved prior to use.

(e) Tackifiers. Tackifiers used in mulch anchoring shall be of such quality that the mulch cover will be bound together to form a cover mat that will stay

intact under normal climatic conditions.

All tackifiers used shall have prior approval or be listed on the Owner's Qualified Products List (QPL).

(f) Water shall be of irrigation quality and free of impurities that would be detrimental to plant growth.

**Construction Requirements. (a) Seedbed Preparation.** Areas to be seeded shall be dressed to the shape and section shown on the plans. If the plans call for replacing topsoil, this shall be done before any preparations for seeding. Before beginning the seedbed preparation, soil samples shall be obtained from each major soil area (such as cut backslope or fill foreslope) by the Engineer for lime requirement analysis.

Lime, at the rate determined by the lime requirement test, shall be uniformly spread on areas to be seeded prior to their being roughened or scarified. The seedbed shall be thoroughly pulverized by means of disk harrows or other approved methods, thoroughly mixing lime and soil to a depth of not less than 100 mm (4") (50 mm [2"] for slopes 4:1 or steeper) below finish slope elevation. Regardless of the pulverizing method used, the soil shall be broken with the contour of the slope. Objectionable foreign matter shall be removed and the soil left in a suitable horticultural condition to receive the fertilizer and seed. Water may be applied before, during, and after seedbed preparation, as directed by the Engineer, in order to maintain the desired moisture content in the soil.

When no lime is required, seedbed preparation shall be accomplished as specified above regardless of the method used in the distribution of fertilizer, seed, and mulch cover.

**(b) Fertilization.** Fertilizer shall be applied at the rate of 900 kg/ha (800 pounds per acre) of 10-20-10, or the equivalent amount of plant food. Fertilizer shall be uniformly incorporated into the soil alone or in conjunction with the required lime. If the Contractor so elects, the fertilizer may be drilled into the soil or combined with the seed in the hydro-seeding operation.

**(c) Seeding. (1) Broadcasting.** Broadcast sowing may be accomplished by hand seeders or by approved power equipment. Either method shall result in uniform distribution and no work shall be performed during high winds. The area seeded shall be lightly firmed with a cultipacker immediately after broadcasting.

**(2) Drilled in Rows.** When seed is drilled in rows, the rows shall be horizontal (parallel to contour lines). Fertilizer and seed shall not be drilled together and shall not be mixed.

**(3) Hydro-seeding.** If a hydro-seeder is used for seeding, fertilizer and seed may be incorporated into one operation but a maximum of 95 kg of fertilizer shall be permitted for each 1500 L (maximum of 800 pounds for each 1500 gallons) of water. If the Contractor so elects, the fertilizer may be applied during preparation of the seedbed. The area shall be lightly firmed with a cultipacker immediately before hydro-seeding.



(d) **Mulch Cover.** Mulch cover shall be applied at the rate of 4500 kg/ha (4000 pounds per acre) immediately after seeding and shall be spread uniformly over the entire area by approved power mulching equipment. When approved by the Engineer, the Contractor may use hand methods to apply mulch cover to small or inaccessible areas. If the Contractor so elects, an approved mulching machine may be used whereby the application of mulch cover and tackifier may be combined into one operation. If this method is used, no change in application rates will be allowed. In its final position, the anchored mulch shall be loose enough to allow air to circulate, but compact enough to partially shade the ground and reduce the impact of rainfall on the surface of the soil. Care shall be taken to prevent tackifier materials from discoloring or marking structures, pavements, utilities, or other plant growth. Removal of any objectionable discoloration shall be at no cost to the Owner.

(e) **Mulch Anchoring.** Immediately following or during the application of the mulch cover on seeded areas, the mulch shall be anchored by one of the following methods:

- **Tracking or Roller Method.** The mulch shall be effectively pressed into the soil using steel cleated track or cleated roller equipment. The anchoring shall be performed so that the grooves formed are perpendicular to the flow of water down backslopes and foreslopes. The equipment and method used shall produce acceptable results.
- **Asphalt Tackifier.** Asphalt shall be applied at the rate of approximately 0.2 L/sq m (0.05 gallon per square yard). Application shall be made using a pressure distributor to ensure constant and uniform distribution. The use of asphalt may be reduced or eliminated by the Engineer at selected locations.
- **Other Tackifiers.** Tackifiers listed on the QPL shall be applied according to the rates recommended in the QPL.

The method used shall be at the Contractor's option unless otherwise specified or directed. In lieu of separate application of tackifiers, the Contractor may use equipment that combines the application of mulch and tackifier into one operation. Application shall be at the specified rates.

(f) **Water.** After application of the mulch cover, water shall be applied in sufficient quantity, as directed by the Engineer, to thoroughly moisten the soil to the depth of pulverization and then as necessary to germinate the seed.

When directed by the Engineer, the Contractor shall apply water in an amount such that, in conjunction with any rainfall, the seeded and mulched areas will receive an amount equivalent to a minimum of 25 mm (1") of water each week beginning the week after seeding and continuing for a minimum of three (3) weeks. (25 mm [1"] of water is equivalent to 250 cu m or 250 kL per ha [27 M Gallons per acre].)

Failure to meet this requirement will result in a partial withholding and/or recovery of payments for the seeding and mulch cover. Additional work and materials required due to the Contractor's negligence in maintaining completed work or failure to water grass as directed shall be accomplished at no cost to the

Department. If payments are withheld and subsequently a stand of grass satisfactory to the Engineer develops, payments will be released.

The Contractor shall have on the project before seeding is started such equipment of adequate capacity and a suitable water supply to achieve the desired moisture level in the soil. The time required for application of water will not be included in the computations of contract time for completion of the project provided all other work under the Contract has been completed.

(g) For areas seeded in the September 1-February 28/29 or September 1-March 14 season, final acceptance will be delayed until an acceptable stand of grass of uniform color and density is established to the satisfaction of the Engineer. The soil condition shall be suitable for preparation of the seedbed according to the above requirements in the areas to be seeded during the September 1-February 28/29 or September 1-March 14 season.

(h) Before final acceptance, the Contractor shall repair or replace any seeding or mulching that is defective or damaged. If the defect or damage is due to the Contractor's negligence, the work shall be done at no additional cost to the Owner. If the damage or defect is not the Contractor's fault, the work will be measured and paid for according to these specifications.



ARKANSAS  
Department of Environmental Quality

**NOTICE OF INTENT  
FOR DISCHARGES OF STORMWATER  
ASSOCIATED WITH LARGE CONSTRUCTION ACTIVITY  
AUTHORIZED UNDER NPDES GENERAL PERMIT ARR150000**

The enclosed form may be used to obtain coverage under NPDES general permit ARR150000 for discharges of stormwater associated with large construction activity at any site or common plan of development or sale that will result in the disturbance of five (5) or more acres of total land area.

Return the completed form to:

Arkansas Department of Environmental Quality  
Permit Branch, Office of Water Quality  
5301 Northshore Drive  
North Little Rock, AR 72118

Unless notified by the Director to the contrary, dischargers who submit a complete Notice of Intent in accordance with the requirements of this permit are authorized to discharge stormwater from construction sites under the terms and conditions of this permit two weeks after the date the NOI is postmarked.

As required by ADEQ Regulation No. 9, an initial permit fee of \$200.00 must be submitted with this NOI. Subsequent annual fees of \$200.00 per year will be billed by the Department. Failure to remit the required permit fee may be grounds for the Director to deny coverage under this general permit, and to require the owner or operator to apply for an individual NPDES permit.

**NOTE:** A STORMWATER POLLUTION PREVENTION PLAN (SWPPP) SHALL BE PREPARED PRIOR TO SUBMITTAL OF THIS NOI PER PART II.A OF THE GENERAL PERMIT. THE SWPPP MUST BE SUBMITTED FOR REVIEW ALONG WITH THIS NOI FOR LARGE CONSTRUCTION SITES PER PART I.B.6.B OF THE GENERAL PERMIT.

For additional information please contact:

Stormwater Runoff Engineer  
Ph.: (501) 682-0623  
Fax: (501) 682-0880  
website: [www.adeq.state.ar.us](http://www.adeq.state.ar.us)

## INSTRUCTIONS

### I. How to Determine Latitude and Longitude:

1. If a physical address is known go to [www.teraserver-usa.com](http://www.teraserver-usa.com).
2. Select Advanced Find
3. Select Address
4. Input address
5. Click on Aerial Photo
6. Click on the Info link at the top of the page
7. Note the Latitude and Longitude are in Decimal Coordinates.
8. Go to [www.geology.enr.state.nc.us/gis/latlon.html](http://www.geology.enr.state.nc.us/gis/latlon.html) to convert coordinates to Degrees, Minutes, and Seconds.

NOTE: If a physical address does not exist you may find the coordinates in the Legal Description of the property.



## II. How to Determine your Ultimate Receiving Waters:

1. Locate the county of your project.
2. Find the numbered segment overlaying the county. For example 2C overlays most of Saline County.
3. Match the number from the segment to the one of the numbered Ultimate Receiving Waters. For example: A project located in Western Saline County is in segment 2C. The “2” determines that the Ultimate Receiving Water for the project is the Ouachita River.

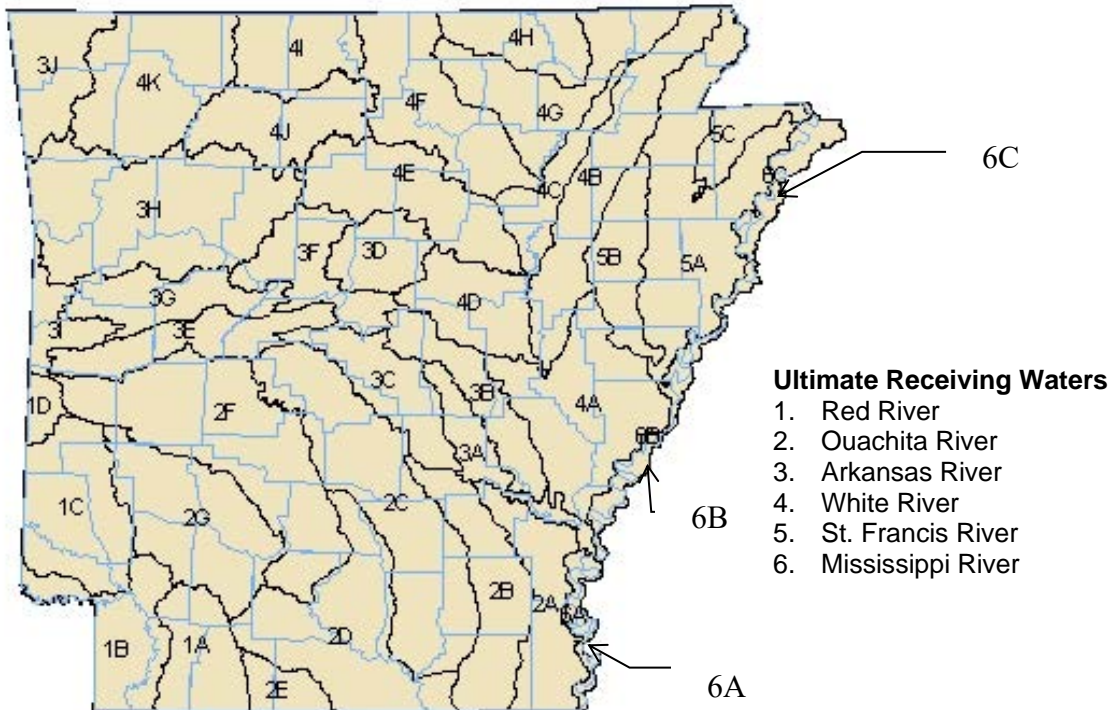

## III. How to determine if the receiving stream is on the approved Arkansas 303(d) List:

1. Go to [www.epa.gov/owow/tmdl](http://www.epa.gov/owow/tmdl)
2. Using the map of the United States, click on Arkansas.
3. Using the “Waters Listed by Waterbody Type” links search for your receiving stream.
4. If your receiving stream is not listed, than your receiving stream is not on the approved Arkansas 303(d) List.
5. If your receiving stream is listed, then click on the links for that receiving stream to determine the pollutants causing the impairment. If the receiving stream is listed as an impaired for any pollutant, you must incorporate into the SWPPP any additional BMPs needed to sufficiently protect water quality. The Department may require additional BMPs.
6. Once a determination is made that your receiving stream is on the approved Arkansas 303(d) List, than you must determine if the receiving stream has an approved TMDL by using the “Approved TMDLs by Pollutant since January 1, 1996” links toward the bottom of the webpage.
  - i. If the approved TMDL has established a specific numeric allocation that would apply to a project’s discharges, you will be required to incorporate the allocation into your SWPPP and implement steps to meet the allocation.
  - ii. If the approved TMDL has assigned to the facility, quarterly monitoring must be submitted to the Department demonstrating compliance with the assigned Waste Load Allocation.

## IV. How to obtain information in regard to Endangered Species:

Contact the U.S. Fish and Wildlife Service at (501) 513-4470 or [www.fws.gov/arkansas-es](http://www.fws.gov/arkansas-es).



Arkansas Department of Environmental Quality  
Permits Branch, Office of Water Quality  
5301 Northshore Drive  
North Little Rock, AR 72118  
(501) 682-0623

NOTICE OF INTENT  
FOR DISCHARGERS OF STORMWATER RUNOFF  
ASSOCIATED WITH LARGE CONSTRUCTION ACTIVITY  
AUTHORIZED UNDER NPDES GENERAL PERMIT ARR150000

Application Type: New  Renewal  (Permit Tracking Number ARR(\_\_\_\_))

I. PERMITTEE/OPERATOR INFORMATION

Permittee (Legal Name): Springhill Hwy 5 Developments LLC

Operator Type:

Permittee Mailing Address: 816 East Oak Street

STATE

PARTNERSHIP

Permittee City: Conway

FEDERAL

CORPORATION\*

Permittee State: AR Zip: 72032

SOLE PROPRIETORSHIP

Permittee Telephone Number: 501-428-3866

PUBLIC

OTHER

Permittee Fax Number \_\_\_\_\_

Permittee E-mail Address masseydevelopmentgroup@hotmail.com

\*State of Incorporation: AR

\* The legal name of the Permittee must be identical to the name listed with the Arkansas Secretary of State.

II. INVOICE MAILING INFORMATION

Invoice Contact Person: Lance Massey

City: Conway

Invoice Mailing Company: Springhill Hwy 5 Developments LLC

State: AR Zip: 72032

Invoice Mailing Address: 816 East Oak Street

Telephone: 501-428-3866

III. FACILITY/PROJECT CONSTRUCTION SITE INFORMATION

1 acre = 43,560 square feet

Project Name: Hillcrest Addition

Contact Person: Lance Massey

Project County: Saline

Project Physical Address: Springhill Road, 0.4 miles North of the intersection of Springhill Rd. and Hurricane Gardens Dr.

Directions to the Project: Heading West on I-30, take exit 123. Continue 1.9 miles, then turn

Project City: Bryant Zip: 72022

Right onto Springhill Road. Construction entrance to the Project is on the left in approximately 1.4 miles.

Telephone Number: 501-428-3866

Project Estimated

Total amount of soil to be disturbed

Start Date: August 2024

(estimate to nearest 1/2 acre): 4.89 ac

Project Estimated

End Date: September 2025

Total Project Acreage

(Estimate to nearest 1/2 acre): 4.89 ac

Project Latitude: 34 degrees 37 minutes 53.93 seconds N

Project Longitude: -92 degrees 30 minutes 55.57 seconds W

Type of Project: Subdivision  School  Other: \_\_\_\_\_

Facility SIC Code(s): 1521

NAICS Code (s): 236115

Is the Project part of a larger common plan of development or sale? Yes  No

Linear Project Starting Coordinates (if applicable):

Linear Project Ending Coordinates (if applicable):

Latitude:

Longitude:

Latitude:

Longitude:

OFFICE OF WATER QUALITY  
5301 NORTHSHORE DRIVE / NORTH LITTLE ROCK, ARKANSAS 72118 / PHONE 501-682-0623 / FAX 501-682-0910  
www.adeq.state.ar.us

Large Construction NOI / Revision date 09/2014

**Arkansas Department of Environmental Quality  
Permits Branch, Office of Water Quality  
5301 Northshore Drive  
North Little Rock, AR 72118  
(501) 682-0623**

---

---

**IV. DISCHARGE INFORMATION**

Name of Receiving Stream (i.e. an unnamed tributary of Mill Creek, thence into Mill Creek; thence into Arkansas River):  
Unnamed tributary Hurricane Lake; thence into Hurricane Lake; thence into Hurricane Creek; thence into the Saline River; the Saline River empties into the Ouachita River.

Choose Your Ultimate Receiving Stream: Red River  Ouachita River  Arkansas River   
White River  St. Francis River  Mississippi River

Name of Receiving Municipal Storm Sewer System (If applicable): City of Bryant

Will you be conducting any in-stream or wetted area activities (i.e. re-routing, trenching, stabilizing, sloping, etc.)?  Yes  No

If yes, have you obtained an approval for a Short Term Activity Authorization (STAA) from the Department?  Yes  No

Is the stream or wetted area considered "Waters of the United States"?  Yes  No

If yes, have you obtained a 404 permit from the U.S. Army Corps of Engineers?  Yes  No

For information regarding what constitutes "Waters of the United States" please contact the U.S. Army Corps of Engineers, Regulatory Division in the District in which the activity is to take place. Below is the contact information for the three U.S. Army Corps of Engineers Districts in the State:

Little Rock District      Ph: (501) 324-5295, [CESWL-Regulatory@usace.army.mil](mailto:CESWL-Regulatory@usace.army.mil)  
Vicksburg District:      Ph: (601) 631-7071, [regulatory@usace.army.mil](mailto:regulatory@usace.army.mil)  
Memphis District:      Ph: (901) 544-3471, [MemphisPAO@usace.army.mil](mailto:MemphisPAO@usace.army.mil)

---

---

**V. FACILITY/SITE PERMIT INFORMATION**

NPDES Individual Permit Number (If Applicable): AR00

NPDES General Permit Number (If Applicable): ARG

NPDES General Industrial Stormwater Permit Number (If Applicable): ARR00

NPDES General Construction Stormwater Permit Number (If Applicable): ARR15

---

---

**VI. OTHER INFORMATION:**

Location of SWPPP on the Construction Site: At Construction Entrance  
Consultant Company: Lemons Engineering Consultants, Inc.  
Consultant Contact Name: Tim Lemons  
Consultant Email Address: [eburke@lemonsengineering.com](mailto:eburke@lemonsengineering.com)  
Consultant Address: 204 Cherry Street City: Cabot State: AR Zip: 72023  
Consultant Phone Number: 1-501-605-7565 Number: 1-501-941-0959

**Arkansas Department of Environmental Quality  
Permits Branch, Office of Water Quality  
5301 Northshore Drive  
North Little Rock, AR 72118  
(501) 682-0623**

---

**VII. CERTIFICATION OF OPERATOR**

“I certify that, if this facility is a corporation, it is registered with the Secretary of State of Arkansas. Please provide the full name of corporation if different than that listed in Section I above.”

“I certify that as a whole the stormwater discharge(s), and the construction and implementation of Best Management Practices (BMP’s) to control stormwater runoff, are not likely to adversely affect species of critical habitat for a listed species.”

“I certify that a stormwater pollution prevention plan has been prepared for this facility in accordance with Part II.A of this permit, which provides for, or will provide for, compliance with local sediment and erosion plans, local stormwater permits or stormwater management plans, in accordance with Part II.A.4.c of this permit.”

“I certify that the cognizant official designated in Part VIII of this Notice of Intent is qualified to act as a duly authorized representative under the provisions of 40 CFR 122.22(b). If no cognizant official has been designated, I understand that the Department will accept reports signed by the applicant”

“I certify under penalty of law that this document and all attachments such as Inspection Form were prepared under my direction or supervision in accordance with a system designed to ensure that qualified personnel properly gather and evaluate the information submitted. Based on my inquiry of the person or persons who manage the system, or those persons directly responsible for gathering the information, the information submitted is, to the best of my knowledge and belief, true, accurate, and complete. I am aware that there are significant penalties for submitting false information, including the possibility of fine and imprisonment for knowing violations.”

Responsible Official Printed Name: Lance Massey Title: Developer/Construction Manager  
Responsible Official Signature: \_\_\_\_\_ Date: 7-9-2024

---

**VIII. COGNIZANT OFFICIAL**

Cognizant Official Printed Name: Lance Massey Title: Developer/Construction Manager  
Cognizant Official Signature: \_\_\_\_\_ Telephone: 501-428-3866

---

**IX. PERMIT REQUIREMENT VERIFICATION**

Please check the following to verify completion of permit requirements.

	Yes	No*
Submittal of Complete NOI?	<input checked="" type="checkbox"/>	<input type="checkbox"/>
Submittal of Required Permit Fee?	<input checked="" type="checkbox"/>	<input type="checkbox"/>
Check Number: _____		
Complete SWPPP?	<input checked="" type="checkbox"/>	<input type="checkbox"/>

**\* If you answer No to any of the above questions, then a permit can not be issued!**