

# CONSTRUCTION PLANS FOR LITTLE CAESARS REYNOLDS ROAD BRYANT, ARKANSAS

## UTILITY AND GOVERNING AGENCIES CONTACT LIST

**WATER COMPANY**  
CITY OF BRYANT PUBLIC WORKS  
TIM FOURNIER  
210 SW 3RD STREET  
BRYANT, AR 72022  
(501) 943-0469

**DEPARTMENT OF TRANSPORTATION**  
ARKANSAS DEPARTMENT OF TRANSPORTATION  
(501) 569-2000

**SANITARY SEWER COMPANY**  
CITY OF BRYANT PUBLIC WORKS  
TIM FOURNIER  
210 SW 3RD STREET  
BRYANT, AR 72022  
(501) 943-0469

**PLANNING DEPARTMENT**  
CITY OF BRYANT COMMUNITY DEVELOPMENT  
COLTON LEONARD  
210 SW 3RD STREET  
BRYANT, AR 72022  
(501) 943-0469

**FIRE MARSHAL**  
CITY OF BRYANT FIRE DEPARTMENT  
THOMAS HAMMOND  
312 ROYA LANE  
BRYANT, AR 72022  
(501) 943-0397

**ZONING DEPARTMENT**  
CITY OF BRYANT COMMUNITY DEVELOPMENT  
COLTON LEONARD  
210 SW 3RD STREET  
BRYANT, AR 72022  
(501) 943-0469

**EROSION CONTROL**  
CITY OF BRYANT ENGINEERING/CONSTRUCTION  
SCOTT CHANDLER  
210 SW 3RD STREET  
BRYANT, AR  
501 943-0469

**PHONE COMPANY**  
AT & T  
(800) 288-2020

**POWER COMPANY**  
ENTERGY  
(501) 368-3749

**GAS COMPANY**  
CENTERPOINT ENERGY  
(800)992-7552

**CABLE COMPANY**  
XFINITY  
(800) 934-6489

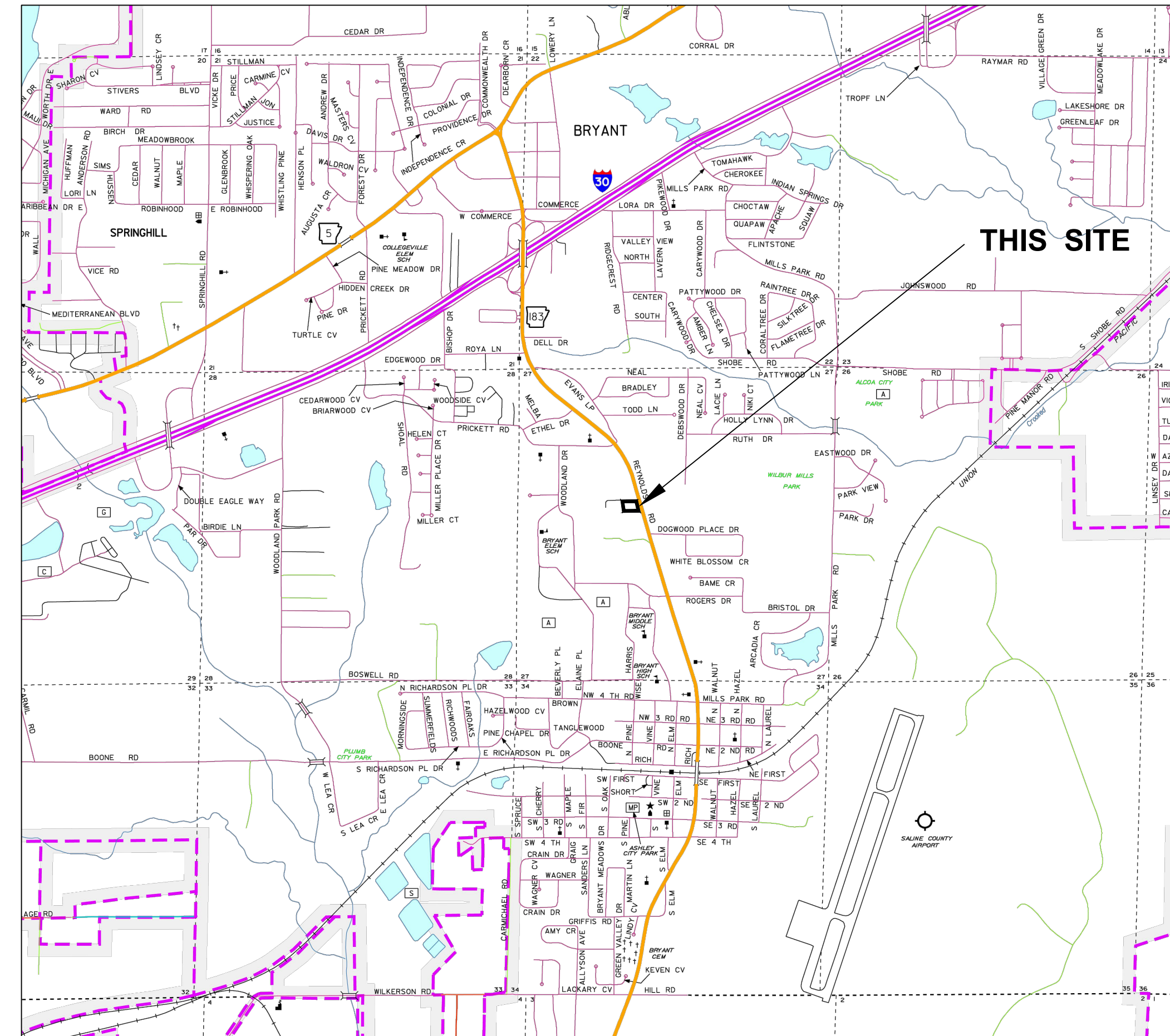

## GENERAL SITE CONSTRUCTION NOTES:

1. THE CONTRACTOR SHALL CONTROL EROSION ON THE SITE. ALL SLOPES SHALL BE FERTILIZED, SEEDED AND MULCHED (OR LANDSCAPED) AS DIRECTED BY THE OWNER OR HIS REPRESENTATIVE. THE SITE SHALL BE GRADED TO MAINTAIN POSITIVE DRAINAGE DURING CONSTRUCTION. THE WATER SHALL NOT BE ALLOWED TO POND.
2. THE CONTRACTOR SHALL COORDINATE WITH EACH UTILITY COMPANY PRIOR TO ANY EXCAVATION. ANY DAMAGE TO UTILITY LINES CAUSED BY THE CONTRACTOR OPERATIONS SHALL BE REPAIRED AT THE CONTRACTORS EXPENSE. THE CONTRACTOR SHALL VERIFY THE HORIZONTAL AND VERTICAL ALIGNMENT OF EXISTING AND PROPOSED STORM SEWER, SANITARY SEWER AND WATER LINES TO ENSURE THAT THEY ARE INSTALLED WITH ADEQUATE COVER AND CLEARANCE.
3. THE CONTRACTOR SHALL COMPLY WITH ALL APPLICABLE LAWS, CODES AND ORDINANCES GOVERNING WORK AT THIS TYPE.
4. THE CONTRACTORS ATTENTION IS SPECIFICALLY CALLED TO THE LOCATION OF THE EXISTING IMPROVEMENTS. THE CONTRACTOR SHALL BE SOLELY RESPONSIBLE FOR DAMAGING ANY EXISTING IMPROVEMENTS WHICH ARE TO REMAIN PRIOR TO SUBMITTING HIS BID. THE CONTRACTOR SHALL REVIEW THE PLANS AND SPECIFICATIONS. HE SHALL VISIT THE SITE AND INSPECT THE CONDITION OF THE SITE AND THE ADJACENT IMPROVEMENTS.
5. THE CONTRACTOR SHALL CALL "ONE-CALL" FOR LOCATION OF ALL UTILITIES PRIOR TO COMMENCEMENT OF ANY EXCAVATION.
6. ANY EXCESS EXCAVATED MATERIAL SHALL BE STOCKPILED OR PLACED IN AREAS AS DIRECTED. ALL FILLS ON SITE IN AREAS OF FUTURE BUILDING CONSTRUCTION SHALL BE MADE IN 8" LIFTS AND COMPACTED TO 95% MODIFIED PROCTOR DENSITY.

## INDEX OF SHEETS

TITLE SHEET	C1
TOPOGRAPHIC SURVEY	V1
SITE PLAN	C2
GRADING PLAN	C3
UTILITY PLAN	C4
EROSION CONTROL PLAN	C5
SITE DETAILS	C6
WATER AND SEWER LINE DETAILS	C7

OWNER & DEVELOPER:  
OBWAT HOLDINGS, LLC  
7500 LANDERS ROAD  
SHERWOOD, AR. 72117

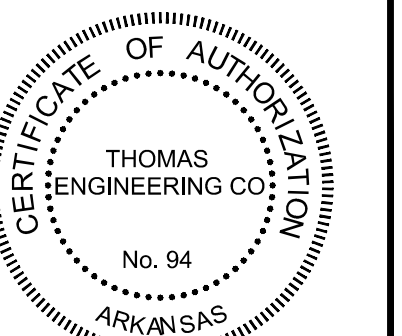
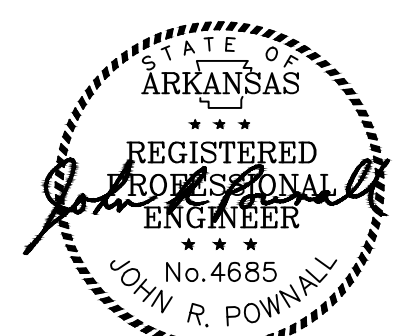

## A DEVELOPMENT OF OBWAT HOLDINGS, LLC

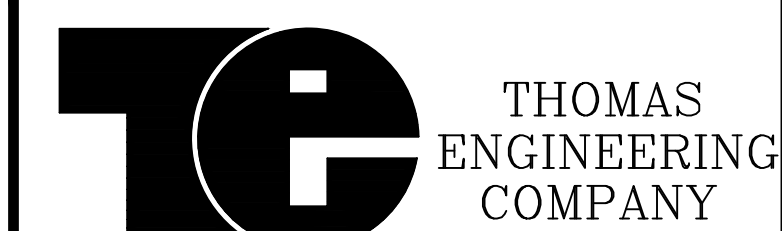

**TITLE SHEET**  
**LOT 1**  
**LITTLE CAESARS ADDITION**  
**BRYANT, ARK.**

3810 LOOKOUT ROAD, N. LITTLE ROCK, AR. 72116  
TEL: 501-753-4463 FAX: 501-753-6814

APPROVED JRP	DRAWN BY JRP	DATE 6/20/24	SHEET NO. C1
SCALE NTS			

LITTLE CAESARS-BRYANT-23-0165.dwg

PLOTTED: 6/20/2024

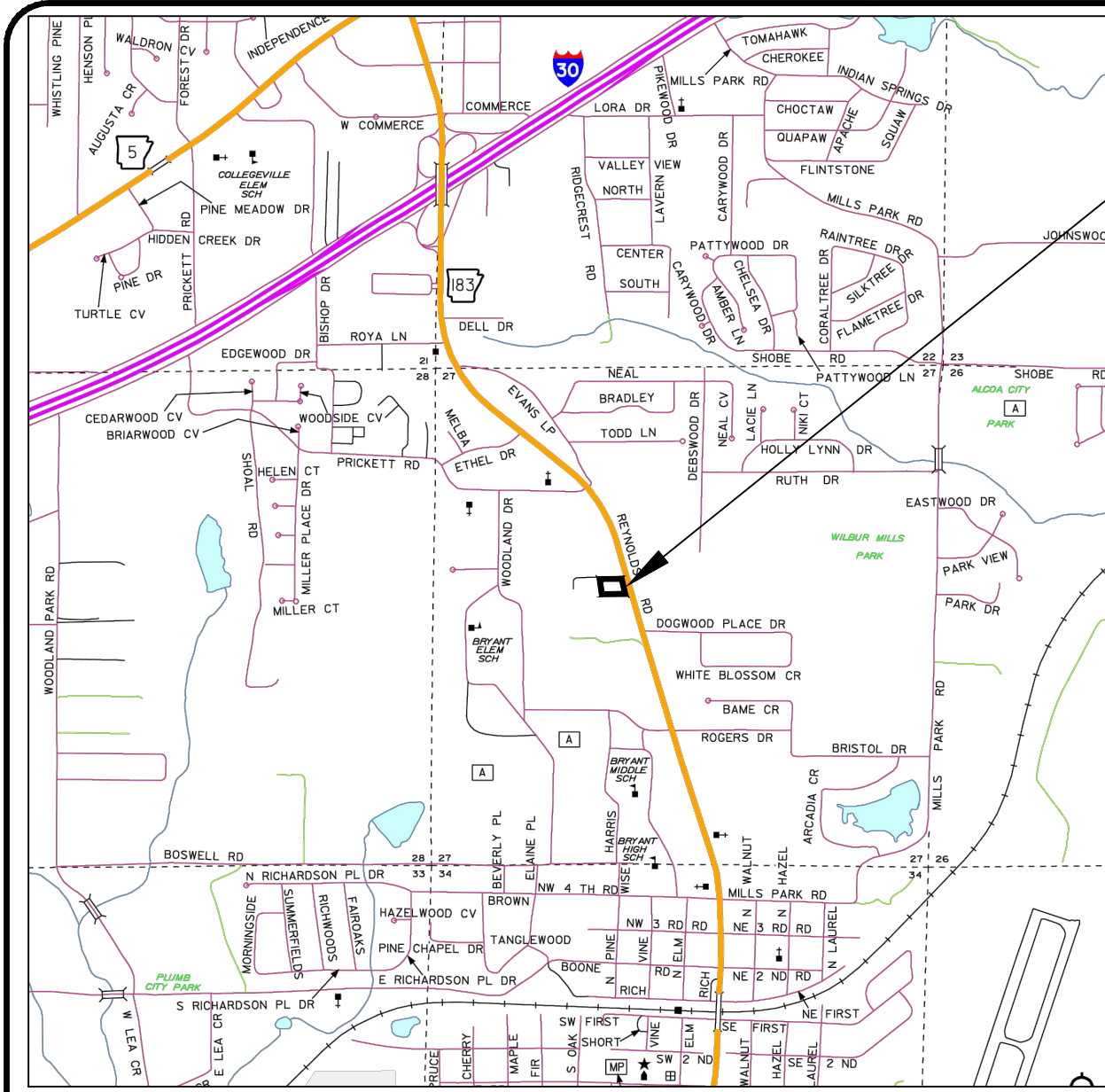

VICINITY MAP

THIS SITE



**SURVEY LEGAL DESCRIPTION.**

PART OF THE SE1/4 NW1/4 OF SECTION 27, TOWNSHIP 1 SOUTH, RANGE 14 WEST, IN THE CITY OF BRYANT, SALINE COUNTY, ARKANSAS, MORE PARTICULARLY DESCRIBED AS FOLLOWS:

COMMENCING AT THE NORTHWEST CORNER OF SAID SE1/4 NW1/4;  
 THENCE ALONG THE WEST LINE OF THE SAID SE1/4 NW1/4 S 00° 00' 00" E FOR 1143.40 FEET;  
 THENCE N 87° 59' 54" E FOR 530.36 FEET LEAVING THE WEST LINE OF SAID SE1/4 NW1/4 TO A 5/8" REBAR AND THE POINT OF BEGINNING;  
 THENCE N 13° 04' 16" W FOR 193.28 FEET TO A 5/8" REBAR AND THE SOUTHERLY RIGHT OF WAY LINE OF BROWN LANE;  
 THENCE ALONG SAID RIGHT OF WAY LINE S 89° 20' 38" E FOR 195.38 FEET TO A 1/2" REBAR AND THE WESTERLY RIGHT OF WAY LINE OF NORTH REYNOLDS ROAD;  
 THENCE ALONG SAID RIGHT OF WAY LINE S 14° 49' 14" E FOR 194.54 FEET TO A 1/2" REBAR;  
 THENCE N 89° 25' 16" W FOR 201.43 FEET TO THE POINT OF BEGINNING.

**LEGEND**

	PROPERTY LINE
	EASEMENT
	SANITARY SEWER LINE
	OVERHEAD ELECTRIC LINE
	STORM DRAIN LINE
	EDGE OF ASPHALT
	CURB & GUTTER
	UTILITY POLE & GUY
	GAS METER
	TELEPHONE PEDESTAL
	SIGN
	CALCULATED POINT
	SHOWS FOUND SURVEY MARKER AS DESCRIBED

ISSUING AGENT: FIRST NATIONAL TITLE COMPANY  
 ISSUING OFFICE: 216 W. SEVIER STREET, BENTON, AR 72015  
 ISSUING OFFICE'S ALTA® REGISTRY ID: 1010363  
 COMMITMENT NO.: 102-230785-MH-1  
 ISSUING OFFICE FILE NO.: 102-230785-MH  
 PROPERTY ADDRESS: REYNOLDS ROAD, BRYANT, AR 72022  
 COMMITMENT DATE: AUGUST 14, 2023 AT 07:00 AM

**SCHEDULE B, PART II EXCEPTIONS**

THIS COMMITMENT DOES NOT REPUBLISH ANY COVENANT, CONDITION, RESTRICTION, OR LIMITATION CONTAINED IN ANY DOCUMENT REFERRED TO IN THIS COMMITMENT TO THE EXTENT THAT THE SPECIFIC COVENANT, CONDITION, RESTRICTION, OR LIMITATION VIOLATES STATE OR FEDERAL LAW BASED ON RACE, COLOR, RELIGION, SEX, SEXUAL ORIENTATION, GENDER IDENTITY, HANDICAP, FAMILIAL STATUS, OR NATIONAL ORIGIN. THE POLICY WILL NOT INSURE AGAINST LOSS OR DAMAGE RESULTING FROM THE TERMS AND PROVISIONS OF ANY LEASE OR EASEMENT IDENTIFIED IN SCHEDULE A, AND WILL INCLUDE THE FOLLOWING EXCEPTIONS UNLESS CLEARED TO THE SATISFACTION OF THE COMPANY:

- DEFECTS, LIENS, ENCUMBRANCES, ADVERSE CLAIMS OR OTHER MATTERS, IF ANY, CREATED, FIRST APPEARING IN THE PUBLIC RECORDS OR ATTACHING SUBSEQUENT TO THE EFFECTIVE DATE HEREOF BUT PRIOR TO THE DATE THE PROPOSED INSURED ACQUIRES FOR VALUE OF RECORD THE ESTATE OR INTEREST OR MORTGAGE THEREON COVERED BY THIS COMMITMENT.
- NOT SURVEY RELATED.
- ANY ENCROACHMENT, ENCUMBRANCE VIOLATION, VARIATION, OR ADVERSE CIRCUMSTANCE AFFECTING THE TITLE THAT WOULD BE DISCLOSED BY AN ACCURATE AND COMPLETE SURVEY OF THE LAND.
- SURVEY SHOWS BOUNDARY LINES AND IMPROVEMENTS.
- RIGHTS OR CLAIMS OF PARTIES IN POSSESSION NOT SHOWN BY THE PUBLIC RECORDS.
- NOT SURVEY RELATED.
- EASEMENTS, OR CLAIMS OF EASEMENTS, NOT SHOWN BY THE PUBLIC RECORDS.
- NONE TO SURVEYOR'S KNOWLEDGE.
- ANY LIEN, OR RIGHT TO A LIEN, FOR SERVICES, LABOR, OR MATERIAL HERETOFORE OR HEREAFTER FURNISHED, IMPOSED BY LAW AND NOT SHOWN BY THE PUBLIC RECORDS.
- NOT SURVEY RELATED.
- TAXES OR SPECIAL ASSESSMENTS WHICH ARE NOT SHOWN AS EXISTING LIENS BY PUBLIC RECORDS.
- NOT SURVEY RELATED.
- ANY PRIOR RESERVATION OR CONVEYANCE, TOGETHER WITH RELEASE OF DAMAGES OF MINERALS, OF EVERY KIND AND CHARACTER, INCLUDING, BUT NOT LIMITED TO, OIL, GAS, SAND AND GRAVEL IN, ON AND UNDER SUBJECT PROPERTY.
- NOT SURVEY RELATED.
- GENERAL TAXES FOR THE YEAR 2023, WHICH ARE NOT YET DUE AND PAYABLE, AND SUBSEQUENT YEARS, AND FUTURE INSTALMENTS OF THE FOLLOWING SPECIAL IMPROVEMENT DISTRICTS: SALINE WATERSHED REGIONAL WATER DISTRIBUTION DISTRICT; SALEM FIRE PROTECTION DISTRICT; BRYANT WATER & SEWER IMPROVEMENT DISTRICTS;
- NOT SURVEY RELATED.
- SUBJECT TO THE RIGHT OF CONTROLLED ACCESS TO AND FROM HIGHWAY 183.
- NOT SURVEY RELATED.
- UTILITY EASEMENTS AND BUILDING SET BACK LINES OVER AND ACROSS THE SUBJECT PROPERTY.
- EASEMENTS AND SETBACK LINES SHOWN ON THE SURVEY.
- RIGHT OF WAY EASEMENT IN FAVOR OF THE CITY OF BRYANT ARKANSAS FILED MAY 25, 1999 AS SALINE COUNTY DOCUMENT NO. 1999 28557 SHOWN ON THE SURVEY.
- RIGHT OF WAY EASEMENT IN FAVOR OF RELIANT ENERGY ARKANSAS FILED OCTOBER 4, 1999 AS SALINE COUNTY DOCUMENT NO. 1999 52869. SHOWN ON THE SURVEY.
- RIGHT OF WAY EASEMENT IN FAVOR OF BRYANT SEWER IMPROVEMENT DISTRICT NO. 1, FILED JULY 7, 1979 IN SALINE COUNTY MISCELLANEOUS BOOK 53 AT PAGE 754. SHOWN ON THE SURVEY.
- RIGHTS OF THE PUBLIC AND OTHERS ENTITLED THERETO IN AND TO USE OF THAT PORTION OF SUBJECT PROPERTY COMPRISING ANY ROAD, STREET, ALLEY, HIGHWAY, OR OTHER PUBLIC RIGHT OF WAY.
- NOT SURVEY RELATED.
- ANY INACCURACY IN THE AREA, SQUARE FOOTAGE, OR ACREAGE OF LAND DESCRIBED IN SCHEDULE A OR ATTACHED PLAT, IF ANY, THE COMPANY DOES NOT INSURE THE AREA, SQUARE FOOTAGE, OR ACREAGE OF THE LAND.
- NOT SURVEY RELATED.
- PLANNING AND/OR ZONING RULES, REGULATIONS AND/OR ORDINANCES ADOPTED BY THE SALINE COUNTY PLANNING BOARD, THE BRYANT PLANNING COMMISSION AND/OR THE CITY OF BRYANT, SALINE COUNTY, ARKANSAS AND/OR VIOLATIONS THEREOF.
- NOT SURVEY RELATED.
- MODIFIED EASEMENT BY AND BETWEEN ALCOA INC. TO BENTON PROPERTY INVESTMENTS, LLC DATED NOVEMBER 22, 2005 AND FILED NOVEMBER 23, 2005 AS SALINE COUNTY DOCUMENT NO. 2005 131400 AND SUBSEQUENT CONVEYANCES THEREOF. DOES NOT AFFECT PROPERTY.
- EASEMENT BY AND BETWEEN BRYANT SCHOOL DISTRICT NO. 25, ALCOA INC. AND REYNOLDS METALS COMPANY DATED NOVEMBER 2, 2004 AND FILED APRIL 15, 2005 AS SALINE COUNTY DOCUMENT NO. 2005 037378 AND SUBSEQUENT CONVEYANCES THEREOF. DOES NOT AFFECT PROPERTY.
- RIGHTS OR CLAIMS OF PARTIES IN POSSESSION AND EASEMENTS OR CLAIMS OF EASEMENTS NOT SHOWN BY THE PUBLIC RECORDS, BOUNDARY LINE DISPUTES, OVERLAPS, ENCROACHMENTS, AND ANY MATTERS NOT OF RECORD WHICH WOULD BE DISCLOSED BY AN ACCURATE SURVEY AND INSPECTION OF THE LAND.
- EASEMENTS, RIGHT OF WAY LINE AND SETBACK LINES SHOWN ON SURVEY.
- LOSS ARISING FROM SECURITY INTEREST EVIDENCED BY FINANCING STATEMENTS FILED OF RECORD UNDER THE ARKANSAS UNIFORM COMMERCIAL CODE, JUDGMENT LIENS OR OTHER LIENS OF RECORD IN ANY UNITED STATES DISTRICT COURT OR BANKRUPTCY COURT, IN THE STATE OF ARKANSAS, AS OF THE EFFECTIVE DATE HEREOF.
- NOT SURVEY RELATED.

**CERTIFICATE**  
 TO CHICAGO TITLE INSURANCE COMPANY, OBWAT HOLDINGS, LLC, FIRST NATIONAL TITLE COMPANY AN ARKANSAS CORPORATION, AND THEIR RESPECTIVE SUCCESSORS AND ASSIGNS: THIS IS TO CERTIFY THAT THIS MAP OR PLAT AND THE SURVEY ON WHICH IT IS BASED WERE MADE IN ACCORDANCE WITH THE 2016 MINIMUM STANDARD DETAIL REQUIREMENTS FOR ALTA/NSPS LAND TITLE SURVEYS, JOINTLY ESTABLISHED AND ADOPTED BY ALTA AND NSPS. THE FIELDWORK WAS COMPLETED ON SEPTEMBER 12, 2023.  
 DATE OF PLAT OR MAP: OCTOBER 3, 2023

JOHN R. POWNALL  
 ARKANSAS REGISTERED LAND SURVEYOR 1215

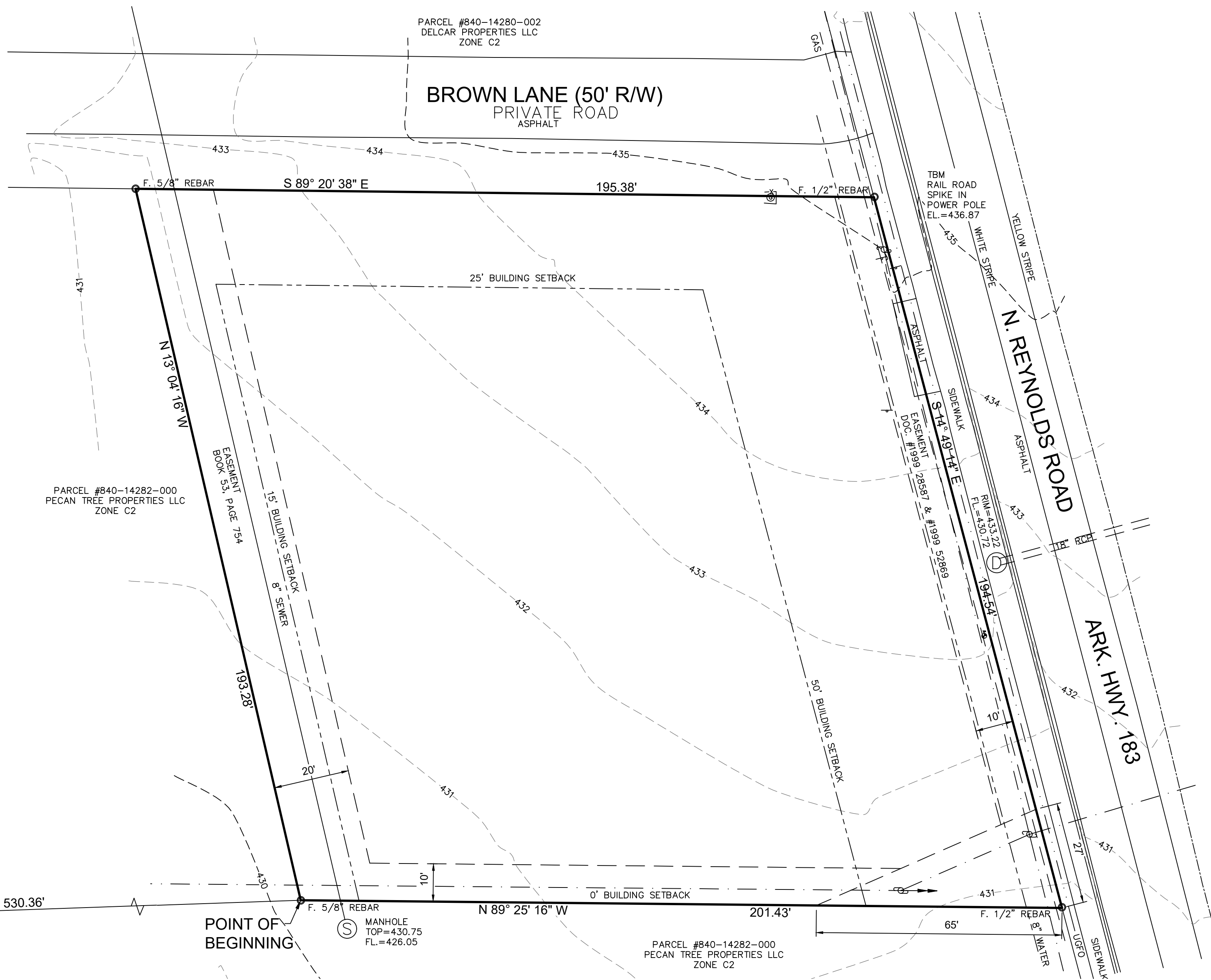

**POINT OF COMMENCEMENT**  
 NORTHWEST CORNER  
 SE1/4 NW1/4

**POINT OF BEGINNING**

- SURVEYOR'S NOTES**
- THE INFORMATION AND/OR ELEVATION OF EXISTING UTILITIES AS SHOWN ON THIS SURVEY IS BASED ON RECORDS OF EXISTING UTILITY COMPANIES AND WHERE POSSIBLE, MEASUREMENTS WERE TAKEN IN THE FIELD. THE INFORMATION IS NOT TO BE RELIED ON AS BEING COMPLETE. THE CONTRACTOR MUST CALL THE APPROPRIATE UTILITY COMPANY AT LEAST 48 HOURS IN ADVANCE BEFORE ANY EXCAVATION TO REQUEST EXACT FIELD LOCATION OF UTILITIES.
  - BASIS OF BEARINGS: ARKANSAS STATE PLANE, NORTH ZONE (ARDOT).
  - THIS PROPERTY IS NOT SHOWN IN THE 100 YEAR FLOOD PLAIN ON THE FLOOD INSURANCE RATE MAP COMMUNITY PANEL NUMBER 050308 0380 DATED JUNE 5, 2020.
  - THIS PROPERTY IS ZONED: C-2
  - THIS TRACT CONTAINS 37.231 SQ. FT. OR 0.855 ACRES, MORE OR LESS.
  - SETBACKS SHOWN ARE FOR C-2 ZONING.

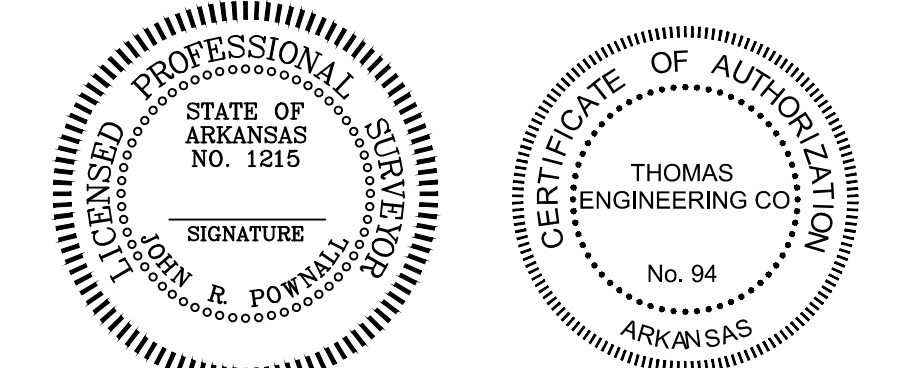
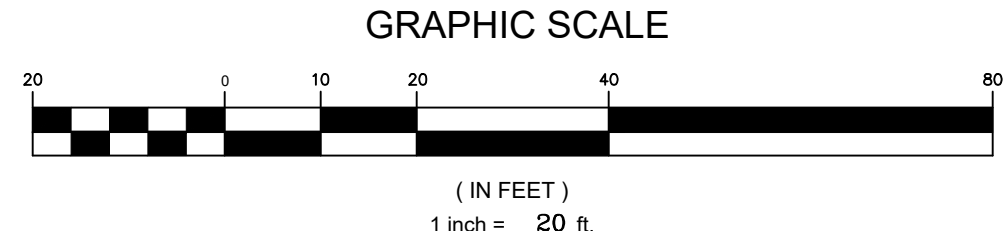

REVISION: REVISED 1/26/24 UPDATED LEGAL.

<b>TE</b> THOMAS ENGINEERING COMPANY	ALTA/NSPS SURVEY OF PART OF THE SE1/4 NW1/4, OF SECTION 27, T-1-S, R-14-W, SALINE COUNTY, ARKANSAS			
	APPROVED	DRAWN BY	DATE	SHEET NO.
3810 LOOKOUT ROAD, N. LITTLE ROCK, AR. 72116 TEL: 501-753-4463 FAX: 501-753-6814	MJC	10/3/23	V1	
SCALE 1" = 20'				

LITTLE CAESARS-BRYANT-23-0165.dwg

PLOTTED: 6/20/2024

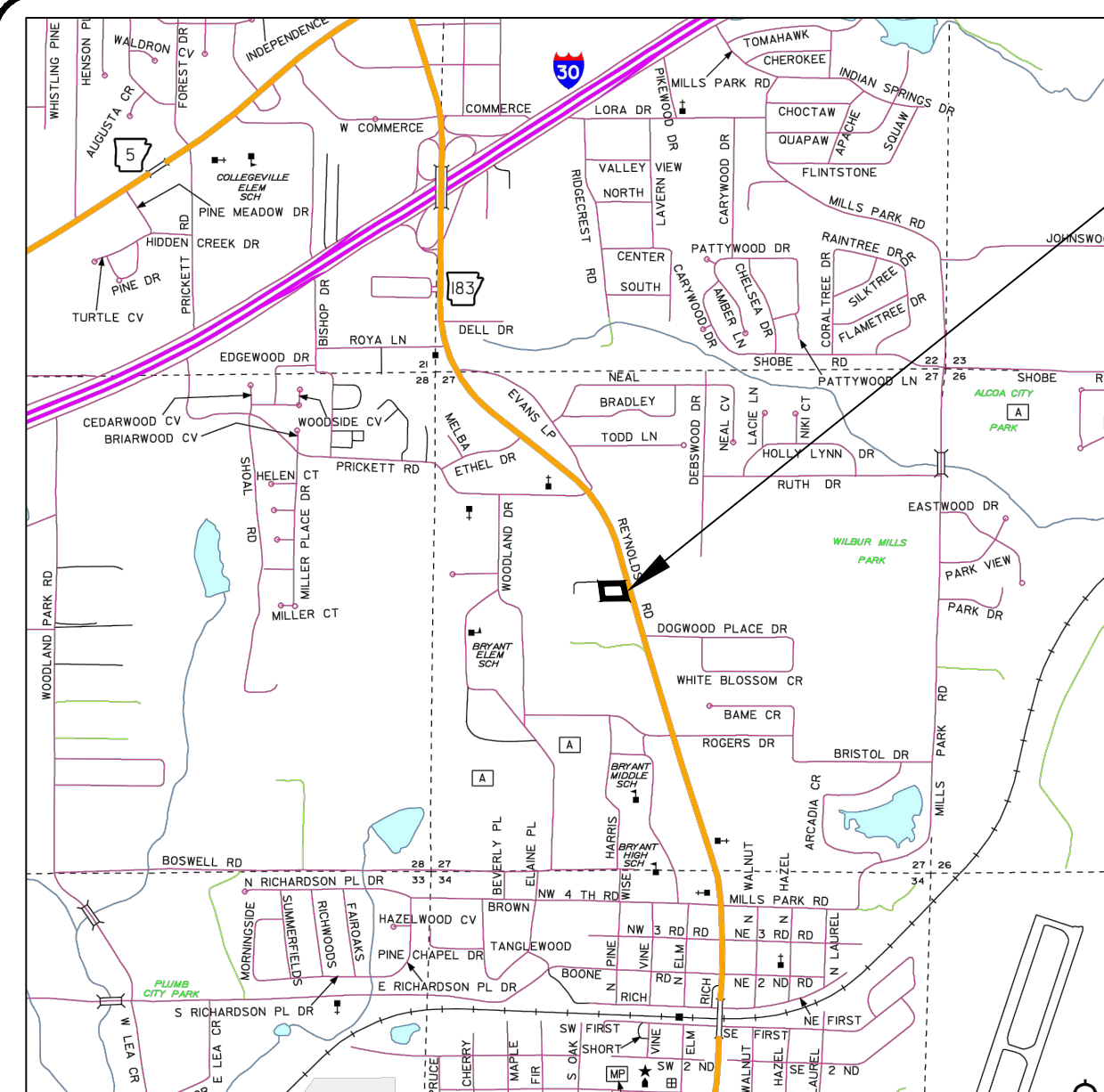

VICINITY MAP

THIS SITE



**SURVEY LEGAL DESCRIPTION:**

PART OF THE SE1/4 NW1/4 OF SECTION 27, TOWNSHIP 1 SOUTH, RANGE 14 WEST, IN THE CITY OF BRYANT, SALINE COUNTY, ARKANSAS, MORE PARTICULARLY DESCRIBED AS FOLLOWS:

COMMENCING AT THE NORTHWEST CORNER OF SAID SE1/4 NW1/4;  
 THENCE ALONG THE WEST LINE OF THE SAID SE1/4 NW1/4 S 00° 00' 00" E FOR 1143.40 FEET;  
 THENCE N 87° 59' 54" E FOR 530.36 FEET LEAVING THE WEST LINE OF SAID SE1/4 NW1/4 TO A 5/8" REBAR AND THE POINT OF BEGINNING;  
 THENCE N 13° 04' 16" W FOR 193.28 FEET TO A 5/8" REBAR AND THE SOUTHERLY RIGHT OF WAY LINE OF BROWN LANE;  
 THENCE ALONG SAID RIGHT OF WAY LINE S 89° 20' 38" E FOR 195.38 FEET TO A 1/2" REBAR AND THE WESTERLY RIGHT OF WAY LINE OF NORTH REYNOLDS ROAD;  
 THENCE ALONG SAID RIGHT OF WAY LINE S 14° 49' 14" E FOR 194.54 FEET TO A 1/2" REBAR;  
 THENCE N 89° 25' 16" W FOR 201.43 FEET TO THE POINT OF BEGINNING;

**LEGEND**

- PROPERTY LINE
  - EASEMENT
  - SANITARY SEWER LINE
  - OVERHEAD ELECTRIC LINE
  - STORM DRAIN LINE
  - EDGE OF ASPHALT
  - CURB & GUTTER
  - UTILITY POLE & GUY
  - GAS METER
  - TELEPHONE PEDESTAL
  - SIGN
  - CALCULATED POINT
  - SHOWS FOUND SURVEY MARKER AS DESCRIBED
- SHOWS HEAVY DUTY ASPHALT PAVEMENT (OR PAVING ALTERNATE - LIGHT DUTY CONC. PAVEMENT)
  - SHOWS LIGHT DUTY CONCRETE PAVEMENT EXCEPT AT DUMPSTER PAD
  - SHOWS CONCRETE SIDEWALK

- GENERAL NOTES:**
- ALL DIMENSIONS SHOWN ARE TO THE BACK OF CURB UNLESS OTHERWISE NOTED. RADII ARE 5 FEET UNLESS OTHERWISE INDICATED.
  - SEE ARCHITECTURAL PLANS FOR EXACT LOCATIONS AND DIMENSIONS OF PORCHES, RAMPS, SLOPED PAVING, TRUCK DOCKS, BUILDING UTILITY ENTRANCE LOCATIONS AND PRECISE BUILDING DIMENSIONS.
  - THE CONTRACTOR IS SPECIFICALLY CAUTIONED THAT THE LOCATION AND/OR ELEVATION OF EXISTING UTILITIES AS SHOWN ON THESE PLANS IS BASED ON RECORDS OF THE VARIOUS UTILITY COMPANIES AND WHERE POSSIBLE, MEASUREMENTS TAKEN IN THE FIELD. THE INFORMATION IS NOT TO BE RELIED ON AS BEING EXACT OR COMPLETE. THE CONTRACTOR MUST CALL THE APPROPRIATE UTILITY COMPANY AT LEAST 48 HOURS BEFORE ANY EXCAVATION TO REQUEST EXACT FIELD LOCATION OF UTILITIES. IT SHALL BE THE RESPONSIBILITY OF THE CONTRACTOR TO RELOCATE ALL EXISTING UTILITIES WHICH CONFLICT WITH THE PROPOSED IMPROVEMENTS SHOWN ON THE PLANS.
  - CONTRACTOR IS RESPONSIBLE FOR COMPLIANCE WITH O.S.H.A. AND ANY OTHER APPLICABLE LOCAL, STATE OR FEDERAL SAFETY REGULATIONS, INCLUDING THE USE OF TRENCH SHORING, ETC.
  - REPAIR, REPLACE OR EXTEND EXISTING DAMAGED OR MISSING CURB AND GUTTER, SIDEWALK, RAMPS OR CONCRETE APRONS ON SITE & WITHIN THE PUBLIC RIGHT-OF-WAY ADJACENT TO THE SITE. REMOVE ABANDONED DRIVEWAYS. ALL WORK WITHIN PUBLIC RIGHT-OF-WAY SHALL CONFORM TO CITY STANDARDS AND ADA GUIDELINES.
  - CONTACT BRYANT STREET DEPARTMENT FOR INSPECTIONS OF ANY WORK IN PUBLIC RIGHT-OF-WAY PRIOR TO PLACEMENT OF CONCRETE OR ASPHALT OR FOR CLARIFICATION OF REQUIREMENTS PRIOR TO COMMENCING WORK. FAILURE TO DO SO CAN RESULT IN REMOVAL OF ANY IMPROPERLY PLACED CONCRETE OR ASPHALT AT THE EXPENSE OF THE CONTRACTOR.
  - CONTACT BRYANT FIRE DEPARTMENT FOR LOCATION AND REQUIREMENTS FOR FIRE LANE STRIPING ON SITE BEFORE APPLICATION. FIRE LANES WILL BE 4" WHITE LETTERS ON 6" RED TRAFFIC PAINT AT 15' INTERVALS.

**SITE PLAN NOTES**

- SITE CONTAINS A PROPOSED DRIVE THRU RESTAURANT.
- BASIS OF BEARINGS: GPS GRID NORTH.
- THE PROPERTY IS NOT SHOWN IN THE 100 YEAR FLOOD PLAIN ON THE FLOOD INSURANCE RATE MAP COMMUNITY PANEL NUMBER 050308 0380E, DATED 6/05/20.
- THIS PROPERTY IS ZONED C-2.
- ALL ABUTTING PROPERTIES ARE ZONED C-2.
- THIS TRACT CONTAINS 37,231 S.F. OR 0.855 ACRES, MORE OR LESS.
- SETBACKS FOR C-2 ZONING ON HWY 183 ARE:  
 50' FRONT  
 0' SIDE OR 25' ALONG STREET OR RESIDENTIAL  
 15' REAR OR 55' ABUTTING RESIDENTIAL
- BUILDING TO LOT COVERAGE 5.0% (35% MAX.).  
 IMPERVIOUS SURFACE AREA TO LOT COVERAGE 65%.

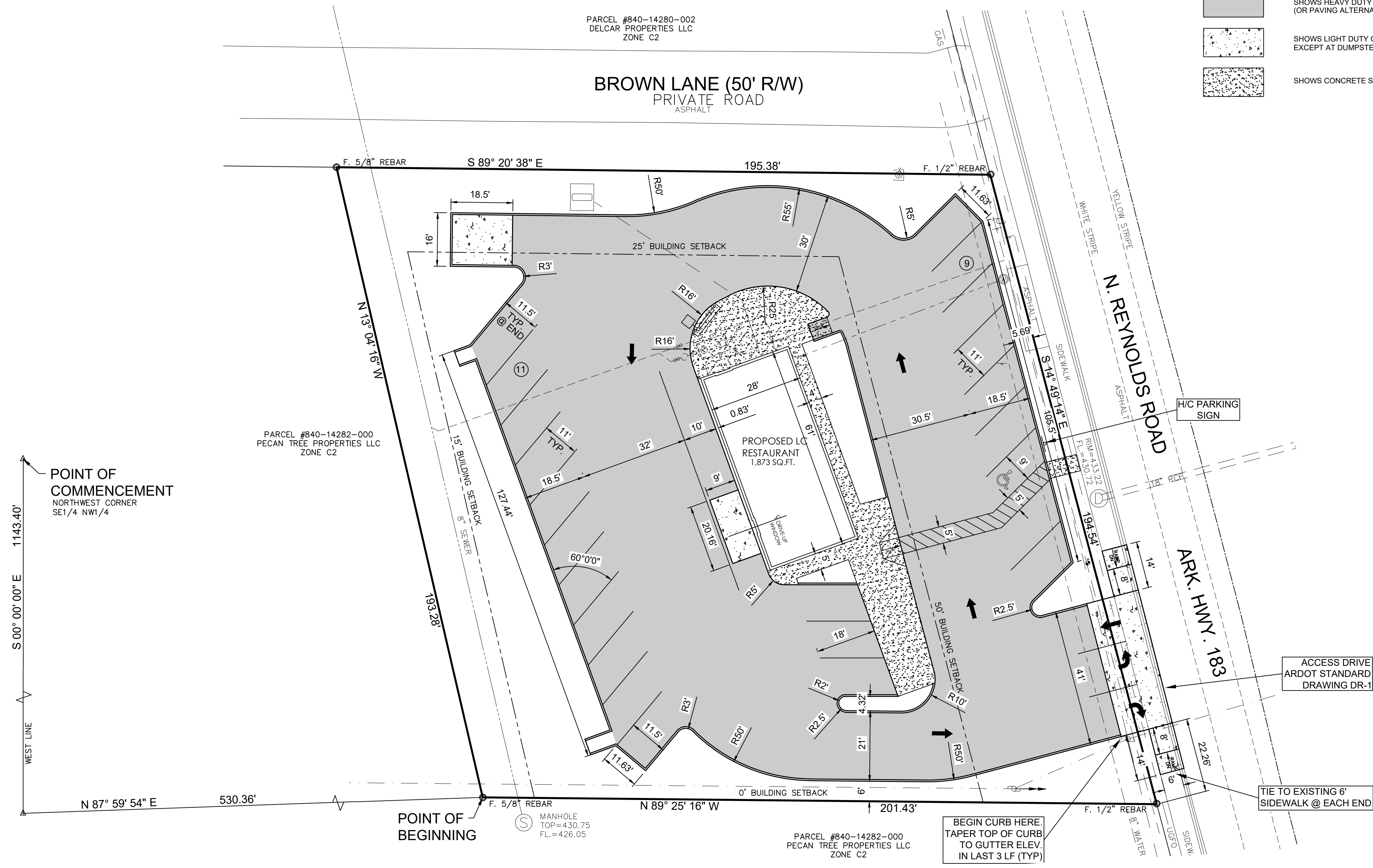

**PARKING**

REGULAR	19 SPACES
ACCESSIBLE	1 SPACES
TOTAL	20 SPACES
REQUIRED	7 SPACES (1 SPACE/300 SF OCCUPIED SPACE)

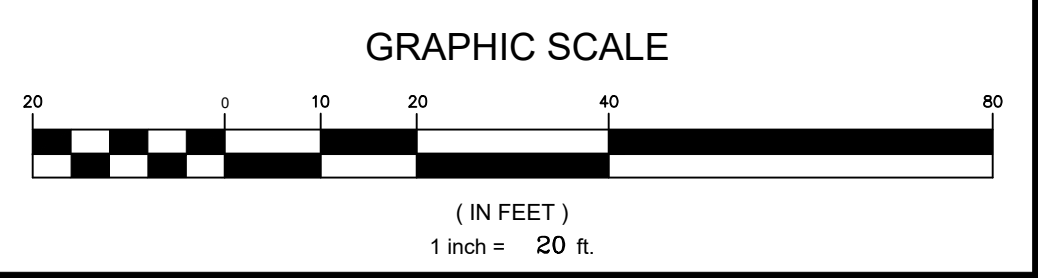
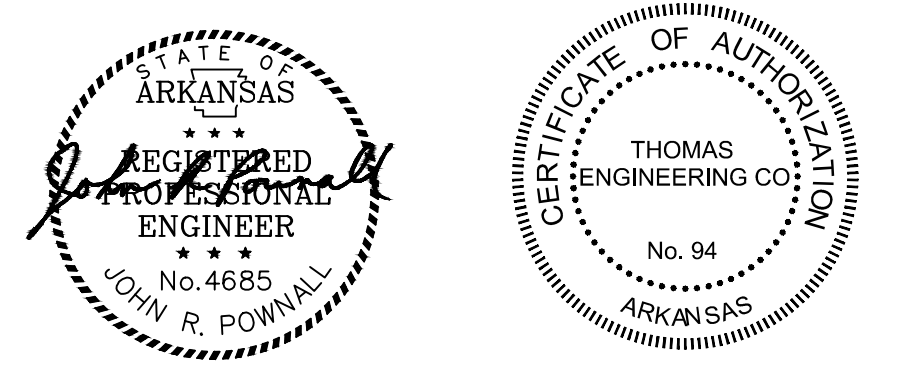

**THOMAS ENGINEERING COMPANY**

3810 LOOKOUT ROAD, N. LITTLE ROCK, AR. 72116  
 TEL: 501-753-4463 FAX: 501-753-6814

**SITE PLAN**  
**LITTLE CAESARS**  
**BRYANT, ARKANSAS**

APPROVED	DRAWN BY	DATE	SHEET NO.
	JRP	6/11/24	C2
SCALE			
1" = 20'			

PRELIMINARY – NOT FOR CONSTRUCTION

LITTLE CAESARS-BRYANT-23-0165.dwg

PLOTTED: 6/20/2024

LITTLE CAESARS-BRYANT-23-0165.dwg

PLOTTED: 6/20/2024

GRADING PLAN  
GENERAL NOTES

1. THE GENERAL CONTRACTOR SHALL TAKE ALL PRECAUTIONS NECESSARY TO AVOID PROPERTY DAMAGE TO ADJACENT PROPERTIES DURING THE CONSTRUCTION PHASES OF THIS PROJECT. THE CONTRACTOR WILL BE HELD SOLELY RESPONSIBLE FOR ANY DAMAGES TO THE ADJACENT PROPERTIES OCCURRING DURING THE CONSTRUCTION PHASES OF THIS PROJECT.
2. WARRANTY/DISCLAIMER. THE DESIGNS REPRESENTED IN THESE PLANS ARE IN ACCORDANCE WITH ESTABLISHED PRACTICES OF CIVIL ENGINEERING FOR THE DESIGN FUNCTIONS AND USES INTENDED AT THIS TIME. HOWEVER, NEITHER THOMAS ENGINEERING COMPANY, INC., NOR ITS PERSONNEL CAN OR DO WARRANTY THESE DESIGNS OR PLANS AS CONSTRUCTED EXCEPT IN THE SPECIFIC CASES WHERE THOMAS ENGINEERING COMPANY PERSONNEL INSPECT AND CONTROL THE PHYSICAL CONSTRUCTION ON A CONTEMPORARY BASIS AT THE SITE.
3. SAFETY NOTICE TO CONTRACTOR. IN ACCORDANCE WITH GENERALLY ACCEPTED CONSTRUCTION PRACTICES, THE CONTRACTOR WILL BE SOLELY AND COMPLETELY RESPONSIBLE FOR CONDITIONS OF THE JOB SITE, INCLUDING SAFETY OF ALL PERSONS AND PROPERTY DURING PERFORMANCE OF THE WORK. THIS REQUIREMENT WILL APPLY CONTINUOUSLY AND NOT BE LIMITED TO NORMAL WORKING HOURS. THE DUTY OF THE ENGINEER OR OWNER TO CONDUCT CONSTRUCTION REVIEW OF THE CONTRACTOR'S PERFORMANCE IS NOT INTENDED TO INCLUDE REVIEW OF THE ADEQUACY OF THE CONTRACTOR'S SAFETY MEASURES, IN, ON OR NEAR THE CONSTRUCTION SITE.
4. ENGINEER'S NOTICE TO CONTRACTOR. THE CONTRACTOR IS SPECIFICALLY CAUTIONED THAT THE LOCATION AND/OR ELEVATION OF EXISTING UTILITIES AS SHOWN ON THESE PLANS IS BASED ON RECORDS OF THE VARIOUS UTILITY COMPANIES AND, WHERE POSSIBLE, MEASUREMENTS TAKEN IN THE FIELD. THE INFORMATION IS NOT TO BE RELIED ON AS BEING EXACT OR COMPLETE. THE CONTRACTOR MUST CALL THE APPROPRIATE UTILITY COMPANY AT LEAST 48 HOURS BEFORE ANY EXCAVATION TO REQUEST EXACT FIELD LOCATIONS OF UTILITIES. IT SHALL BE THE RESPONSIBILITY OF THE CONTRACTOR TO RELOCATE ALL EXISTING UTILITIES WHICH CONFLICT WITH THE PROPOSED IMPROVEMENTS SHOWN ON THE PLANS.
5. SEE ARCHITECTURAL PLANS FOR DETAILS ON CONCRETE RAMPS AND SIDEWALKS ATTACHED TO BUILDINGS.
6. FINISHED GRADE CONTOURS ARE INDICATED ALONG TOP OF COMPLETED STRUCTURES, TOP OF PAVEMENT AND GUTTER LINE OF CURB, UNLESS OTHERWISE SHOWN. FOR ROUGH GRADING, CONTRACTOR SHALL ALLOW FOR DEPTHS OF TOPSOIL AND CONCRETE STRUCTURES. FOR FINISH GRADING, CONTRACTOR SHALL INSTALL TOPSOIL AND CONCRETE STRUCTURES TO FINISHED GRADE AS INDICATED ON THIS SHEET.
7. THE GENERAL CONTRACTOR SHALL FURNISH "AS-BUILT" DRAWINGS AT END OF PROJECT.
8. ALL STORM DRAIN LINES AND UTILITY LINES UNDER THE PAVEMENT SHALL BE BACK FILLED WITH CRUSHED STONE.
9. PLACE A 4" MINIMUM DEPTH OF TOPSOIL OVER ALL LAWN AND LANDSCAPE AREAS.
10. REFER TO LANDSCAPE PLAN FOR PERMANENT TURF SOD AND SEEDING AREAS.
11. PROVIDE TEMPORARY SEEDING AND EROSION CONTROL PER STATE AND LOCAL CODES.

LEGEND

- 100 - - - - - EXISTING CONTOURS
- 101 - - - - - PROPOSED CONTOURS
- 400.0 o PROPOSED SPOT ELEVATION GUTTER
- 400.0 T o PROPOSED SPOT ELEVATION TOP OF CURB
- 400.00 x EXISTING SPOT ELEVATION
- ⇒ DRAINAGE ARROW

NOTE: SPOT ELEVATIONS FINISHED GRADE UNLESS OTHERWISE SHOWN.

LEGEND

- PROPERTY LINE
- EASEMENT
- SANITARY SEWER LINE
- OVERHEAD ELECTRIC LINE
- STORM DRAIN LINE
- EDGE OF ASPHALT
- CURB & GUTTER
- UTILITY POLE & GUY
- GAS METER
- TELEPHONE PEDESTAL
- SIGN
- CALCULATED POINT
- o SHOWS FOUND SURVEY MARKER AS DESCRIBED

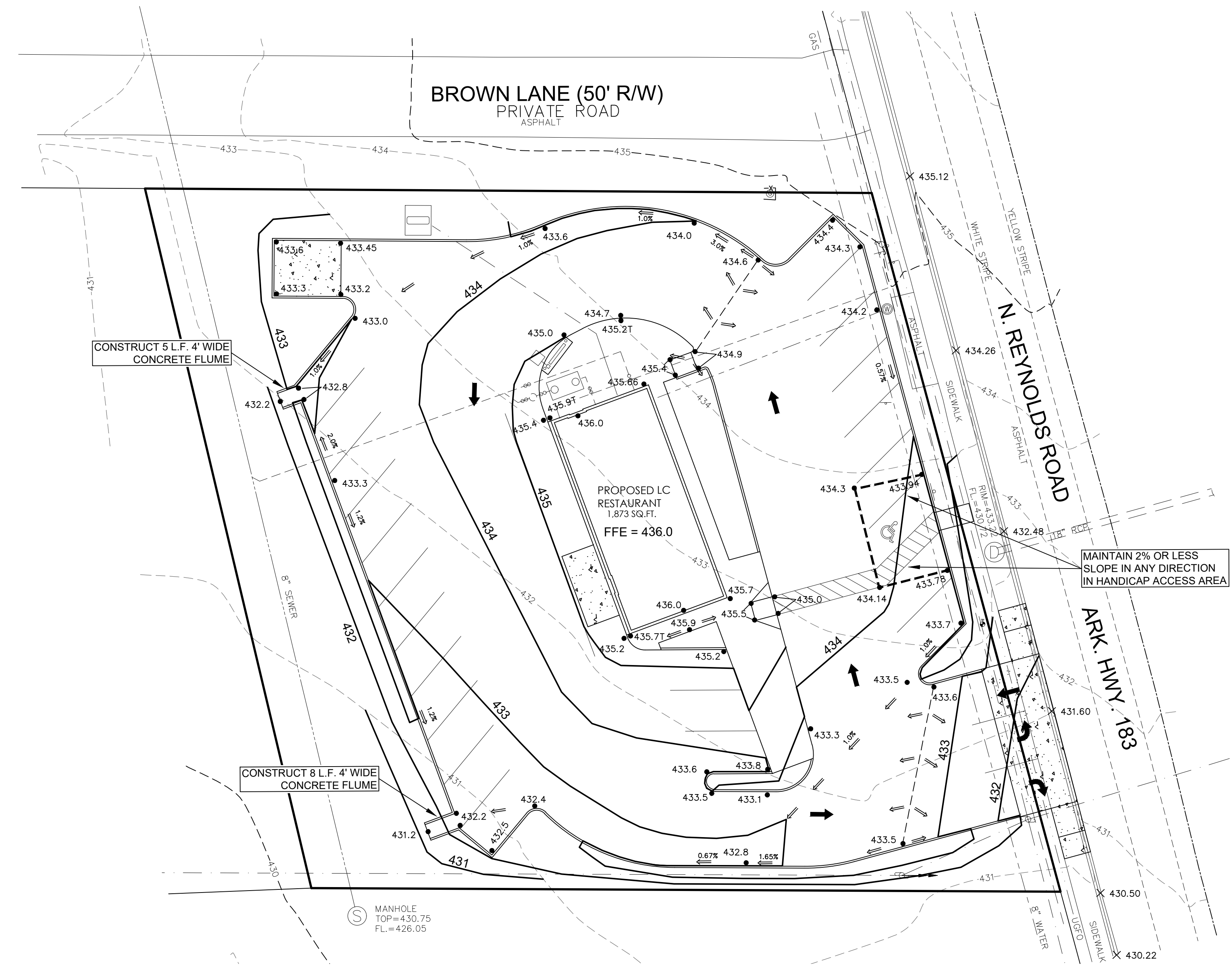

PRELIMINARY – NOT FOR CONSTRUCTION

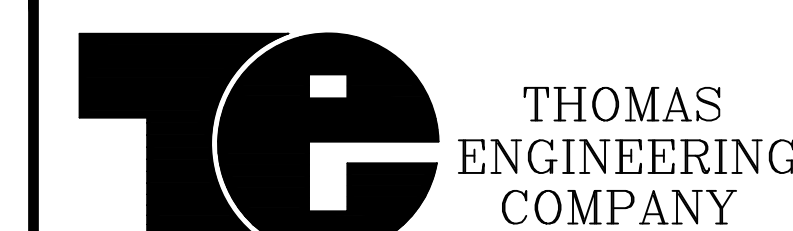
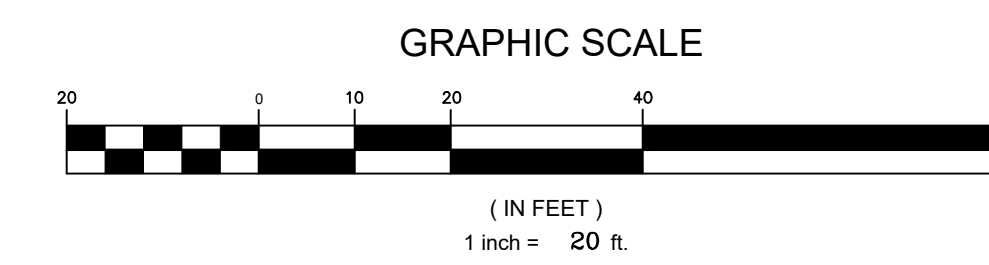

THOMAS ENGINEERING COMPANY  
 3810 LOOKOUT ROAD, N. LITTLE ROCK, AR. 72116  
 TEL: 501-753-4463 FAX: 501-753-6814

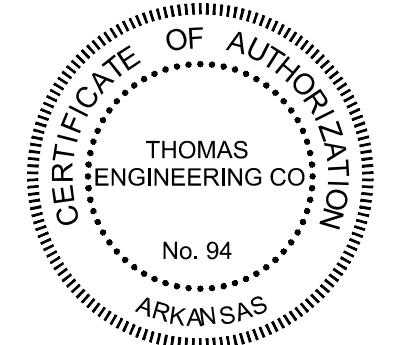
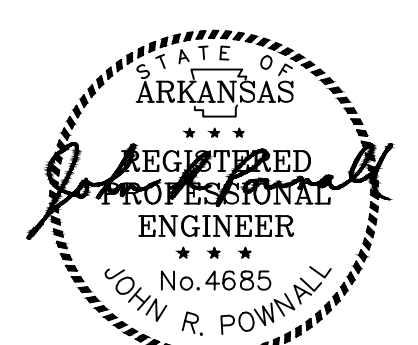

GRADING PLAN  
 LITTLE CAESARS  
 BRYANT, ARKANSAS

APPROVED	DRAWN BY	DATE	SHEET NO.
	JRP	6/11/24	C3
SCALE			
1" = 20'			

LITTLE CAESARS-BRYANT-23-0165.dwg

PLOTTED: 6/20/2024

UTILITY NOTES:

1. CONTRACTOR SHALL LOCATE ALL EXISTING UTILITIES IN ACCORDANCE WITH THE ARKANSAS UNDERGROUND FACILITIES DAMAGE PREVENTION ACT. THIS LAW REQUIRES THAT THE CONTRACTOR MAKE A TELEPHONE CALL TO THE ARKANSAS ONE-CALL SYSTEM AT 1-800-482-8998 AT LEAST TWO (2) WORKING DAYS PRIOR TO EXCAVATING TO ENSURE THAT ANY EXISTING UTILITIES CAN BE LOCATED.
2. CONTRACTOR TO UNCOVER AND MARK UTILITY LINES BEFORE CONSTRUCTION.
3. CONTRACTOR SHALL BEAR ALL RESPONSIBILITY AND COST OF REPAIR OR REPLACEMENT OF EXISTING UTILITIES DAMAGED OR INTERRUPTED AS A RESULT OF THIS CONSTRUCTION.
4. CONTRACTOR SHALL NOTIFY THE PROJECT ENGINEER AND THE OWNER OF ANY DAMAGED OR INTERRUPTED UTILITIES IMMEDIATELY.
5. ALL SEWER MAINS, SERVICES AND APPURTENANCES SHALL BE INSTALLED IN ACCORDANCE TO THE BRYANT WATER WORKS SPECIFICATIONS, THE ARKANSAS DEPARTMENT OF HEALTH AND THE ARKANSAS STATE PLUMBING CODE.
6. ALL WATER LINES SERVICES AND APPURTENANCES SHALL BE INSTALLED IN ACCORDANCE TO THE BRYANT WATER WORKS REQUIREMENTS AND THE ARKANSAS STATE PLUMBING CODE.
7. SEE PLUMBING PLANS FOR EXACT LOCATION OF UTILITY ENTRANCES TO THE BUILDING.
8. IN AREAS WHERE UTILITIES ARE INSTALLED UNDER NEW ASPHALT PAVEMENT, REFER TO DETAIL "PIPE TRENCH & BACKFILL SECTION DETAIL UNDER NEW PAVEMENT."

ELECTRIC UTILITY NOTES:

1. CONTRACTOR SHALL VERIFY THE SIZE AND LOCATION OF TRANSFORMER PAD AND PROVIDE THE MINIMUM SIZED PAD REQUIRED BY ENTERGY.
2. THE CONTRACTOR SHALL PAY ENTRY FOR ALL SWITCHGEAR, CONNECTIONS, UNDERGROUND 3 PHASE PRIMARY WIRE, 3 PHASE PAD MOUNTED TRANSFORMER AND SECONDARY UNDERGROUND SERVICE WIRE.

SANITARY SEWER GENERAL NOTES

1. 4" SERVICE LINES AND STUBS SHALL BE LAID ON MINIMUM 1% SLOPE.
2. MAINTAIN 10' MINIMUM CLEARANCE BETWEEN WATER AND SEWER LINES.
3. PVC PIPE SHALL HAVE ASTM C33 #7 STONE BEDDING 6" ON ALL SIDES.
4. SEWER SERVICE PIPE MATERIAL SHALL CONFORM TO ONE OF THE FOLLOWING STANDARDS: ASTM D 2665, SCHEDULE 40 DWV OR ASTM D3034, PVC SEWER PIPE, SDR-26

WATER NOTES:

1. ALL PIPES TO HAVE A MINIMUM OF 3' OF COVER.
2. ALL NON-METALLIC MAINS SHALL HAVE A 12 GA. COPPER TRACING WIRE.
3. ALL P.V.C. PIPE SHALL BE CLASS 250.
4. MAINTAIN 18" VERTICAL SEPARATION BETWEEN WATER/SEWER CROSSINGS.
5. MAINTAIN 5' HORIZONTAL SEPARATION BETWEEN PARALLEL UTILITIES.
6. CONTRACTOR TO PAY FOR INSTALLATION OF DOMESTIC AND IRRIGATION METERS.

WATER LINE PIPE MATERIALS:

1. DUCTILE IRON PIPE SHALL CONFORM TO ANSI A21.51 (AWWA C151) AND SHALL HAVE A CEMENT MORTAR LINING AND SEAL COAT CONFORMING TO ANSI A21.4 (AWWA C104) AND NSF 61. JOINTS SHALL CONFORM TO ANSI A21.11 (AWWA C111) AND MAY BE MECHANICAL JOINT OR PUSH-ON JOINT UNLESS OTHERWISE SPECIFIED. GASKETS SHALL BE MANUFACTURED IN THE UNITED STATES AND/OR COSTA RICA. THE MINIMUM CLASS OF D.I. PIPE SHALL BE THICKNESS CLASS 50 UNLESS OTHERWISE SPECIFIED. ALL DUCTILE IRON SHALL BE ENCASED IN POLYETHYLENE (POLYWRAPPED) UPON INSTALLATION (SEE SECTION 21 OF THE CAW CONSTRUCTION SPECIFICATIONS FOR SPECIFICS). ALL DUCTILE IRON MAINS SHALL END WITH A FULL JOINT OF MECHANICAL JOINT PIPE WITH A MECHANICAL JOINT PLUG AND ANCHOR COLLAR.
2. PVC WATER MAIN PIPE SHALL CONFORM TO AWWA C900, DR18, PVC PRESSURE PIPE AND FABRICATED FITTINGS 4" THROUGH 12". PVC WATER PIPE SHALL HAVE INTEGRAL BELL JOINTS WITH ELASTOMETRIC GASKETS THAT CONFORM TO ASTM 3212 AND ASTM F477.
3. WATER SERVICE PIPE SHALL CONFORM TO AWWA C904, DR9, CROSS-LINKED POLYETHYLENE (PEX), SDR9, MINIMUM PRESSURE CLASS 160, PRESSURE PIPE AND TUBING, 1/2 IN. THROUGH 3 IN, FOR WATER SERVICE.



LEGEND

- PROPERTY LINE
- EASEMENT
- SANITARY SEWER LINE
- OVERHEAD ELECTRIC LINE
- STORM DRAIN LINE
- EDGE OF ASPHALT
- CURB & GUTTER
- UTILITY POLE & GUY
- GAS METER
- TELEPHONE PEDESTAL
- SIGN
- CALCULATED POINT
- SHOWS FOUND SURVEY MARKER AS DESCRIBED

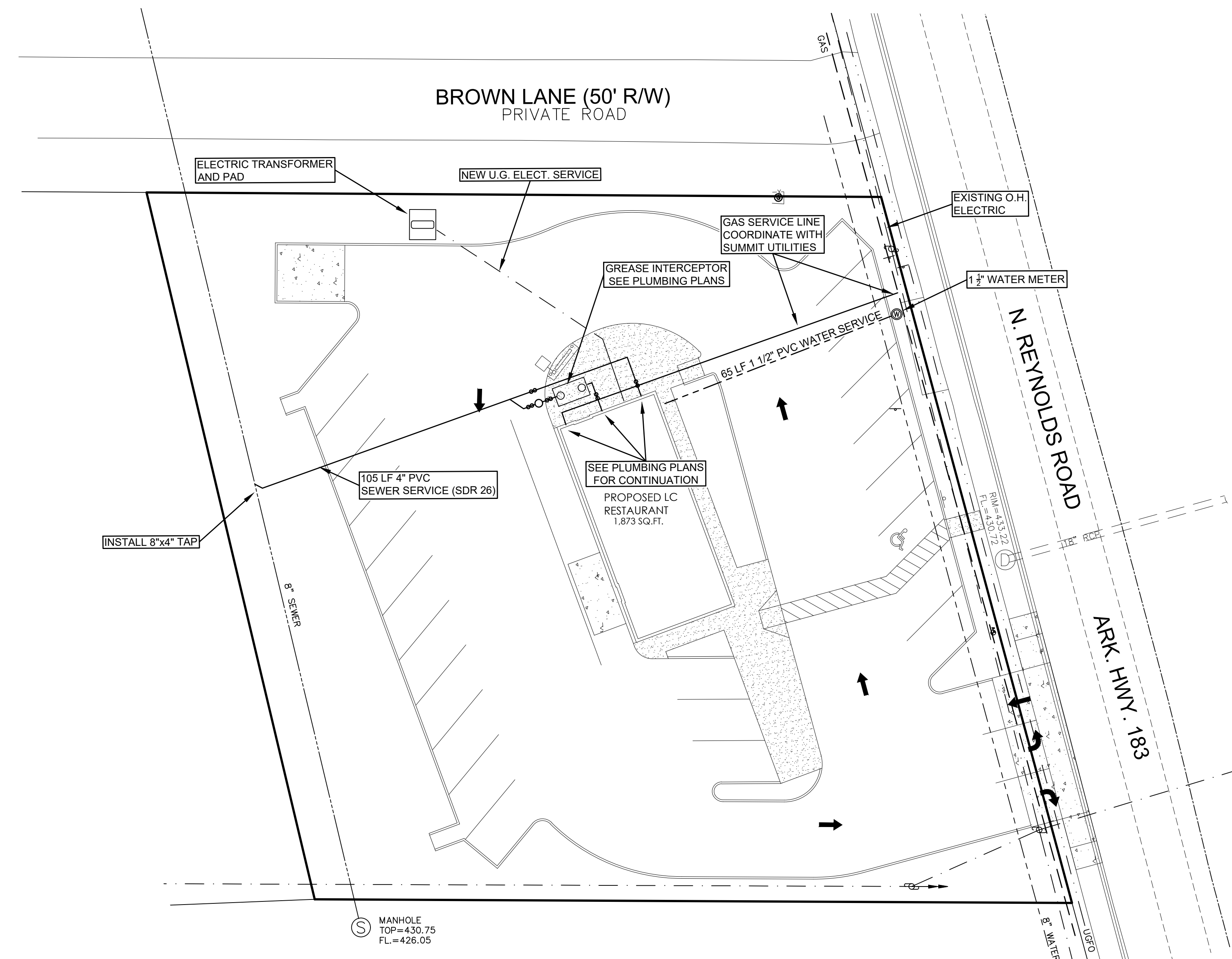

PRELIMINARY – NOT FOR CONSTRUCTION

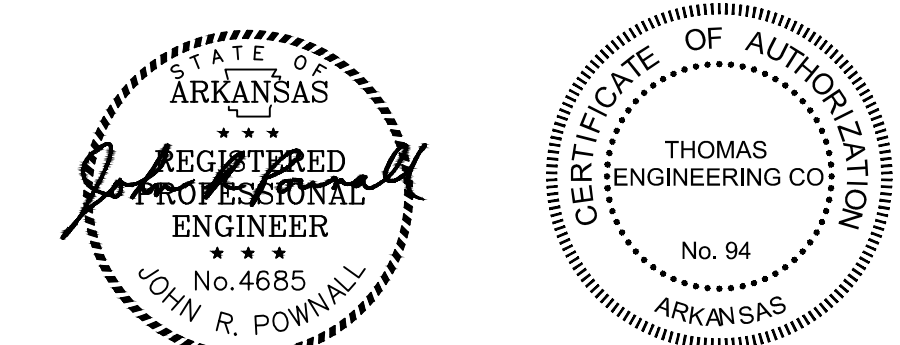
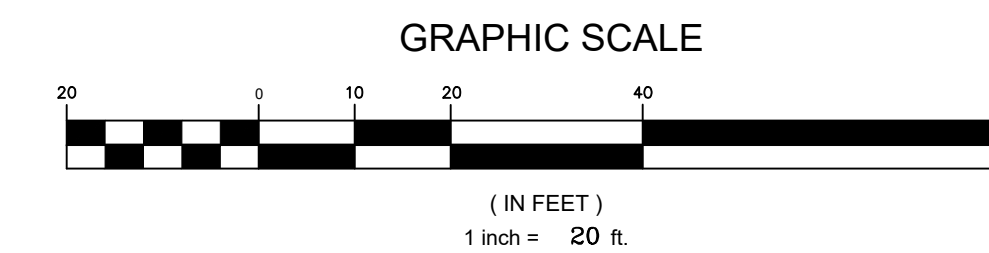

**THOMAS ENGINEERING COMPANY**  
 3810 LOOKOUT ROAD, N. LITTLE ROCK, AR. 72116  
 TEL: 501-753-4463 FAX: 501-753-6814

**UTILITY PLAN**  
**LITTLE CAESARS**  
**BRYANT, ARKANSAS**

APPROVED	DRAWN BY	DATE	SHEET NO.
	JRP	6/11/24	C4
SCALE			
1" = 20'			

**SEQUENCE OF CONSTRUCTION**

1. INSTALL CONSTRUCTION ENTRANCE AND PERIMETER SILT FENCE. CONTRACTOR SHALL INSTALL WHATEVER DIVERSIONS/SNALES ARE NECESSARY TO ROUTE ALL SEDIMENT LADEN WATER TO THE PROPOSED SILT FENCE LOCATIONS.
2. CLEAR SITE AND REMOVE ALL DEMOLITION DEBRIS.
3. BEGIN GRADING OPERATION FOR SITE.
4. BEGIN UTILITY CONSTRUCTION. MAINTAIN ANY DIVERSIONS TO ROUTE ALL UPSTREAM WATER AWAY FROM THE EXISTING STREETS THROUGHOUT CONSTRUCTION.
5. INSTALL CURB AND GUTTER AND SIDEWALKS.
6. FINE GRADE ENTIRE SITE, AND COMPLETE PAVING OPERATIONS.
7. INSTALL SEEDNG, VEGETATION, AND PROCEED WITH FINAL SITE STABILIZATION. WATER ALL GRASSED AREAS.
8. INSPECT AND RESOD ALL DISTURBED AREAS AS NECESSARY. UPON FINAL SITE STABILIZATION, CLEAN SILT FROM BEHIND ALL SEDIMENT FENCES AND REMOVE ALL TEMPORARY EROSION CONTROL DEVICES.

**EROSION CONTROL NOTES:**

1. SEDIMENT CONTROL MEASURES MUST BE INSPECTED AND MAINTAINED REGULARLY IN ORDER TO INSURE THAT THE INTENDED PURPOSES ARE ACCOMPLISHED.
2. ALL DISTURBED AREAS NOT INTENDED FOR PAVING SHALL BE SEEDED OR SOODED AS PER SPECIFICATIONS.
3. STABILIZATION REQUIREMENTS: (NOT NECESSARILY VEGETATION) ALL PERIMETER CONTROLS ARE TO BE STABILIZED WITHIN 7 DAYS OF INSTALLATION. ALL OTHER DISTURBED AREAS ARE TO BE STABILIZED WITHIN 14 DAYS.
4. TEMPORARY SEDIMENT CONTROL MEASURES SHALL BE MAINTAINED UNTIL ALL CONTRIBUTING AREAS ARE GRADED AND STABILIZED.
5. EXCAVATED EARTH SHALL BE PILED ON THE HIGH SIDE OF EXCAVATIONS.
6. EROSION CONTROL MEASURES WILL BE MAINTAINED AT ALL TIMES. IF FULL IMPLEMENTATION OF THE APPROVED PLAN DOES NOT PROVIDE FOR EFFECTIVE EROSION CONTROL, ADDITIONAL EROSION AND SEDIMENT CONTROL MEASURES SHALL BE IMPLEMENTED TO CONTROL OR TREAT THE SEDIMENT SOURCE.
7. THE ESCAPE OF SEDIMENT FROM THE SITE SHALL BE PREVENTED BY THE INSTALLATION OF EROSION AND SEDIMENT CONTROL MEASURES AND PRACTICES PRIOR TO, OR CONCURRENT WITH, LAND-DISTURBING ACTIVITIES.

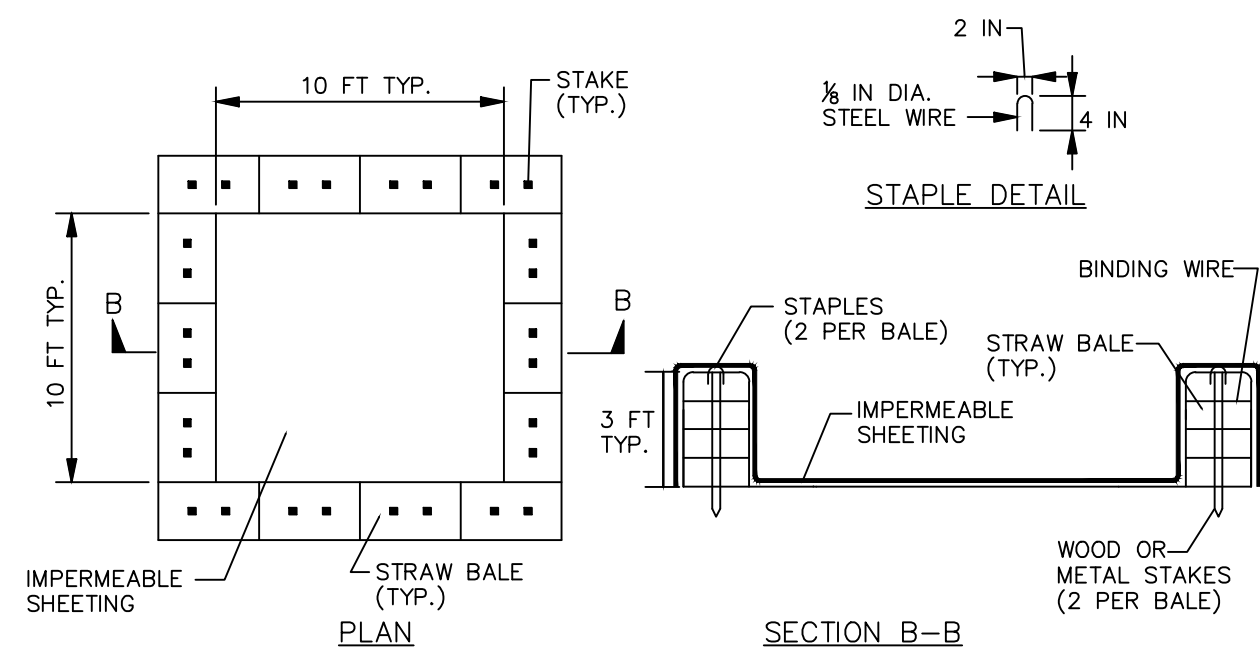

NOTE: CAN BE TWO STACKED BALES OR PARTIALLY EXCAVATED TO REACH 3 FT DEPTH

**WASHOUT STRUCTURE WITH STRAW BALES**

**CONSTRUCTION SPECIFICATIONS**

1. LOCATE WASHOUT STRUCTURE A MINIMUM OF 50 FEET AWAY FROM OPEN CHANNELS, STORM DRAIN INLETS, SENSITIVE AREAS, WETLANDS, BUFFERS AND WATER COURSES AND AWAY FROM CONSTRUCTION TRAFFIC.
2. SIZE WASHOUT STRUCTURE FOR VOLUME NECESSARY TO CONTAIN WASH WATER AND SOLIDS AND MAINTAIN AT LEAST 4 INCHES OF FREEBOARD. TYPICAL DIMENSIONS ARE 10 FEET X 10 FEET X 3 FEET DEEP.
3. PREPARE SOIL BASE FREE OF ROCKS OR OTHER DEBRIS THAT MAY CAUSE TEARS OR HOLES IN THE LINER. FOR LINER, USE 10 MIL OR THICKER UV RESISTANT, IMPERMEABLE SHEETING, FREE OF HOLES AND TEARS OR OTHER DEFECTS THAT COMPROMISE IMPERMEABILITY OF THE MATERIAL.
4. PROVIDE A SIGN FOR THE WASHOUT IN CLOSE PROXIMITY TO THE FACILITY.
5. KEEP CONCRETE WASHOUT STRUCTURE WATER TIGHT. REPLACE IMPERMEABLE LINER IF DAMAGED (E.G., RIPPED OR PUNCTURED). EMPTY OR REPLACE WASHOUT STRUCTURE THAT IS 75 PERCENT FULL, AND DISPOSE OF ACCUMULATED MATERIAL PROPERLY. DO NOT REUSE PLASTIC LINER. WET-VACUUM STORED LIQUIDS THAT HAVE NOT EVAPORATED AND DISPOSE OF IN AN APPROVED MANNER. PRIOR TO FORECASTED RAINSTORMS, REMOVE LIQUIDS OR COVER STRUCTURE TO PREVENT OVERFLOWS. REMOVE HARDENED SOLIDS, WHOLE OR BROKEN UP, FOR DISPOSAL OR RECYCLING. MAINTAIN RUNOFF DIVERSION AROUND EXCAVATED WASHOUT STRUCTURE UNTIL STRUCTURE IS REMOVED.

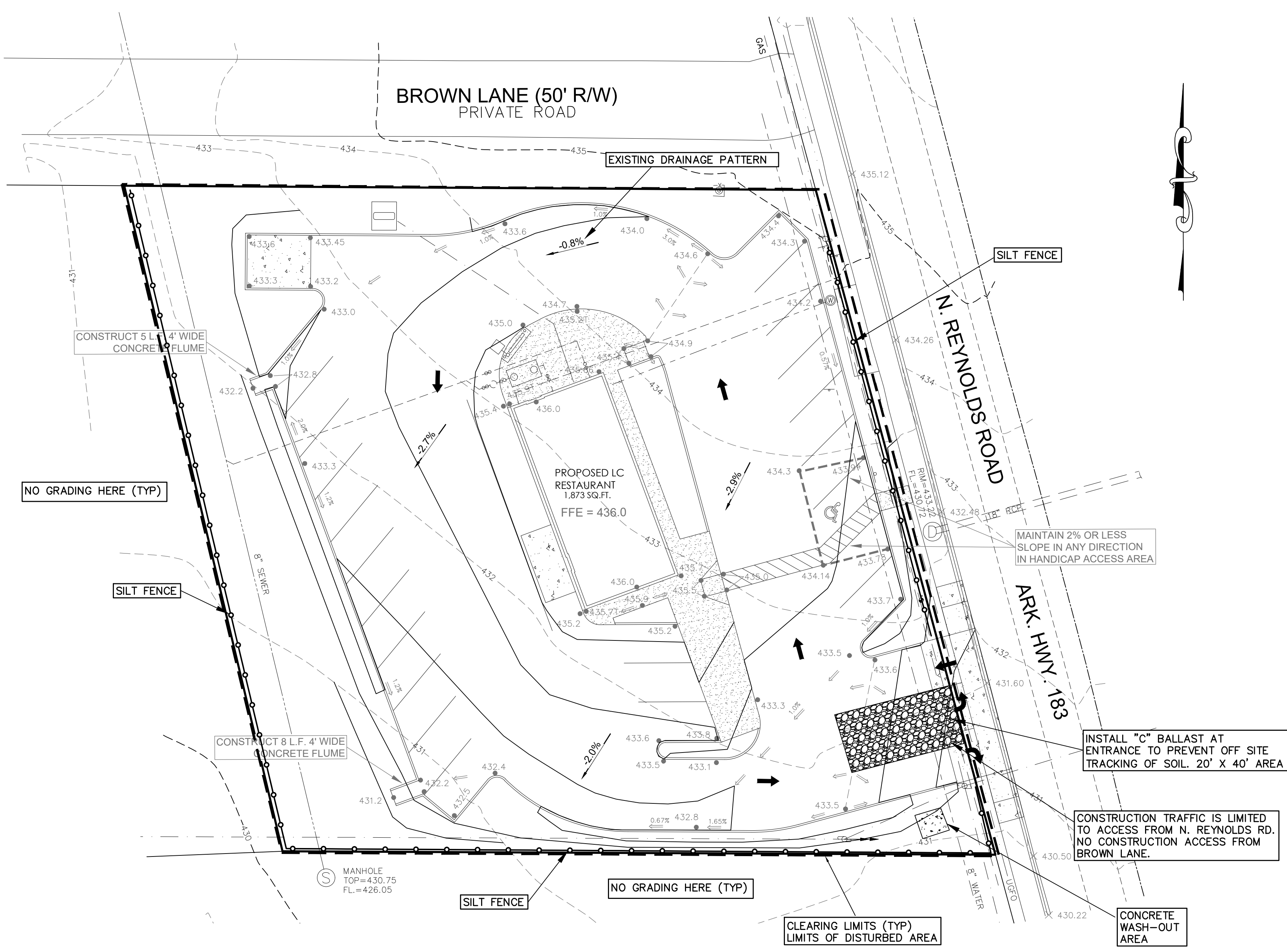
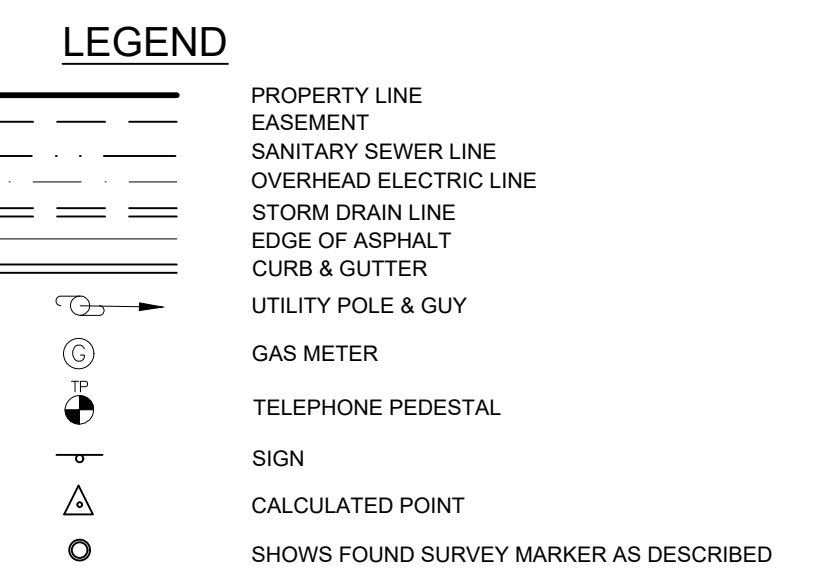
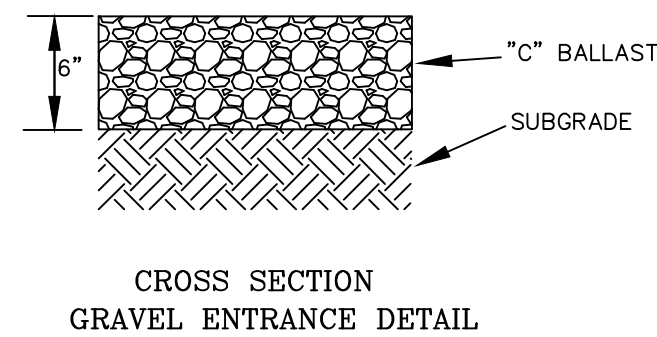
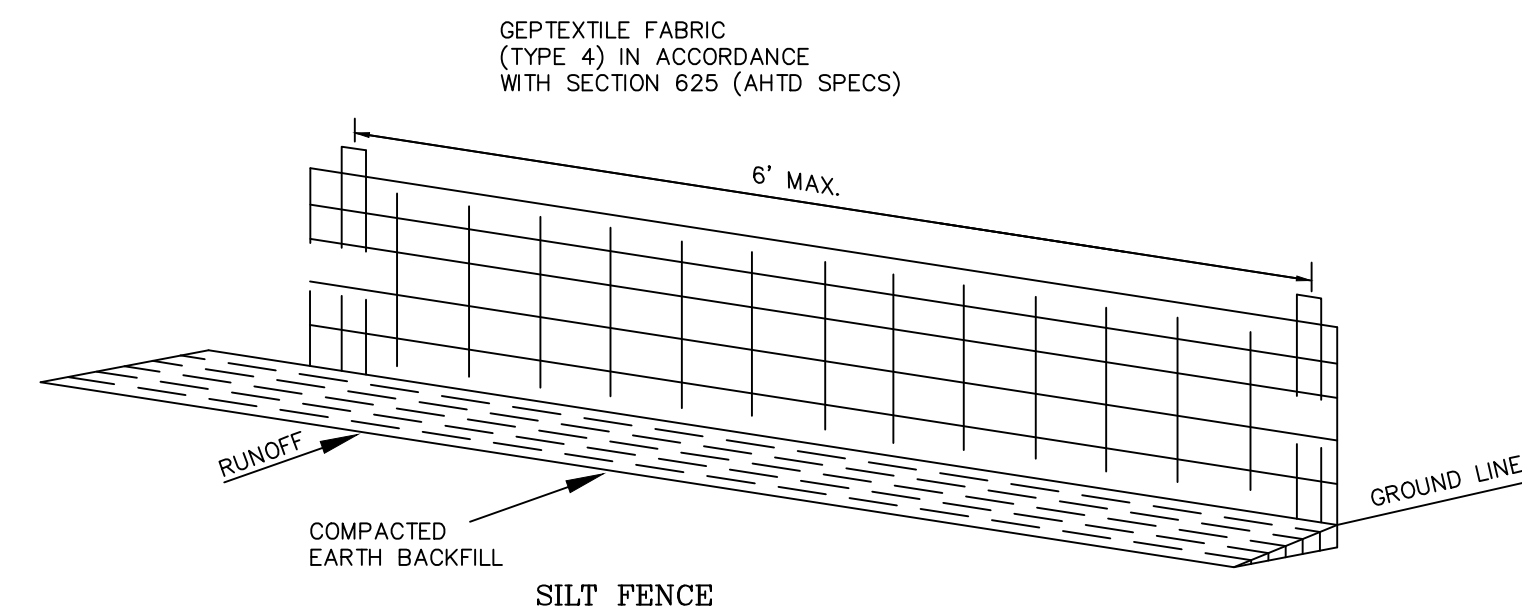

TOTAL SOIL DISTURBANCE ACREAGE= 0.9 AC.±  
TOTAL PROJECT ACREAGE= 0.9 AC.±

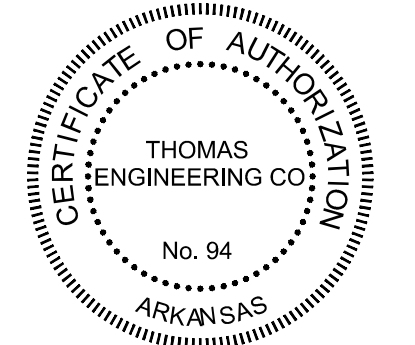
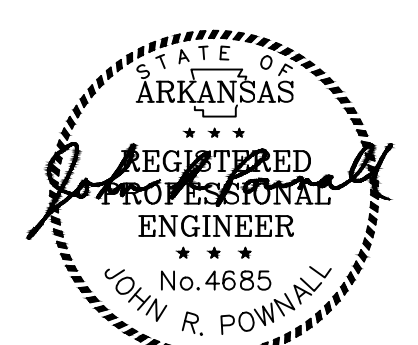
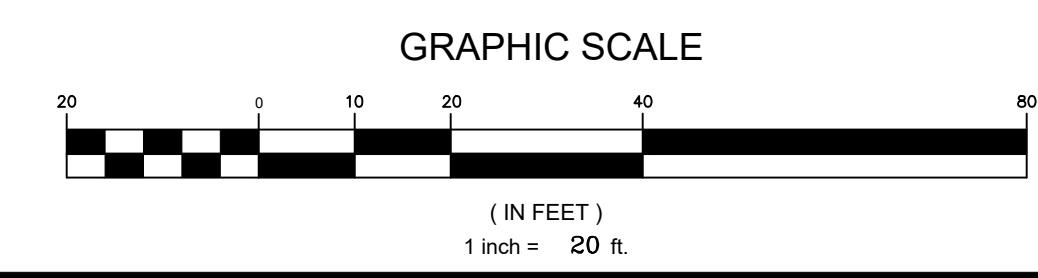

**THOMAS ENGINEERING COMPANY**  
3810 LOOKOUT ROAD, N. LITTLE ROCK, AR. 72116  
TEL: 501-753-4463 FAX: 501-753-6814

<b>EROSION CONTROL PLAN</b>			
LITTLE CAESARS BRYANT, ARKANSAS			
APPROVED	DRAWN BY	DATE	SHEET NO.
JRP	JRP	6/11/24	C5
SCALE 1" = 20'			

PRELIMINARY – NOT FOR CONSTRUCTION

LITTLE CAESARS-BRYANT-23-0165.dwg

PLOTTED: 6/20/2024

LITTLE CAESARS DETAILS.dwg

PLOTTED: 6/20/2024

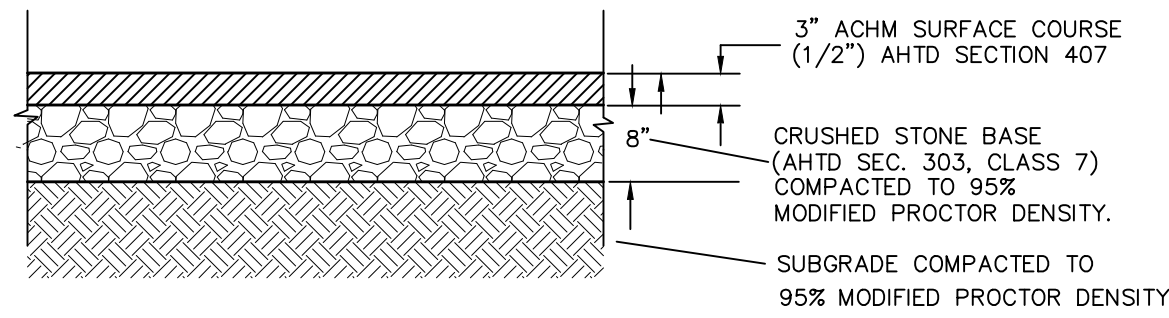

**HEAVY DUTY ASPHALT PAVEMENT**

NOTE: ASPHALT PAVEMENTS SHALL BE CONSTRUCTED IN ACCORDANCE WITH ARKANSAS HIGHWAY AND TRANSPORTATION DEPARTMENT SPECIFICATIONS.

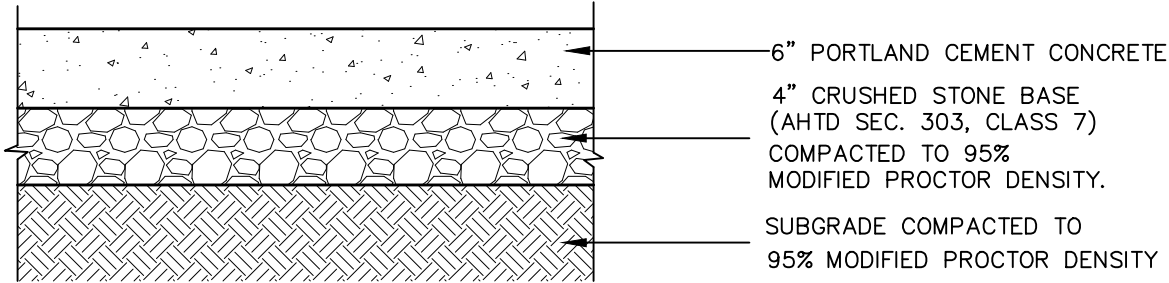

**LIGHT DUTY CONCRETE PAVEMENT**

LOAD TRANSFER DOWELS AND JOINTS PER ARDOT SPECS

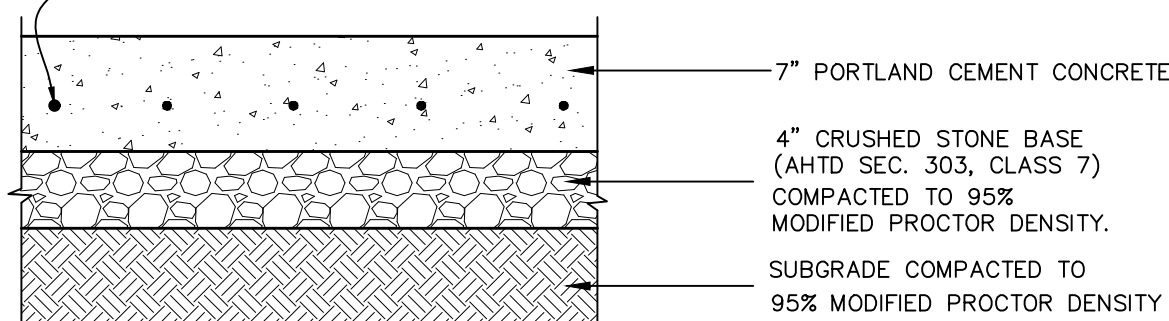

**DUMPSTER PAD CONCRETE PAVEMENT**

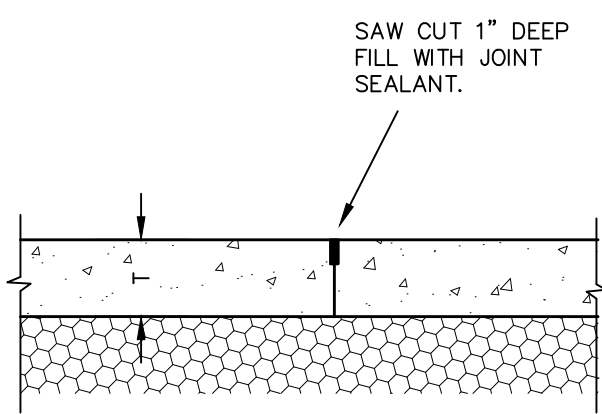

**CONTRACTION JOINT DETAIL**

NOTES ON CONCRETE PAVEMENT:

- 1. CONCRETE SHALL HAVE MINIMUM 4000 PSI COMPRESSIVE STRENGTH.
- 2. CONCRETE SHALL HAVE 5% AIR ENTRAINED.

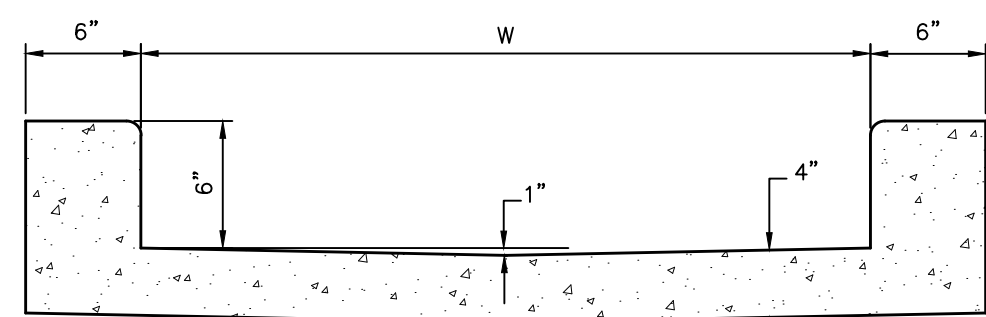

**CONCRETE CURB OPENING FLUME SECTION**

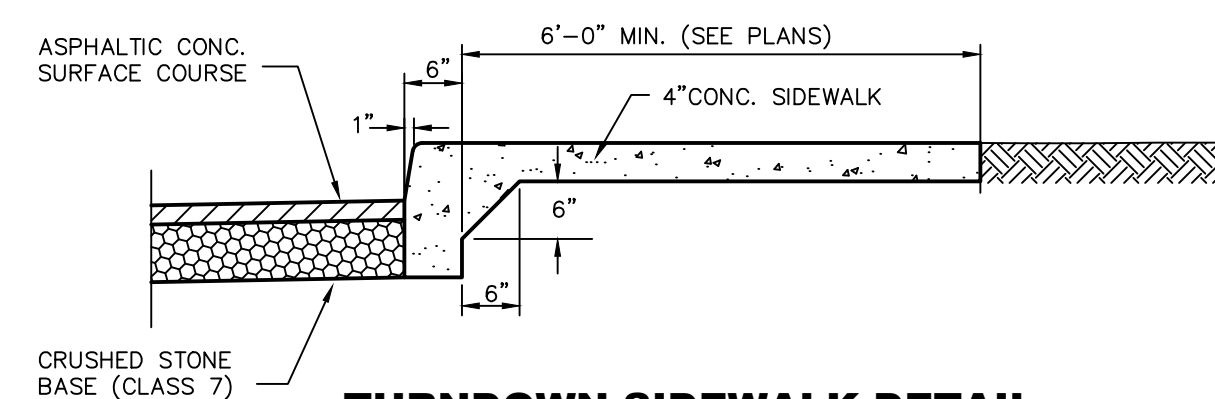

**TURNDOWN SIDEWALK DETAIL**

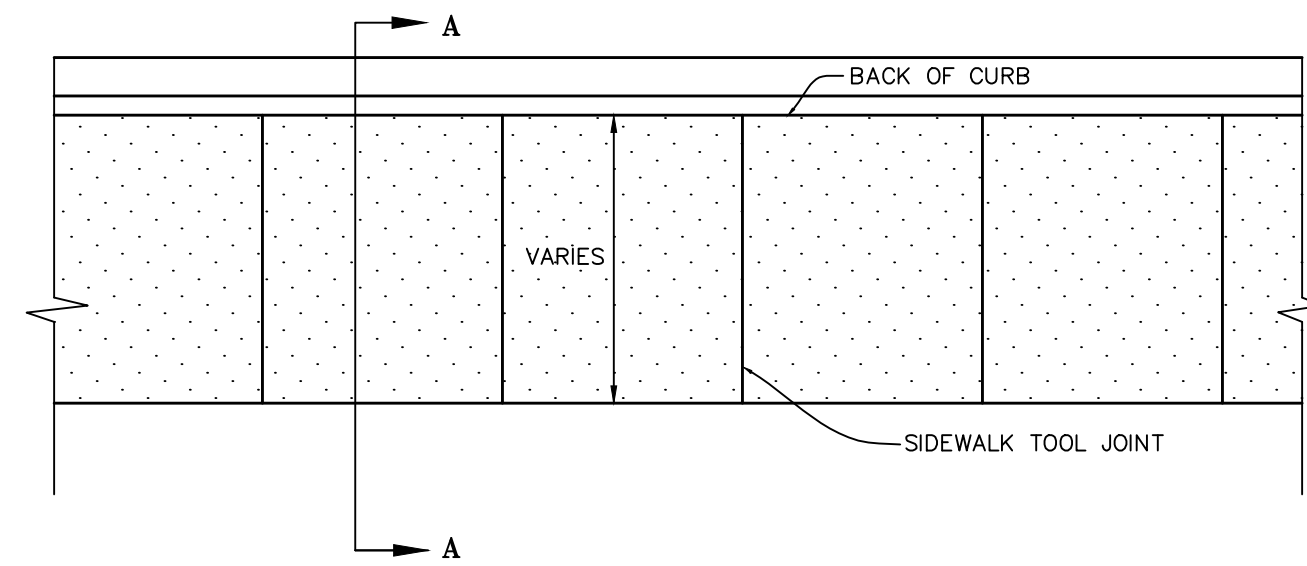

**SIDEWALK DETAIL (ADJACENT TO CURB) PLAN VIEW**

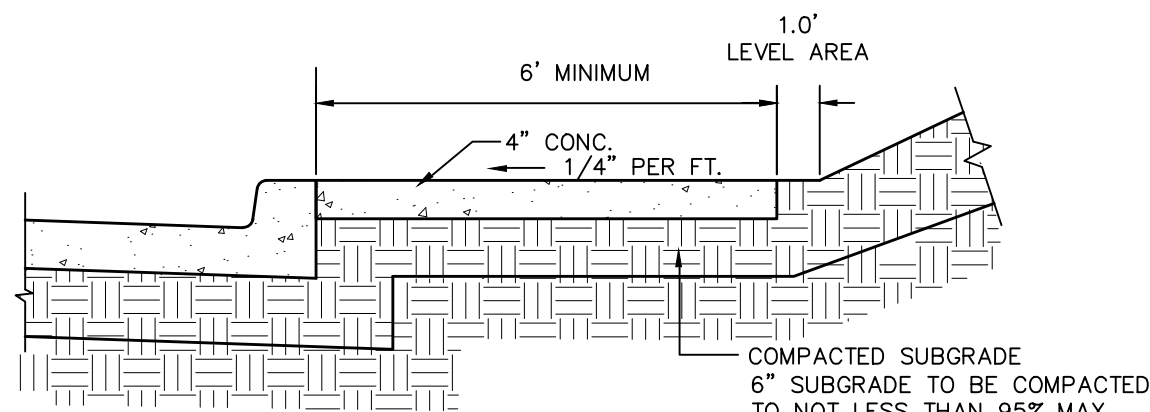

**SIDEWALK SECTION A - A**

- 1. 1/2" EXPANSION JOINT SPACING AT 60' AND AT STRUCTURES, DRIVES AND OTHER WALKS.
- 2. SIDEWALKS SHALL BE TOOLED AT LEAST 20% OF THE FULL DEPTH OF THE SIDEWALK AT 5' INTERVALS.
- 3. ALL CONCRETE SHALL HAVE 4000 PSI MINIMUM COMPRESSIVE STRENGTH.
- 4. SIDEWALK AGAINST CURB GRANTED ONLY WITH ENGINEER'S PERMISSION.

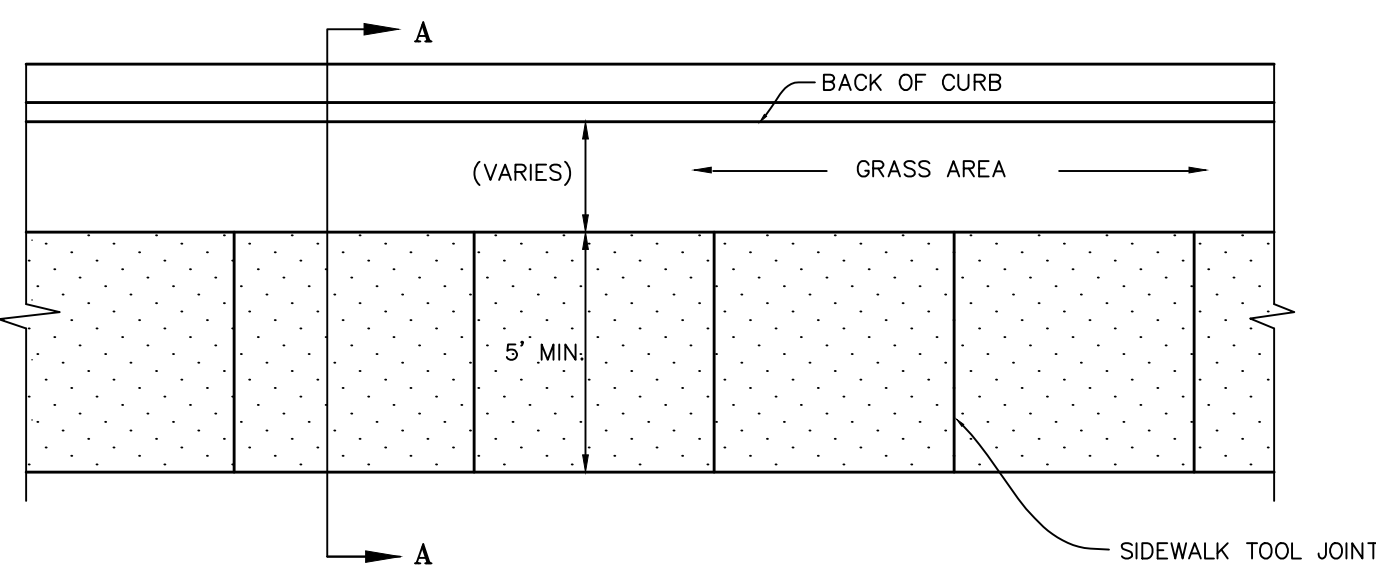

**SIDEWALK DETAIL PLAN VIEW**

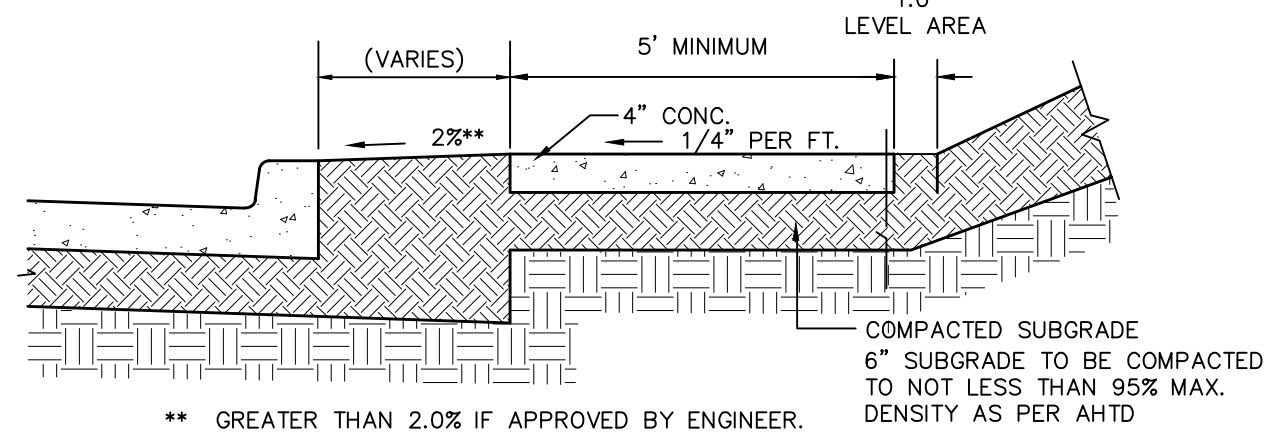

\*\* GREATER THAN 2.0% IF APPROVED BY ENGINEER.

**SIDEWALK SECTION A - A**

- 1. 1/2" EXPANSION JOINT SPACING AT 60' AND AT STRUCTURES, DRIVES AND OTHER WALKS.
- 2. SIDEWALKS SHALL BE TOOLED AT LEAST 20% OF THE FULL DEPTH OF THE SIDEWALK AT 5' INTERVALS.
- 3. ALL CONCRETE SHALL HAVE 4000 PSI MINIMUM COMPRESSIVE STRENGTH.

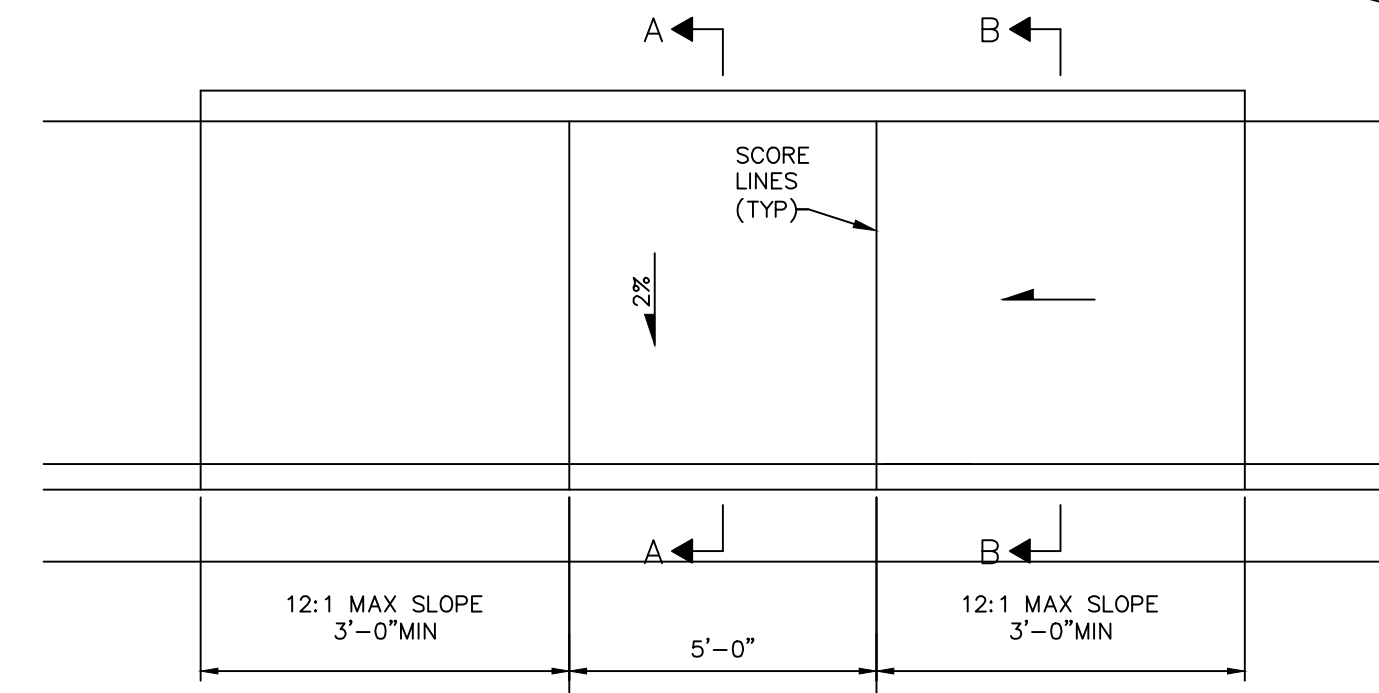
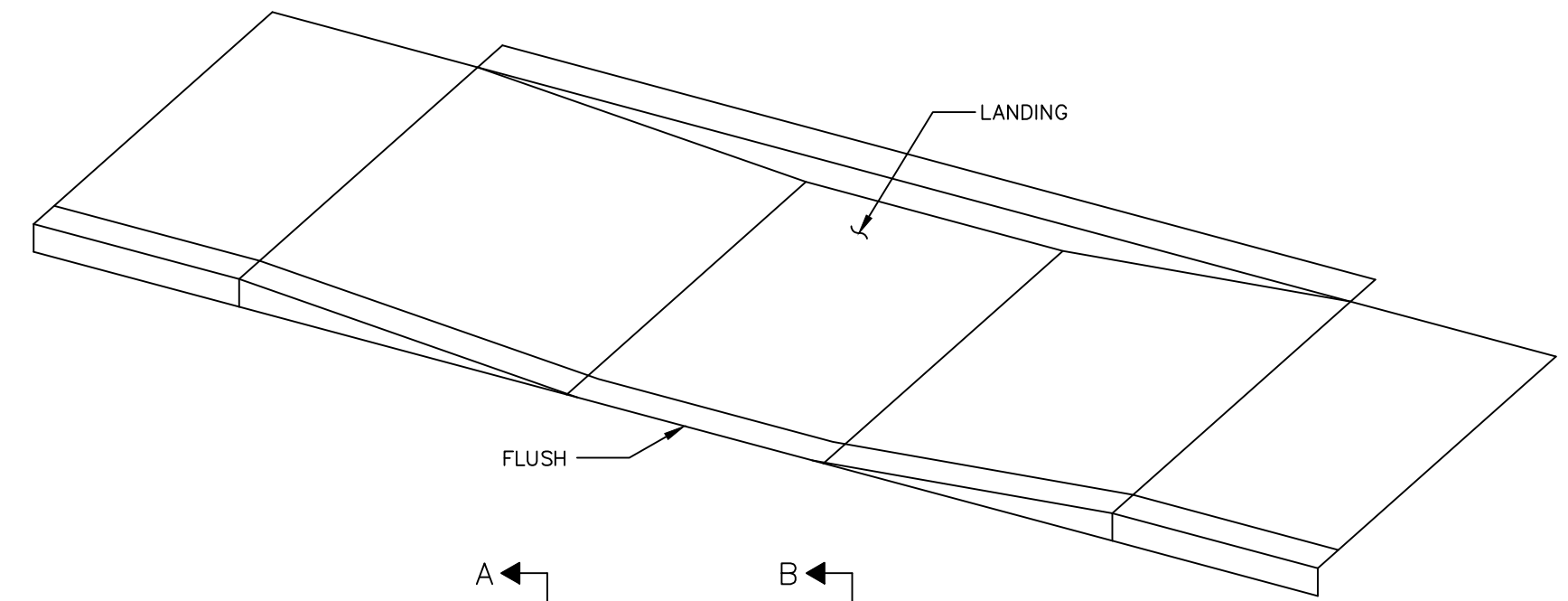

**ACCESSIBLE RAMP DETAIL**

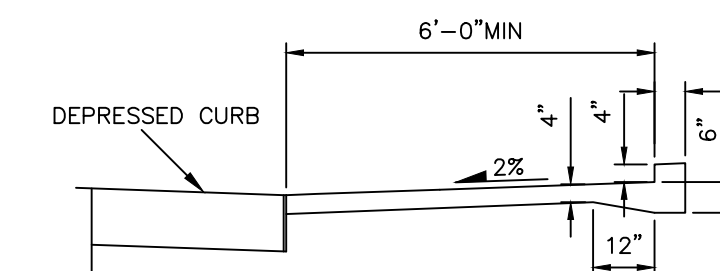

**SECTION A-A**

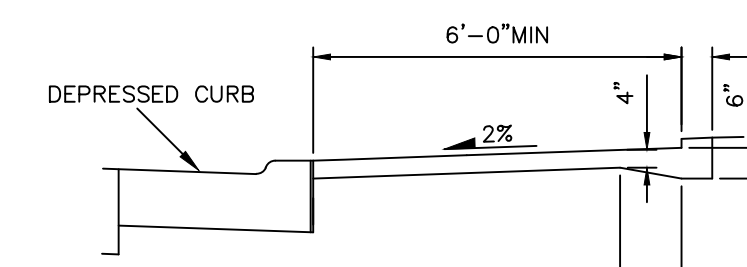

**SECTION B-B**

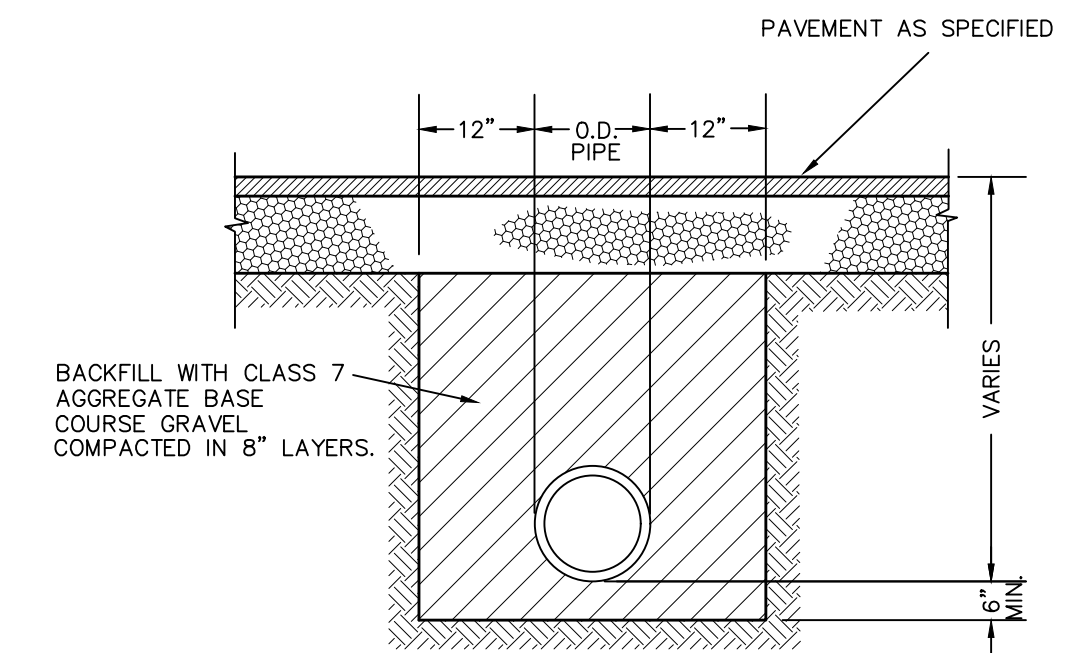

**PIPE TRENCH & BACKFILL SECTION DETAIL UNDER NEW PAVEMENT**

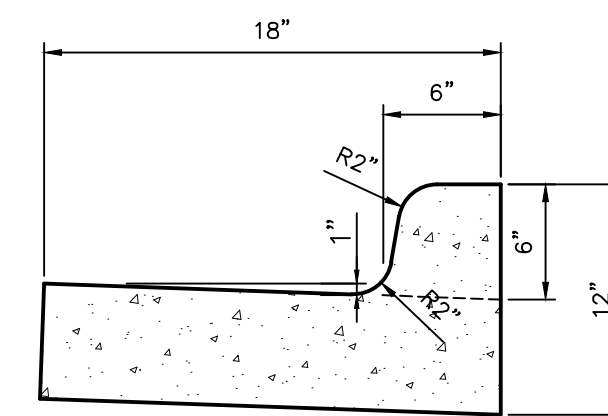

**TYPE "A" CURB 6" VERTICAL CURB**

NOTES ON CONCRETE CURB & GUTTER:

- 1. CONCRETE SHALL BE AHTD TYPE CLASS A OR CLASS S.
- 2. CONCRETE SHALL HAVE MINIMUM 4000 PSI COMPRESSIVE STRENGTH.
- 3. INSTALL 1/2" BITUMINOUS EXPANSION JOINT MATERIAL AT 100' MAXIMUM INTERVALS OR AT TIE INS TO BOXES, RADIUS RETURNS OR DRIVEWAY APRONS.
- 4. PROVIDE CONTROL JOINTS AT 15' MAXIMUM SPACING.
- 5. VERTICAL CURB ONLY BE USED WITH ENGINEER'S PERMISSION.
- 6. TYPE "B" CURB SHALL BE USED EXCEPT WHERE OTHER TYPES OF CURB ARE SPECIFIED ON THE PLANS.

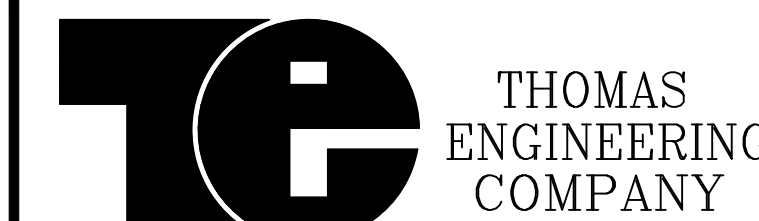
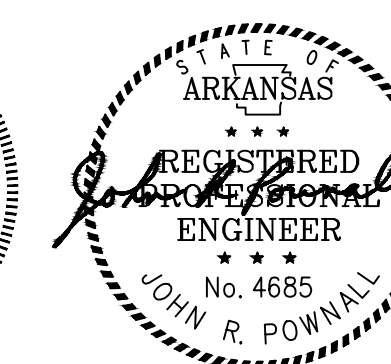
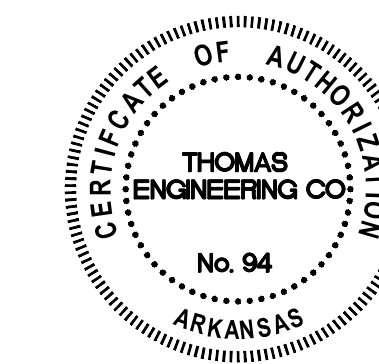

SITE DETAILS  
LITTLE CAESARS  
BRYANT, ARKANSAS

3810 LOOKOUT ROAD, N. LITTLE ROCK, AR. 72116  
TEL: 501-753-4463 FAX: 501-753-6814

APPROVED	DRAWN BY	DATE	SHEET NO.
SCALE	JRP	6/11/24	C6
NTS	23-0165		

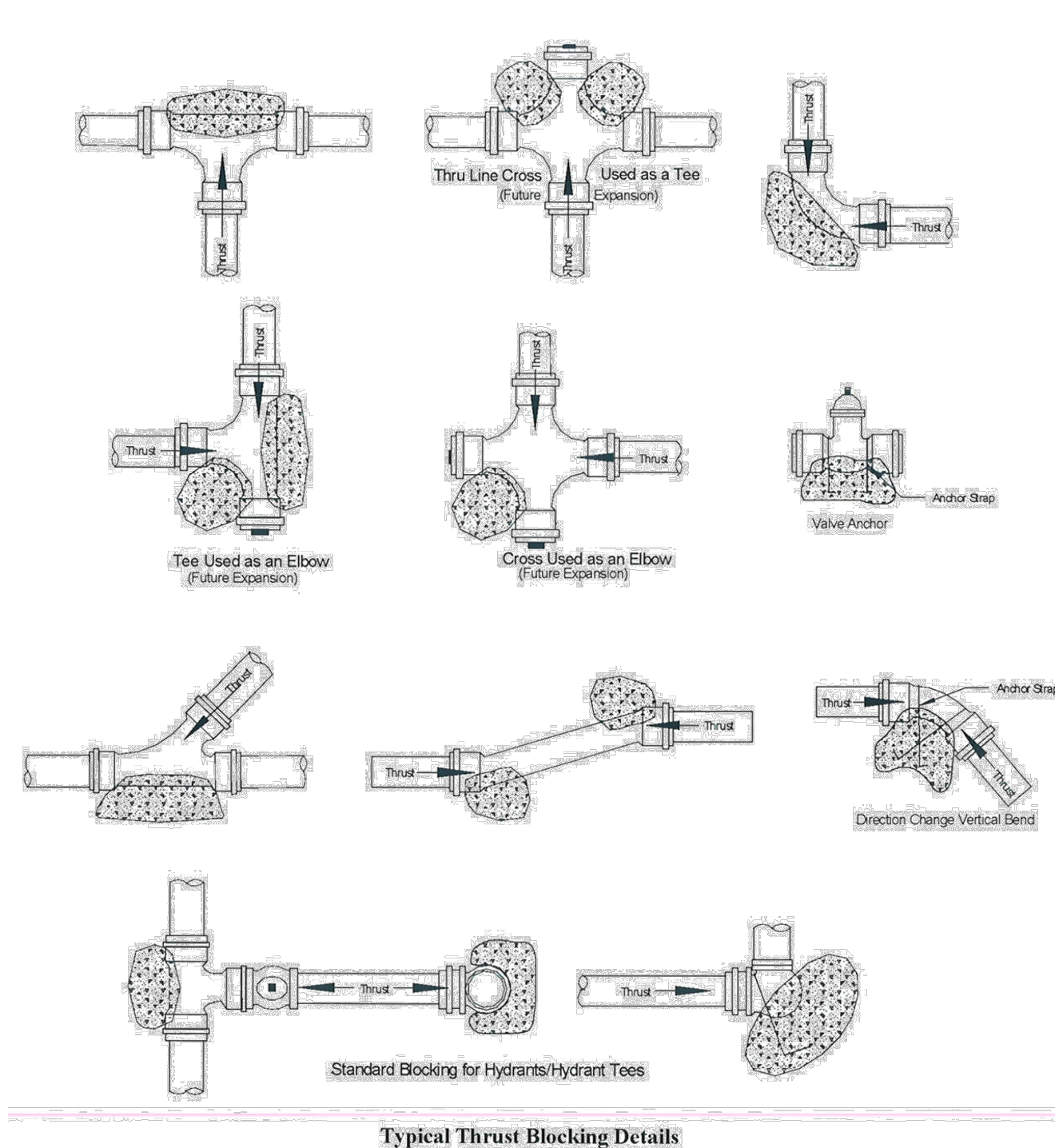

Typical Thrust Blocking Details

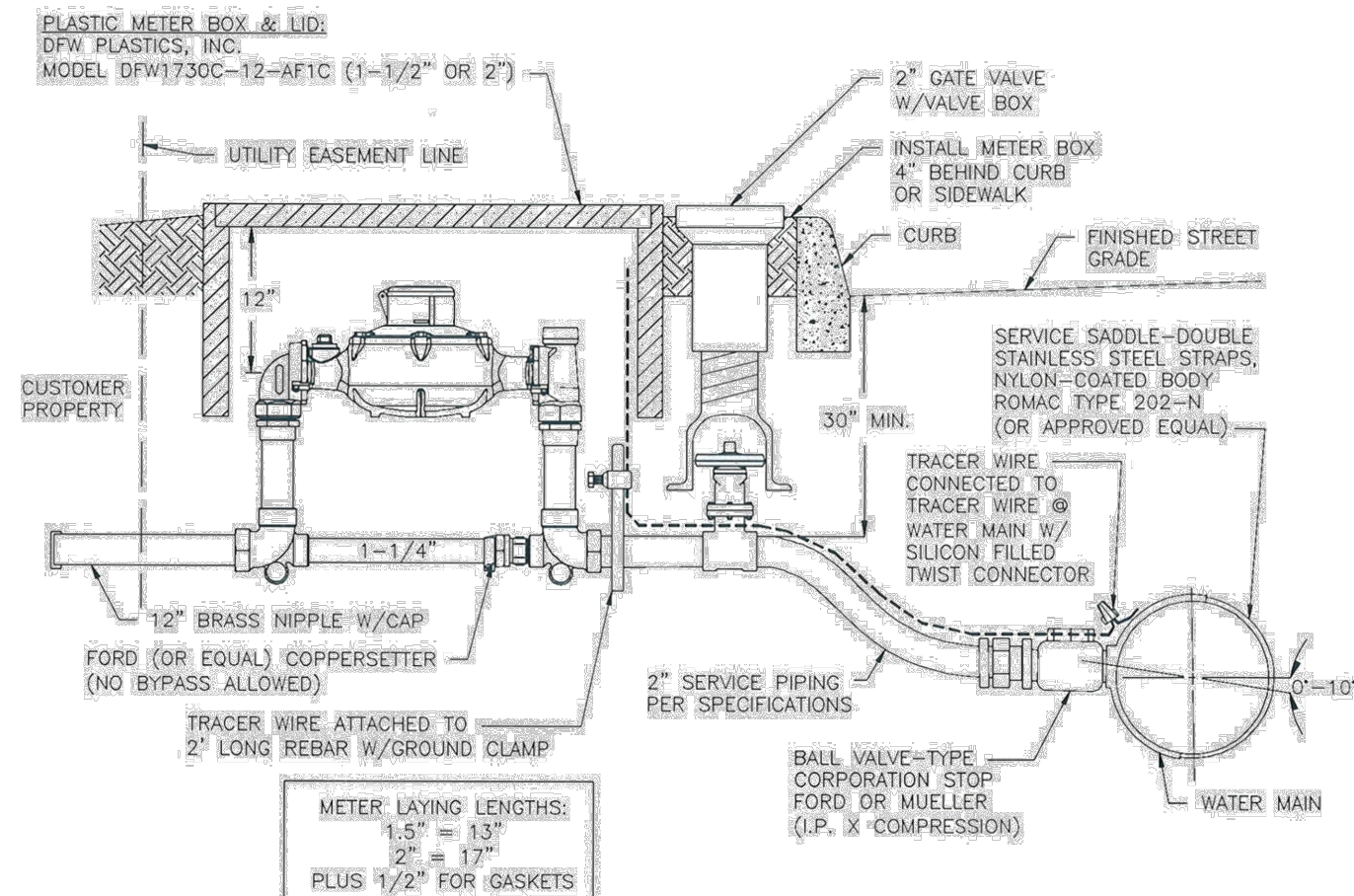

METER LAYING LENGTHS:  
 1.5" = 13"  
 2" = 17"  
 PLUS 1/2" FOR GASKETS

- NOTES:
1. PRIOR TO INSTALLATION OF METERS, ALL SERVICE APPLICATIONS MUST BE COMPLETED AND APPROVED, SERVICE FEES PAID IN FULL AND AS-BUILTS SUBMITTED AND APPROVED.
  2. METERS WILL NOT BE SET PRIOR TO DISINFECTION OF THE MAIN AND SERVICE OR PRIOR TO A SUCCESSFUL BACTERIOLOGICAL TEST.
  3. ALL METERS SHALL READ IN GALLONS, HAVE FLANGED ENDS, AND BE EQUIPPED WITH TEST PLUGS.
  4. METERS INSTALLED IN VAULTS SHALL BE EQUIPPED WITH REMOTE DISPLAY.
  5. APPROVED POSITIVE DISPLACEMENT METERS: BADGER, ELSTER, HERSEY, NEPTUNE, OR SENSUS.
  6. CUSTOMER METERS ARE NOT PERMITTED ON A.H.T.O., RIGHT-OF-WAY.

1.5" AND 2" STANDARD WATER METER SETTING DETAIL

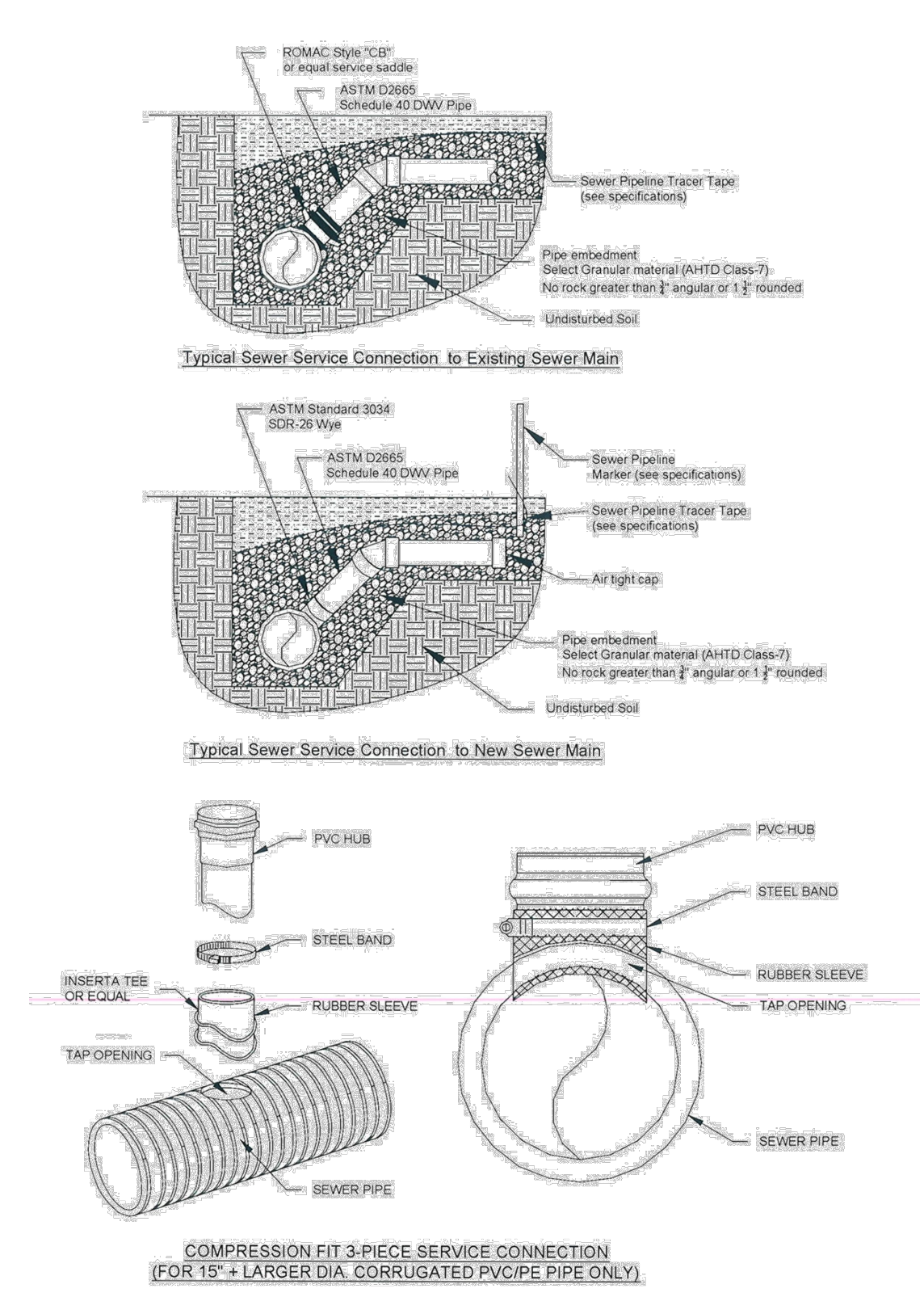

COMPRESSION FIT 3-PIECE SERVICE CONNECTION (FOR 15\"/>

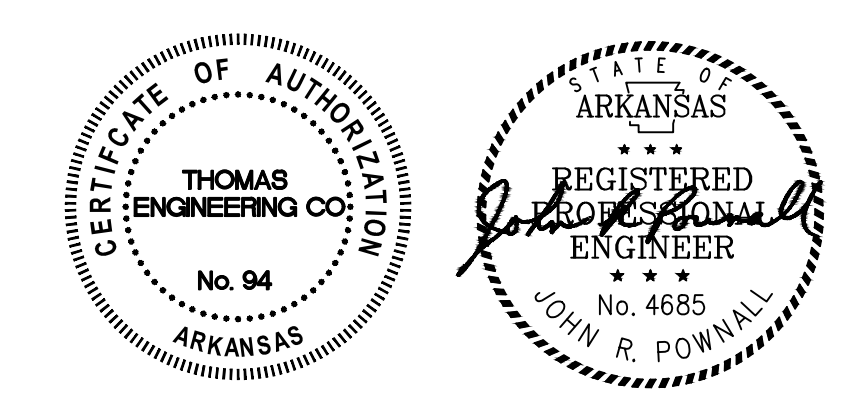

<p><b>THOMAS ENGINEERING COMPANY</b></p> <p>3810 LOOKOUT ROAD, N. LITTLE ROCK, AR. 72116                  TEL: 501-753-4463 FAX: 501-753-6814</p>	<p>WATER AND SEWER LINE DETAILS                  LITTLE CAESARS                  BRYANT, ARKANSAS</p>		<p>APPROVED</p>	<p>DRAWN BY                  JRP</p>	<p>DATE                  6/11/24</p>	<p>SHEET NO.  <b>C7</b></p>
	<p>SCALE                  NTS</p>	<p>23-0165</p>				