



Pre-Council Workshop

Boswell Municipal Complex - City Hall Court Room

210 SW 3rd Street

YouTube: <https://www.youtube.com/c/bryantarkansas>

Date: August 20, 2024 - **Time:** 6:00 PM

Call to Order

Old Business

New Business

Finance

1. Financial Report - Ending July 31, 2024

- [08.13.24 Financial Report ending July 31](#)
- [2024 DRAFT.pdf](#)

2. Budget Adjustments

- [08.13.24 Budget Adjustments List DRAFT.pdf](#)

3. Capital Purchases Report

4. Amendment 78 Discussion

5. New Ladder Truck Purchase

- [Ladder Truck.pdf](#)

Adjournments

RESOLUTION NO. 2024 _____

A RESOLUTION PROVIDING FOR THE ADOPTION OF AN AMENDED BUDGET FOR THE CITY OF BRYANT FOR THE TWELVE MONTH PERIOD BEGINNING JANUARY 1, 2024 AND ENDING DECEMBER 31, 2024

WHEREAS, the City of Bryant, Arkansas adopted a budget for The City of Bryant on December 19, 2023, recorded as Resolution 2023-XX, and

WHEREAS, the City of Bryant, Arkansas, desires to amend said Budget for Fiscal Year 2024 as attached.

NOW, THEREFORE, BE IT RESOLVED BY THE CITY COUNCIL OF BRYANT, ARKANSAS THAT:

Section This resolution (with attachment) shall be known as the amended budget resolution for the City of Bryant, Arkansas, for the twelve (12) month period beginning January 1, 2024 and ending December 31, 2024.

- 1.**
- General Fund 0.00
 - Investment Fund - ARPA 493,000.00
 - courts Auto Fund 25,000.00
 - state Drug Fund 100.00
 - Govt Debt Fund 182/183 0.00
 - Utility Revenue Fund 500 Water 100,000.00
 - Utility Fund WW (208,000.00)
 - Stormwater Fund (493,000.00)
 - Wastewater Impact 555 Fund 124,000.00
 - W.WW Depreciation Fund 184,000.00

Section The amended city budget for the calendar year 2024 is hereby amended and adopted to read as attached.
2.

PASSED AND APPROVED this 27th day of August, 2024.

APPROVED:

Chris Treat, Mayor

ATTEST:

Mark Smith, City Clerk

Account	Amount	Description
001-0300-5060	-1,000.00	Moving money from Travel/Train to Building Repair for Courts Bench
001-0300-5102	1,000.00	Moving money from Travel/Train to Building Repair for Courts Bench
001-0600-4702	204,500.00	Removing Grant Revenue PD decided not to apply
001-0600-5000	-204,500.00	Removing the associated payroll expense for the grant
007-0100-5626	493,000.00	Moving ARPA Investment to Stormwater Fund 515
031-0300-5608	25,000.00	Court Automation - new front speaker and metal detector
068-0600-5600	100.00	State Drug Control Fund
182-0800-4627	-35,000.00	Increasing bond transfers
183-0800-5626	35,000.00	Increasing bond transfers
500-0900-4640	100,000.00	Not going to do Hwy 5 with the state til 2025
510-0950-4626	-75,000.00	Emergency use of Depreciation funds - Sage Creek
510-0950-4640	100,000.00	Not going to do Hwy 5 with the state til 2025
510-0950-4623	-233,000.00	Moving from Impact and Depreciation Funds to Operating Budgets for WW
515-0140-4623	-493,000.00	Moving ARPA Investment to Stormwater Fund 515
525-0900-5626	184,000.00	Moving from Impact/DepFunds to Operating Budgets for WW and Sage
555-0950-5626	124,000.00	Moving from Impact and Depreciation Funds to Operating Budgets for WW



AGENDA ITEM HISTORY SHEET

ITEM TITLE

Approval to Purchase Rosenbauer 101' King
Cobra Ladder Truck

AGENDA NO.

AGENDA DATE: 8/27/2024

FUNDING CERTIFICATION (Finance Director) (Signature, if applicable)

MANAGEMENT STAFF REVIEW (Signature)

MAYOR (Signature)

ITEM HISTORY (Previous Council reviews, action related to this item, and other pertinent history)

Discussed during the July Pre-Council Workshop on July 23, 2024.

ITEM COMMENTARY (Background discussion, key points, recommendations, etc.) Please identify any or all impacts this proposed action would have on the City budget, personnel resources, and/or residents.

The cost of this ladder truck, with equipment, is \$2 million. This purchase will replace our 2007 E-One Bronto Ladder Truck. This request is approximately 2 years ahead of our replacement schedule due to multiple maintenance issues with our 2007 Ladder Truck and the difficulty of finding parts to repair it. We currently have a \$2,500 agreement with the manufacturer to hold this truck, a Rosenbauer 101' King Cobra Ladder Truck. This agreement expires on September 22, 2024. It is scheduled for completion in February of 2026. Other options for replacing our 2007 Bronto Ladder Truck will be at least 30-40 months completion.

(This section to be completed by the Mayor)

ACTION PROPOSED (Motion for Consideration)



MEMO INVOICE		
INVOICE #	DATE	PG
72324	7/23/2024	1

ROSENBAUER SOUTH DAKOTA, LLC
 100 Third Street • Lyons, SD 57041-0057
 Phone: (605) 543-5591 • Fax: (605) 543-5074

SOLD TO:

City of Bryant Fire Department
 Attn: Chief Brandon Futch
 312 Roya Lane
 Bryant, AR 72022

CUST ID	SALES PERSON	PURCHASE ORDER	TERMS	JOB NUMBER
BRYAAR	MIKE H	HOLD-7734	NET 60	7734

ORDERED	QUANTITY SHIPPED	DESCRIPTION	UNIT PRICE	AMOUNT
1.00	1.00	Hold for Stock Aerial (Job# 7734)	\$2,500.00	\$2,500.00
				\$0.00
		For Bryant Fire Department		\$0.00
				\$0.00
				\$0.00
		Payment will be due September 22, 2024 if stock aerial is not sold.		\$0.00
			SALES AMT	\$2,500.00
			FREIGHT	\$0.00
			STATE TAX	\$0.00
			CITY TAX	\$0.00
			TOTAL	\$2,500.00

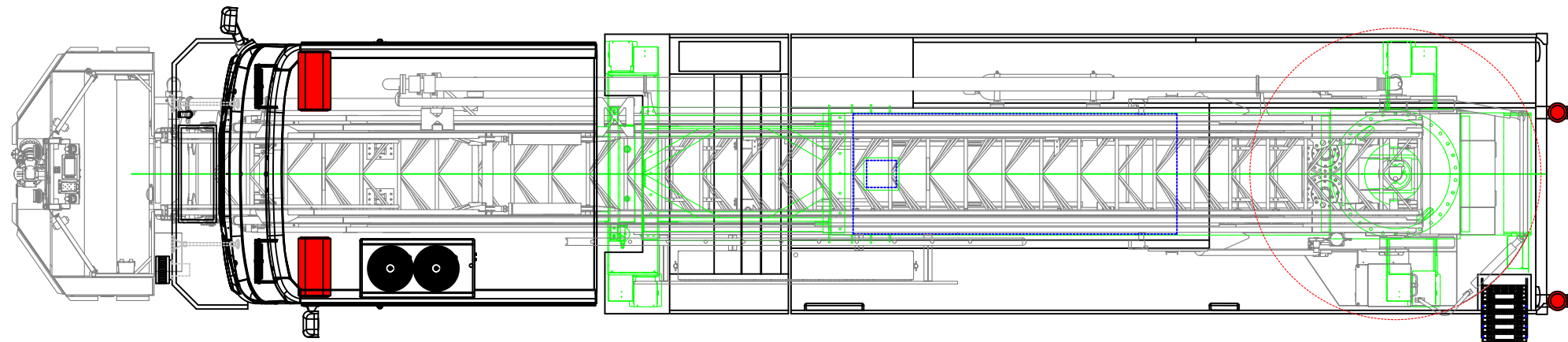

- NOTES:
1. OVERALL HEIGHT IS IN LOADED CONDITION. UNLOADED HEIGHTS MAY BE 4" ABOVE HEIGHTS SHOWN.
 2. DO NOT SCALE DRAWING.
 3. ALL DIMENSIONS ARE APPROXIMATE AND SUBJECT TO ENGINEERING CHANGES.
 4. DRAWING MAY OR MAY NOT SHOW ALL ITEMS AS DESCRIBED IN THE WRITTEN DETAIL SPECIFICATIONS.
 5. INCLUSION OF AN ITEM ON THE DRAWING DOES NOT CONSTITUTE INCLUSION OF THAT ITEM WITH THE FINAL DELIVERED UNIT.
 6. THE EFFECTIVE DOOR OPENINGS WILL BE APPROX. 2" LESS THAN THE NOTED COMPARTMENT OPENING FOR ROLL UP DOORS AND UP TO APPROX. 4" LESS FOR HINGED DOORS

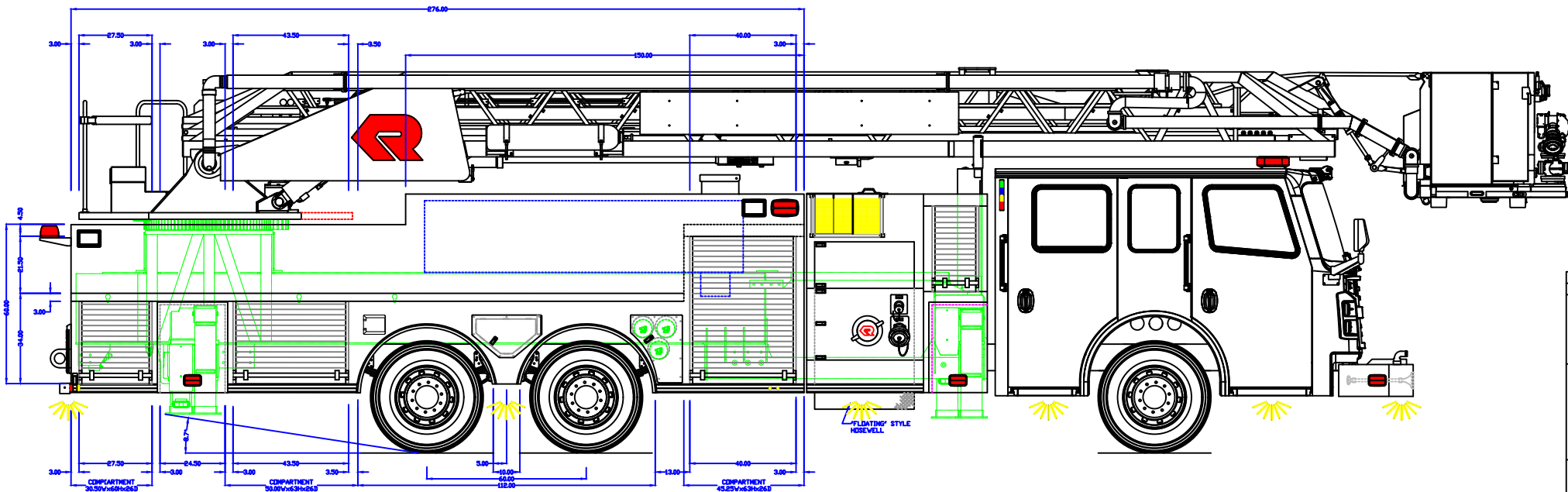
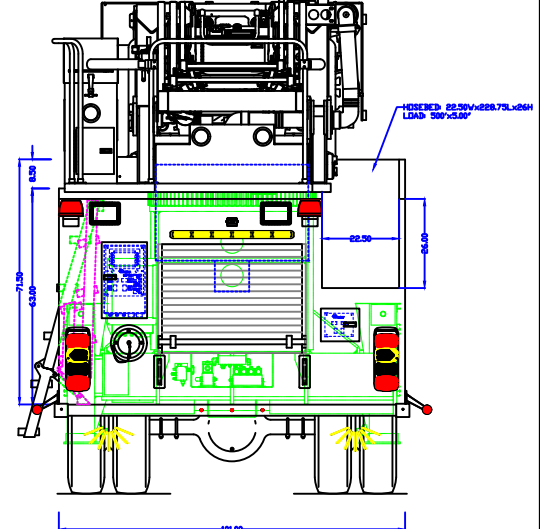
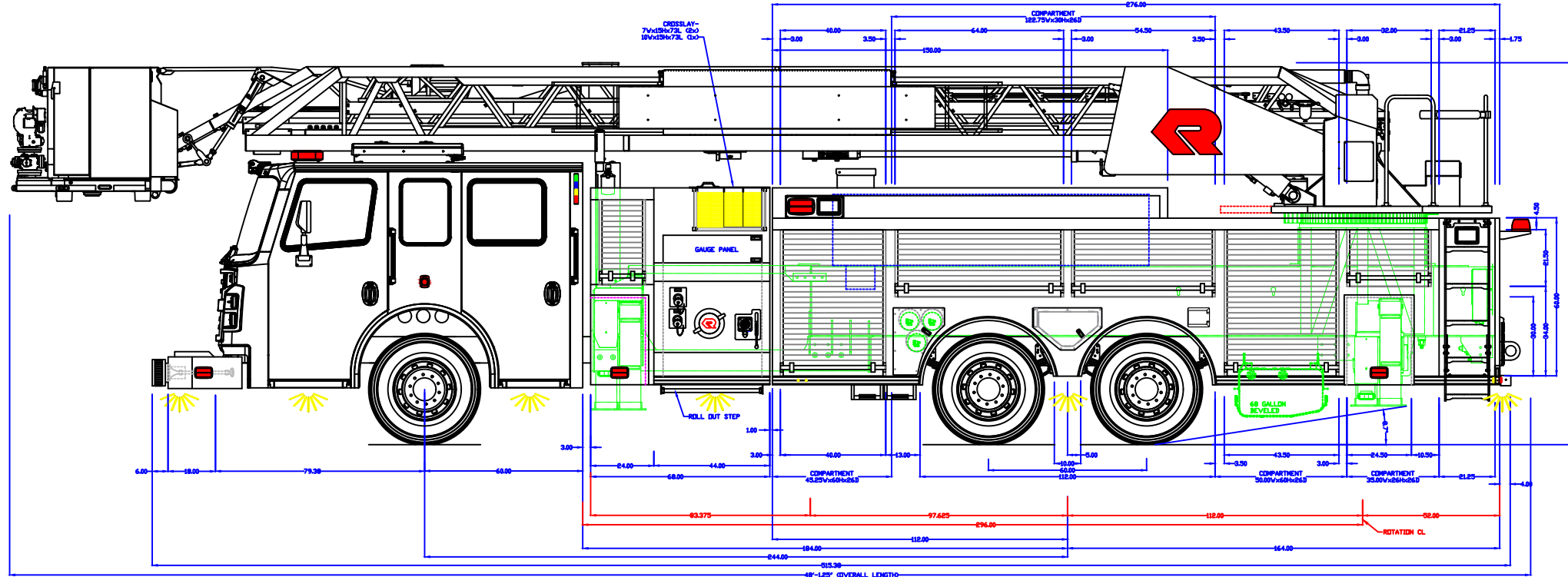
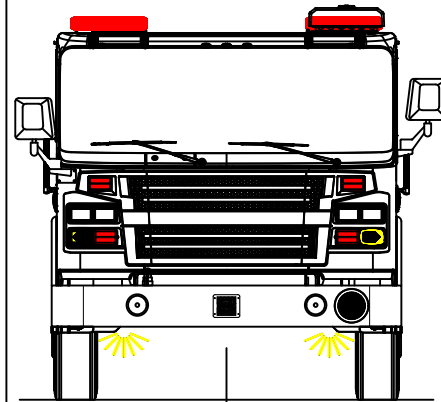
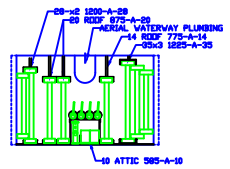

APPROVED BY:

CHASSIS:	COMMANDER 6000
PUMP:	WATEROUS 2000 GPM
TANK:	POLY/500/20(FOAM)
PANEL MATL:	LINE-X
COMP INTERIOR:	SPATTER COAT
MAXIMUM HEIGHT	NONE
MAXIMUM LENGTH	NONE
BODY WIDTH	101"

REV: 1 BPC DATE: 01-16-24
 DRAWN: BPC DATE: 11-17-23

PROPRIETARY AND CONFIDENTIAL
 THE INFORMATION CONTAINED IN THIS DRAWING IS THE SOLE PROPERTY OF ROSENBAUER. ANY REPRODUCTION IN PART OR AS A WHOLE WITHOUT THE WRITTEN PERMISSION OF ROSENBAUER IS PROHIBITED.

STOCK
101' KING COBRA

ROSENBAUER FX 3/16"

rosenbauer

DRAWING NUMBER: 470-D REV: 1