



**Bryant City Council
Regular Meeting
April 28th, 2015
Boswell Municipal Complex- City Hall Courtroom**

AGENDA

CALL TO ORDER

INVOCATION

PLEDGE OF ALLEGIANCE

Approval Of Minutes

January 2nd Special City Council Meeting Minutes

January 20th Special Council Meeting Minutes

January 27th Regular Council Meeting Minutes

February 24th Regular Council Meeting Minutes

March 31st Regular Council Meeting Minutes

Documents: [January 02 2015 Minutes FINAL.pdf](#), [January 20 2015 Minutes FINAL.pdf](#), [January 27,2015 Minutes FINAL.pdf](#), [Feb 24 2015 Minutes FINAL.pdf](#), [March 2015 Minutes FINAL.pdf](#)

ANNOUNCEMENTS And PRESENTATIONS

Mayors Office - Proclamations

Proclamation Recognizing May 3- 9 as Goodwill Industries Week

Proclamation for American Cancer Society Relay for Life

Proclamation Recognizing May as National Mental Health Awareness Month

Proclamation Recognizing May as National Preservation Month and Arkansas Heritage Month

Documents: [Nationalheritage.pdf](#), [RelayforLifeProclamation2015.pdf](#), [MentalHealthAwarenessMonthProclamation.pdf](#), [GoodwillProclamation2015.pdf](#)

COMMITTEE And COMMISSION REPORTS

DEPARTMENT REPORTS

- *Department Reports are given on a quarterly basis unless otherwise requested*

PUBLIC COMMENTS

- *Public Comments should be limited the three (3) minutes per speaker*

OLD BUSINESS

Finance Department

Joy Black Presenting

1. Presentation and Approval of the 2015 February Year to Date City Financial Report (tabled at March 31, 2015 meeting, see attachment)

Documents: [FebYTDRep2015.pdf](#)

NEW BUSINESS

Finance Department

Joy Black Presenting

2. Presentation and Approval of the 2015 March Year to Date City Financial Report (see attachment)

3. Resolution - A Resolution Providing for the Adoption of an Amended Budget for the City of Bryant for the twelve month period beginning January 1, 2015 and ending December 31, 2015 (see attachment)

4. Resolution - A Resolution Providing for the Revision of the Travel Policy for the City of Bryant, replacing any earlier versions in the Employee Handbook (see attachment)

Documents: [MarYTDRep2015.pdf](#), [BudAdjAprl2015.pdf](#), [ResTravlPolPerDiem \(2\).pdf](#)

Fire Department

Chief Jordan Presenting

5. Ordinance - An Ordinance Defining and limiting conditions for open burning within the City Limits of the City of Bryant; providing for enforcement; and for other purposes.

Sponsored by Councilman Higgenbotham, Councilman Roedel and Councilman Gladden

Documents: [OrdBrunDefCond.pdf](#)

Human Resources Department

Presenters: Brandon Griffin, Parks Director; Shari Knight, HR Director; and Joy Black, Finance Director

The Parks Director is requesting council approval for two new part-time positions:

6a. Resolution - A Resolution regarding a classification and compensation plan for the City of Bryant, Also, requesting Approval of Position Description and Classification for Parks Recreation Leader Part-time. Position has zero impact to the 2015 Budget.

6b. Resolution - A Resolution regarding a classification and compensation plan for the City of Bryant, Also, requesting a approval of Position Description and Classification for Parks Recreation Supervisor Part-time. Position has zero impact to the 2015 Budget.

Documents: [CACRecLdr042015.pdf](#), [PKSRecLdrPD042015.pdf](#), [CACRecSpv042015.pdf](#), [PKSRecSrvPD042015.pdf](#)

Legal Department

Presenter Chris Madison Staff Attorney - New Business

7. Ordinance with Emergency Clause - An Ordinance Amending Ordinance No. 2014-10 that Authorized the acquisition of certain land by eminent domain along Alcoa Road, Declaring an emergency and for other purposes.

8. Ordinance - An Ordinance defining the duties and responsibilities of Elected City Attorney.

Documents: [OrdAmndOrd201410.pdf](#), [OrdElecAttPros30k.pdf](#)

Parks Department

Presenter: Brandon Griffin, Parks Director

9. Approval of 2015 Barracuda Use Agreement - *Recommended by Parks Committee*

10. Approval of Shaved Ice Contract Service Contract Form - Requesting approval of contract form to begin offering shaved ice in Mills Park. *Recommended by Parks Committee.*

11. Resolution - A Resolution Expressing the Willingness of City of Bryant to Utilize Federal-Aid Recreational Trail Funds - Arkansas Recreational Trails Program Non-Motorized Trails Grant to resurface 1.3 miles of the Mills Park walking trail.

12. Ordinance - An Ordinance Amending Ordinance Nos.: 2000-30 and 1998-17 Regarding Permissible Possession and Consumption of Alcohol in Designated and Permitted Areas Within Certain City Parks; and for Other Purposes.

Documents: [BarracudaAgmt2015.pdf](#), [ShavedIceContract.pdf](#), [ResolutionTrailFunds.pdf](#), [OrdAlcoholParks.pdf](#), [Bryant Special Event 5.0.pdf](#)

Public Works Department - Presenter Monty Ledbetter

13. Resolution - Resolution adopting Standard Specifications for Design and Construction of Water Lines and Sewer Lines.

14. Resolution - Resolution Authorizing the Mayor to Enter into an Agreement to Exchange Real Estate between the City of Bryant and AG Investments LLC. (For improvements to Boone Road at its intersection with Tanglewood Drive.)

Documents: [ResWaterLineStds.pdf](#), [WaterSewerLineStds1.pdf](#), [WaterSewerLineStds2.pdf](#), [WaterSewerLineStds3.pdf](#), [WaterSewerLineStds4.pdf](#), [WaterSewerLineStds5.pdf](#), [ResBooneLandSwap.pdf](#), [DeedCOBProperty.pdf](#)

MAYOR COMMENTS

COUNCIL COMMENTS

ADJOURNMENT

210 SW 3rd St.
Bryant, AR 72022
[\(501\)943-0999](tel:(501)943-0999)



City Of Bryant

Bryant City Council

Special Meeting Minutes

January 02, 2015

UNOFFICIAL DRAFT

Swearing In Ceremony

- **Swearing in of newly Elected and Returning Elected Officials**

By Honorable Judge Stephanie Casady

Call to Order

- Mayor Dabbs call the City Council meeting to order.
- Alderman Present: Billingsley, Chandler, Gladden, Henson, Higginbotham, Miller, Permenter, Roedel,
- Clerk Ashcraft called roll and a quorum is present.
- Invocation given by Alderman Roedel
- Pledge of Allegiance

New Business

Legal Department Presenter Chris Madison

- **Approval of Resolution 2015-01 setting dates, times and Procedures for the City Council's meetings.**

Action taken: Motion made by Alderman Roedel to amend the time to 7: 00 pm and to approve the Resolution.

Seconded by Alderman Chandler

Voice Vote: 8 yeas and 0 nays **Passed**

Adjournment

Alderman Roedel made motion to adjourn and Seconded by Alderman Chandler

Voice Vote: 8 yeas & 0 nays - Meeting Adjourned

January, 02, 2015 minutes approved on this day, April 28th 2015

Mayor _____ ATEST City Clerk _____



**City of Bryant
Bryant City Council
Special Meeting Minutes**

January 20 - 2015 - Minutes
UNOFFICIAL DRAFT

CALL TO ORDER

- Mayor Dabbs called meeting to order.
- Present Alderman Billingsley, Chandler, Gladden, Higginbotham, Miller, Roedel
Alderman Absent Henson, Permenter
- Clerk Ashcraft called roll and a quorum is present.

NEW BUSINESS

PARKS Presenter Derek Phillips Parks Director.

- Replacement of a motor (Pool PAK) for labor and replacement to be around \$3600.00.

Action taken: Alderman Roedel made motion to allow up to \$5000.00 for repairs.

Seconded by Alderman Miller

Voice Vote: 6 yeas & 2 nays (Absent Alderman Henson & Alderman Permenter) **Passed**

- **Action taken:** Alderman Roedel made a motion that funds come from General funds.

Seconded by Alderman Miller

Voice Vote: 6 yeas & 2 nays (Absent Alderman Henson & Alderman Permenter) **Passed**

Adjournment

- Motion made by Alderman Roedel to adjourn

Second by Alderman Miller

Meeting adjourned.

January, 20th, 2015 minutes approved on this day, April 28th 2015

Mayor _____

ATEST

City Clerk _____



City of Bryant Regular Monthly Council Meeting
Tuesday, March 31, 2015 – 7:00 pm
Boswell Municipal Complex – City Hall Courtroom
210 S.W. 3rd Street, Bryant, Ar. 72022

UNOFFICIAL DRAFT

January 27th 2015

CALL TO ORDER

- Mayor Dabbs called the meeting to order at 7:00pm.
- ROLL CALL: PRESENT: Alderman Billingsley, Chandler, Gladden, Higginbothan, Miller, Permenter, Roedel ABSENT: Hensen
- Clerk Ashcraft called roll to confirm that we have a quorum present, quorum present.
- INVOCATION: Lead by Alderman Billingsley
- PLEDGE OF ALLEGIANCE Said by all with PRIDE

APPROVAL OF MINUTES

Approval of December 2014 Minutes - TABLED

MOTION MADE BY: Alderman Roedel

SECONDED: Alderman Chandler

VOICE VOTES: 7 YEAS (Hensen absent) **PASSED**

ANNOUNCEMENTS and PRESENTATIONS

- **POLICE:** Chief Kizer presented awards to SGT Keith Byrd for 20 years of service and Captain Phillip Newcomb for 26 years of service.
- **PARKS:** Derk Phillips, Park Director announced that he will be leaving Bryant to accept a job back home.
- **OTHER:** Mayor Dabbs reminded everyone that The Bryant Chamber's Banquet will be Thursday night and there is still time to buy tickets.

COMMITTEE and COMMISSION REPORTS

NONE

DEPARTMENT REPORTS Presented by: Joy Black

OLD BUSINESS

NONE

NEW BUSINESS

FINANCE DEPARTMENT PRESENTER JOY BLACK:

- **2015-2 Resolution** PROVIDING FOR THE ADOPTION OF AN AMENDED BUDGET FOR THE CITY OF BRYANT WATER/WASTEWATER DEPARTMENT FOR THE TWELVE MONTH PERIOD BEGINNING JANUARY 1, 2014 AND ENDING DECEMBER 31, 2014

ACTION TAKEN: MOTION MADE BY: Alderman Chandler to approve.

SECOND: Alderman Higginbotham

VOICE VOTE: 7 yeas & 1 nay Absent Alderman Hensen **PASSED**

- **2015-3 APPROVAL OF A RESOLUTION** PROVIDING FOR THE ADOPTION OF AN ADMEN BUDGET FOR THE City OF BRYANT GENERAL, STREETS, AND OTHER FOR THE TWELVE MONTH PERIOD BEGINNING JANUARY 1, 2014 AND ENDING DECEMBER 31,2014

ACTION TAKEN: MOTION MADE BY: Alderman Miller to approve.

SECOND: Alderman Roedel

VOICE VOTE: 7 yeas & 1 nay Absent Alderman Hensen **PASSED**

- **2015-4 RESOLUTION** PROVIDING FOR THE ADOPTION OF AN AMENDED BUDGET FOR THE CITY OF BRYANT FOR THE TWELVE MONTH PERIOD BEGINNING JANUARY 1, 2015 AND ENDING DECEMBER 31 2015

ACTION TAKEN: MOTION MADE BY: Alderman Roedel to approve.

SECOND: Alderman Billingsley

VOICE VOTE: 7 yeas & 1 nay absent Alderman Hensen **PASSED**

- **2015-5 RESOLUTION ADOPTING** A RECORD RETENTION PROCESS AND POLICY FOR THE CITY OF BRYANT

ACTION TAKEN: MOTION MADE BY : Alderman Higginbotham to approve.

SECOND: Alderman Billingsley

VOICE VOTE: 7 yeas & 1 nay Absent Alderman Hensen **PASSED**

Human Resources Department Presenters: Shari Knight, Human Resources Director, Monty Ledbetter, Public Works Director and Joy Black, Finance Director

- **RESOLUTION 2015-6**

The Public Works Director is requesting council approval of the reclassification and rewrite of the Lead Meter Reader & Field Technician position to that of Meter Services Coordinator. This position change will have an impact on budget.

ACTION TAKEN: MOTION MADE BY: Alderman Permenter to approve.

SECONDED: Alderman Gladden

VOICE VOTE: 7 yeas & 1 nay Absent Alderman Hensen **PASSED**

Legal Department

- **2015-1 ORDINANCE** AUTHORIZING A CONTRACT FOR ADDITIONAL SERVICES WITH THE BOYS AND GIRLS CLUB OF BRYANT, WAIVING COMPETITIVE BIDDING; DECLARING AN EMERGENCY AND FOR OTHER PURPOSES

ACTION TAKEN: MOTION TO SUPEND THE RULES AND READ BY TITLE ONLY MADE

BY: Alderman Higginbotham **SECOND:** Alderman Permenter

VOICE VOTE: 7 yeas & 1 nay Absent Alderman Hensen **PASSED**

MOTION TO SUPEND 2ND AND 3RD READING AND READ BY TITLE ONLY MADE BY: Alderman Roedel **SECOND** Alderman Miller

VOICE VOTE: 7 yeas & 1 nay Absent Alderman Hensen **PASSED**

ACTION TAKEN: MOTION TO ADOPT: Alderman Miller to approve.

SECOND: Alderman Roedel

VOICE VOTE: 7 yeas & 1 nay Absent Alderman Hensen **PASSED**

- **2015- 2 ORDINANCE** AUTHORIZING A CONTRACT FOR SERVICES WITH THE BRYANT SENIOR ADULT CENTER COUNCIL, WAIVING COMPETITIVE BIDDING, DECLARING AND EMERGENCY AND FOR OTHER PURPOSES.

ACTION TAKEN: MOTION MADE TO SUPEND THE RULES AND READ BY TITLE ONLY

BY: Alderman Higginbotham

SECOND: Alderman Permenter

VOICE VOTE: 7 yeas & 1 nay Absent Alderman Hensen **PASSED**

ACTION TAKEN: MOTION TO SUPEND 2ND AND 3RD READING AND READ BY TITLE ONLY

MADE BY: Alderman Miller

SECOND Alderman Higginbotham

VOICE VOTE: 7 yeas & 1 nay Absent Alderman Hensen **PASSED**

ACTION TAKEN: MOTION TO ADOPT: Alderman Roedel

SECOND: Alderman Permenter

VOICE VOTE: 7 yeas & 1 nay Absent Alderman Hensen **PASSED**

- **2015 - 7 RESOLUTION** AUTHORIZING EXECUTION OF PROGRAM AGREEMENT WITH THE CENTRAL ARKANSAS DEVELOPMENT COUNCIL OPERATING AS THE BRYANT SENIOR ADULT CENTER.

ACTION TAKEN: MOTION MADE BY Alderman Higginbotham to approve.

SECOND: Alderman Permenter

VOICE VOTE: 7 yeas & 1 nays Absent Alderman Hensen **PASSED**

- **2015- 8 RESOLUTION** REGARDING THE SALINE COUNTY REGIONAL SOLID WASTE MANAGEMENT IN SUPPORT OF PETITION TO EXPAND ITS LANDFILL UNDER ADEA REGULATIONS

ACTION TAKEN: MOTION MADE BY: Alderman Roedel to approve.

SECOND: Alderman Billingsley

VOICE VOTE: 7 yeas & 1 nay Absent Alderman Hensen **PASSED**

- **2015- 3 ORDINANCE ADOPTING** REGULATIONS FOR THE CITY OF BRYANT WHICH GOVERN THE SALE OF ALCOHOL WITHIN THE CITY ESTABLISHING THE REQUIREMENTS TO MAINTAIN A CITY ALCOHOL PERMIT, LEVYING CERTAIN FEES THEREON, LEVYING A SUPPLEMENTAL TAX ON THE SALE OF CERTAIN CONTROLLED BEVERAGES, PRESCRIBING PENALTIES FOR THE ENFORCEMENT OF SAME, DECLARING AN EMERGENCY, AND FOR OTHER PURPOSES.

ACTION TAKEN: MOTION TO SUPEND THE RULES AND READ BY TITLE ONLY MADE

BY: Alderman Permenter

SECOND: Alderman Chandler

VOICE VOTE: 7 yeas & 1 nay Absent Alderman Hensen **PASSED**

ACTION TAKEN: MOTION TO SUPEND 2ND AND 3RD READING AND READ BY TITLE ONLY MADE BY: Alderman Roedel

SECOND Alderman Higginbotham

VOICE VOTE: 7 yeas & 1 nay Absent Alderman Hensen **PASSED**

ACTION TAKEN: MOTION TO ADOPT BY : Alderman Chandler

SECOND: Alderman Miller

ROLL CALL VOTE: 7 yeas & 1 nay Absent Alderman Hensen **PASSED**

- **ORDINANCE WITH EMERGENCY CLAUSE** - DEFINING THE DUTIES AND RESPONSIBILITIES OF THE ELECTED CITY ATTORNEY FOR THE CITY OF BRYANT, ARKANSAS AND DECLARING AND EMERGENCY.

Ordinance TABLED

ACTION TAKEN: MOTION MADE TO TABLE BY: Alderman Permenter

SECOND: Alderman Roedel

ROLL CALL VOTE: NAYS: Alderman Miller, Alderman Gladden, Alderman Hensen(absent)

YEAS: Alderman Higginbotham, Alderman Permenter, Alderman Chandler, Alderman Billingsley, Alderman Roedel **PASSED**

Parks Department Presenter: Derek Phillips, Parks Director

- **Approval** of Sport Use Agreements:
 - a) Bryant Athletic Association
 - b) Bryant Softball Association
 - c) Bryant Soccer Club

ACTION TAKEN: MOTION MADE TO APPROVE ALL THREE: Alderman Roedel

SECOND: Alderman Billingsley

VOICE VOTE: 7 yeas & 1 nay Absent Alderman Hensen **PASSED**

- **Approval** to spend \$7,300 on two loads of mulch out of expense line Supplies-Operating 001-0400-5322.

ACTION TAKEN: MOTION MADE TO APPROVE BY: Alderman Miller

SECOND: Alderman Higginbotham

VOICE VOTES: 7 yeas & 1 nay Absent Alderman Hensen **PASSED**

- **Approval to spend** \$20,000 on four loads of in field mix and four loads of SAF coat out of expense lines Supplies Operating 001-0400-5322 (\$5,000) and Repairs and Maintenance - Grounds 001-0430-5104 (\$15,000).

ACTION TAKEN: MOTION MADE TO APPROVE BY: Alderman Roedel

SECOND: Alderman Chandler

VOICE VOTE: 7 yeas & 1 nay Absent Alderman Hensen **PASSED**

Planning Department - Presenter Dave Green, Planning Director

- **2015-9 RESOLUTION** ACCEPTING THE OLD TOWN BRYANT JUMP START REPORT

ACTION TAKEN: MOTION MADE TO CHANGE THE NAME TO "THE HEART OF BRYANT"

BY: Alderman Roedel

SECOND: Alderman Higginbotham

VOICE VOTE: 7 yeas 1 nay Absent Alderman Hensen **PASSED**

Public Works - Water and Wastewater Presenter Monty Ledbetter

2015- 10 RESOLUTION TO AUTHORIZE PROPOSED WATER LEAK ADJUSTMENT POLICY

ACTION TAKEN: MOTION MADE TO APPROVE BY: Alderman Chandler

SECOND: Alderman Permenter

VOICE VOTE: 7 yeas & 1 nay Absent Alderman Hensen **PASSED**

- **2015- 4 ORDINANCE TO AMEND ORDINANCE NO 2011-30** AND ESTABLISH RATES FOR SERVICES RENDERED BY THE SEWER FACILITIES OF THE WATER AND WASTEWATER SYSTEM OF THE CITY OF BRYANT, AR AND PRESCRIBING OTHER MATTERS RELATING THERE TO .

ACTION TAKEN: MOTION MADE TO SUSPEND READING AND READ BY TITLE ONLY

BY: Alderman Permenter

SECOND: Alderman Chandler

VOICE VOTES: 7 yeas & 1 nay Absent Alderman Hensen

ACTION TAKEN: MOTION MADE TO SUSPEND READINGS 2 & 3 AND READ BY TITLE ONLY BY:

Alderman Roedel

SECOND: Alderman Higginbotham

VOICE VOTES: 7 yeas & 1 nay Absent Alderman Hensen

ACTION TAKEN: MOTION MADE TO ADOPT BY : Alderman Chandler

SECOND: Alderman Billingsley

ROLL CALL VOTE: 6 yea & 2 nays: Alderman Miller, Alderman Hensen (absent) **PASSED**

- **2015- 5 ORDINANCE TO AMEND ORDINANCE NO 2011-29** AND ESTABLISH RATES FOR SERVICED RENDERED BY THE WATER FACILITIES OF THE WATER AND WASTEWATER SYSTEM OF THE CITY OF BRYANT, AR AND PRESCRIBING OTHER MATTERS RELATING THERETO

ACTION TAKEN: MOTION MADE TO SUSPEND READING AND READ BY TITLE ONLY

BY: Alderman Higginbotham

SECOND: Alderman Permenter

VOICE VOTES: 7 yeas & 1 nays Absent Alderman Hensen **PASSED**

ACTION TAKEN: MOTION MADE TO SUSPEND READINGS 2 & 3 AND READ BY TITLE ONLY

BY: Alderman Roedel

SECOND: Alderman Chandler

VOICE VOTES: 7 yeas & 1 nay Absent Alderman Hensen **PASSED**

ACTION TAKEN: MOTION MADE TO APPROVE BY: Alderman Roedel

Second by: Alderman Chandler

ROLL CALL VOTES: 5 yeas & 3 nays, Alderman Miller, Alderman Permenter and Alderman Hensen - (absent) **PASSED**

PUBLIC COMMENTS

Monty Ledbetter, Director of Public Works, Spoke on Springhill Road, They have \$250, 000 for Springhill Road, The Road will be Repaved and have shoulders on each side . They will be getting bids for the job.

A Retired Sheriff Mr. Campbell has moved to Bryant and has offered his services to help in any way. He has already spoken to Sr. Citizens and is helping them. He has spoken to Chief Kizer to let him know that he will help any way that he may be needed if Chief Kizer ask.

Mary Vickers, Director from Sr. Citizen’s spoke, Letting us know that they will need help serving the home bound meals the third week of March.

Allison Ramsey, Spoke person from the Bryant Chambers, said that the Chambers “Think’s it is time for the City to go ahead and start the "South Route- Route 3- Master Street plan - The Rightaway."

MAYOR COMMENTS

NONE

COUNCIL COMMENTS

NONE

ADJOURNMENT

MOTION MADE TO ADJOURN BY: Alderman Chandler

SECOND: Alderman Roedel

VOICE VOTE: 7 yeas & 1 nay Absent Alderman Hensen **PASSED**

January, 27th, 2015 minutes approved on this day, April 28th 2015

Mayor _____

ATEST
City Clerk _____



City of Bryant Regular Monthly Council Meeting

Tuesday, February 24, 2015 – 7:00 pm

Boswell Municipal Complex – City Hall Courtroom

210 S.W. 3rd Street, Bryant, Ar. 72022

UNOFFICIAL DRAFT

02/24/2015 - Minutes

- CALL TO ORDER

- Mayor Dabbs called the meeting to order at 7 pm.
- INVOCATION BY: Alderman Higginbotham
- PLEDGE: Said with Pride
- Clerk Ashcraft called roll to establish that a quorum was present:
- PRESENT: Alderman Billingsley, Chandler, Gladden, Hensen, Higginbotham, Miller, Permenter,
- ABSENT: Alderman Roedel
- Quorum Present.

- APPROVAL OF MINUTES:

- Approval of December 18th 2014 Regular City Council Minutes

ACTION TAKEN: Alderman Higginbotham made motion to approve and Alderman Permenter Seconded. Voice Vote: 7 yeas & 1 nay (Absent Alderman Roedel)

- January 27th 2015 Regular City Council Minutes.

ACTION TAKEN: Motion made by Alderman Permenter to **table** January 02, 20, 27, 2015 Seconded by Alderman Miller. Voice vote: 6 yeas & 2 nays - Alderman Roedel and Alderman Chandler were absent for this vote.

- ANNOUNCEMENTS AND PRESENTATION

- Mayor Dabbs announced that Brandon Griffin has been named the Parks Director.
- Alderman Miller reminded Citizens that Bryant Spring Cleaning would be in March.
- Mayor Dabbs reminded all citizens that "Keep Bryant Beautiful" Would be in April. Saturday April 18th 2015 Bryant Spring Cleanup event will be At First Southern Baptist Church 604 S Reynolds Rd. From: 7A – 11A 501-776-2533

Alternative Methods for Disposing of Yard Debris in Bryant

- Tiffany Dunn of Saline County Solid Waste Management announced the options available to residents have for yard Debris. There is no charge to take yard cleanup materials to the Landfill. That includes grass clippings, leaves, and limbs. Yard Debris cannot be mixed with trash and will need to be taken out of bags. For questions, call the Scale house: 501-569-3751

AMERICAN HEART MONTH PROCLAMATION

- Mayor Dabbs read the Proclamation Declaring February 24, 2015 as WEAR **RED** DAY for the AMERICAN HEART ASSOCIATION in the City of Bryant.

- COMMITTEE AND COMMISSION REPORT

- Alderman Chandler was in the Water/ Wastewater Regular Monthly Meeting and he reported that the Water Wastewater committee will be coming forth in the future with several options for a future decision on the Water Wastewater developments.

PARKS COMMITTEE APOINTMENT

- Mayor Dabbs announced that Gary Graham has been appointed to the Parks Committee Representing Ward 3.

ACTION TAKEN: Alderman Gladden made motion to approve and Alderman Miller Seconded.
Voice Vote: 7 Yeas & 1 nea (Absent Alderman Roedel)

MAYORS YOUTH ADVISORY COUNCIL Presenting: Dustin Davis

- The youth presented a check for \$100.00. For "DRIVE SMART" Their goal is to STOP youth from being on the cell while driving.

- DEPARTMENT REPORTS

- Department reports are given on a quarterly basis unless otherwise requested.

- PUBLIC COMMENTS

- Scott Curtis Representing the Bryant School system. Is in favor of the Mileage increase. Mr. Curtis asked that the Council support the Mileage increase. Increase of 4.9%, Current mileage is 37.2. Election day is March 10th 2015. Early vote starts Tuesday March 3rd, 2015.
- Executive Pastor Joe Statton of Geyer Springs Baptist Church spoke representing his church. Pastor Statton is in favor of the South Route going in. He is a member of the Economic Development Council. Pastor Statton believes that the "South Route" WILL benefit The Bryant Community.
- Todd Seller, Board member of The Bryant Chambers spoke FOR the South Route and the benefits it will bring Bryant.

- Lamont Cornwell , Director of Cornwell Corp, Member of Economic Development Council, Spoke in FAVOR of the South Route and the benefits it will provide Bryant.
- Josh Cox, Resident of Cherry Circle subdivision, a Fire Fighter, spoke AGAINEST The South Route Road going in. He states that Bryant has roads that need repaired, ie... Springhill Rd.
- Sylvia Adams, Resident living on Johnswood Road Spoke AGAINEST this South Route approval. Miss Adams is not against A South Route going in just NOT this plan. Miss Adams stated that the current route does NOT touch her property. But that it should not tear up people’s homes.
- Halley Robertson a resident of Meadow Lake Drive. Miss Robertson spoke in FAVOR of the South Route Project.
- Dane Pruitt, Mr Pruitt is the Saline County Airport Director. Mr. Pruitt is in FAVOR of the South Route project.
- Rayann Fields spoke as herself and not from the Bryant Chamber. Miss Fields stated that she believes that it is passed time for the South Route
- Cory Pratt a resident living in Ward 2 also has a business in Ward 4 is in FAVOR of the South Route. Said, South Route is growth for our town, along with safety.
- Jeramy Oltham resident since 1980’s is in FAVOR of the South Route plan.
- Annette Ward a resident on Johnswood Road Spoke AGAINEST the South Route plan. This plan will go right thru Miss Wards property. Miss Ward asked Council to think of this as their property as they make the decision to go forward in deciding the South Route Plan.
- Harry Reynolds, a resident of Bryant asked the Council if they found out anything about the \$100,000 plus that is missing? Mayor Dabbs explained that the 2012 audit is complete and that the 2013/2014 audit is on going at this time and is expected to be completed Spring 2015.

- OLD BUSINESS

- NONE

- NEW BUSINESS

1. ANIMAL CONTROL - Presenter: Trisha Powers

- **Approval** to sign-up for PayPal to collect donation online. Via the Shelter Wish List website.

Action taken: Alderman Chandler made motion to approve and Alderman Higginbotham Seconded. Voice Vote: 7 Yeas & 1 nay (Absent Alderman Roedel) **Passed**

- **Approval** to add Training items to the 2015 Budget.

Alderman Higginbotham asked if they had enough funds for this and Trisha Powers stated they DO already have the Funds.

Actions taken: Alderman Higginbotham made motion to approve and Alderman Chandler Seconded.

Voice Vote: 7 yeas & 1 nay (Absent Alderman Roedel) **Passed**

2. FINANCE DEPARTMENT Presenters: Paul Phillips of Crews and Associates, Inc. and Jack Truemper of Stephens Inc.

- **DISCUSSION** REGARDING REFINANCING/REFUNDING OF CERTAIN EXISTING BONDS

A handout was presented re: 2008/2010 Franchise Fee Revenue Bond

NO action was taken at this time this discussion was for informational purposes only.

PRESENTER: - Joy Black

- **PRESENTATION** AND APPROVAL OF THE 2015 JANUARY YEAR TO DATE CITY FINANCIAL REPORT.

Action Taken: Motion made by Alderman Chandler to approve and Alderman Billingsley Seconded.

Voice Vote: 7 yeas & 1 nay (Roedel Absent) **Passed**

- **Resolution** - A Resolution Providing for the Adoption of an Amended Budget for the City of Bryant for the twelve month period beginning January 1, 2015 and ending December 31, 2015.

Action taken: Motion made to Approve by Alderman Billingsley and Seconded by Alderman Miller

Voice Vote: 7 yeas & 1 nay (Roedel Absent) **Passed - Resolution 2015-11**

- **Resolution** - A **RESOLUTION** IN SUPPORT OF PROPOSED LEGISLATION TO REDUCE THE ADMINISTRATION COSTS OF GROSS RECEIPTS TAXES.

Action taken: Motion made to approve by Alderman Miller and Seconded by Alderman Gladden

Voice Vote of 7 yeas & 1 nay (Roedel Absent) **Passed- Resolution 2015-12**

- **Presentation and Approval** of the 2011 A133 Audit_of the Schedule of Expenditures of Federal Awards, Rep and Mgn Letters, and Federal Clearing House Confirmation of Submission.

Action taken: Motion made to approve by Alderman Chandler and Seconded by Alderman Permenter.

Voice Vote of 7 yeas & 1 nay (Alderman Roedel absent) **Passed**

- **Presentation and Approval** of the Arkansas Natural Resources Commission Financial Review of both Water and Wastewater Projects for the period January 1, 2014 through December 31, 2014.

Action taken: Motion made to approve by Alderman Billingsley and Seconded by Alderman Miller

Voice Vote of 7 yeas & 1 nay (Alderman Roedel Absent) **Passed**

- **Resolution** - Resolution in support of the Bryant School District Millage proposal and election on March 10, 2015.

Action Taken: Motion made to approve by Alderman Miller and Seconded by Alderman Higginbotham

Voice Vote of 7 yeas & 1 nay (Alderman Roedel Absent) **Passed - Resolution 2015-13**

- **Ordinance with Emergency Clause** - Ordinance to repeal Ordinance No. 2014-05 Establishing the procedure for the purchasing of property and services in the City of Bryant.

Motion to suspend the rules and read by title only; Motion by Alderman Higginbotham and Seconded by Alderman Billingsley.

Roll Call VOTE: 5 yeas & 3 nays (Voting Nay were: Alderman Miller, Alderman Permenter, and Alderman Roedel-absent). **Failed.** - First Reading - the Ordinance was read aloud.

Motion to suspend the 2nd and 3rd reading and read by title only. Motion by Alderman Higginbotham and Seconded by Alderman Chandler. **Roll Call VOTE:** 6 Yeas & 3 Nays (Voting Nay were: Alderman Miller, Alderman Permenter, Alderman Roedel- absent). Mayor Dabbs exercised the Mayor's right to pass a motion of Council and voted –yea, **Passed.** The Ordinance was read by title only.

Motion to adopt: by Alderman Higginbotham and Seconded by Alderman Hensen. **Roll call VOTE:** 5 yeas & 3 nays (Voting Nay were: Alderman Miller, Alderman Permenter, and Alderman Roedel absent). **Passed – Ordinance No. 2015-06.**

Motion to adopt the emergency clause: by Alderman Chandler and Seconded by Alderman Gladden. **Roll call VOTE:** 5 yeas & 3 nays (Alderman Permenter, Alderman Miller and Alderman Roedel –absent) **FAILED**

- **Resolution** – A Resolution authorizing the Mayor to negotiate for and acquire right-of-way offers from landowners for a south route connecting Interstate 30 with the south side of the City of Bryant. (requested by Council)

Action taken: Motion made to approve by Alderman Billingsley and Seconded by Alderman Hensen. **Roll call Vote:** 5 yeas & 4 nays (Voting Nay were: Alderman Higginbotham, Alderman Miller, Alderman Permenter, and Alderman Roedel – absent) Mayor Dabbs exercised the Mayor's right to pass a motion of Council and voted – Yea. **PASSED - Resolution 2015-14**

Motion to have a Workshop on South Route Options made by Alderman Miller, Seconded by Alderman Higginbotham. **Roll call Vote:** 3 yeas and 5 nays (Voting Nay were: Alderman Billingsley, Alderman Chandler, Alderman Gladden, Alderman Hensen, and Roedel–absent). **Failed**

- **RESOLUTION** - Resolution Authorizing the Mayor to accept donation of real property.

Action taken: Motion made to approve by Alderman Higginbotham and Seconded by Alderman Hensen. Voice Vote of 7 yeas & 1 nay (Alderman Roedel- absent) **Passed - Resolution 2015- 15**

3. **Parks Department** *Presenter - Brandon Griffin, Interim Parks Director*

- **Parks Employee Positions and Restructuring** – Request to Freeze Recreation Superintendent position and open Programmer position.

Action taken: Motion made to approve by Alderman Higginbotham and Seconded by Alderman Permenter. **Voice vote** 7 yea & 1 nay (Alderman Roedel- absent) **Passed.**

- **Membership Promotions - recommended by Parks Committee**

Action taken: Motion made to approve by Alderman Higginbotham and Seconded by Alderman Gladden **Voice vote:** 7 yeas & 1 nay (Alderman Roedel- absent) **Passed**

- **John Deere Lease** - Parks Department has \$30,000.00 budgeted for John Deere leases. This will include the amount that parks purchased last year and will add \$12,000.00 in lease this year. Request to add to lease.

Action taken: Motion made to approve contract by Alderman Chandler and Seconded by Alderman Gladden. Voice vote: 7 yeas & 1 nay (Alderman Roedel- absent) **Passed**

4. Planning Department: *Presenter Dave Green, Planning Director*

- **Ordinance** - Ordinance Changing the Zoning of a Certain Tract of Land from R-E Residential to R-2 Residential.

Motion to suspend the rules and read by title only:

Action taken: Motion made to approve by Alderman Higginbotham and Seconded by Alderman Miller Voice Vote: 7 yeas & 1 nay (Alderman Roedel- absent) Ordinance read by title only.

Motion to suspend the 2nd & 3rd reading and read by title only:

Action taken: Motion made to approve by Alderman Higginbotham and Seconded by Alderman Miller Voice Vote: 7 yeas and 1 nay (Alderman Roedel- absent) Ordinance read by title only.

Motion to ADOPT:

Action taken: Motion made by Alderman Gladden Seconded by Alderman Higginbotham

Roll call vote: 7 yeas and 1 nay (Alderman Roedel- absent). **Passed - Ordinance 2015- 07**

5. Public Works *Presenter: Monty Ledbetter Water/Wastewater*

- **Request Approval to purchase water meters up to \$10,500** (in current budget)

Action taken: Motion made to approve by Alderman Higginbotham and Seconded by Alderman Billingsley. Voice Vote: 7 yeas & 1 nay (Alderman Roedel- absent). **Passed**

- **Ordinance** amending Ordinance No. 2011-28 to establish a minimum "in lieu fee" in the City of Bryant Storm water Management Manual, Section 1000.1.2, paragraph 3.

Action taken: Motion made to TABLE by Alderman Higginbotham and Seconded by Alderman Chandler Voice Vote: 7 yeas and 1 nay (Alderman Roedel- absent) **TABLED until March Meeting pending review by MS4.**

- ADDITIONAL PUBLIC COMMENTS

- Elected City Attorney spoke stating that he needs action taken by the City Council. Mr. Farmer wants to have the job as Elected City Attorney clarified. He stated that the current Ordinance has only four duty's for his job. Reside within the City limits of Bryant, abides by and enforces all city ordinances and laws, prosecutes all city misdemeanor cases and take the oath of office. However Mr. Farmer stated he did not run for the position to do nothing and collect a check. He ran under the impression that the elected City Attorney would be the Chief Legal Officer and would be in charge of the legal department. Mr. Farmer said the City Council has discussed this role since September 2014. Mr. Farmer stated that he proposed an Ordinance in January; it was on the agenda and was tabled. Mr. Farmer asked the Council to take action now, asking the Council to pass an ordinance clarifying the role and responsibility of the Elected City Attorney

stating that the elected City Attorney is the Chief Legal Officer and the leader of Bryant's legal department.

- Mayor Comments:

NONE

- Council Comments:

Alderman Miller commented on December 26, 2014 Holiday pay.

Mayor Dabbs said that the legal staff will look into this for next council meeting.

- Adjournment:

Alderman Chandler made motion to adjourn and Seconded by Alderman Miller.

Motion Carried 7 yeas & 1 nay – Absent Roedel

February 24, 2015 Minutes Approved by the Bryant City Council on April 28, 2015

Mayor _____

ATEST:

City Clerk _____



City of Bryant Regular Monthly Council Meeting

Tuesday, March 31, 2015 – 7:00 pm

Boswell Municipal Complex – City Hall Courtroom

210 S.W. 3rd Street, Bryant, Ar. 72022

UNOFFICIAL DRAFT

March 31, 2015 Minutes

CALL TO ORDER

- Mayor Dabbs called the meeting to order at 7:07pm.
- INVOCATION BY: Aldermen Higginbotham
- PLEDGE: Led by: Liz Cortez (Member of Boys and Girls Club)
- Clerk Ashcraft called roll to establish that a quorum was present.
- PRESENT: Aldermen Billingsley, Chandler, Gladden, Hensen, Higginbotham, Miller, Permenter, Roedel.

APPROVAL OF MINUTES:

- January's and February's minutes were tabled until April.

ACTION TAKEN: Motion made by Alderman Miller to table January's and February's minutes.

SECOND by Alderman Roedel

VOICE VOTE: 8 yeas 0 Nays

COMMITTEE AND COMMISSION REPORTS:

NONE

ANNOUNCEMENTS AND PRESENTATION:

- **Mayor Dabbs delivered the 2015 State of the City Proclamation:**

The following groups received recognition via proclamation from the Mayor:

The Bryant Boys and Girls Club-- National Boys and Girls Club Week

Autism Speaks --Autism Awareness

CASA -- Child Abuse Awareness

Centerpoint --Safe Digging Month

Child Abuse and Neglect Prevention Board- Paint the County Blue

You can hear all Proclamation on audio at the City's web site. (www.cityofbryant.com)

- Bryant Robotic Team: Debbie Norris spoke on behalf of the team. Bryant's Team "WON" the right to compete in a WORLD WIDE competition. They will compete with team such as, China, Europe, Japan and more. So far they have earned \$5,500 toward the trip. Mayor Dabbs drew for the WINNING ticket. BILL COOT is the winner of a 3 night trip to Big Cedar Wilderness in Eureka Springs Ar. A robot demo was given.

- Mr. Paul Phillips of Crews and Associates, Inc. spoke regarding a follow up from the February meeting. Spoke on the issues of Refunds 2008 and 2010 and answered Alderman Millers question from the February meeting.

LEGAL DEPARTMENT: Presenter Staff Attorney Chris Madison

- **Discussion of issue raised concerning December 26, 2014 City Offices being closed.**

Staff Attorney Madison stated that up to eight hours of comp time would be given to the personal that worked that day. Attorney Madison said that no council action would be needed. This will be handled by Administration. No action was taken by Council.

DEPARTMENT REPORTS:

NONE

PUBLIC COMMENTS:

- Ms. Lavern Cole: Miss Cole made a statement that Trash pick up trucks are going too fast and not stopping at red lights.
- Mr. Josh Farmer: Mr. Farmer spoke asking for a workshop for Elected City Attorney position.
- Mr. Phillip Campbell: Mr. Campbell is new in town and was letting the council know that around the Lowe's area the City needed reflectors.

OLD BUSINESS:

NONE

NEW BUSINESS:

FINANCE DEPARTMENT: *Presenter: Joy Black, Finance Director*

- **Presentation and Approval of the 2015 February Year to Date City Financial Report**

Action taken: Motion made by Alderman Miller to TABLE until the April meeting and add this to the April 21st, 2015 Workshop, at 6:00 pm.

SECOND by: Alderman Hensen

Voice Vote: 8 yeas 0 nays

- **A Resolution Providing for the Adoption of an Amended Budget for the City of Bryant for the twelve month period beginning January 1, 2015 and ending December 31, 2015**

Resolution 2015-16

Action taken: Alderman Miller Made a motion to approve.

Second By: Alderman Roedel

Voice Vote: 8 yeas 0 nays

- **A Resolution providing for the Revision of the Uniform Policy for the City of Bryant, replacing any earlier versions in the Employee Handbook.**

Resolution 2015-17

Action Taken: Motion made by Alderman Roedel to approve.

Second by: Alderman Chandler

Voice Vote: 8 yeas 0 nays

- **Presentation and Approval of the 2014 City Reports to be published in the newspaper by April 1, 2015 per State Statutes 14-59-116 (general budget) and 14-237-113 (water/waste water)**

Action Taken: Motion made by Alderman Roedel to approve.

Second by: Alderman Billingsley

Voice Vote: 8 yeas 0 nays

- **Note: Ordinances passed at the March 31, 2015 meeting were given the incorrect numbers on the recording. The minutes have been altered to reflect the actual and correct numbers and each ordinance when executed by the Mayor and City Clerk, have been corrected to accurately and correctly reflect the proper numbers.**

- **Ordinance - to repeal Ordinance No. 2013-14 Dr. L. Douglass Brown Forensic Audit**

Ordinance 2015-8

Motion to suspend the rules and read by title only.

Action Taken: Motion made by Alderman Higginbotham.

Second by: Alderman Chandler

Voice Vote: 6 yeas 2 nays - Alderman Miller & Alderman Hensen

Motion to suspend the 2nd and 3rd reading and read by title only.

Action Taken: Motion made by Alderman Billingsley.

Second by: Alderman Chandler

Voice Vote: 6 yeas 2 nays - Alderman Miller & Alderman Hensen

Motion to Adopt:

Action taken: Action Taken: Motion made by Alderman Permenter to approve.

Second by: Alderman Higginbotham

Roll call Vote: 7 yeas 1 nays - Alderman Miller

- **Resolution authorizing the sale of Surplus equipment, fixtures, and items owned by the City of Bryant.**

Resolution 2015-18

Action taken: Motion made by Alderman Roedel to approve with the correction of changing the MONTH from May to June.

Second by: Alderman Hensen

Voice Vote: 8 yeas 0 nays

Human Resource Department: *Presenter Brandon Griffin, Bryant Parks Director*

- **The Parks Director is requesting council approval for the rewrite and classification of the Office Manager and Aquatics Coordinator position descriptions; Approval of two new positions and classification and compensation plans: Lead Receptionist and Assistant Program Coordinator.**

Action taken: Motion made by Alderman Roedel for approval on all four (4) Resolutions, along with all positions and duties.

Second by: Alderman Hensen

Resolution 2015 – 19 Parks Assistant Program Coordinator

Resolution 2015 – 20 Parks Aquatics Coordinator

Resolution 2015 – 21 Parks Lead Receptionist

Resolution 2015 – 22 Parks Office Manager

Voice Vote: 8 yeas & 0 nays

- **An Ordinance Amending the Comprehensive Zoning Ordinance of the City of Bryant to Rezone a Certain Tract of Property from R-2 to PUD.**

ORDINANCE 2015- 9

Action taken:

Motion to suspend the rules and read by title only:

Motion made by Alderman Chandler.

Second by Alderman Permenter

Voice Vote: 8 yeas & 0 nays

Motion to suspend the 2nd and 3rd reading and read by title only:

Motion made by Alderman Miller to approve.

Second by Alderman Roedel.

Voice Vote: 8 yeas & 0 nays

Motion to Adopt:

Motion made by Alderman Higginbotham to approve.

Second by Alderman Miller

Roll call Vote: 8 yeas & 0 nays

- **An Ordinance to Establish and Lay Off Harper's Landing Municipal Property Owners' Multipurpose Improvement District No. 96 of Bryant, Arkansas, and Declaring an Emergency.** *Presenting: Mr. George Kennedy*

Ordinance 2015-10

Motion to suspend the rules and read by title only:

Motion made by Alderman Higginbotham.

Second by Alderman Roedel.

Voice Vote: 8 yeas & 0 nays

Motion to suspend the 2nd & 3rd reading and read by title only.

Motion made by Alderman Billingsley.

Second by Alderman Permenter.

Voice Vote: 8 yeas & 0 nays

Motion to Adopt:

Motion made by Alderman Miller.

Second by Alderman Roedel.

Roll call Vote: 8 yeas & 0 nays

Emergency Clause:

Motion made to approve by Alderman Roedel.

Second by Alderman Hensen

Roll call Vote: 7 yeas & 1 nay – Alderman Chandler

- **Resolution authorizing the City of Bryant Water and Sewer Department to provide services to Creekside Cottages & Olde Salem Township Sewer Improvement Pre-Annexation Agreement.**

Resolution – 2015-23

Motion made to approve by Alderman Gladden.

Second by Alderman Chandler

Voice Vote: 8 yeas & 0 nays

Legal Department: *Presenter: Lorne Gladden, Alderman*

- **Ordinance Defining the Duties and Responsibilities and Stating the Compensation of the City Attorney—**

Ordinance - Tabled

Action taken: Motion made by Alderman Gladden to TABLE and put on April 9th Workshop, at 6:00 pm.

Second by: Alderman Miller

Roll call Vote: 6 yeas 2 nays - Alderman Chandler and Alderman Hensen

Parks Department: *Presenter: Brandon Griffin, Bryant Parks Director*

- **Discussion of Alcohol Permits at Parks - We would like to discuss the option of soliciting alcohol permits in approved facilities at The Center, as well as other parks facilities in the community. Recommended by Parks Committee.**

Action taken: Alderman Roedel wants a workshop; he has concerns about Mills Park and other Parks with Alcohol.

A workshop will be April 9th. Mayor Dabbs wants to see State Statue and how other parks are handling this to be discussed at the workshop.

- **An Ordinance authorizing a contract for installation of floating fencing at Bishop Park; Waiving Competitive bidding; Declaring an Emergency, And for other purposes.**

Ordinance 2015- 11

Action taken: Motion to suspend the rules and read by title only:

Motion made by: Alderman Higginbotham.

Seconded by: Alderman Hensen

Voice Vote: 8 yeas & 0 nays

Motion to suspend the 2nd and 3rd reading and read by title only:

Motion made by: Alderman Higginbotham.

Seconded by: Alderman Hensen

Voice Vote: 8 yeas & 0 nays

Motion made to Adopt: Motion made to approve by Alderman Roedel.

Second by Alderman Permenter

Roll call Vote: 8 yeas & 0 nays

Emergency Clause:

Motion made by: Alderman Chandler to approve.

Second by: Alderman Miller

Roll call Vote: 8 yeas & 0 nays

Planning and Community Development Department,

Presenter Dave Green, Bryant Planning Director

Public Works Department: *Presenter: Monty Ledbetter, Public Works Director Items 1, 3.*

Presenter: Sarah Giammo, Items 2.

- **Ordinance amending Ordinance No. 2011-28 to establish a minimum "in lieu fee" in the City of Bryant Storm water Management Manual, section 1000.1.2, paragraph 3.**

Ordinance 2015-12

Action taken: Motion to suspend the rules and read by title only:

Motion made by: Alderman Higginbotham to approve.

Seconded by: Alderman Hensen

Voice Vote: 8 yeas & 0 nays

Motion to suspend the 2nd and 3rd reading and read by title only:

Motion made by: Alderman Billingsley to approve.

Seconded by: Alderman Hensen

Voice Vote: 8 yeas & 0 nays

Motion made to Adopt: Motion made to approve by Alderman Roedel.

Second by Alderman Hensen

Roll call Vote: 8 yeas & 0 nays

- **Resolution expressing the willingness of the City of Bryant to utilize Federal-Aid Transportation Alternatives Program Funds.**

Resolution – 2015-24

Motion made to approve by Alderman Billingsley.

Second by Alderman Roedel

Voice Vote: 8 yeas & 0 nays

- **Mayor Comments:**

Traffic issues on Boswell Road - After the City acquire the right away to connect Shef to Prickett then we can ask the school to divert the buses onto Shef and off of Boswell.

- **Council Comments:**

Alderman Chandler spoke to Elected Attorney Josh Farmer, confirming that he read the Ordinance 2005-33 before he ran for office. Alderman Chandler stated that according to that Ordinance Attorney Farmer has not fulfilled his duties toward prosecuting misdemeanors. Alderman Miller commented on the contract with Judge Curtis E. Rickard for prosecuting was made after Attorney Farmer was elected. Alderman Higginbotham asked how much notice Mr. Rickard's contract required to cancel it.

Mayor Dabbs said that she would talk to Administration tomorrow to cancel that contract. Attorney Farmer said he would meet with Judge Rickard tomorrow. No action was taken by the Council.

- **Adjournment:**

Motion made by Alderman Roedel to adjourn.

Second by Alderman Miller

Voice Vote: 8 yeas & 0 nays

Time: 9:44p.m.

March 31st 2015 minutes approved on this day, April 28th 2015

Mayor _____

ATEST

City Clerk _____

THE CITY OF BRYANT, ARKANSAS



CITATION AND PROCLAMATION TO THE CITIZENS OF BRYANT, ARKANSAS

Whereas, historic preservation is an effective tool for managing growth, revitalizing neighborhoods, fostering local pride and maintaining community character while enhancing livability; and

Whereas, historic preservation is relevant for communities across the nation, both urban and rural, and for Americans of all ages, all walks of life and all ethnic backgrounds; and

Whereas, it is important to celebrate the role of history in our lives and the contributions made by dedicated individuals in helping to preserve the tangible aspects of the heritage that has shaped us as a people; and

Whereas, we celebrate each May as National Preservation Month and Arkansas Heritage Month, cosponsored by the City of Bryant, the Arkansas Historic Preservation Program, the Department of Arkansas Heritage and the National Trust for Historic Preservation

Now Therefore I, Jill Dabbs, Mayor of the City of Bryant, Arkansas do hereby recognize the month of May 2015 as National Preservation Month and Arkansas Heritage Month and call upon the people of Bryant to join their fellow citizens across the United States in recognizing and participating in this special observance.

Jill Dabbs, Mayor of Bryant

THE CITY OF BRYANT, ARKANSAS



CITATION AND PROCLAMATION TO THE CITIZENS OF BRYANT, ARKANSAS

Whereas, Relay For Life gives the Citizens of Bryant, Arkansas, the opportunity to Celebrate cancer survivors, Remember loved ones who have lost their fight against cancer and Fight Back with those who are still fighting cancer; and

Whereas, a Survivor Luncheon will be held on April 26 , 2015 in Benton, Saline County, Arkansas to honor Saline County Cancer Survivors and their caregivers; and

Whereas, teams and Survivors will walk or run around the track at C.W. Lewis Stadium, Benton, Saline County, Arkansas beginning Friday, May 1, 2015 at 7:00 p.m. and ending Saturday, May 2, 2015, at 2:00 a.m., trying to keep at least one team member on the track at all times; and

Whereas, Relay For Life is an American Cancer Society event which offers the opportunity for an overnight fun-filled event to celebrate Survivors and fund-raising for research, advocacy, education and patient services programs, through a variety of games, food and entertainment for the entire family; and

Whereas, the overnight event symbolizes the fact that cancer never sleeps, but as the dawn breaks it brings a new day, just as Relay For Life brings hope for a cure for cancer; and

Whereas, after sunset on May 1, 2015, Luminaria, with names of those who have fought against cancer and those who continue their fight with cancer, are lit and will glow through the night as a reminder of the importance of the fight against cancer; and

Whereas, Relay For Life is a tradition to show an entire community's support in the fight against cancer.

Now Therefore, I, Jill Dabbs, Mayor of Bryant, Arkansas, do hereby proclaim April 19, 2015 thru May 2, 2015 as "**Relay for Life of Saline County – Paint Bryant Purple**" in the City of Bryant AR , and urge all citizens to recognize and participate in the event.

Jill Dabbs, Mayor of Bryant

THE CITY OF BRYANT, ARKANSAS



CITATION AND PROCLAMATION TO THE CITIZENS OF BRYANT, ARKANSAS

WHEREAS addressing the complex mental health needs of children, youth, and families today is fundamental to the future of Bryant and Saline County.

WHEREAS the need for comprehensive, coordinated mental health services for children, youth, and families places upon our community a critical responsibility;

WHEREAS it is appropriate that a day should be set apart each year for the direction of our thoughts toward our children's mental health and well-being;

WHEREAS COUNSELING CLINIC, INCORPORATED, through its unique approach to serving children and adolescents, is effectively caring for the mental health needs of children, youth, and families in our community;

NOW, THEREFORE, I, Mayor Jill Dabbs do recognize May as National Mental Health Awareness Month and May 7th as National Children's Mental Health Day. I urge our citizens and all agencies and organizations interested in meeting every child and family's mental health needs to unite on that day in the observance of the importance and necessity of providing mental health services and supports to the people of Bryant Arkansas and Saline County.

Jill Dabbs, Mayor of Bryant

THE CITY OF BRYANT, ARKANSAS



CITATION AND PROCLAMATION TO THE CITIZENS OF BRYANT, ARKANSAS

WHEREAS, Goodwill Industries of Arkansas is celebrating its 88 years of serving Arkansans during 2015; and

WHEREAS, the people of Arkansas believe that work has the power to transform lives through building self-confidence, independence, creativity, trust, and friendships and that everyone deserves a chance to work and to provide for themselves and their families; and

WHEREAS, Goodwill Industries is North America's leading nonprofit provider of education, training, and career services for people with disadvantages, including welfare dependency, homelessness, and lack of education or work experience, as well as those with physical, mental, and emotional disabilities; and

WHEREAS, Since its inception in 1927, the mission of Goodwill Industries of Arkansas has been to assist those who are disabled or face other disadvantaging conditions in reaching their highest potential through training, education, and employment;

NOW THEREFORE BE IT RESOLVED, that I, Jill Dabbs, Mayor of the City of Bryant, do hereby proclaim May 3 through May 9, 2015, as Goodwill Industries Week in the city of Bryant, Arkansas and urge all citizens to recognize and commend Goodwill Industries for its 88 years of dedication to our fellow Arkansans who gain self-sufficiency and hope through the services of Goodwill.

Jill Dabbs, Mayor of Bryant

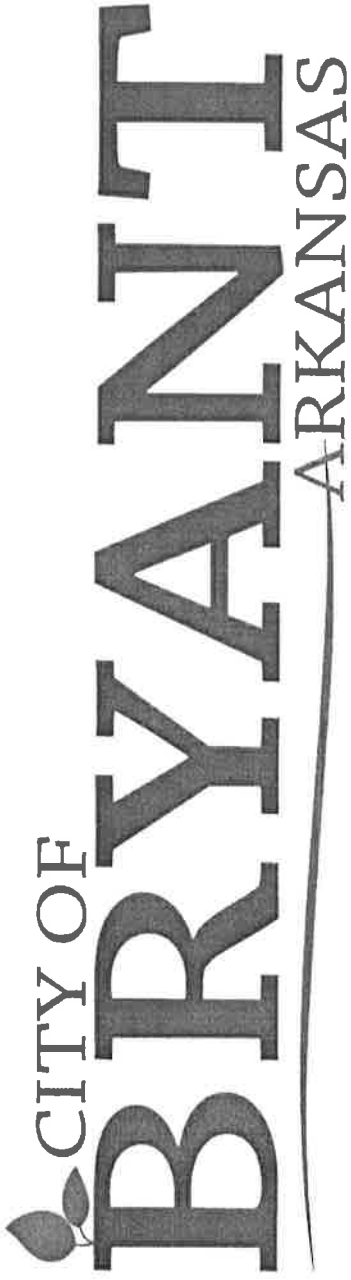

Financial Report

February 2015



General - Executive Summary Revenue & Expenditures

February 2015

	Annual Budget	YTD Budget	Month												Actual YTD Total	YTD Favorable (Unfavorable) Variance	Annual Budget Remaining	
			January	February	March	April	May	June	July	August	September	October	November	December				
Revenues:																		
General	12,059,930	2,009,988	980,810	654,066	-	-	-	-	-	-	-	-	-	-	-	-	(175,113)	10,225,054
Administration	4,986,120	831,020.00	371,926	346,288	-	-	-	-	-	-	-	-	-	-	-	-	(12,809)	4,267,905
PCD	8,100	1,350.00	125	1,137	-	-	-	-	-	-	-	-	-	-	-	-	(66)	6,838
Animal Control	419,000	69,033.33	34,706	34,027	-	-	-	-	-	-	-	-	-	-	-	-	(1,100)	350,266
Court	731,950	121,951.67	94,249	43,718	-	-	-	-	-	-	-	-	-	-	-	-	15,976	593,993
Parks	2,008,450	334,741.67	171,220	148,743	-	-	-	-	-	-	-	-	-	-	-	-	(14,779)	1,688,487
Fire	2,450,000	408,333.33	185,477	185,443	-	-	-	-	-	-	-	-	-	-	-	-	(37,474)	2,079,140
Police	1,299,400	216,566.67	80,000	80,000	-	-	-	-	-	-	-	-	-	-	-	-	(56,567)	1,139,400
Code	156,910	26,151.67	43,167	14,709	-	-	-	-	-	-	-	-	-	-	-	-	31,724	99,034
Total Revenues	12,059,930	2,009,988	980,810	654,066	-	-	-	-	-	-	-	-	-	-	-	-	(175,113)	10,225,054
Expenditures:																		
General	12,077,162	2,012,860	1,203,650	901,337	-	-	-	-	-	-	-	-	-	-	-	-	(92,127)	9,972,174
Administration	950,921	158,486.83	100,928	81,784	-	-	-	-	-	-	-	-	-	-	-	-	(23,624)	768,810
PCD (includes \$25K MS)	252,968	42,161.38	15,896	12,783	-	-	-	-	-	-	-	-	-	-	-	-	13,482	224,289
Animal Control	367,903	61,317.11	30,923	26,628	-	-	-	-	-	-	-	-	-	-	-	-	3,766	370,357
Court	413,009	68,834.75	33,677	28,152	-	-	-	-	-	-	-	-	-	-	-	-	7,006	351,180
Parks	2,309,199	384,866.45	177,193	163,480	-	-	-	-	-	-	-	-	-	-	-	-	(104,451)	1,968,226
Fire	3,417,259	569,543.25	416,402	257,593	-	-	-	-	-	-	-	-	-	-	-	-	(28,918)	3,391,885
Police	4,104,961	684,180.17	402,698	370,378	-	-	-	-	-	-	-	-	-	-	-	-	(3,583)	213,869
Code	260,842	43,480.41	26,934	21,739	-	-	-	-	-	-	-	-	-	-	-	-	(92,127)	9,972,174
Total Expenditures	12,077,162	2,012,860	1,203,650	901,337	-	-	-	-	-	-	-	-	-	-	-	-	(92,127)	9,972,174
Excess (Deficit) of Revenues over Expenditures	(17,232)	(2,872)	(222,841)	(47,271)	-	-	-	-	-	-	-	-	-	-	-	-	(270,112)	

Street - Executive Summary Revenue & Expenditures

	Annual Budget	YTD Budget	Month												Actual YTD Total	Favorable (Unfavorable) Variance	Annual Budget Remaining	
			January	February	March	April	May	June	July	August	September	October	November	December				
Revenues:																		
Street	2,808,100	468,016.67	193,503	184,964	-	-	-	-	-	-	-	-	-	-	-	-	(85,529)	2,429,612
Total Revenues	2,808,100	468,017	193,503	184,964	-	-	-	-	-	-	-	-	-	-	-	-	(85,529)	2,429,612
Expenditures:																		
Street	3,121,818	520,302.92	127,617	108,504	-	-	-	-	-	-	-	-	-	-	-	-	284,192	2,885,697
Total Expenditures	3,121,818	520,303	127,617	108,504	-	-	-	-	-	-	-	-	-	-	-	-	284,192	2,885,697
Excess (Deficit) of Revenues over Expenditures	(313,718)	(52,286)	65,886	76,480	-	-	-	-	-	-	-	-	-	-	-	-	(142,366)	



Water/Wastewater - Executive Summary Revenue & Expenditures

February 2015

Revenues:	Annual Budget	YTD Budget	Month												Actual YTD Total	YTD Favorable (Unfavorable) Variance	Annual Budget Remaining				
			January	February	March	April	May	June	July	August	September	October	November	December							
E50 Sales of Services	7,067,000	1,177,833	516,567	534,887	0	0	0	0	0	0	0	0	0	0	0	0	0	1,051,454	(126,379)	6,015,546	
R60 Miscellaneous Rev	1,000	167	140	140	0	0	0	0	0	0	0	0	0	0	0	0	0	280	113	721	
R62 Intergovernmental	9,065,228	1,510,871	776,792	780,065	0	0	0	0	0	0	0	0	0	0	0	0	0	1,556,857	45,986	7,508,371	
R83 Interest Revenue	0	0	0	0	0	0	0	0	0	0	0	0	0	0	0	0	0	0	0	0	
Total Revenues	16,132,228	2,688,871	1,293,298	1,315,092	0	0	0	0	0	0	0	0	0	0	0	0	0	2,608,250	(90,281)	13,524,637	
Expenditures:																					
E01 Personnel Cost	1,468,258	244,710	141,626	83,166	0	0	0	0	0	0	0	0	0	0	0	0	0	0	0	0	
E10 Building & Ground Exp	432,500	72,083	29,219	31,011	0	0	0	0	0	0	0	0	0	0	0	0	0	224,791	19,918	1,243,467	
E20 Vehicle Expense	147,000	24,500	13,313	5,720	0	0	0	0	0	0	0	0	0	0	0	0	0	60,330	11,754	372,170	
E30 Supply Expense	1,419,590	236,583	72,772	90,170	0	0	0	0	0	0	0	0	0	0	0	0	0	10,033	5,467	127,967	
E40 Operations Expense	483,300	80,530	35,393	18,183	0	0	0	0	0	0	0	0	0	0	0	0	0	162,943	73,641	1,256,537	
E55 Professional Services	101,100	10,850	3,229	7,507	0	0	0	0	0	0	0	0	0	0	0	0	0	53,376	26,974	429,724	
E60 Miscellaneous	130,500	21,750	5,326	0	0	0	0	0	0	0	0	0	0	0	0	0	0	11,036	5,814	90,064	
E62 Intergovernmental	9,564,404	1,594,067	793,920	791,593	0	0	0	0	0	0	0	0	0	0	0	0	0	1,585,213	16,424	125,174	
E64 Reimbursement	0	0	0	0	0	0	0	0	0	0	0	0	0	0	0	0	0	0	0	0	
E72 Bond Expense	1,750,418	291,776	121,041	80,312	0	0	0	0	0	0	0	0	0	0	0	0	0	201,332	90,384	1,349,066	
E80 Fixed Assets	2,916,738	486,126	162	11,908	0	0	0	0	0	0	0	0	0	0	0	0	0	12,070	474,056	2,904,688	
E85 Interest Expense	998,314	165,386	44,297	44,766	0	0	0	0	0	0	0	0	0	0	0	0	0	59,662	167,323	930,232	
Total Expenditures	19,412,052	3,235,242	1,290,697	1,134,336	0	0	0	0	0	0	0	0	0	0	0	0	0	2,395,033	840,309	17,017,018	
Excess (Deficit) of Revenues over Expenditures	(3,279,824)	(546,371)	32,801	180,756	0	0	0	0	0	0	0	0	0	0	0	0	0	213,217			
Assets	(562,660)	(60,344)	32,983	192,664	0	0	0	0	0	0	0	0	0	0	0	0	0	0	225,627		
%	-2%	-2%	3%	15%	0%	0%	0%	0%	0%	0%	0%	0%	0%	0%	0%	0%	0%	9%			

Rev over Exp w/out Fixed

City Sales & Use Tax (Three Cent Sales Tax)

	January	February	March	April	May	June	July	August	September	October	November	December	YTD Total
2014	963,538	1,021,873											1,985,411
2015	902,020	1,162,729											2,064,749
Difference	(61,518)	140,855											79,337

-6%

14%

4%

2014 Actual	1,985,411
Estimated 1%	19,854
2015 Projected	2,005,265
2015 Actual	2,064,749
Short/Over	\$ 59,483

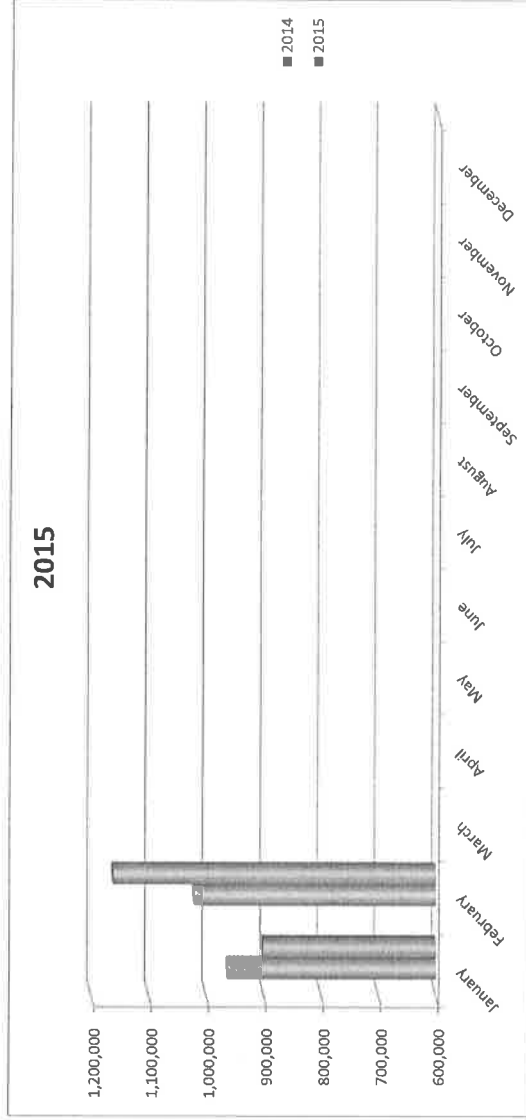



Cash Reserves

February 2015

General Funds:	120 days cash = \$4M	Operating Acct	Days
	001	Designated Tax	2,276,818
	002	Sales Tax Fund	750,698
	003	Franchise Fees	449,341
	060	Police Donation	653,758
	050	Fire Donation	1,756
	045	Park 1/8 Tax	2,653
	055	Fire 3/8 Tax	55,202
	020	Animal Donation	317,600
			10,581
			<u>4,518,406</u>
			136

Street Funds:	120 days cash = \$789k	Operating Acct	1,430,682
	080	CD's	350,000
	080	Designated Tax	657,972
	005		<u>2,438,655</u>
			371
	Alcoa Street Project		<u>(50,000)</u>
	Alcoa Street Project CD		-8
			<u>(350,000)</u>
			-53
			<u>2,038,655</u>
			310

Designated Tax Fund Summary

Administration	\$	80,192
Animal Control	\$	120,972
Parks	\$	4,993
Fire	\$	164,718
Police	\$	379,823
Street	\$	657,972
Total	\$	1,408,670

Springhill Fire Department Summary

Beginning Balance (as of January 1, 2015)	\$	121,887
2015 Revenue (Act 001-0510-4152)	\$	-
2015 Expenses (Act 001-0500-5830)	\$	-
Current Balance (as of October 31, 2014)	\$	121,887



Water Cash Reserves
February 2015

*Reevaluated quarter ending 9/30/14

Water Funds:	500	510	Operating Acct Revenue Fund	3,926,710	2,944,662	6,871,372	750
Reserved - Capital Infrastructure			510-0900-5816	(300,000)			-33
Reserved -Other Equipment			510-0900-5821	(335,000)			-37
Reserved - Misc Capital			510-0900-58XX	(158,000)			-17
Reserved - Snooks Lane Ext			510-0900-5828	(285,000)			-31
Reserved - Dewatering Facility			510-0950-5817	(1,432,758)			-156
Reserved - Capital Infrastructure			510-0950-5816	(300,000)			-33
				4,050,614			443

City of Bryant - Financial Statements
February 2015

	001	002	003	005	020	030	031	045	050	051	055	059	060	061	062	068
	General Fund	Sales Tax Fund	Franchise Fees	Designated Tax Fund	Animal Control Donation	Act 1256 of 1995	Act 1809 of 2001	Park 1/8 Sales Tax O&M	Fire Donation	Act 833 Of 1991	Fire 3/8 Sales Tax	Firemen's Pension	Police Donation	Act 918 of 1983	Act 988 of 1991	State Drug Control
REVENUE																
Taxes - Sales	26,752	387,484	173,227.13					48,447			145,341					
Taxes - Property																
Licenses Permits & Fees	17,165															
Membership Fees	42,293															
Rental Fees	9,884															
Park Program Fees	11,002															
Fines & Forfeitures	43,885					26,623	3,154							1,343	1,081	
Sales of Services	11,897															
Miscellaneous Rev	(22)															
Intergovernmental Reimbursement	688,833			387,576												
Sale of Equipment	0															
Donation Revenue	312				837											
Grant Revenue	0															
Bond Revenue	0															
Sponsorships	1,750															
Interest Revenue	79	15	23	51	0	-	2	2	0	1	11	235	0	1	1	0
Total Revenue	854,066	387,499	173,250	387,627	837	26,623	3,156	48,449	0	1	145,352	235	0	1,344	1,082	0
Expense																
Personnel Cost	697,025															
Building & Ground Exp	66,481															
Vehicle Expense	23,737															
Supply Expense	9,871															
Operations Expense	44,325									624						
Professional Services	24,723															
Miscellaneous	11,734															
Intergovernmental Reimbursement	0	319,583	59,046	313,250			3,721	40,000			105,417					25
Sale of Equipment																
Donation Expense	8,750															
Grant Expense	34															
Bond Expense																
Fixed Assets	14,658															
Interest Expense																
Construction Projects																
Total Expense	901,337	319,583	59,046	313,250	-	26,623	3,721	40,000	-	624	90,759	1,210	-	-	-	25
Change in Fund Balance/Net Position Beginning Fund	(47,271)	67,915	114,204	74,378	837	-	(565)	8,449	0	(623)	54,593	(975)	0	1,344	1,082	(25)
Balance/Net Position Ending Fund	2,324,088	381,426	539,555	1,334,292	9,743	21	59,532	46,753	2,653	30,654	263,007	81,963	1,756	25,825	23,617	8,292
Balance/Net Position	2,276,818	449,341	653,758	1,408,670	10,581	21	58,967	55,202	2,653	30,031	317,600	80,988	1,756	27,168	24,699	8,268

City of Bryant - Financial Statements
February 2015

080	140	141	Park Bond				146	180	181	182	500	510	520	525	530
			Park Bond 2006 DS	Park Bond 2006 DSR	Park Bond 2006 O&M	Park Bond 2007 DS									
REVENUE															
Taxes - Sales	96,894		48,447	96,894											
Taxes - Property	67,380														
Licenses Permits & Fees															
Membership Fees															
Rental Fees															
Park Program Fees															
Fines & Forfeitures															
Sales of Services															
Miscellaneous Rev				0	29,747				29,299	8,365	771,700		14,801		
Intergovernmental															
Reimbursement															
Sale of Equipment															
Donation Revenue															
Grant Revenue															
Bond Revenue															
Sponsorships															
Interest Revenue															
Total Revenue	184,984	96,898	48,447	96,898	29,756	9	3	3	29,305	543,391	771,700		14,826	25	
Expense															
Personnel Cost	67,918														
Building & Ground Exp	4,614														
Vehicle Expense	8,934														
Supply Expense	2,159														
Operations Expense	19,511														
Professional Services	5,368														
Miscellaneous															
Intergovernmental		0	48,447	0						780,954	14,801				
Reimbursement															
Sale of Equipment															
Donation Expense															
Grant Expense															
Bond Expense					236,018				86,263	59,947	20,364				
Fixed Assets											11,908				
Interest Expense		659		830		69		178			14,766				
Construction Projects															
Total Expense	108,504	659	48,447	830	236,018	69	-	178	86,263	840,902	317,279				
Change in Fund															
Balance/Net Position Beginning Fund	76,480	96,898	(659)	96,898	(206,261)	(69)	3	(178)	(56,957)	(297,510)	454,421		14,826		
Balance/Net Position Ending Fund	1,704,202	562,332	262,328	2	568,355	341,086	33,646	176,979	185,087	3,242,172	3,472,289	5	641,326	2	
Balance/Net Position	1,780,682	659,230	261,669	2	665,253	340,256	33,648	176,802	128,130	2,944,662	3,926,710	5	656,152	2	

City of Bryant - Financial Statements
February 2015

	535	540	550	555	560	601	605	610	615	620	Totals
	Impact WW	Fair Share	Impact Water	Impact WW	Salem Royalty	W/WW Bond 2008A DSR	W/WW Bond 2008B DSR	Wolf Creek Debt Ser	WW Bond 2012 Const	Water Bond 2011 Constr	
REVENUE											
Taxes - Sales											
Taxes - Property											
Licenses Permits & Fees											
Membership Fees											
Rental Fees											
Park Program Fees											
Fines & Forfeitures											
Sales of Services											
Miscellaneous Rev			3,000	(40,250)	92	59,947				56,440	
Intergovernmental Reimbursement											
Sale of Equipment											
Donation Revenue											
Grant Revenue											
Bond Revenue											
Sponsorships											
Interest Revenue											
Total Revenue			3,004	(40,245)	93	59,951	0	0	0	56,440	3,924,975
Expense											
Personnel Cost											
Building & Ground Exp											
Vehicle Expense											
Supply Expense											
Operations Expense											
Professional Services											
Miscellaneous					176						
Intergovernmental Reimbursement											
Sale of Equipment											
Donation Expense											
Grant Expense											
Bond Expense											
Fixed Assets											
Interest Expense							380			487	
Construction Projects											
Total Expense					176		380	487			3,396,369
Change in Fund											
Balance/Net Position Beginning Fund			3,004	(40,245)	(83)	59,951	(380)	(486)	0	56,440	528,606
Balance/Net Position Ending Fund	4	2	109,360	179,957	44,088	131,311	159,449	204,961	109	1	17,617,001
Balance/Net Position	4	2	112,364	139,712	44,005	191,262	159,069	204,475	109	56,441	18,145,607

General Ledger

Budget Status

User: emccallum
 Printed: 4/20/2015 - 10:49 AM
 Period: 2, 2015

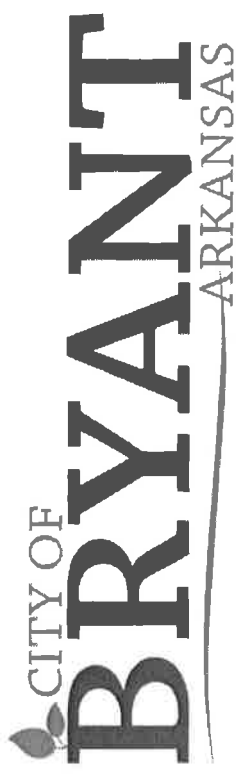

Account Number	Description	Budget Amount	Period Amount	YTD Amount	YTD Var	Encumbered Amount	Available	% Available
Fund 001	General Fund							
Dept 001-0000	Intergovernmental Tsfr							
E62	Xfer to Other	0.00	0.00	0.00	0.00	0.00	0.00	0.00
001-0000-5620	E62 Sub Totals:	0.00	0.00	0.00	0.00	0.00	0.00	0.00
	Expense Sub Totals:							
Dept 0000 Sub Totals:		0.00	0.00	0.00	0.00	0.00		
Dept 001-0100	Administration							
R15	Taxes - Property		18,238.81	53,294.94	191,705.06	0.00	191,705.06	78.25
001-0100-4150	State Turnback	245,000.00	8,487.05	25,287.58	459,712.42	0.00	459,712.42	94.79
001-0100-4151	Saline County Treas - Turnback	485,000.00						
	R15 Sub Totals:	730,000.00	26,725.86	78,582.52	651,417.48	0.00	651,417.48	89.24
R60	Miscellaneous Revenue							
001-0100-4600	Miscellaneous Revenue	1,000.00	-99.95	299.26	700.74	0.00	700.74	70.07
	R60 Sub Totals:	1,000.00	-99.95	299.26	700.74	0.00	700.74	70.07
R62	Intergovernmental Tsfrs							
001-0100-4627	Xfer from Sales Tax	3,835,000.00	319,583.33	639,166.66	3,195,833.34	0.00	3,195,833.34	83.33
001-0100-4629	Xfer Franchise Tax Fd21	420,120.00	0.00	0.00	420,120.00	0.00	420,120.00	100.00
	R62 Sub Totals:	4,255,120.00	319,583.33	639,166.66	3,615,953.34	0.00	3,615,953.34	84.98
R85	Interest Revenue							
001-0100-4850	Interest Revenue	0.00	78.88	166.07	-166.07	0.00	-166.07	0.00
	R85 Sub Totals:	0.00	78.88	166.07	-166.07	0.00	-166.07	0.00
	Revenue Sub Totals:	4,986,120.00	346,288.12	718,214.51	4,267,905.49	0.00	4,267,905.49	85.60
E01	Personnel Expense							
001-0100-5000	Salary Expense	469,904.11	35,655.75	99,732.95	370,171.16	0.00	370,171.16	78.78
001-0100-5001	Elected Officials Salary Exp	175,409.62	13,924.18	32,683.46	142,726.16	0.00	142,726.16	81.37

Account Number	Description	Budget Amount	Period Amount	YTD Amount	YTD Var	Encumbered Amount	Available	% Available
001-0100-5005	SWB Reimbursement	-545,000.00	-4,166.66	-22,333.32	-522,666.68	0.00	-522,666.68	0.00
001-0100-5010	Overtime Expense	10,000.00	262.72	387.90	9,612.10	0.00	9,612.10	96.12
001-0100-5020	FICA Expense	56,797.30	3,807.12	10,100.52	46,696.78	0.00	46,696.78	82.22
001-0100-5022	Unemployment Expense	3,960.00	0.00	50.33	3,909.67	0.00	3,909.67	98.73
001-0100-5025	Worker's Comp Expense	3,500.00	0.00	3,367.34	132.66	0.00	132.66	3.79
001-0100-5030	APERS Expense	102,218.10	6,695.97	17,691.72	84,526.38	0.00	84,526.38	82.69
001-0100-5038	Pension Expense	2,200.00	179.37	358.74	1,841.26	1,614.33	226.93	10.32
001-0100-5040	Health Insurance Expense	84,654.36	6,536.28	14,192.56	70,461.80	0.00	70,461.80	83.23
001-0100-5042	Employee Assistance Program	5,000.00	958.00	1,437.00	3,563.00	0.00	3,563.00	71.26
001-0100-5044	Legal Services Expense	30,000.00	2,500.00	5,000.00	25,000.00	22,500.00	2,500.00	8.33
001-0100-5050	Physical & Drug Screen Exp	600.00	0.00	0.00	600.00	0.00	600.00	100.00
001-0100-5055	Uniform Expense	700.00	174.26	174.26	525.74	0.00	525.74	75.11
001-0100-5057	Vehicle Allowance	8,000.00	461.52	1,153.80	6,846.20	0.00	6,846.20	85.58
001-0100-5060	Travel & Training Expense	12,940.00	398.15	498.15	12,441.85	247.51	12,194.34	94.24
001-0100-5065	First Aid Expense	100.00	0.00	0.00	100.00	0.00	100.00	100.00
E01 Sub Totals:		420,983.49	67,386.66	164,495.41	256,488.08	24,361.84	232,126.24	55.14
E10	Building & Grounds Exp							
001-0100-5102	Repairs & Maint - Building	1,350.00	0.00	0.00	1,350.00	0.00	894.24	66.24
001-0100-5104	Repairs & Maint - Grounds	1,000.00	55.07	55.07	944.93	468.09	476.84	47.68
001-0100-5110	Utilities - Electric	11,000.00	720.00	1,173.70	9,826.30	0.00	9,826.30	89.33
001-0100-5111	Utilities - Gas	1,600.00	229.99	370.09	1,229.91	0.00	1,229.91	76.87
001-0100-5112	Utilities - Water	1,200.00	151.47	223.36	976.64	0.00	976.64	81.39
001-0100-5115	Communication Exp - Telephone	17,500.00	1,148.72	2,308.01	15,191.99	910.93	14,281.06	81.61
001-0100-5116	Communication Exp - Cellular	6,500.00	603.40	1,251.12	5,248.88	8.99	5,239.89	80.61
001-0100-5120	Insurance - Property	2,000.00	0.00	0.00	2,000.00	0.00	2,000.00	100.00
001-0100-5130	Sanitation	2,500.00	86.24	172.48	2,327.52	86.24	2,241.28	89.65
001-0100-5142	Janitorial Supplies - B&G	1,500.00	0.00	75.77	1,424.23	0.00	1,424.23	94.95
E10 Sub Totals:		46,150.00	2,994.89	5,629.60	40,520.40	1,930.01	38,590.39	83.62
E20	Vehicle Expense							
001-0100-5200	Fuel Expense	1,500.00	83.30	149.00	1,351.00	0.00	1,351.00	90.07
001-0100-5225	Insurance Expense - Vehicle	1,000.00	0.00	305.00	695.00	0.00	695.00	69.50
E20 Sub Totals:		2,500.00	83.30	454.00	2,046.00	0.00	2,046.00	81.84
E30	Supply Expense							
001-0100-5061	Training Aids-Administration	500.00	0.00	0.00	500.00	0.00	500.00	100.00
001-0100-5212	Office Equip Purch/Mnt-Admin	1,500.00	0.00	0.00	1,500.00	0.00	1,500.00	100.00
001-0100-5300	Supplies - Office	5,000.00	-49.84	200.79	4,799.21	435.06	4,364.15	87.28
001-0100-5334	Supplies - Volunteer	2,000.00	0.00	0.00	2,000.00	0.00	2,000.00	100.00
001-0100-5350	Postage Expense	3,000.00	0.00	1,728.04	1,271.96	0.00	1,271.96	42.40
E30 Sub Totals:		12,000.00	-49.84	1,928.83	10,071.17	435.06	9,636.11	80.30
E40	Operations Expense							

Account Number	Description	Budget Amount	Period Amount	YTD Amount	YTD Var	Encumbered Amount	Available	% Available
001-0100-5480	Dues & Subscriptions	7,200.00	43.53	43.53	7,156.47	152.00	7,004.47	97.28
001-0100-5481	Municipal/Metro Dues-Admin	55,000.00	175.00	175.00	54,825.00	0.00	54,825.00	99.68
001-0100-5505	Mayor's Expense	5,000.00	0.00	0.00	5,000.00	0.00	5,000.00	100.00
001-0100-5506	City Clerk Expense	2,800.00	0.00	159.42	2,640.58	0.00	2,640.58	94.31
001-0100-5510	Meeting Expense	600.00	0.00	0.00	600.00	0.00	600.00	100.00
	E40 Sub Totals:	70,600.00	218.53	377.95	70,222.05	152.00	70,070.05	99.25
E55	Professional Services							
001-0100-5553	Prof Services - Advertising	7,500.00	156.60	156.60	7,343.40	454.44	6,888.96	91.85
001-0100-5583	Prof Services - Legal	24,000.00	810.00	1,010.00	22,990.00	0.00	22,990.00	95.79
001-0100-5586	Prof. Services - Other	33,000.00	0.00	216.59	32,783.41	0.00	32,783.41	99.34
001-0100-5588	Prof Services - Legal Notices	2,500.00	0.00	0.00	2,500.00	1,483.20	1,016.80	40.67
001-0100-5589	Prof Services - Printing	5,000.00	970.41	970.41	4,029.59	305.10	3,724.49	74.49
	E55 Sub Totals:	72,000.00	1,937.01	2,353.60	69,646.40	2,242.74	67,403.66	93.62
E60	Miscellaneous Expense							
001-0100-5062	Travel & Training - Mayor	3,500.00	659.00	659.00	2,841.00	0.00	2,841.00	81.17
001-0100-5063	Travel & Training - City Clerk	3,325.00	0.00	0.00	3,325.00	315.76	3,009.24	90.50
001-0100-5101	Misc. Expense-Admin	500.00	406.44	406.44	93.56	13.61	79.95	15.99
001-0100-5600	Miscellaneous Expense	100.00	0.00	0.00	100.00	0.00	100.00	100.00
	E60 Sub Totals:	7,425.00	1,065.44	1,065.44	6,359.56	329.37	6,030.19	81.21
E64	Reimbursement							
001-0100-5146	Building & Ground Reim. Court	-24,605.00	0.00	0.00	-24,605.00	0.00	-24,605.00	0.00
001-0100-5147	Building & Grounds Reim PC & D	-7,030.00	0.00	0.00	-7,030.00	0.00	-7,030.00	0.00
001-0100-5148	Building & Ground Reim-Water	-7,030.00	0.00	0.00	-7,030.00	0.00	-7,030.00	0.00
	E64 Sub Totals:	-38,665.00	0.00	0.00	-38,665.00	0.00	-38,665.00	0.00
E68	Donation Expense							
001-0100-5680	Boys and Girls Club Contract	35,000.00	0.00	0.00	35,000.00	0.00	35,000.00	100.00
001-0100-5681	Sr. Adults Contract	20,000.00	0.00	0.00	20,000.00	0.00	20,000.00	100.00
001-0100-5682	Historic Society Contract	10,000.00	0.00	0.00	10,000.00	0.00	10,000.00	100.00
	E68 Sub Totals:	65,000.00	0.00	0.00	65,000.00	0.00	65,000.00	100.00
E80	Fixed Assets							
001-0100-5816	Fixed Asse2011 Ridg Prop Aquis	37,451.78	0.00	0.00	37,451.78	0.00	37,451.78	100.00
	E80 Sub Totals:	37,451.78	0.00	0.00	37,451.78	0.00	37,451.78	100.00
E85	Interest Expense							
001-0100-5850	Interest Expense	2,497.70	0.00	0.00	2,497.70	0.00	2,497.70	100.00
	E85 Sub Totals:	2,497.70	0.00	0.00	2,497.70	0.00	2,497.70	100.00

Account Number	Description	Budget Amount	Period Amount	YTD Amount	YTD Var	Encumbered Amount	Available	% Available
	Expense Sub Totals:	697,942.97	73,635.99	176,304.83	521,638.14	29,451.02	492,187.12	70.52
	Dept 0100 Sub Totals:	-4,288,177.03	-272,652.13	-541,909.68	3,746,267.35	29,451.02		
Dept 001-0110	Miscellaneous Expense							
E60	Computer Hardware	49,458.00	40.75	40.75	49,417.25	0.00	49,417.25	99.92
001-0110-5604	Computer Maint & Support	125,120.00	7,506.91	4,192.30	120,927.70	7,500.00	113,427.70	90.66
001-0110-5608	Computer Software	37,300.00	0.00	0.00	37,300.00	0.00	37,300.00	100.00
001-0110-5610	Website Expense	6,500.00	0.00	0.00	6,500.00	0.00	6,500.00	100.00
001-0110-5612	Tools - IT	1,000.00	0.00	0.00	1,000.00	0.00	1,000.00	100.00
001-0110-5614	Copier Maint & Lease	33,600.00	0.00	1,573.28	32,026.72	20,044.94	11,981.78	35.66
	E60 Sub Totals:	252,978.00	7,547.66	5,806.33	247,171.67	27,544.94	219,626.73	86.82
	Expense Sub Totals:	252,978.00	7,547.66	5,806.33	247,171.67	27,544.94	219,626.73	86.82
	Dept 0110 Sub Totals:	252,978.00	7,547.66	5,806.33	247,171.67	27,544.94	219,626.73	86.82
Dept 001-0120	Licenses Permits & Fees							
R20	Annex/Rezoning Fees	1,000.00	-25.00	100.00	900.00	0.00	900.00	90.00
001-0120-4206	Subdivision Plat & Filing Fees	7,000.00	1,162.00	1,162.00	5,838.00	0.00	5,838.00	83.40
001-0120-4250								
	R20 Sub Totals:	8,000.00	1,137.00	1,262.00	6,738.00	0.00	6,738.00	84.23
R50	Sale of Services							
001-0120-4538	Plotter Copies - PC Dev	100.00	0.00	0.00	100.00	0.00	100.00	100.00
	R50 Sub Totals:	100.00	0.00	0.00	100.00	0.00	100.00	100.00
	Revenue Sub Totals:	8,100.00	1,137.00	1,262.00	6,838.00	0.00	6,838.00	84.42
E01	Personnel Expense							
001-0120-5000	Salary Expense	98,243.72	7,445.60	18,196.16	80,047.56	0.00	80,047.56	81.48
001-0120-5010	Overtime Expense	500.00	0.00	0.00	500.00	0.00	500.00	100.00
001-0120-5020	FICA Expense	7,553.89	559.32	1,368.77	6,185.12	0.00	6,185.12	81.88
001-0120-5022	Unemployment Expense	720.00	0.00	0.00	720.00	0.00	720.00	100.00
001-0120-5025	Worker's Comp Expense	500.00	0.00	228.82	271.18	0.00	271.18	54.24
001-0120-5030	APERS Expense	12,862.82	966.12	2,420.05	10,442.77	0.00	10,442.77	81.19
001-0120-5040	Health Insurance Expense	13,587.84	1,132.32	2,344.64	11,243.20	0.00	11,243.20	82.74
001-0120-5050	Physical & Drug Screen Exp	150.00	0.00	0.00	150.00	0.00	150.00	100.00
001-0120-5060	Travel & Training Expense	1,000.00	0.00	0.00	1,000.00	0.00	1,000.00	100.00
	E01 Sub Totals:	135,118.27	10,103.36	24,558.44	110,559.83	0.00	110,559.83	81.82
E10	Building & Grounds Exp							

Account Number	Description	Budget Amount	Period Amount	YTD Amount	YTD Var	Encumbered Amount	Available	% Available
001-0120-5100	Building & Grounds Reim	5,530.00	0.00	0.00	5,530.00	0.00	5,530.00	100.00
001-0120-5110	Utilities - Electric	1,400.00	0.00	113.42	1,286.58	0.00	1,286.58	91.90
001-0120-5111	Utilities - Gas	500.00	57.49	92.51	407.49	0.00	407.49	81.50
001-0120-5113	Utilities-Water	0.00	13.53	13.53	-13.53	0.00	-13.53	0.00
001-0120-5115	Communication Exp - Telephone	2,100.00	160.74	321.48	1,778.52	0.00	1,778.52	84.69
001-0120-5116	Communication Exp - Cellular	1,400.00	55.96	127.84	1,272.16	0.00	1,272.16	90.87
001-0120-5130	Sanitation - Planning	300.00	21.56	43.14	256.86	0.00	256.86	85.62
E10 Sub Totals:		11,230.00	309.28	711.92	10,518.08	0.00	10,518.08	93.66
E30	Supply Expense							
001-0120-5300	Supplies - Office	1,500.00	0.00	0.00	1,500.00	0.00	1,500.00	100.00
001-0120-5350	Postage Expense	1,000.00	0.00	0.00	1,000.00	0.00	1,000.00	100.00
E30 Sub Totals:		2,500.00	0.00	0.00	2,500.00	0.00	2,500.00	100.00
E40	Operations Expense							
001-0120-5480	Dues & Subscriptions	49,000.00	1,454.66	1,454.66	47,545.34	0.00	47,545.34	97.03
001-0120-5510	Meeting Expense	100.00	0.00	0.00	100.00	0.00	100.00	100.00
E40 Sub Totals:		49,100.00	1,454.66	1,454.66	47,645.34	0.00	47,645.34	97.04
E55	Professional Services							
001-0120-5553	Prof Services - Advertising	2,000.00	0.00	0.00	2,000.00	323.80	1,676.20	83.81
001-0120-5571	Prof Services - Engineering	12,240.00	1,020.00	1,870.17	10,369.83	0.00	10,369.83	84.72
001-0120-5574	Prof Services - GIS	6,120.00	0.00	0.00	6,120.00	0.00	6,120.00	100.00
001-0120-5589	Prof Services - Printing	350.00	50.00	50.00	300.00	0.00	300.00	85.71
E55 Sub Totals:		20,710.00	1,070.00	1,920.17	18,789.83	323.80	18,466.03	89.16
E60	Miscellaneous Expense							
001-0120-5608	Computer Software	7,310.00	0.00	0.00	7,310.00	0.00	7,310.00	100.00
E60 Sub Totals:		7,310.00	0.00	0.00	7,310.00	0.00	7,310.00	100.00
E70	Grant Expense							
001-0120-5610	Grant Exp - Jump Start	2,000.00	33.89	33.89	1,966.11	0.00	1,966.11	98.31
E70 Sub Totals:		2,000.00	33.89	33.89	1,966.11	0.00	1,966.11	98.31
Expense Sub Totals:		227,968.27	12,971.19	28,679.08	199,289.19	323.80	198,965.39	87.28
Dept 0120 Sub Totals:		219,868.27	11,834.19	27,417.08	192,451.19	323.80		
E01	Personnel Expense							
001-0140-5025	Worker's Comp Expense	0.00	-188.22	0.00	0.00	0.00	0.00	0.00
E01 Sub Totals:		0.00	-188.22	0.00	0.00	0.00	0.00	0.00

Account Number	Description	Budget Amount	Period Amount	YTD Amount	YTD Var	Encumbered Amount	Available	% Available
E90	Construction Projects							
001-0140-5901	Project - Forest Cove Grant Pr	25,000.00	0.00	0.00	25,000.00	0.00	25,000.00	100.00
	E90 Sub Totals:	25,000.00	0.00	0.00	25,000.00	0.00	25,000.00	100.00
	Expense Sub Totals:	25,000.00	-188.22	0.00	25,000.00	0.00	25,000.00	100.00
	Dept 0140 Sub Totals:	25,000.00	-188.22	0.00	25,000.00	0.00		
Dept 001-0200								
R20	Licenses Permits & Fees							
001-0200-4202	Adoption Revenue	4,000.00	140.00	425.00	3,575.00	0.00	3,575.00	89.38
001-0200-4222	Misc Revenue - Animal Control	10,000.00	315.00	1,089.45	8,910.55	0.00	8,910.55	89.11
001-0200-4224	Dog License Fee	3,000.00	318.50	373.50	2,626.50	0.00	2,626.50	87.55
001-0200-4246	Spay & Neuter Revenue	13,000.00	780.00	1,980.00	11,020.00	0.00	11,020.00	84.77
	R20 Sub Totals:	30,000.00	1,553.50	3,867.95	26,132.05	0.00	26,132.05	87.11
R40	Fines & Forfeitures							
001-0200-4420	Animal Control Fines	6,000.00	245.00	695.00	5,305.00	0.00	5,305.00	88.42
	R40 Sub Totals:	6,000.00	245.00	695.00	5,305.00	0.00	5,305.00	88.42
R62	Intergovernmental Tsfrs							
001-0200-4627	Xfer Designated Tax	383,000.00	31,916.66	63,833.32	319,166.68	0.00	319,166.68	83.33
	R62 Sub Totals:	383,000.00	31,916.66	63,833.32	319,166.68	0.00	319,166.68	83.33
R68	Donation Revenue							
001-0200-4680	Donation - Animal Shelter	0.00	292.25	317.25	-317.25	0.00	-317.25	0.00
001-0200-4682	Donation - Dog Park	0.00	20.00	20.00	-20.00	0.00	-20.00	0.00
	R68 Sub Totals:	0.00	312.25	337.25	-337.25	0.00	-337.25	0.00
	Revenue Sub Totals:	419,000.00	34,027.41	68,733.52	350,266.48	0.00	350,266.48	83.60
E01	Personnel Expense							
001-0200-5000	Salary Expense	151,540.54	11,388.10	28,362.95	123,177.59	0.00	123,177.59	81.28
001-0200-5005	SWB Reimbursement	43,600.00	3,633.33	7,266.66	36,333.34	0.00	36,333.34	83.33
001-0200-5010	Overtime Expense	11,000.00	794.03	2,465.41	8,534.59	0.00	8,534.59	77.59
001-0200-5020	FICA Expense	12,740.16	904.65	2,301.67	10,438.49	0.00	10,438.49	81.93
001-0200-5022	Unemployment Expense	2,147.84	0.00	66.43	2,081.41	0.00	2,081.41	96.91
001-0200-5025	Worker's Comp Expense	500.00	0.00	172.29	327.71	0.00	327.71	65.54
001-0200-5030	APERS Expense	23,888.44	1,798.10	4,550.31	19,338.13	0.00	19,338.13	80.95
001-0200-5040	Health Insurance Expense	37,206.68	2,650.96	5,008.92	32,197.76	0.00	32,197.76	86.54
001-0200-5050	Physical & Drug Screen Exp	450.00	0.00	0.00	450.00	0.00	450.00	100.00
001-0200-5055	Uniform Expense	2,500.00	644.32	644.32	1,855.68	75.48	1,780.20	71.21
001-0200-5060	Travel & Training Expense	3,355.00	0.00	0.00	3,355.00	0.00	3,355.00	100.00

Account Number	Description	Budget Amount	Period Amount	YTD Amount	YTD Var	Encumbered Amount	Available	% Available
001-0200-5065	First Aid Expense	500.00	0.00	0.00	500.00	0.00	500.00	100.00
E01 Sub Totals:		289,428.66	21,813.49	50,838.96	238,589.70	75.48	238,514.22	82.41
E10	Building & Grounds Exp							
001-0200-5102	Repairs & Maint - Building	2,000.00	0.00	0.00	2,000.00	0.00	2,000.00	100.00
001-0200-5104	Repairs & Maint - Grounds	2,000.00	0.00	0.00	2,000.00	0.00	2,000.00	100.00
001-0200-5110	Utilities - Electric	8,000.00	872.99	2,003.60	5,996.40	0.00	5,996.40	74.96
001-0200-5111	Utilities - Gas	500.00	0.00	51.50	448.50	118.89	329.61	65.92
001-0200-5112	Utilities - Water	800.00	115.02	177.51	622.49	-60.25	682.74	85.34
001-0200-5115	Communication Exp - Telephone	5,500.00	988.28	988.28	4,511.72	618.63	3,893.09	70.78
001-0200-5120	Insurance - Property	1,200.00	0.00	0.00	1,200.00	0.00	1,200.00	100.00
001-0200-5125	Alarm	800.00	63.50	63.50	736.50	63.50	673.00	84.13
001-0200-5130	Sanitation	1,500.00	125.41	250.82	1,249.18	0.00	1,249.18	83.28
001-0200-5140	Supplies - B&G	500.00	0.00	0.00	500.00	22.93	477.07	95.41
001-0200-5145	Tools	1,200.00	5.45	5.45	1,194.55	286.22	908.33	75.69
E10 Sub Totals:		24,000.00	2,170.65	3,540.66	20,459.34	1,049.92	19,409.42	80.87
E20	Vehicle Expense							
001-0200-5200	Fuel Expense	8,999.00	327.30	656.37	8,342.63	0.00	8,342.63	92.71
001-0200-5210	Service & Repair - Vehicle	2,000.00	15.50	15.50	1,984.50	95.06	1,889.44	94.47
001-0200-5212	Service & Repair - Equipment	200.00	0.00	0.00	200.00	0.00	200.00	100.00
001-0200-5213	Equipment Repairs - Tires	1,000.00	0.00	0.00	1,000.00	0.00	1,000.00	100.00
001-0200-5225	Insurance Expense - Vehicle	1,065.00	0.00	1,061.39	3.61	0.00	3.61	0.34
E20 Sub Totals:		13,264.00	342.80	1,733.26	11,530.74	95.06	11,435.68	86.22
E30	Supply Expense							
001-0200-5300	Supplies - Office	500.00	0.00	0.00	500.00	240.79	259.21	51.84
001-0200-5302	Supplies - Kitchen	200.00	8.34	8.34	191.66	0.00	191.66	95.83
001-0200-5306	Supplies - Food Allowance	1,500.00	79.98	79.98	1,420.02	71.01	1,349.01	89.93
001-0200-5322	Supplies - Operating	3,300.00	43.64	43.64	3,256.36	0.00	3,256.36	98.68
001-0200-5350	Postage Expense	100.00	0.00	0.00	100.00	0.00	100.00	100.00
001-0200-5370	Medicine Expense	4,000.00	186.14	186.14	3,813.86	41.07	3,772.79	94.32
001-0200-5371	Spay & Neuter Vouchers	2,000.00	60.00	-345.00	2,345.00	420.00	1,925.00	96.25
E30 Sub Totals:		11,600.00	378.10	-26.90	11,626.90	772.87	10,854.03	93.57
E40	Operations Expense							
001-0200-5116	Communication Exp - Cellular	3,300.00	263.84	531.36	2,768.64	0.00	2,768.64	83.90
001-0200-5141	Pest/Chem/Seed/Fert	1,000.00	82.13	164.26	835.74	0.00	835.74	83.57
001-0200-5142	Janitorial Supplies	3,000.00	186.07	186.07	2,813.93	67.54	2,746.39	91.55
001-0200-5323	Material and Maint.	200.00	0.00	0.00	200.00	0.00	200.00	100.00
001-0200-5480	Dues & Subscriptions	900.00	43.57	243.05	656.95	0.00	656.95	72.99
001-0200-5593	Animal Care Charges	2,300.00	0.00	0.00	2,300.00	36.90	2,263.10	98.40
001-0200-5608	Computer Software	310.00	0.00	0.00	310.00	0.00	310.00	100.00

Account Number	Description	Budget Amount	Period Amount	YTD Amount	YTD Var	Encumbered Amount	Available	% Available
E40 Sub Totals:		11,010.00	575.61	1,124.74	9,885.26	104.44	9,780.82	88.84
E55	Professional Services							
001-0200-5061	Marketing Expense	500.00	0.00	0.00	500.00	0.00	500.00	100.00
001-0200-5553	Prof Services - Advertising	0.00	0.00	0.00	0.00	0.00	0.00	0.00
001-0200-5577	Prof Services - Incineration & Disp	3,000.00	32.75	32.75	2,967.25	668.39	2,298.86	76.63
001-0200-5589	Prof Services - Printing	500.00	70.00	70.00	430.00	23.72	406.28	81.26
001-0200-5592	Prof Services - Veterinarian	14,500.00	1,173.00	153.00	14,347.00	1,475.00	12,872.00	88.77
E55 Sub Totals:		18,500.00	1,275.75	255.75	18,244.25	2,167.11	16,077.14	86.90
E60	Miscellaneous Expense							
001-0200-5600	Miscellaneous Expense	100.00	71.97	84.87	15.13	0.00	15.13	15.13
E60 Sub Totals:		100.00	71.97	84.87	15.13	0.00	15.13	15.13
E80	Fixed Assets							
001-0200-5803	Fixed Assets - A/C	0.00	0.00	0.00	0.00	0.00	0.00	0.00
E80 Sub Totals:		0.00	0.00	0.00	0.00	0.00	0.00	0.00
Expense Sub Totals:		367,902.66	26,628.37	57,551.34	310,351.32	4,264.88	306,086.44	83.20
Dept 0200 Sub Totals:		-51,097.34	-7,399.04	-11,182.18	-39,915.16	4,264.88		
R40	Fines & Forfeitures							
001-0300-4400	Act 316 of 1991 Revenue	200.00	18.12	35.92	164.08	0.00	164.08	82.04
001-0300-4412	City Attorney Reim	26,000.00	2,190.68	4,342.62	21,657.38	0.00	21,657.38	83.30
001-0300-4414	Court Fines	450,000.00	33,278.60	72,051.16	377,948.84	0.00	377,948.84	83.99
001-0300-4416	District Court Reim	10,000.00	1,181.04	2,341.20	7,658.80	0.00	7,658.80	76.59
001-0300-4424	Judge Retirement Reim	5,200.00	394.84	782.70	4,417.30	0.00	4,417.30	84.95
001-0300-4426	Ordinance 89-15 Revenue	20,000.00	1,966.60	3,898.43	16,101.57	0.00	16,101.57	80.51
001-0300-4428	Warrant Fees	40,000.00	4,610.50	11,749.50	28,250.50	0.00	28,250.50	70.63
R40 Sub Totals:		551,400.00	43,640.38	95,201.53	456,198.47	0.00	456,198.47	82.73
R60	Miscellaneous Revenue							
001-0300-4422	Intoximeter Revenue	550.00	67.14	133.09	416.91	0.00	416.91	75.80
001-0300-4600	Miscellaneous Revenue	0.00	10.57	23.56	-23.56	0.00	-23.56	0.00
R60 Sub Totals:		550.00	77.71	156.65	393.35	0.00	393.35	71.52
R64	Reimbursement							
001-0300-4640	Saline County	180,000.00	0.00	42,609.19	137,390.81	0.00	137,390.81	76.33
R64 Sub Totals:		180,000.00	0.00	42,609.19	137,390.81	0.00	137,390.81	76.33

Account Number	Description	Budget Amount	Period Amount	YTD Amount	YTD Var	Encumbered Amount	Available	% Available
E01	Revenue Sub Totals:	731,950.00	43,718.09	137,967.37	593,982.63	0.00	593,982.63	81.15
	Personnel Expense							
001-0300-5000	Salary Expense	211,109.40	14,557.36	36,083.78	175,025.62	0.00	175,025.62	82.91
001-0300-5010	Overtime Expense	500.00	0.00	0.00	500.00	0.00	500.00	100.00
001-0300-5020	FICA Expense	16,188.12	1,097.54	2,725.05	13,463.07	0.00	13,463.07	83.17
001-0300-5022	Unemployment Expense	2,520.00	0.00	0.00	2,520.00	0.00	2,520.00	100.00
001-0300-5025	Worker's Comp Expense	500.00	0.00	493.84	6.16	0.00	6.16	1.23
001-0300-5030	APERS Expense	31,487.08	2,148.67	5,325.98	26,161.10	0.00	26,161.10	83.09
001-0300-5038	Pension Expense-Judge Rtmnt	11,500.00	0.00	0.00	11,500.00	0.00	11,500.00	100.00
001-0300-5040	Health Insurance Expense	35,967.84	3,010.64	6,101.28	29,866.56	0.00	29,866.56	83.04
001-0300-5050	Physical & Drug Screen Exp	750.00	0.00	0.00	750.00	0.00	750.00	100.00
001-0300-5055	Uniform Expense	490.00	0.00	0.00	490.00	0.00	490.00	100.00
001-0300-5060	Travel & Training Expense	9,391.06	0.00	0.00	9,391.06	0.00	9,391.06	100.00
001-0300-5070	Judge - Share to State	30,000.00	2,405.18	4,810.36	25,189.64	9,620.71	15,568.93	51.90
	E01 Sub Totals:	350,403.50	23,219.39	55,540.29	294,863.21	9,620.71	285,242.50	81.40
E10	Building & Grounds Exp							
001-0300-5102	Repairs & Maint - Building	10,915.00	596.08	596.08	10,318.92	57.84	10,261.08	94.01
001-0300-5103	Office Equipm/Maintenance	1,000.00	0.00	0.00	1,000.00	0.00	1,000.00	100.00
001-0300-5110	Utilities - Electric	6,130.00	0.00	453.70	5,676.30	0.00	5,676.30	92.60
001-0300-5111	Utilities - Gas	1,275.00	229.99	370.09	904.91	0.00	904.91	70.97
001-0300-5112	Utilities - Water	770.00	109.86	157.28	612.72	-54.93	667.65	86.71
001-0300-5115	Communication Exp - Telephone	4,000.00	428.64	857.28	3,142.72	0.00	3,142.72	78.57
001-0300-5130	Sanitation	865.00	86.24	172.48	692.52	0.00	692.52	80.06
	E10 Sub Totals:	24,955.00	1,450.81	2,606.91	22,348.09	2.91	22,345.18	89.54
E30	Supply Expense							
001-0300-5300	Supplies - Office	6,000.00	166.66	166.66	5,833.34	0.00	5,833.34	97.22
001-0300-5350	Postage Expense	1,000.00	0.00	0.00	1,000.00	0.00	1,000.00	100.00
	E30 Sub Totals:	7,000.00	166.66	166.66	6,833.34	0.00	6,833.34	97.62
E40	Operations Expense							
001-0300-5142	Janitorial Supplies	650.00	0.00	0.00	650.00	0.00	650.00	100.00
001-0300-5480	Dues & Subscriptions	3,000.00	763.28	963.28	2,036.72	0.00	2,036.72	67.89
001-0300-5608	Computer Software	20,000.00	2,340.00	2,340.00	17,660.00	11,700.00	5,960.00	29.80
	E40 Sub Totals:	23,650.00	3,103.28	3,303.28	20,346.72	11,700.00	8,646.72	36.56
E55	Professional Services							
001-0300-5553	Prof Services - Advertising	500.00	0.00	0.00	500.00	0.00	500.00	100.00
001-0300-5589	Prof Services - Printing	3,000.00	0.00	0.00	3,000.00	0.00	3,000.00	100.00
	E55 Sub Totals:	3,500.00	0.00	0.00	3,500.00	0.00	3,500.00	100.00

Account Number	Description	Budget Amount	Period Amount	YTD Amount	YTD Var	Encumbered Amount	Available	% Available
E60	Miscellaneous Expense							
001-0300-5606	Computer Maint & Support	500.00	0.00	0.00	500.00	0.00	500.00	100.00
001-0300-5614	Copier Maint & Lease	3,000.00	2,111.79	2,111.79	2,788.21	666.98	2,121.23	70.71
	E60 Sub Totals:	3,500.00	2,111.79	2,111.79	3,288.21	666.98	2,621.23	74.89
	Expense Sub Totals:	413,008.50	28,151.93	61,828.93	351,179.57	21,990.60	329,188.97	79.71
Dept 001-0400	Dept 0300 Sub Totals:	-318,941.50	-15,566.16	-76,138.44	-242,803.06	21,990.60		
R62	Parks General							
001-0400-4627	Intergovernmental Tsfrs	383,000.00	31,916.66	63,833.32	319,166.68	0.00	319,166.68	83.33
001-0400-4629	Xfer Designated Tax	480,000.00	40,000.00	80,000.00	400,000.00	0.00	400,000.00	83.33
	Xfer Park 1/8 O & M							
	R62 Sub Totals:	863,000.00	71,916.66	143,833.32	719,166.68	0.00	719,166.68	83.33
	Revenue Sub Totals:	863,000.00	71,916.66	143,833.32	719,166.68	0.00	719,166.68	83.33
E01	Personnel Expense							
001-0400-5000	Salary Expense	238,602.55	21,218.21	48,473.50	190,129.05	0.00	190,129.05	79.68
001-0400-5001	Park General - Part Time Labor	47,000.00	877.27	2,033.98	44,966.02	0.00	44,966.02	95.67
001-0400-5005	SWB Reimbursement	174,400.00	14,533.33	29,066.66	145,333.34	0.00	145,333.34	83.33
001-0400-5010	Overtime Expense	15,000.00	65.10	111.71	14,888.29	0.00	14,888.29	99.26
001-0400-5020	FICA Expense	23,412.00	1,689.64	3,884.19	19,527.81	0.00	19,527.81	83.41
001-0400-5022	Unemployment Expense	4,445.07	0.00	109.46	4,335.61	0.00	4,335.61	97.54
001-0400-5025	Worker's Comp Expense	7,000.00	0.00	6,929.66	70.34	0.00	70.34	1.00
001-0400-5030	APERS Expense	37,736.06	2,415.76	6,547.71	31,188.35	0.00	31,188.35	82.65
001-0400-5040	Health Insurance Expense	63,463.20	3,430.27	8,039.55	55,423.65	0.00	55,423.65	87.33
001-0400-5050	Physical & Drug Screen Exp	900.00	0.00	0.00	900.00	0.00	900.00	100.00
001-0400-5055	Uniform Expense	4,100.00	0.00	0.00	4,100.00	3,543.00	557.00	13.59
001-0400-5057	Vehicle Allowance	6,000.00	230.77	923.08	5,076.92	0.00	5,076.92	84.62
001-0400-5060	Travel & Training Expense	1,300.00	0.00	0.00	1,300.00	300.00	1,000.00	76.92
	E01 Sub Totals:	623,358.88	44,460.35	106,119.50	517,239.38	3,843.00	513,396.38	82.36
E10	Building & Grounds Exp							
001-0400-5110	Utilities - Electric	2,300.00	182.36	358.00	1,942.00	0.00	1,942.00	84.43
001-0400-5112	Utilities - Water	3,000.00	290.02	580.04	2,419.96	0.00	2,419.96	80.67
001-0400-5120	Insurance - Property	2,000.00	0.00	0.00	2,000.00	0.00	2,000.00	100.00
001-0400-5130	Sanitation	4,500.00	0.00	0.00	4,500.00	0.00	4,500.00	100.00
001-0400-5145	Tools	3,000.00	0.00	112.12	2,887.88	0.00	2,887.88	96.26
	E10 Sub Totals:	14,800.00	472.38	1,050.16	13,749.84	0.00	13,749.84	92.90
E20	Vehicle Expense							
001-0400-5200	Fuel Expense	25,000.00	1,291.69	1,824.86	23,175.14	0.00	23,175.14	92.70

Account Number	Description	Budget Amount	Period Amount	YTD Amount	YTD Var	Encumbered Amount	Available	% Available
001-0400-5225	Insurance Expense - Vehicle	2,700.00	0.00	2,670.25	29.75	0.00	29.75	1.10
E20 Sub Totals:		27,700.00	1,291.69	4,495.11	23,204.89	0.00	23,204.89	83.77
E30	Supply Expense							
001-0400-5322	Supplies - Operating	55,230.00	0.00	0.00	55,230.00	10,990.00	44,240.00	80.10
001-0400-5380	Prisoner Care Expense	1,000.00	0.00	0.00	1,000.00	0.00	1,000.00	100.00
E30 Sub Totals:		56,230.00	0.00	0.00	56,230.00	10,990.00	45,240.00	80.46
E55	Professional Services							
001-0400-5550	Prof Services - Accig & Audit	5,000.00	0.00	0.00	5,000.00	0.00	5,000.00	100.00
001-0400-5586	Prof Services - Other	25,000.00	0.00	0.00	25,000.00	0.00	25,000.00	100.00
E55 Sub Totals:		30,000.00	0.00	0.00	30,000.00	0.00	30,000.00	100.00
E60	Miscellaneous Expense							
001-0400-5608	Computer Software	3,000.00	69.99	69.99	2,930.01	0.00	2,930.01	97.67
E60 Sub Totals:		3,000.00	69.99	69.99	2,930.01	0.00	2,930.01	97.67
E68	Donation Expense							
001-0400-5680	Donation - Boys & Girls Club	0.00	8,750.00	8,750.00	-8,750.00	0.00	-8,750.00	0.00
001-0400-5681	Donation - Sr. Adults	0.00	0.00	0.00	0.00	0.00	0.00	0.00
E68 Sub Totals:		0.00	8,750.00	8,750.00	-8,750.00	0.00	-8,750.00	0.00
Expense Sub Totals:		755,088.88	55,044.41	120,484.76	634,604.12	14,833.00	619,771.12	82.08
Dept 0400 Sub Totals:		-107,911.12	-16,872.25	-23,348.56	-84,562.56	14,833.00		
R36	Park Program Fees							
001-0410-4384	Tennis	500.00	0.00	0.00	500.00	0.00	500.00	100.00
R36 Sub Totals:		500.00	0.00	0.00	500.00	0.00	500.00	100.00
R50	Sale of Services							
001-0410-4500	Mills Pool-Admin/Concessions	40,000.00	150.00	150.00	39,850.00	0.00	39,850.00	99.63
001-0410-4534	Pavillion Fees	4,500.00	65.00	145.00	4,355.00	0.00	4,355.00	96.78
R50 Sub Totals:		44,500.00	215.00	295.00	44,205.00	0.00	44,205.00	99.34
Revenue Sub Totals:		45,000.00	215.00	295.00	44,705.00	0.00	44,705.00	99.34
E01	Personnel Expense							
001-0410-5020	FICA Expense	1,912.60	0.00	0.00	1,912.60	0.00	1,912.60	100.00
001-0410-5022	Unemployment Expense	750.00	0.00	0.00	750.00	0.00	750.00	100.00
001-0410-5025	Worker's Comp Expense	500.00	0.00	483.46	16.54	0.00	16.54	3.31

Account Number	Description	Budget Amount	Period Amount	YTD Amount	YTD Var	Encumbered Amount	Available	% Available
001-0410-5050	Physical & Drug Screen Exp	2,550.00	0.00	0.00	2,550.00	0.00	2,550.00	100.00
E01 Sub Totals:		5,712.60	0.00	483.46	5,229.14	0.00	5,229.14	91.54
E10	Building & Grounds Exp							
001-0410-5001	Park Mills - Part Time Labor	25,000.00	0.00	0.00	25,000.00	0.00	25,000.00	100.00
001-0410-5102	Repairs & Maint - Building	1,000.00	0.00	0.00	1,000.00	0.00	1,000.00	100.00
001-0410-5104	Repairs & Maint - Grounds	9,198.00	0.00	0.00	9,198.00	0.00	9,198.00	100.00
001-0410-5105	Repairs & Maint - Pool	0.00	0.00	0.00	0.00	0.00	0.00	0.00
001-0410-5110	Utilities - Electric	4,500.00	555.24	570.22	3,929.78	0.00	3,929.78	87.33
001-0410-5112	Utilities - Water	1,500.00	53.68	107.36	1,392.64	0.00	1,392.64	92.84
001-0410-5120	Insurance - Property	750.00	0.00	0.00	750.00	0.00	750.00	100.00
001-0410-5130	Sanitation	3,500.00	342.64	774.91	2,725.09	0.00	2,725.09	77.86
E10 Sub Totals:		45,448.00	951.56	1,452.49	43,995.51	0.00	43,995.51	96.80
E30	Supply Expense							
001-0410-5308	Supplies - Concession	2,500.00	0.00	0.00	2,500.00	0.00	2,500.00	100.00
001-0410-5328	Supplies - Pools	3,500.00	0.00	0.00	3,500.00	0.00	3,500.00	100.00
E30 Sub Totals:		6,000.00	0.00	0.00	6,000.00	0.00	6,000.00	100.00
Expense Sub Totals:		57,160.60	951.56	1,935.95	55,224.65	0.00	55,224.65	96.61
Dept 0410 Sub Totals:		12,160.60	736.56	1,640.95	10,519.65	0.00		
Dept 001-0420	Building & Grounds Exp							
E10	Building & Grounds Exp							
001-0420-5104		0.00	0.00	0.00	0.00	0.00	0.00	0.00
E10 Sub Totals:		0.00	0.00	0.00	0.00	0.00	0.00	0.00
Expense Sub Totals:		0.00	0.00	0.00	0.00	0.00	0.00	0.00
Dept 0420 Sub Totals:		0.00	0.00	0.00	0.00	0.00		
Dept 001-0430	Membership Fees							
R30	Membership Family							
001-0430-4300		224,000.00	16,542.92	31,586.84	192,413.16	0.00	192,413.16	85.90
001-0430-4301	Membership Senior	80,000.00	8,080.00	16,320.00	63,680.00	0.00	63,680.00	79.60
001-0430-4302	Membership Adults	60,000.00	4,610.00	9,055.00	50,945.00	0.00	50,945.00	84.91
001-0430-4303	Membership Youth	20,000.00	1,910.00	3,850.00	16,150.00	0.00	16,150.00	80.75
001-0430-4304	Membership Silver Sneakers	40,000.00	3,676.50	7,479.00	32,521.00	0.00	32,521.00	81.30
001-0430-4310	Membership 3 Mo Adult	550.00	0.00	0.00	550.00	0.00	550.00	100.00
001-0430-4311	Membership 3 Mo Youth	7,000.00	600.00	1,155.00	5,845.00	0.00	5,845.00	83.50
001-0430-4312	Membership 3 Mo Senior	8,500.00	675.00	2,250.00	6,250.00	0.00	6,250.00	73.53
001-0430-4313	Membership 3 Mo Family	14,000.00	1,640.00	2,935.00	11,065.00	0.00	11,065.00	79.04

Account Number	Description	Budget Amount	Period Amount	YTD Amount	YTD Var	Encumbered Amount	Available	% Available
001-0430-4314	Membership 3 Mo College	2,000.00	0.00	0.00	2,000.00	0.00	2,000.00	100.00
001-0430-4318	Membership 6 Mo College	3,000.00	0.00	0.00	3,000.00	0.00	3,000.00	100.00
001-0430-4319	Membership 6 Mo Military	2,400.00	0.00	0.00	2,400.00	0.00	2,400.00	100.00
001-0430-4320	Membership Annual Adult	5,000.00	544.54	1,959.08	3,040.92	0.00	3,040.92	60.82
001-0430-4321	Membership Annual Youth	6,500.00	370.00	980.00	5,520.00	0.00	5,520.00	84.92
001-0430-4322	Membership Annual Senior	45,000.00	2,760.00	10,120.00	34,880.00	0.00	34,880.00	77.51
001-0430-4323	Membership Annual Family	25,000.00	534.00	2,832.00	22,168.00	0.00	22,168.00	88.67
001-0430-4384	Spec Prgms-Tennis Youth	3,000.00	350.00	350.00	2,650.00	0.00	2,650.00	88.33
	R30 Sub Totals:	545,950.00	42,292.96	90,871.92	455,078.08	0.00	455,078.08	83.36
R33	Rental Fees							
001-0430-4332	Equipment Rental	3,000.00	90.00	220.00	2,780.00	0.00	2,780.00	92.67
001-0430-4334	After Hours Charge Bishop	1,000.00	135.00	135.00	865.00	0.00	865.00	86.50
001-0430-4336	Room Rental Large Room (both)	8,000.00	500.00	2,550.00	5,450.00	0.00	5,450.00	68.13
001-0430-4337	Room Rental Large Room	15,000.00	1,570.00	2,440.00	12,560.00	0.00	12,560.00	83.73
001-0430-4338	Room Rental Small Rooms (both)	3,000.00	125.00	685.00	2,315.00	0.00	2,315.00	77.17
001-0430-4339	Room Rental Small Room	5,200.00	350.00	1,150.00	4,050.00	0.00	4,050.00	77.88
001-0430-4340	Room Rental Party Room	30,000.00	2,760.00	5,400.00	24,600.00	0.00	24,600.00	82.00
001-0430-4341	Room Rental Court Gym	7,000.00	525.00	1,475.00	5,525.00	0.00	5,525.00	78.93
001-0430-4342	Room Rental Full Gym	2,000.00	2,050.00	2,050.00	-50.00	0.00	-50.00	0.00
001-0430-4343	Room Rental Full Facility	2,000.00	0.00	0.00	2,000.00	0.00	2,000.00	100.00
001-0430-4344	Room Rental Fitness Room	1,000.00	0.00	370.00	630.00	0.00	630.00	63.00
001-0430-4345	Rental - Splash Pad	6,500.00	0.00	0.00	6,500.00	0.00	6,500.00	100.00
001-0430-4347	Competitive Pool Fees	10,000.00	369.00	1,275.00	8,725.00	0.00	8,725.00	87.25
001-0430-4348	Therapy Pool Fees	1,000.00	0.00	0.00	1,000.00	0.00	1,000.00	100.00
001-0430-4350	Use Agreement Fees	3,500.00	0.00	0.00	3,500.00	0.00	3,500.00	100.00
001-0430-4352	Rental - Outdoor Field Fees	0.00	0.00	0.00	0.00	0.00	0.00	0.00
001-0430-4354	Tournaments	40,000.00	1,410.00	1,410.00	38,590.00	0.00	38,590.00	96.48
	R33 Sub Totals:	138,200.00	9,884.00	19,160.00	119,040.00	0.00	119,040.00	86.14
R36	Park Program Fees							
001-0430-4364	Basketball	30,000.00	803.00	12,858.00	17,142.00	0.00	17,142.00	57.14
001-0430-4366	BASS Swim Program	32,500.00	3,745.75	7,510.75	24,989.25	0.00	24,989.25	76.89
001-0430-4370	Flag Football	5,000.00	0.00	0.00	5,000.00	0.00	5,000.00	100.00
001-0430-4374	Life Coach Class	0.00	858.13	1,743.31	-1,743.31	0.00	-1,743.31	0.00
001-0430-4376	Programs - Misc Activity	1,000.00	0.00	0.00	1,000.00	0.00	1,000.00	100.00
001-0430-4382	Pool Swim Lessons	55,000.00	5,310.00	8,870.00	46,130.00	0.00	46,130.00	83.87
001-0430-4386	Track	1,500.00	0.00	0.00	1,500.00	0.00	1,500.00	100.00
001-0430-4390	Volleyball Adult/Youth	10,000.00	285.00	825.00	9,175.00	0.00	9,175.00	91.75
	R36 Sub Totals:	135,000.00	11,001.88	31,807.06	103,192.94	0.00	103,192.94	76.44
R50	Sale of Services							
001-0430-4500	Concessions - Bishop	30,000.00	8,436.13	19,055.74	10,944.26	0.00	10,944.26	36.48
001-0430-4514	Daily Admissions Adults	28,000.00	1,262.00	3,744.00	24,256.00	0.00	24,256.00	86.63

Account Number	Description	Budget Amount	Period Amount	YTD Amount	YTD Var	Encumbered Amount	Available	% Available
001-0430-4516	Daily Admissions Senior	1,500.00	77.00	189.00	1,311.00	0.00	1,311.00	87.40
001-0430-4518	Daily Admissions Youth	25,000.00	1,004.00	2,196.00	22,804.00	0.00	22,804.00	91.22
001-0430-4520	Multiple Adults	7,500.00	405.00	1,395.00	6,105.00	0.00	6,105.00	81.40
001-0430-4522	Multiple Senior	1,300.00	90.00	270.00	1,030.00	0.00	1,030.00	79.23
001-0430-4524	Multiple Youth	2,500.00	180.00	210.00	2,290.00	0.00	2,290.00	91.60
001-0430-4530	Merchandise Sales	3,500.00	53.00	130.00	3,370.00	0.00	3,370.00	96.29
001-0430-4532	Spectator Admissions	6,000.00	0.00	0.00	6,000.00	0.00	6,000.00	100.00
001-0430-4534	Red Cross Programs	5,000.00	175.00	1,005.00	3,995.00	0.00	3,995.00	79.90
R50 Sub Totals:		110,300.00	11,682.13	28,194.74	82,105.26	0.00	82,105.26	74.44
R60	Miscellaneous Revenue							
001-0430-4600	Miscellaneous Revenue	1,000.00	0.00	0.00	1,000.00	0.00	1,000.00	100.00
R60 Sub Totals:		1,000.00	0.00	0.00	1,000.00	0.00	1,000.00	100.00
R70	Grant Revenue							
001-0430-4702	Grant - Veterans	50,000.00	0.00	0.00	50,000.00	0.00	50,000.00	100.00
R70 Sub Totals:		50,000.00	0.00	0.00	50,000.00	0.00	50,000.00	100.00
R74	Sponsorships							
001-0430-4740	Sponsorship/Rebates	10,000.00	0.00	300.00	9,700.00	0.00	9,700.00	97.00
001-0430-4742	Scoreboard Signage BP	110,000.00	1,750.34	5,500.68	104,499.32	0.00	104,499.32	95.00
R74 Sub Totals:		120,000.00	1,750.34	5,800.68	114,199.32	0.00	114,199.32	95.17
Revenue Sub Totals:		1,100,450.00	76,611.31	175,834.40	924,615.60	0.00	924,615.60	84.02
E01	Personnel Expense							
001-0430-5000	Salary Expense	304,348.19	19,702.53	49,049.34	255,298.85	0.00	255,298.85	83.88
001-0430-5001	Park Bishop - Part Time Labor	45,000.00	6,618.09	17,426.54	27,573.46	0.00	27,573.46	61.27
001-0430-5010	Overtime Expense	5,000.00	521.43	1,543.73	3,456.27	0.00	3,456.27	69.13
001-0430-5020	FICA Expense	34,022.68	2,021.62	5,137.48	28,885.20	0.00	28,885.20	84.90
001-0430-5022	Unemployment Expense	10,464.14	0.00	689.66	9,774.48	0.00	9,774.48	93.41
001-0430-5025	Worker's Comp Expense	9,000.00	0.00	8,702.36	297.64	0.00	297.64	3.31
001-0430-5030	APERS Expense	39,335.00	2,985.07	7,467.56	31,867.44	0.00	31,867.44	81.02
001-0430-5040	Health Insurance Expense	58,987.20	4,156.28	8,312.56	50,674.64	0.00	50,674.64	85.91
001-0430-5050	Physical & Drug Screen Exp	1,500.00	300.00	300.00	1,200.00	0.00	1,200.00	80.00
001-0430-5055	Uniform Expense	3,000.00	0.00	0.00	3,000.00	0.00	3,000.00	100.00
E01 Sub Totals:		510,657.21	36,305.02	98,629.23	412,027.98	0.00	412,027.98	80.69
E10	Building & Grounds Exp							
001-0430-5102	Repairs & Maint - Building	19,500.00	4,423.29	4,494.14	15,005.86	21.33	14,984.53	76.84
001-0430-5104	Repairs & Maint - Grounds	37,400.00	5,632.03	6,056.26	31,343.74	27,411.98	3,931.76	10.51
001-0430-5105	Repairs & Maint - Pool	45,000.00	4,020.78	6,077.46	38,922.54	4,990.41	33,932.13	75.40
001-0430-5106	Repairs & Maint - Splash Pad	2,492.00	0.00	0.00	2,492.00	0.00	2,492.00	100.00

Account Number	Description	Budget Amount	Period Amount	YTD Amount	YTD Var	Encumbered Amount	Available	% Available
001-0430-5110	Utilities - Electric	185,000.00	15,480.60	29,253.92	155,746.08	0.00	155,746.08	84.19
001-0430-5111	Utilities - Gas	48,000.00	5,553.96	5,553.96	42,446.04	0.00	42,446.04	88.43
001-0430-5112	Utilities - Water	18,000.00	883.85	1,796.01	16,203.99	0.00	16,203.99	90.02
001-0430-5115	Communication Exp - Telephone	16,000.00	1,335.48	2,670.83	13,329.17	0.00	13,329.17	83.31
001-0430-5116	Communication Exp - Cellular	10,200.00	454.49	908.35	9,291.65	0.00	9,291.65	91.09
001-0430-5120	Insurance - Property	35,000.00	0.00	0.00	35,000.00	0.00	35,000.00	100.00
001-0430-5130	Sanitation	18,000.00	1,774.41	2,836.13	15,163.87	0.00	15,163.87	84.24
001-0430-5140	Supplies - B&G	2,000.00	28.12	28.12	1,971.88	0.00	1,971.88	98.59
	E10 Sub Totals:	436,592.00	39,587.01	59,675.18	376,916.82	32,423.72	344,493.10	78.91
E20	Vehicle Expense							
001-0430-5212	Service & Repair - Equipment	5,000.00	0.00	0.00	5,000.00	94.85	4,905.15	98.10
	E20 Sub Totals:	5,000.00	0.00	0.00	5,000.00	94.85	4,905.15	98.10
E30	Supply Expense							
001-0430-5300	Supplies - Office	1,000.00	0.00	571.29	428.71	415.00	13.71	1.37
001-0430-5308	Supplies - Concession	32,500.00	3,094.99	8,913.99	23,586.01	3,711.90	19,874.11	61.15
001-0430-5330	Supplies - Park Programs	6,000.00	302.69	690.32	5,309.68	1,561.05	3,748.63	62.48
001-0430-5332	Supplies - Resale Merchandise	2,500.00	1,506.54	1,506.54	993.46	0.00	993.46	39.74
	E30 Sub Totals:	42,000.00	4,904.22	11,682.14	30,317.86	5,687.95	24,629.91	58.64
E40	Operations Expense							
001-0430-5141	Pest/Chem/Seed/Fert-Bishop	2,000.00	328.50	617.10	1,382.90	0.00	1,382.90	69.15
001-0430-5142	Janitorial Supplies	20,000.00	2,898.62	7,337.23	12,662.77	0.00	12,662.77	63.31
001-0430-5214	Equipment-Bishop	30,000.00	0.00	0.00	30,000.00	0.00	30,000.00	100.00
001-0430-5460	BASS Program Expense	10,000.00	2,149.00	3,018.95	6,981.05	130.00	6,851.05	68.51
001-0430-5461	Aquatic Program Expense	2,500.00	570.98	570.98	1,929.02	0.00	1,929.02	77.16
001-0430-5475	Credit Card Fees	35,000.00	1,555.12	4,205.57	30,794.43	0.00	30,794.43	87.98
001-0430-5480	Dues & Subscriptions	500.00	0.00	0.00	500.00	0.00	500.00	100.00
	E40 Sub Totals:	100,000.00	7,502.22	15,749.83	84,250.17	130.00	84,120.17	84.12
E55	Professional Services							
001-0430-5553	Prof Services - Advertising	3,000.00	545.00	647.95	2,352.05	487.20	1,864.85	62.16
001-0430-5585	Prof Service - Basketball	0.00	0.00	0.00	0.00	0.00	0.00	0.00
001-0430-5586	Prof Services - Other	90,000.00	17,924.13	30,817.48	59,182.52	476.50	58,706.02	65.23
001-0430-5587	Prof Services - Aerobic Instr	0.00	0.00	0.00	0.00	0.00	0.00	0.00
001-0430-5589	Prof Services - Printing	3,000.00	288.22	288.22	2,711.78	0.00	2,711.78	90.39
	E55 Sub Totals:	96,000.00	18,757.35	31,753.65	64,246.35	963.70	63,282.65	65.92
E60	Miscellaneous Expense							
001-0430-5485	Inspections & Monitoring	6,500.00	428.11	761.84	5,738.16	0.00	5,738.16	88.28
001-0430-5608	Computer Software	11,200.00	0.00	0.00	11,200.00	0.00	11,200.00	100.00

Account Number	Description	Budget Amount	Period Amount	YTD Amount	YTD Var	Encumbered Amount	Available	% Available
E70	E60 Sub Totals:	17,700.00	428.11	761.84	16,938.16	0.00	16,938.16	95.70
001-0430-5700	Grant Expense							
	Grant Expense	115,000.00	0.00	0.00	115,000.00	16,877.50	98,122.50	85.32
E80	E70 Sub Totals:	115,000.00	0.00	0.00	115,000.00	16,877.50	98,122.50	85.32
	Fixed Assets							
001-0430-5810	Fixed Assets - Equip/Imp.	85,000.00	0.00	0.00	85,000.00	0.00	85,000.00	100.00
001-0430-5813	Fixed Assets - Scoreboard	85,000.00	0.00	0.00	85,000.00	0.00	85,000.00	100.00
E85	E80 Sub Totals:	170,000.00	0.00	0.00	170,000.00	0.00	170,000.00	100.00
	Interest Expense							
001-0430-5850	Interest Expense	4,000.00	0.00	0.00	4,000.00	0.00	4,000.00	100.00
E85	E85 Sub Totals:	4,000.00	0.00	0.00	4,000.00	0.00	4,000.00	100.00
	Expense Sub Totals:	1,496,949.21	107,483.93	218,251.87	1,278,697.34	56,177.72	1,222,519.62	81.67
Dept 001-0500	Dept 0430 Sub Totals:	396,499.21	30,872.62	42,417.47	354,081.74	56,177.72		
R15	Fire Department							
001-0500-4156	Taxes - Property	0.00	26.61	26.61	-26.61	0.00	-26.61	0.00
	Fire Rescue Funds							
R15	R15 Sub Totals:	0.00	26.61	26.61	-26.61	0.00	-26.61	0.00
R62	Intergovernmental Tsfrs							
001-0500-4627	Xfer Designated Tax	960,000.00	80,000.00	160,000.00	800,000.00	0.00	800,000.00	83.33
001-0500-4629	Xfer Fire Special Tax	1,440,000.00	105,416.66	210,833.32	1,229,166.68	0.00	1,229,166.68	85.36
R62	R62 Sub Totals:	2,400,000.00	185,416.66	370,833.32	2,029,166.68	0.00	2,029,166.68	84.55
E01	Revenue Sub Totals:	2,400,000.00	185,443.27	370,859.93	2,029,140.07	0.00	2,029,140.07	84.55
001-0500-5000	Personnel Expense							
001-0500-5010	Salary Expense	2,025,576.26	149,771.06	389,703.43	1,635,872.83	0.00	1,635,872.83	80.76
001-0500-5020	Overtime Expense	184,000.00	7,573.64	20,495.88	163,504.12	0.00	163,504.12	88.86
001-0500-5022	FICA Expense	34,140.60	2,365.22	6,176.92	27,963.68	0.00	27,963.68	81.91
001-0500-5025	Unemployment Expense	17,640.00	0.00	425.86	17,214.14	0.00	17,214.14	97.59
001-0500-5030	Worker's Comp Expense	79,000.00	0.00	78,378.08	621.92	0.00	621.92	0.79
001-0500-5035	APERS Expense	5,163.36	384.25	962.22	4,201.14	0.00	4,201.14	81.36
001-0500-5036	LOPFI Expense	442,324.62	31,520.85	51,884.75	390,439.87	0.00	390,439.87	88.27
001-0500-5040	LOPFI Perm Advance	-150,000.00	0.00	0.00	-150,000.00	0.00	-150,000.00	0.00
001-0500-5050	Health Insurance Expense	377,102.40	31,289.60	62,781.48	314,320.92	0.00	314,320.92	83.35
001-0500-5055	Physical & Drug Screen Exp	13,750.00	35.00	674.00	13,076.00	236.58	12,839.42	93.38
	Uniform Expense	16,000.00	709.48	751.09	15,248.91	244.16	15,004.75	93.78

Account Number	Description	Budget Amount	Period Amount	YTD Amount	YTD Var	Encumbered Amount	Available	% Available
001-0500-5060	Travel & Training Expense	8,500.00	0.00	-1,174.66	9,674.66	0.00	9,674.66	113.82
E01 Sub Totals:		3,053,197.24	223,649.10	611,059.05	2,442,138.19	480.74	2,441,657.45	79.97
E10	Building & Grounds Exp							
001-0500-5102	Repairs & Maint - Building	17,400.00	6,396.36	6,655.09	10,744.91	470.61	10,274.30	59.05
001-0500-5110	Utilities - Electric	37,000.00	2,777.21	5,480.69	31,519.31	0.00	31,519.31	85.19
001-0500-5111	Utilities - Gas	6,000.00	1,030.46	1,447.77	4,552.23	0.00	4,552.23	75.87
001-0500-5112	Utilities - Water	6,500.00	388.33	920.00	5,580.00	0.00	5,580.00	85.85
001-0500-5115	Communication Exp - Telephone	21,000.00	1,448.11	2,286.38	18,713.62	1,008.84	17,704.78	84.31
001-0500-5116	Communication Exp - Cellular	4,000.00	223.84	459.36	3,540.64	0.00	3,540.64	88.52
001-0500-5120	Insurance - Property	10,500.00	0.00	0.00	10,500.00	0.00	10,500.00	100.00
001-0500-5130	Sanitation	1,500.00	0.00	0.00	1,500.00	0.00	1,500.00	100.00
001-0500-5145	Tools	1,200.00	34.65	34.65	1,165.35	248.03	917.32	76.44
E10 Sub Totals:		105,100.00	12,298.96	17,283.94	87,816.06	1,727.48	86,088.58	81.91
E20	Vehicle Expense							
001-0500-5200	Fuel Expense	48,000.00	2,095.51	4,564.04	43,435.96	0.00	43,435.96	90.49
001-0500-5212	Service & Repair - Equipment	3,000.00	0.00	0.00	3,000.00	0.00	3,000.00	100.00
001-0500-5215	R & M Vehicle	2,400.00	0.00	0.00	2,400.00	12.30	2,387.70	99.49
001-0500-5216	Service & Repair - Apparatus	22,000.00	903.44	1,533.63	20,466.37	1,656.39	18,809.98	85.50
001-0500-5225	Insurance Expense - Vehicle	27,000.00	0.00	19,934.50	7,065.50	0.00	7,065.50	26.17
001-0500-5230	Radios	6,000.00	194.91	389.82	5,610.18	0.00	5,610.18	93.50
E20 Sub Totals:		108,400.00	3,193.86	26,421.99	81,978.01	1,668.69	80,309.32	74.09
E30	Supply Expense							
001-0500-5141	Pest/Chem/Seed/Fert-Fire	1,200.00	0.00	0.00	1,200.00	0.00	1,200.00	100.00
001-0500-5142	Janitorial Supplies-Fire	11,000.00	510.65	1,271.77	9,728.23	16.49	9,711.74	88.29
001-0500-5300	Supplies - Office	3,000.00	0.00	17.49	2,982.51	0.00	2,982.51	99.42
001-0500-5302	Supplies - Kitchen	1,200.00	3.10	3.10	1,196.90	0.00	1,196.90	99.74
001-0500-5304	Supplies - Extinguisher	500.00	0.00	0.00	500.00	0.00	500.00	100.00
001-0500-5306	Supplies - Food Allowance	43,800.00	3,127.81	3,127.81	40,672.19	3,102.66	37,569.53	85.78
001-0500-5318	Supplies - Foam	1,500.00	0.00	0.00	1,500.00	0.00	1,500.00	100.00
001-0500-5320	Supplies - Hazardous Mat'l	2,000.00	92.10	92.10	1,907.90	175.75	1,732.15	86.61
001-0500-5350	Postage Expense	500.00	0.00	0.00	500.00	0.00	500.00	100.00
E30 Sub Totals:		64,700.00	3,733.66	4,512.27	60,187.73	3,294.90	56,892.83	87.93
E40	Operations Expense							
001-0500-5061	Training Aids-Fire	9,550.00	0.00	0.00	9,550.00	33.04	9,516.96	99.65
001-0500-5217	Equipment Repair - Fire	3,000.00	0.00	0.00	3,000.00	0.00	3,000.00	100.00
001-0500-5218	Pager Purchase/Repair - Fire	3,000.00	0.00	0.00	3,000.00	0.00	3,000.00	100.00
001-0500-5323	Material and Maint. Fire	1,600.00	0.00	0.00	1,600.00	332.00	1,268.00	79.25
001-0500-5480	Dues & Subscriptions	1,500.00	0.00	0.00	1,500.00	0.00	1,500.00	100.00
001-0500-5530	Safety Program	10,000.00	0.00	0.00	10,000.00	0.00	10,000.00	100.00

Account Number	Description	Budget Amount	Period Amount	YTD Amount	YTD Var	Encumbered Amount	Available	% Available
E40 Sub Totals:		28,650.00	0.00	0.00	28,650.00	365.04	28,284.96	98.73
E55	Professional Services							
001-0500-5553	Prof Services - Advertising	1,000.00	0.00	0.00	1,000.00	0.00	1,000.00	100.00
001-0500-5586	Prof Services - Other	1,500.00	0.00	0.00	1,500.00	0.00	1,500.00	100.00
001-0500-5589	Prof Services - Printing	1,000.00	60.00	60.00	940.00	0.00	940.00	94.00
E55 Sub Totals:		3,500.00	60.00	60.00	3,440.00	0.00	3,440.00	98.29
E60	Miscellaneous Expense							
001-0500-5606	Computer Maint & Support	3,500.00	0.00	0.00	3,500.00	2,700.00	800.00	22.86
E60 Sub Totals:		3,500.00	0.00	0.00	3,500.00	2,700.00	800.00	22.86
E70	Grant Expense							
001-0500-5700	Grant Expense	212.23	0.00	0.00	212.23	0.00	212.23	100.00
E70 Sub Totals:		212.23	0.00	0.00	212.23	0.00	212.23	100.00
E80	Fixed Assets							
001-0500-5808	Fixed Assets - Vehicles	0.00	14,657.84	14,657.84	-14,657.84	0.00	-14,657.84	0.00
001-0500-5830	Springhill Fire Department	50,000.00	0.00	0.00	50,000.00	821.25	49,178.75	98.36
E80 Sub Totals:		50,000.00	14,657.84	14,657.84	35,342.16	821.25	34,520.91	69.04
Expense Sub Totals:		3,417,259.47	257,593.42	673,995.09	2,743,264.38	11,058.10	2,732,206.28	79.95
Dept 0500 Sub Totals:		1,017,259.47	72,150.15	303,135.16	714,124.31	11,058.10		
R15	Taxes - Property							
001-0510-4152	Springhill VPD Assessment	50,000.00	0.00	0.00	50,000.00	0.00	50,000.00	100.00
R15 Sub Totals:		50,000.00	0.00	0.00	50,000.00	0.00	50,000.00	100.00
Revenue Sub Totals:		50,000.00	0.00	0.00	50,000.00	0.00	50,000.00	100.00
E40	Operations Expense							
001-0510-5800	Springhill VPD - Expense	0.00	0.00	0.00	0.00	0.00	0.00	0.00
E40 Sub Totals:		0.00	0.00	0.00	0.00	0.00	0.00	0.00
Expense Sub Totals:		0.00	0.00	0.00	0.00	0.00	0.00	0.00
Dept 0510 Sub Totals:		-50,000.00	0.00	0.00	-50,000.00	0.00		
R40	Police							
001-0600	Fines & Forfeitures							

Account Number	Description	Budget Amount	Period Amount	YTD Amount	YTD Var	Encumbered Amount	Available	% Available
001-0600-4422	Intoximeter Revenue	700.00	0.00	0.00	700.00	0.00	700.00	100.00
R40 Sub Totals:		700.00	0.00	0.00	700.00	0.00	700.00	100.00
R62	Intergovernmental Tsfrs							
001-0600-4627	Xfer Designated Tax	960,000.00	80,000.00	160,000.00	800,000.00	0.00	800,000.00	83.33
R62 Sub Totals:		960,000.00	80,000.00	160,000.00	800,000.00	0.00	800,000.00	83.33
R70	Grant Revenue							
001-0600-4700	Grant - Police DUJ/Step	25,000.00	0.00	0.00	25,000.00	0.00	25,000.00	100.00
001-0600-4702	Grant - Body Armor	9,000.00	0.00	0.00	9,000.00	0.00	9,000.00	100.00
001-0600-4704	Grant - JAG Equip	6,700.00	0.00	0.00	6,700.00	0.00	6,700.00	100.00
R70 Sub Totals:		40,700.00	0.00	0.00	40,700.00	0.00	40,700.00	100.00
Revenue Sub Totals:		1,001,400.00	80,000.00	160,000.00	841,400.00	0.00	841,400.00	84.02
E01	Personnel Expense							
001-0600-5000	Salary Expense	1,551,133.34	122,201.47	321,840.39	1,229,292.95	0.00	1,229,292.95	79.25
001-0600-5010	Overtime Expense	65,000.00	3,209.62	5,941.09	59,058.91	0.00	59,058.91	90.86
001-0600-5020	FICA Expense	123,414.02	9,475.44	24,808.45	98,605.57	0.00	98,605.57	79.90
001-0600-5022	Unemployment Expense	12,960.00	0.00	0.00	12,960.00	0.00	12,960.00	100.00
001-0600-5025	Worker's Comp Expense	26,000.00	0.00	24,389.62	1,610.38	0.00	1,610.38	6.19
001-0600-5030	APERS Expense	24,535.61	1,908.02	5,037.53	19,498.08	0.00	19,498.08	79.47
001-0600-5035	LOPFI Expense	320,879.11	29,951.44	38,400.74	282,478.37	0.00	282,478.37	88.03
001-0600-5036	LOPFI Prem Advance	-135,000.00	0.00	0.00	-135,000.00	0.00	-135,000.00	0.00
001-0600-5040	Health Insurance Expense	281,667.84	24,235.89	47,394.18	234,273.66	0.00	234,273.66	83.17
001-0600-5050	Physical & Drug Screen Exp	3,000.00	0.00	175.00	2,825.00	0.00	2,825.00	94.17
001-0600-5055	Uniform Expense	14,000.00	131.87	210.90	13,789.10	0.00	13,789.10	98.49
001-0600-5056	Uniform Expense - Cleaning	15,120.00	1,020.00	2,040.00	13,080.00	0.00	13,080.00	86.51
001-0600-5057	Uniform Expense - New Officer	15,000.00	0.00	0.00	15,000.00	0.00	15,000.00	100.00
001-0600-5060	Travel & Training Expense	23,000.00	1,819.00	1,819.00	21,181.00	1,867.03	19,313.97	83.97
001-0600-5065	First Aid Expense	500.00	0.00	0.00	500.00	0.00	500.00	100.00
001-0600-5705	Grant Expense - DUJ/Step	25,000.00	320.77	503.12	24,496.88	0.00	24,496.88	97.99
E01 Sub Totals:		2,366,209.92	194,273.52	472,560.02	1,893,649.90	1,867.03	1,891,782.87	79.95
E10	Building & Grounds Exp							
001-0600-5102	Repairs & Maint - Building	0.00	299.18	299.18	-299.18	0.00	-299.18	0.00
001-0600-5110	Utilities - Electric	14,000.00	955.17	1,914.83	12,085.17	0.00	12,085.17	86.32
001-0600-5111	Utilities - Gas	1,250.00	179.49	244.04	1,005.96	0.00	1,005.96	80.48
001-0600-5112	Utilities - Water	2,700.00	71.68	184.82	2,515.18	40.72	2,474.46	91.65
001-0600-5115	Communication Exp - Telephone	45,000.00	3,906.32	4,369.92	40,630.08	2,297.95	38,332.13	85.18
001-0600-5120	Insurance - Property	4,500.00	0.00	0.00	4,500.00	0.00	4,500.00	100.00
001-0600-5130	Sanitation	1,900.00	160.81	321.62	1,578.38	0.00	1,578.38	83.07

Account Number	Description	Budget Amount	Period Amount	YTD Amount	YTD Var	Encumbered Amount	Available	% Available
E10	E10 Sub Totals:	69,350.00	5,572.65	7,334.41	62,015.59	2,338.67	59,676.92	86.05
	Vehicle Expense							
	Fuel Expense	175,000.00	10,005.61	15,370.02	159,629.98	0.00	159,629.98	91.22
	Service & Repair - Vehicle	20,000.00	8,136.93	8,836.59	11,163.41	1,195.89	9,967.52	49.84
	Vehicle Expense - Car Wash	200.00	0.00	0.00	200.00	0.00	200.00	100.00
	Equipment - CID - Police	2,400.00	197.75	310.25	2,089.75	0.00	2,089.75	87.07
	Tire Expense	15,000.00	0.00	0.00	15,000.00	0.00	15,000.00	100.00
	Insurance Expense - Vehicle	40,000.00	0.00	16,726.29	23,273.71	0.00	23,273.71	58.18
	Narcotics Rental	6,100.00	0.00	0.00	6,100.00	0.00	6,100.00	100.00
E20	E20 Sub Totals:	258,700.00	18,340.29	41,243.15	217,456.85	1,195.89	216,260.96	83.60
E30	Supply Expense							
	Supplies - Office	5,000.00	505.86	569.62	4,430.38	810.78	3,619.60	72.39
	Supplies - Weapons	3,000.00	0.00	0.00	3,000.00	0.00	3,000.00	100.00
	Supplies - Ammunition	18,000.00	0.00	0.00	18,000.00	0.00	18,000.00	100.00
	Supplies - Raid Vests	13,000.00	0.00	0.00	13,000.00	11,908.13	1,091.87	8.40
	Postage Expense	750.00	8.54	47.00	703.00	75.13	627.87	83.72
	Prisoner Care Expense	1,000.00	0.00	0.00	1,000.00	0.00	1,000.00	100.00
E30	E30 Sub Totals:	40,750.00	514.40	616.62	40,133.38	12,794.04	27,339.34	67.09
E40	Operations Expense							
	Training Aids-Police	3,000.00	35.43	64.09	2,935.91	0.00	2,935.91	97.86
	Communication Exp - Cellular	28,000.00	1,979.06	4,146.19	23,853.81	18.30	23,835.51	85.13
	Pest/Chem/Seed/Fert. Exp	0.00	36.20	36.20	-36.20	0.00	-36.20	0.00
	Equipment Police	3,000.00	0.00	0.00	3,000.00	0.00	3,000.00	100.00
	Service & Repair - Equipment	500.00	0.00	0.00	500.00	0.00	500.00	100.00
	Misc/Equipment - Police	500.00	0.00	0.00	500.00	0.00	500.00	100.00
	Dues & Subscriptions	1,700.00	0.00	201.50	1,498.50	0.00	1,498.50	88.15
	Comm Crime Prevention Outreach	5,000.00	310.95	310.95	4,689.05	0.00	4,689.05	93.78
	Safety Program	2,200.00	0.00	0.00	2,200.00	189.40	2,010.60	91.39
	Radios - Police	15,000.00	0.00	0.00	15,000.00	0.00	15,000.00	100.00
	Computer Software	46,020.00	26,050.00	26,050.00	19,970.00	0.00	19,970.00	43.39
E40	E40 Sub Totals:	104,920.00	28,411.64	30,808.93	74,111.07	207.70	73,903.37	70.44
E55	Professional Services							
	Prof Services - Advertising	1,800.00	0.00	0.00	1,800.00	0.00	1,800.00	100.00
	Prof Services - Bldg & Grounds	5,000.00	302.34	302.34	4,697.66	292.08	4,405.58	88.11
	Prof Services - Other	14,700.00	242.58	613.48	14,086.52	783.54	13,302.98	90.50
	Prof Services - Printing	2,750.00	190.00	190.00	2,560.00	0.00	2,560.00	93.09
	Interpreter-Police	2,500.00	180.00	180.00	2,320.00	180.00	2,140.00	85.60
E60	E55 Sub Totals:	26,750.00	914.92	1,285.82	25,464.18	1,255.62	24,208.56	90.50
	Miscellaneous Expense							

Account Number	Description	Budget Amount	Period Amount	YTD Amount	YTD Var	Encumbered Amount	Available	% Available
001-0600-5606	Computer Maint & Support	17,660.00	2,340.00	2,340.00	15,320.00	11,700.00	3,620.00	20.50
001-0600-5617	Misc/Equipment Police	1,400.00	0.00	0.00	1,400.00	0.00	1,400.00	100.00
E60 Sub Totals:		19,060.00	2,340.00	2,340.00	16,720.00	11,700.00	5,020.00	26.34
E70	Grant Expense							
001-0600-5700	Grant Expense - Jag	6,700.00	0.00	0.00	6,700.00	0.00	6,700.00	100.00
E70 Sub Totals:		6,700.00	0.00	0.00	6,700.00	0.00	6,700.00	100.00
E80	Fixed Assets							
001-0600-5840	Principal Loan - Vehicles	322,215.00	0.00	0.00	322,215.00	0.00	322,215.00	100.00
E80 Sub Totals:		322,215.00	0.00	0.00	322,215.00	0.00	322,215.00	100.00
E85	Interest Expense							
001-0600-5850	Interest Expense	16,714.00	0.00	0.00	16,714.00	0.00	16,714.00	100.00
E85 Sub Totals:		16,714.00	0.00	0.00	16,714.00	0.00	16,714.00	100.00
Expense Sub Totals:		3,231,368.92	250,367.42	556,188.95	2,675,179.97	31,358.95	2,643,821.02	81.82
Dept 0600 Sub Totals:		2,229,968.92	170,367.42	396,188.95	1,833,779.97			
R60	Miscellaneous Revenue							
001-0610-4650	Emerg Telephone Service Rev	70,000.00	0.00	0.00	70,000.00	0.00	70,000.00	100.00
R60 Sub Totals:		70,000.00	0.00	0.00	70,000.00	0.00	70,000.00	100.00
Revenue Sub Totals:		70,000.00	0.00	0.00	70,000.00	0.00	70,000.00	100.00
E01	Personnel Expense							
001-0610-5000	Salary Expense	245,025.19	17,456.40	44,404.02	200,621.17	0.00	200,621.17	81.88
001-0610-5010	Overtime Expense	35,000.00	1,888.20	5,205.04	29,794.96	0.00	29,794.96	85.13
001-0610-5020	FICA Expense	21,258.89	1,443.54	3,715.13	17,543.76	0.00	17,543.76	82.52
001-0610-5022	Unemployment Expense	3,888.57	0.00	0.00	3,888.57	0.00	3,888.57	100.00
001-0610-5025	Worker's Comp Expense	3,600.00	0.00	3,577.14	22.86	0.00	22.86	0.64
001-0610-5030	APERS Expense	36,665.22	2,796.81	7,263.83	29,401.39	0.00	29,401.39	80.19
001-0610-5040	Health Insurance Expense	49,715.52	4,618.25	8,774.53	40,940.99	0.00	40,940.99	82.35
E01 Sub Totals:		395,153.39	28,203.20	72,939.69	322,213.70	0.00	322,213.70	81.54
E55	Professional Services							
001-0610-5400	Comm Service Agreement	12,500.00	0.00	0.00	12,500.00	0.00	12,500.00	100.00
001-0610-5565	Prof Services - Dispatch	9,000.00	0.00	0.00	9,000.00	0.00	9,000.00	100.00
E55 Sub Totals:		21,500.00	0.00	0.00	21,500.00	0.00	21,500.00	100.00

Account Number	Description	Budget Amount	Period Amount	YTD Amount	YTD Var	Encumbered Amount	Available	% Available
Dept 001-0620	Expense Sub Totals:	416,653.39	28,203.20	72,939.69	343,713.70	0.00	343,713.70	82.49
R64	Dept 0610 Sub Totals:	346,653.39	28,203.20	72,939.69	273,713.70	0.00		
001-0620-4640	Reimbursement	228,000.00	0.00	0.00	228,000.00	0.00	228,000.00	100.00
	Bryant School - SRO Reim	228,000.00	0.00	0.00	228,000.00	0.00	228,000.00	100.00
	R64 Sub Totals:	228,000.00	0.00	0.00	228,000.00	0.00	228,000.00	100.00
	Revenue Sub Totals:							
E01	Personnel Expense	297,498.40	20,537.66	53,467.02	244,031.38	0.00	244,031.38	82.03
001-0620-5000	Salary Expense	0.00	61.16	61.16	-61.16	0.00	-61.16	0.00
001-0620-5010	Overtime Expense	22,913.63	1,556.98	4,051.98	18,861.65	0.00	18,861.65	82.32
001-0620-5020	FICA Expense	2,520.00	0.00	0.00	2,520.00	0.00	2,520.00	100.00
001-0620-5022	Unemployment Expense	4,600.00	0.00	4,552.73	47.27	0.00	47.27	1.03
001-0620-5025	Worker's Comp Expense	65,449.65	4,577.93	11,868.59	53,581.06	0.00	53,581.06	81.87
001-0620-5035	LOPFI - SRO	-22,000.00	0.00	0.00	-22,000.00	0.00	-22,000.00	0.00
001-0620-5036	LOPFE Prem Advance - SRO	59,147.04	4,178.67	8,355.98	50,791.06	0.00	50,791.06	85.87
001-0620-5040	Health Insurance Expense	500.00	0.00	0.00	500.00	0.00	500.00	100.00
001-0620-5050	Phys/ Drug Test - SRO	0.00	30.00	60.00	-60.00	0.00	-60.00	0.00
001-0620-5055	Uniform Replacement	5,810.00	180.00	360.00	5,450.00	275.00	5,175.00	89.07
001-0620-5056	Uniform Allowance-SRO Cleaning	7,000.00	0.00	0.00	7,000.00	3,000.00	4,000.00	57.14
001-0620-5060	Travel & Training Expense							
E10	E10 Sub Totals:	443,438.72	31,122.40	82,777.46	360,661.26	3,275.00	357,386.26	80.59
001-0620-5116	Building & Grounds Exp	5,700.00	461.72	946.88	4,753.12	0.00	4,753.12	83.39
	Communication Exp - Cellular	5,700.00	461.72	946.88	4,753.12	0.00	4,753.12	83.39
E60	E60 Sub Totals:	500.00	0.00	0.00	500.00	0.00	500.00	100.00
001-0620-5608	Miscellaneous Expense	500.00	0.00	0.00	500.00	0.00	500.00	100.00
	Computer Software	500.00	0.00	0.00	500.00	0.00	500.00	100.00
	E60 Sub Totals:	449,638.72	31,584.12	83,724.34	365,914.38	3,275.00	362,639.38	80.65
	Expense Sub Totals:	221,638.72	31,584.12	83,724.34	137,914.38	3,275.00		
Dept 001-0630	Dept 0620 Sub Totals:							
E30	Supply Expense	1,000.00	223.41	223.41	776.59	118.78	657.81	65.78
001-0630-5306	Supplies - Food Allowance	1,000.00	223.41	223.41	776.59	118.78	657.81	65.78
	E30 Sub Totals:	1,000.00	223.41	223.41	776.59	118.78	657.81	65.78

Account Number	Description	Budget Amount	Period Amount	YTD Amount	YTD Var	Encumbered Amount	Available	% Available
E40	Operations Expense							
001-0630-5500	K9 Training	3,500.00	0.00	0.00	3,500.00	0.00	3,500.00	100.00
	E40 Sub Totals:	3,500.00	0.00	0.00	3,500.00	0.00	3,500.00	100.00
E55	Professional Services							
001-0630-5592	Prof Services - Veterinarian	2,800.00	0.00	0.00	2,800.00	627.07	2,172.93	77.60
	E55 Sub Totals:	2,800.00	0.00	0.00	2,800.00	627.07	2,172.93	77.60
	Expense Sub Totals:	7,300.00	223.41	223.41	7,076.59	745.85	6,330.74	86.72
	Dept 0630 Sub Totals:	7,300.00	223.41	223.41	7,076.59	745.85		
Dept 001-0700	Taxes - Sales							
R10	Alcohol Sales Tax Collected	0.00	0.00	0.00	0.00	0.00	0.00	0.00
	R10 Sub Totals:	0.00	0.00	0.00	0.00	0.00	0.00	0.00
R20	Licenses Permits & Fees							
001-0700-4200	Act 474 Commercial Surcharge	3,000.00	2,264.80	3,644.30	-644.30	0.00	-644.30	0.00
001-0700-4204	Amusement Game Fees	100.00	100.00	100.00	0.00	0.00	0.00	0.00
001-0700-4208	Business License	60,000.00	2,243.75	9,881.25	50,118.75	0.00	50,118.75	83.53
001-0700-4210	Commercial Remodel Permits	2,500.00	-100.00	34.68	2,465.32	0.00	2,465.32	98.61
001-0700-4212	Drainage Fees	2,000.00	550.00	1,180.00	820.00	0.00	820.00	41.00
001-0700-4214	Electrical Permits	20,000.00	1,524.84	12,463.96	7,536.04	0.00	7,536.04	37.68
001-0700-4216	Electrical Reinspection	500.00	0.00	90.00	410.00	0.00	410.00	82.00
001-0700-4218	Fence Permits	700.00	-50.00	-25.00	725.00	0.00	725.00	103.57
001-0700-4218	HVACR Permits	10,000.00	-349.56	4,856.82	5,143.18	0.00	5,143.18	51.43
001-0700-4220	Mobile Home Permits	500.00	50.00	150.00	350.00	0.00	350.00	70.00
001-0700-4226	New Commercial Permits	10,000.00	4,550.36	11,348.08	-1,348.08	0.00	-1,348.08	0.00
001-0700-4228	Permits - Other	4,000.00	1,162.24	1,202.24	2,797.76	0.00	2,797.76	69.94
001-0700-4230	Plumbing/Gas Inspections	10,000.00	926.38	5,294.68	4,705.32	0.00	4,705.32	47.05
001-0700-4232	Re-Inspection Fees	1,000.00	0.00	30.00	970.00	0.00	970.00	97.00
001-0700-4234	Residential Building Permits	10,000.00	316.32	1,436.65	8,563.35	0.00	8,563.35	85.63
001-0700-4236	Residential Remodel Permits	300.00	71.40	71.40	228.60	0.00	228.60	76.20
001-0700-4238	Sanitation License	300.00	0.00	100.00	200.00	0.00	200.00	66.67
001-0700-4240	Sign Permits	5,000.00	670.00	4,970.00	30.00	0.00	30.00	0.60
001-0700-4242	Solicitation Permits	700.00	15.00	15.00	685.00	0.00	685.00	97.86
001-0700-4244	Storage Building Permits	400.00	153.76	301.81	98.19	0.00	98.19	24.55
001-0700-4248	Swimming Pool Permits	300.00	0.00	120.00	180.00	0.00	180.00	60.00
001-0700-4252	Alcohol Permits - Revenue	15,610.00	375.00	375.00	15,235.00	0.00	15,235.00	97.60
	R20 Sub Totals:	156,910.00	14,474.29	57,640.87	99,269.13	0.00	99,269.13	63.27
R64	Reimbursement							
001-0700-4560	Vacant Home Cleanup - Revenue	0.00	235.00	235.00	-235.00	0.00	-235.00	0.00

Account Number	Description	Budget Amount	Period Amount	YTD Amount	YTD Var	Encumbered Amount	Available	% Available
R64 Sub Totals:		0.00	235.00	235.00	-235.00	0.00	-235.00	0.00
Revenue Sub Totals:		156,910.00	14,709.29	57,875.87	99,034.13	0.00	99,034.13	63.12
E01	Personnel Expense							
001-0700-5000	Salary Expense	148,631.60	11,347.56	28,327.60	120,304.00	0.00	120,304.00	80.94
001-0700-5010	Overtime Expense	2,000.00	0.00	72.29	1,927.71	0.00	1,927.71	96.39
001-0700-5012	First Aid Code	100.00	0.00	0.00	100.00	0.00	100.00	100.00
001-0700-5020	FICA Expense	11,523.33	852.01	2,140.60	9,382.73	0.00	9,382.73	81.42
001-0700-5022	Unemployment Expense	1,440.00	0.00	0.00	1,440.00	0.00	1,440.00	100.00
001-0700-5025	Worker's Comp Expense	500.00	0.00	447.34	52.66	0.00	52.66	10.53
001-0700-5030	APERS Expense	22,361.27	1,674.90	4,191.82	18,169.45	0.00	18,169.45	81.25
001-0700-5040	Health Insurance Expense	31,811.52	2,650.96	5,381.92	26,429.60	0.00	26,429.60	83.08
001-0700-5050	Physical & Drug Screen Exp	325.00	0.00	0.00	325.00	0.00	325.00	100.00
001-0700-5055	Uniform Expense	1,500.00	150.93	150.93	1,349.07	0.00	1,349.07	89.94
001-0700-5060	Travel & Training Expense	1,125.00	0.00	0.00	1,125.00	500.00	625.00	55.56
E01 Sub Totals:		221,317.72	16,676.36	40,712.50	180,605.22	500.00	180,105.22	81.38
E10	Building & Grounds Exp							
001-0700-5100	Building & Grounds Reim	1,500.00	63.70	132.01	1,367.99	9.72	1,358.27	90.55
001-0700-5110	Utilities - Electric Expense	1,000.00	12.38	12.38	987.62	0.00	987.62	98.76
001-0700-5111	Utilities - Gas Expense	1,000.00	0.00	0.00	1,000.00	0.00	1,000.00	100.00
001-0700-5115	Communication Exp - Telephone	1,500.00	134.88	134.88	1,365.12	134.08	1,231.04	82.07
001-0700-5120	Insurance - Property	300.00	0.00	0.00	300.00	0.00	300.00	100.00
E10 Sub Totals:		5,300.00	210.96	279.27	5,020.73	143.80	4,876.93	92.02
E20	Vehicle Expense							
001-0700-5200	Fuel Expense	8,000.00	475.70	871.66	7,128.34	0.00	7,128.34	89.10
001-0700-5210	Service & Repair - Vehicle	0.00	9.57	9.57	-9.57	0.00	-9.57	0.00
001-0700-5225	Insurance Expense - Vehicle	325.00	0.00	325.00	0.00	0.00	0.00	0.00
E20 Sub Totals:		8,325.00	485.27	1,206.23	7,118.77	0.00	7,118.77	85.51
E40	Operations Expense							
001-0700-5116	Communication Exp - Cellular	1,800.00	197.88	395.52	1,404.48	0.00	1,404.48	78.03
001-0700-5405	Act 474 Surcharge	8,000.00	2,354.69	2,361.03	5,638.97	4,423.49	1,215.48	15.19
001-0700-5475	Credit Card Fees	1,200.00	351.82	503.86	696.14	0.00	696.14	58.01
001-0700-5480	Dues & Subscriptions	500.00	154.94	207.73	292.27	2.80	289.47	57.89
001-0700-5560	Vacant Home Cleanup	4,000.00	0.00	0.00	4,000.00	0.00	4,000.00	100.00
E40 Sub Totals:		15,500.00	3,059.33	3,468.14	12,031.86	4,426.29	7,605.57	49.07
E55	Professional Services							
001-0700-5568	Prof Services - Elec Insp	10,000.00	667.50	1,367.50	8,632.50	0.00	8,632.50	86.33
001-0700-5589	Prof Services - Printing	500.00	40.00	40.00	460.00	0.00	460.00	92.00

Account Number	Description	Budget Amount	Period Amount	YTD Amount	YTD Var	Encumbered Amount	Available	% Available
	E55 Sub Totals:	10,500.00	707.50	1,407.50	9,092.50	0.00	9,092.50	86.60
	Expense Sub Totals:	260,942.72	21,139.42	47,073.64	213,869.08	5,070.09	208,798.99	80.02
	Dept 0700 Sub Totals:	104,032.72	6,430.13	-10,802.23	114,834.95	5,070.09		
	Fund Revenue Sub Totals:	12,059,930.00	854,066.15	1,834,875.92	0,225,054.08	0.00	10,225,054.08	84.79
	Fund Expense Sub Totals:	12,077,162.31	901,337.81	2,104,988.21	9,972,174.10	206,093.95	9,766,080.15	80.86
	Fund 001 Sub Totals:	17,232.31	47,271.66	270,112.29	-252,879.98	206,093.95		

Account Number	Description	Budget Amount	Period Amount	YTD Amount	YTD Var	Encumbered Amount	Available	% Available
Fund 002	Sales Tax Fund							
Dept 002-0100	Administration							
R10	Taxes - Sales							
002-0100-4105	One Cent Sales Tax	3,835,000.00	387,484.05	688,004.52	3,146,995.48	0.00	3,146,995.48	82.06
	R10 Sub Totals:	3,835,000.00	387,484.05	688,004.52	3,146,995.48	0.00	3,146,995.48	82.06
R85	Interest Revenue							
002-0100-4850	Interest Revenue	0.00	14.72	31.56	-31.56	0.00	-31.56	0.00
	R85 Sub Totals:	0.00	14.72	31.56	-31.56	0.00	-31.56	0.00
	Revenue Sub Totals:	3,835,000.00	387,498.77	688,036.08	3,146,963.92	0.00	3,146,963.92	82.06
E62	Intergovernmental Tsfr							
002-0100-5620	Xfer to General	3,835,000.00	319,583.33	639,166.66	3,195,833.34	0.00	3,195,833.34	83.33
	E62 Sub Totals:	3,835,000.00	319,583.33	639,166.66	3,195,833.34	0.00	3,195,833.34	83.33
	Expense Sub Totals:	3,835,000.00	319,583.33	639,166.66	3,195,833.34	0.00	3,195,833.34	83.33
	Dept 0100 Sub Totals:	0.00	-67,915.44	-48,869.42	48,869.42	0.00		
	Fund Revenue Sub Totals:	3,835,000.00	387,498.77	688,036.08	3,146,963.92	0.00	3,146,963.92	82.06
	Fund Expense Sub Totals:	3,835,000.00	319,583.33	639,166.66	3,195,833.34	0.00	3,195,833.34	83.33
	Fund 002 Sub Totals:	0.00	-67,915.44	-48,869.42	48,869.42	0.00		

Account Number	Description	Budget Amount	Period Amount	YTD Amount	YTD Var	Encumbered Amount	Available	% Available
Fund 003	Franchise Fees							
Dept 003-0100	Administration							
R50	Sale of Services							
003-0100-4502	AT&T / SW Bell Franchise Fee	125,000.00	29,612.46	29,612.46	95,387.54	0.00	95,387.54	76.31
003-0100-4506	Centerpoint Energy Franchise Fee	200,000.00	42,377.91	74,003.45	125,996.55	0.00	125,996.55	63.00
003-0100-4508	Fidelity Franchise Fee	15,000.00	11,918.51	11,918.51	3,081.49	0.00	3,081.49	20.54
003-0100-4510	Comcast Cable Franchise Fee	75,000.00	19,672.80	19,672.80	55,327.20	0.00	55,327.20	73.77
003-0100-4526	Entergy Franchise Fee	500,000.00	44,822.22	86,055.24	413,944.76	0.00	413,944.76	82.79
003-0100-4528	First Electric Franchise Fee	250,000.00	24,823.23	47,661.85	202,338.15	0.00	202,338.15	80.94
003-0100-4564	Windstream Franchise Fee	0.00	0.00	0.00	0.00	0.00	0.00	0.00
R50 Sub Totals:		1,165,000.00	173,227.13	268,924.31	896,075.69	0.00	896,075.69	76.92
R85	Interest Revenue							
003-0100-4850	Interest Revenue	120.00	22.59	44.70	75.30	0.00	75.30	62.75
R85 Sub Totals:		120.00	22.59	44.70	75.30	0.00	75.30	62.75
E62	Revenue Sub Totals:	1,165,120.00	173,249.72	268,969.01	896,150.99	0.00	896,150.99	76.91
003-0100-5620	Intergovernmental Tsfr							
003-0100-5622	Xfer to General	420,120.00	0.00	0.00	420,120.00	0.00	420,120.00	100.00
	Xfer to Street	360,000.00	29,298.75	58,597.50	301,402.50	0.00	301,402.50	83.72
E62 Sub Totals:		780,120.00	29,298.75	58,597.50	721,522.50	0.00	721,522.50	92.49
E62	Expense Sub Totals:	780,120.00	29,298.75	58,597.50	721,522.50	0.00	721,522.50	92.49
Dept 003-0400	Dept 0100 Sub Totals:	-385,000.00	-143,950.97	-210,371.51	-174,628.49	0.00		
E62	Intergovernmental Tsfr							
003-0400-5626	Xfer to Other	385,000.00	29,747.30	59,322.30	325,677.70	297,473.00	28,204.70	7.33
E62 Sub Totals:		385,000.00	29,747.30	59,322.30	325,677.70	297,473.00	28,204.70	7.33
E62	Expense Sub Totals:	385,000.00	29,747.30	59,322.30	325,677.70	297,473.00	28,204.70	7.33
Dept 0400 Sub Totals:		385,000.00	29,747.30	59,322.30	325,677.70	297,473.00		
Fund Revenue Sub Totals:		1,165,120.00	173,249.72	268,969.01	896,150.99	0.00	896,150.99	76.91
Fund Expense Sub Totals:		1,165,120.00	59,046.05	117,919.80	1,047,200.20	297,473.00	749,727.20	64.35
Fund 003 Sub Totals:		0.00	-114,203.67	-151,049.21	151,049.21	297,473.00		

Account Number	Description	Budget Amount	Period Amount	YTD Amount	YTD Var	Encumbered Amount	Available	% Available
Fund 005	Designated Tax Fund - Gen'l							
Dept 005-0100	Administration							
R85	Interest Revenue							
005-0100-4850	Interest Revenue	250.00	51.28	107.02	142.98	0.00	142.98	57.19
	R85 Sub Totals:	250.00	51.28	107.02	142.98	0.00	142.98	57.19
	Revenue Sub Totals:	250.00	51.28	107.02	142.98	0.00	142.98	57.19
Dept 005-0200	Dept 0100 Sub Totals:	-250.00	-51.28	-107.02	-142.98	0.00		
R10	Animal Control							
005-0200-4100	Taxes - Sales							
	Designated Tax - AC	383,000.00	38,757.62	68,824.96	314,175.04	0.00	314,175.04	82.03
	R10 Sub Totals:	383,000.00	38,757.62	68,824.96	314,175.04	0.00	314,175.04	82.03
	Revenue Sub Totals:	383,000.00	38,757.62	68,824.96	314,175.04	0.00	314,175.04	82.03
E62	Intergovernmental Tsfr							
005-0200-5620	Xfer to General - AC	383,000.00	31,916.66	63,833.32	319,166.68	0.00	319,166.68	83.33
	E62 Sub Totals:	383,000.00	31,916.66	63,833.32	319,166.68	0.00	319,166.68	83.33
	Expense Sub Totals:	383,000.00	31,916.66	63,833.32	319,166.68	0.00	319,166.68	83.33
Dept 005-0400	Dept 0200 Sub Totals:	0.00	-6,840.96	-4,991.64	4,991.64	0.00		
R10	Parks General							
005-0400-4100	Taxes - Sales							
	Designated Tax - Park	383,000.00	38,757.62	68,824.96	314,175.04	0.00	314,175.04	82.03
	R10 Sub Totals:	383,000.00	38,757.62	68,824.96	314,175.04	0.00	314,175.04	82.03
	Revenue Sub Totals:	383,000.00	38,757.62	68,824.96	314,175.04	0.00	314,175.04	82.03
E62	Intergovernmental Tsfr							
005-0400-5620	Xfer to General - Park	383,000.00	31,916.66	63,833.32	319,166.68	0.00	319,166.68	83.33
	E62 Sub Totals:	383,000.00	31,916.66	63,833.32	319,166.68	0.00	319,166.68	83.33
	Expense Sub Totals:	383,000.00	31,916.66	63,833.32	319,166.68	0.00	319,166.68	83.33
Dept 005-0500	Dept 0400 Sub Totals:	0.00	-6,840.96	-4,991.64	4,991.64	0.00		
R10	Fire Department							
	Taxes - Sales							

Account Number	Description	Budget Amount	Period Amount	YTD Amount	YTD Var	Encumbered Amount	Available	% Available
005-0500-4100	Designated Tax - Fire	960,000.00	96,894.05	172,062.40	787,937.60	0.00	787,937.60	82.08
	R10 Sub Totals:	960,000.00	96,894.05	172,062.40	787,937.60	0.00	787,937.60	82.08
E62	Revenue Sub Totals:	960,000.00	96,894.05	172,062.40	787,937.60	0.00	787,937.60	82.08
005-0500-5620	Intergovernmental Tsfr							
	Xfer to General - Fire	960,000.00	80,000.00	160,000.00	800,000.00	0.00	800,000.00	83.33
	E62 Sub Totals:	960,000.00	80,000.00	160,000.00	800,000.00	0.00	800,000.00	83.33
	Expense Sub Totals:	960,000.00	80,000.00	160,000.00	800,000.00	0.00	800,000.00	83.33
Dept 005-0600	Dept 0500 Sub Totals:	0.00	-16,894.05	-12,062.40	12,062.40	0.00		
R10	Police							
005-0600-4100	Taxes - Sales	960,000.00	96,894.05	172,062.40	787,937.60	0.00	787,937.60	82.08
	Designated Tax - Police	960,000.00	96,894.05	172,062.40	787,937.60	0.00	787,937.60	82.08
	R10 Sub Totals:	960,000.00	96,894.05	172,062.40	787,937.60	0.00	787,937.60	82.08
E62	Revenue Sub Totals:	960,000.00	96,894.05	172,062.40	787,937.60	0.00	787,937.60	82.08
005-0600-5620	Intergovernmental Tsfr							
	Xfer to General - Police	960,000.00	80,000.00	160,000.00	800,000.00	0.00	800,000.00	83.33
	E62 Sub Totals:	960,000.00	80,000.00	160,000.00	800,000.00	0.00	800,000.00	83.33
	Expense Sub Totals:	960,000.00	80,000.00	160,000.00	800,000.00	0.00	800,000.00	83.33
Dept 005-0800	Dept 0600 Sub Totals:	0.00	-16,894.05	-12,062.40	12,062.40	0.00		
R10	Street							
005-0800-4100	Taxes - Sales	1,440,000.00	116,272.87	206,474.92	1,233,525.08	0.00	1,233,525.08	85.66
	Designated Tax - Street	1,440,000.00	116,272.87	206,474.92	1,233,525.08	0.00	1,233,525.08	85.66
	R10 Sub Totals:	1,440,000.00	116,272.87	206,474.92	1,233,525.08	0.00	1,233,525.08	85.66
E62	Revenue Sub Totals:	1,440,000.00	116,272.87	206,474.92	1,233,525.08	0.00	1,233,525.08	85.66
005-0800-5620	Intergovernmental Tsfr							
	Xfer to Street	1,073,000.00	89,416.66	178,833.32	894,166.68	0.00	894,166.68	83.33
	E62 Sub Totals:	1,073,000.00	89,416.66	178,833.32	894,166.68	0.00	894,166.68	83.33
	Expense Sub Totals:	1,073,000.00	89,416.66	178,833.32	894,166.68	0.00	894,166.68	83.33

Account Number	Description	Budget Amount	Period Amount	YTD Amount	YTD Var	Encumbered Amount	Available	% Available
	Dept 0800 Sub Totals:	-367,000.00	-26,856.21	-27,641.60	-339,358.40	0.00		
	Fund Revenue Sub Totals:	4,126,250.00	387,627.49	688,356.66	3,437,893.34	0.00	3,437,893.34	83.32
	Fund Expense Sub Totals:	3,759,000.00	313,249.98	626,499.96	3,132,500.04	0.00	3,132,500.04	83.33
	Fund 005 Sub Totals:	-367,250.00	-74,377.51	-61,856.70	-305,393.30	0.00		

Account Number	Description	Budget Amount	Period Amount	YTD Amount	YTD Var	Encumbered Amount	Available	% Available
Fund 020	Animal Control Donation							
Dept 020-0200								
R68	Donation Revenue	4,500.00	817.01	817.01	3,682.99	0.00	3,682.99	81.84
020-0200-4680	Donation Revenue	5,000.00	20.00	20.00	4,980.00	0.00	4,980.00	99.60
020-0200-4682	Donations Dog Park							
R68 Sub Totals:		9,500.00	837.01	837.01	8,662.99	0.00	8,662.99	91.19
R85	Interest Revenue	0.00	0.37	0.77	-0.77	0.00	-0.77	0.00
020-0200-4850	Interest Revenue	0.00	0.37	0.77	-0.77	0.00	-0.77	0.00
R85 Sub Totals:		0.00	0.37	0.77	-0.77	0.00	-0.77	0.00
Revenue Sub Totals:		9,500.00	837.38	837.78	8,662.22	0.00	8,662.22	91.18
Donation Expense								
AC Donation Expense		9,500.00	0.00	0.00	9,500.00	0.00	9,500.00	100.00
E68		9,500.00	0.00	0.00	9,500.00	0.00	9,500.00	100.00
020-0200-5580		9,500.00	0.00	0.00	9,500.00	0.00	9,500.00	100.00
E68 Sub Totals:		9,500.00	0.00	0.00	9,500.00	0.00	9,500.00	100.00
Expense Sub Totals:		0.00	-837.38	-837.78	837.78	0.00		
Dept 0200 Sub Totals:		9,500.00	837.38	837.78	8,662.22	0.00	8,662.22	91.18
Fund Revenue Sub Totals:		9,500.00	837.38	837.78	8,662.22	0.00	8,662.22	91.18
Fund Expense Sub Totals:		9,500.00	0.00	0.00	9,500.00	0.00	9,500.00	100.00
Fund 020 Sub Totals:		0.00	-837.38	-837.78	837.78	0.00		

Account Number	Description	Budget Amount	Period Amount	YTD Amount	YTD Var	Encumbered Amount	Available	% Available
Fund 030	Act 1256 of 1995 Court							
Dept 030-0300								
R40	Fines & Forfeitures							
030-0300-4404	Act 1256 Civil Division	71,250.00	4,160.00	7,215.00	64,035.00	0.00	64,035.00	89.87
030-0300-4406	Act 1256 District Court Rev	360,000.00	22,463.30	50,512.60	309,487.40	0.00	309,487.40	85.97
	R40 Sub Totals:	431,250.00	26,623.30	57,727.60	373,522.40	0.00	373,522.40	86.61
	Revenue Sub Totals:	431,250.00	26,623.30	57,727.60	373,522.40	0.00	373,522.40	86.61
E01	Personnel Expense							
030-0300-5072	Act 1256 Judge Retirement	5,200.00	394.84	782.70	4,417.30	0.00	4,417.30	84.95
	E01 Sub Totals:	5,200.00	394.84	782.70	4,417.30	0.00	4,417.30	84.95
E40	Operations Expense							
030-0300-5400	Act 316 of 1991 Expense	250.00	18.52	36.32	213.68	0.00	213.68	85.47
030-0300-5415	Act 918 of 1983 Expncsc	17,500.00	1,342.64	2,661.54	14,838.46	0.00	14,838.46	84.79
030-0300-5425	Act 1256 Co Admin of Justice	140,500.00	10,741.60	21,293.27	119,206.73	0.00	119,206.73	84.84
030-0300-5430	Act 1256 Court Costs	15,250.00	1,181.04	2,341.20	12,908.80	0.00	12,908.80	84.65
030-0300-5435	Act 1256 City Attorney	28,500.00	2,190.68	4,342.62	24,157.38	0.00	24,157.38	84.76
030-0300-5440	Act 1256 DFA (State)	197,250.00	8,720.64	22,238.83	175,011.17	0.00	175,011.17	88.73
030-0300-5445	Act 1256 Ordinance 89-15	26,000.00	1,966.60	3,898.43	22,101.57	0.00	22,101.57	85.01
030-0300-5495	Act 1256 Intoximeter Expense	900.00	67.14	133.09	766.91	0.00	766.91	85.21
	E40 Sub Totals:	426,150.00	26,228.86	56,945.30	369,204.70	0.00	369,204.70	86.64
	Expense Sub Totals:	431,350.00	26,623.70	57,728.00	373,622.00	0.00	373,622.00	86.62
	Dept 0300 Sub Totals:	100.00	0.40	0.40	99.60	0.00		
	Fund Revenue Sub Totals:	431,250.00	26,623.30	57,727.60	373,522.40	0.00	373,522.40	86.61
	Fund Expense Sub Totals:	431,350.00	26,623.70	57,728.00	373,622.00	0.00	373,622.00	86.62
	Fund 030 Sub Totals:	100.00	0.40	0.40	99.60	0.00		

Account Number	Description	Budget Amount	Period Amount	YTD Amount	YTD Var	Encumbered Amount	Available	% Available
Fund 031	Act 1809 of 2001 Court Auto							
Dept 031-0300	Fines & Forfeitures							
R40	Act 1809 of 2001 Revenue	26,000.00	3,153.70	6,136.40	19,863.60	0.00	19,863.60	76.40
031-0300-4408	R40 Sub Totals:	26,000.00	3,153.70	6,136.40	19,863.60	0.00	19,863.60	76.40
R85	Interest Revenue	0.00	2.33	4.72	-4.72	0.00	-4.72	0.00
031-0300-4850	Interest Revenue	0.00	2.33	4.72	-4.72	0.00	-4.72	0.00
	R85 Sub Totals:	0.00	2.33	4.72	-4.72	0.00	-4.72	0.00
E60	Revenue Sub Totals:	26,000.00	3,156.03	6,141.12	19,858.88	0.00	19,858.88	76.38
031-0300-5608	Miscellaneous Expense	32,250.00	3,721.00	3,721.00	28,529.00	18,605.00	9,924.00	30.77
	Computer Software	32,250.00	3,721.00	3,721.00	28,529.00	18,605.00	9,924.00	30.77
	E60 Sub Totals:	32,250.00	3,721.00	3,721.00	28,529.00	18,605.00	9,924.00	30.77
	Expense Sub Totals:	32,250.00	3,721.00	3,721.00	28,529.00	18,605.00	9,924.00	30.77
	Dept 0300 Sub Totals:	6,250.00	564.97	-2,420.12	8,670.12	18,605.00		
	Fund Revenue Sub Totals:	26,000.00	3,156.03	6,141.12	19,858.88	0.00	19,858.88	76.38
	Fund Expense Sub Totals:	32,250.00	3,721.00	3,721.00	28,529.00	18,605.00	9,924.00	30.77
	Fund 031 Sub Totals:	6,250.00	564.97	-2,420.12	8,670.12	18,605.00		

Account Number	Description	Budget Amount	Period Amount	YTD Amount	YTD Var	Encumbered Amount	Available	% Available
Fund 045	Park 1/8 Sales Tax O & M							
Dept 045-0400	Parks General							
R10	Taxes - Sales							
045-0400-4110	Park 1/8 Sales Tax	480,000.00	48,447.03	86,031.21	393,968.79	0.00	393,968.79	82.08
	R10 Sub Totals:	480,000.00	48,447.03	86,031.21	393,968.79	0.00	393,968.79	82.08
R85	Interest Revenue							
045-0400-4850	Interest Revenue	0.00	1.80	3.97	-3.97	0.00	-3.97	0.00
	R85 Sub Totals:	0.00	1.80	3.97	-3.97	0.00	-3.97	0.00
	Revenue Sub Totals:	480,000.00	48,448.83	86,035.18	393,964.82	0.00	393,964.82	82.08
E62	Intergovernmental Tsfr							
045-0400-5620	Xfer to General	480,000.00	40,000.00	80,000.00	400,000.00	0.00	400,000.00	83.33
	E62 Sub Totals:	480,000.00	40,000.00	80,000.00	400,000.00	0.00	400,000.00	83.33
	Expense Sub Totals:	480,000.00	40,000.00	80,000.00	400,000.00	0.00	400,000.00	83.33
	Dept 0400 Sub Totals:	0.00	-8,448.83	-6,035.18	6,035.18	0.00		
	Fund Revenue Sub Totals:	480,000.00	48,448.83	86,035.18	393,964.82	0.00	393,964.82	82.08
	Fund Expense Sub Totals:	480,000.00	40,000.00	80,000.00	400,000.00	0.00	400,000.00	83.33
	Fund 045 Sub Totals:	0.00	-8,448.83	-6,035.18	6,035.18	0.00		

Account Number	Description	Budget Amount	Period Amount	YTD Amount	YTD Var	Encumbered Amount	Available	% Available
Fund 050	Fire Donation							
Dept 050-0500	Fire Department							
R68	Donation Revenue							
050-0500-4680	Donation Revenue	1,000.00	0.00	286.59	713.41	0.00	713.41	71.34
	R68 Sub Totals:	1,000.00	0.00	286.59	713.41	0.00	713.41	71.34
R85	Interest Revenue							
050-0500-4850	Interest Revenue	0.00	0.10	0.20	-0.20	0.00	-0.20	0.00
	R85 Sub Totals:	0.00	0.10	0.20	-0.20	0.00	-0.20	0.00
	Revenue Sub Totals:	1,000.00	0.10	286.79	713.21	0.00	713.21	71.32
E68	Donation Expense							
050-0500-5580	Donations Expense Fire	1,000.00	0.00	0.00	1,000.00	0.00	1,000.00	100.00
	E68 Sub Totals:	1,000.00	0.00	0.00	1,000.00	0.00	1,000.00	100.00
	Expense Sub Totals:	1,000.00	0.00	0.00	1,000.00	0.00	1,000.00	100.00
	Dept 0500 Sub Totals:	0.00	-0.10	-286.79	286.79	0.00		
	Fund Revenue Sub Totals:	1,000.00	0.10	286.79	713.21	0.00	713.21	71.32
	Fund Expense Sub Totals:	1,000.00	0.00	0.00	1,000.00	0.00	1,000.00	100.00
	Fund 050 Sub Totals:	0.00	-0.10	-286.79	286.79	0.00		

Account Number	Description	Budget Amount	Period Amount	YTD Amount	YTD Var	Encumbered Amount	Available	% Available
Fund 051	Act 833 of 1991 Fire							
Dept 051-0500	Fire Department							
R15	Taxes - Property							
051-0500-4150	State Turnback	15,000.00	0.00	870.23	14,129.77	0.00	14,129.77	94.20
	R15 Sub Totals:	15,000.00	0.00	870.23	14,129.77	0.00	14,129.77	94.20
R85	Interest Revenue							
051-0500-4850	Interest Revenue	0.00	1.17	2.41	-2.41	0.00	-2.41	0.00
	R85 Sub Totals:	0.00	1.17	2.41	-2.41	0.00	-2.41	0.00
	Revenue Sub Totals:	15,000.00	1.17	872.64	14,127.36	0.00	14,127.36	94.18
E40	Operations Expense							
051-0500-5410	Act 833 Expense	15,000.00	624.15	624.15	14,375.85	0.00	14,375.85	95.84
	E40 Sub Totals:	15,000.00	624.15	624.15	14,375.85	0.00	14,375.85	95.84
	Expense Sub Totals:	15,000.00	624.15	624.15	14,375.85	0.00	14,375.85	95.84
	Dept 0500 Sub Totals:	0.00	622.98	-248.49	248.49	0.00		
	Fund Revenue Sub Totals:	15,000.00	1.17	872.64	14,127.36	0.00	14,127.36	94.18
	Fund Expense Sub Totals:	15,000.00	624.15	624.15	14,375.85	0.00	14,375.85	95.84
	Fund 051 Sub Totals:	0.00	622.98	-248.49	248.49	0.00		

Account Number	Description	Budget Amount	Period Amount	YTD Amount	YTD Var	Encumbered Amount	Available	% Available
Fund 055	Fire 3/8 SalesTax							
Dept 055-0500	Fire Department							
R10	Taxes - Sales							
055-0500-4120	Fire 3/8 Sales Tax	1,440,000.00	145,341.07	258,093.60	1,181,906.40	0.00	1,181,906.40	82.08
	R10 Sub Totals:	1,440,000.00	145,341.07	258,093.60	1,181,906.40	0.00	1,181,906.40	82.08
R85	Interest Revenue							
055-0500-4850	Interest Revenue	0.00	10.74	22.62	-22.62	0.00	-22.62	0.00
055-0500-4855	Gain on Investment	0.00	0.00	0.00	0.00	0.00	0.00	0.00
	R85 Sub Totals:	0.00	10.74	22.62	-22.62	0.00	-22.62	0.00
	Revenue Sub Totals:	1,440,000.00	145,351.81	258,116.22	1,181,883.78	0.00	1,181,883.78	82.08
E62	Intergovernmental Tsfr							
055-0500-5620	Xfer to General	1,265,000.00	105,416.66	210,833.32	1,054,166.68	0.00	1,054,166.68	83.33
	E62 Sub Totals:	1,265,000.00	105,416.66	210,833.32	1,054,166.68	0.00	1,054,166.68	83.33
E80	Fixed Assets							
055-0500-5814	Fixed Assets - Fire Trucks	165,000.00	-14,657.84	0.00	165,000.00	96,113.12	68,886.88	41.75
	E80 Sub Totals:	165,000.00	-14,657.84	0.00	165,000.00	96,113.12	68,886.88	41.75
E85	Interest Expense							
055-0500-5850	Interest Expense	11,010.27	0.00	0.00	11,010.27	5,697.32	5,312.95	48.25
	E85 Sub Totals:	11,010.27	0.00	0.00	11,010.27	5,697.32	5,312.95	48.25
	Expense Sub Totals:	1,441,010.27	90,758.82	210,833.32	1,230,176.95	101,810.44	1,128,366.51	78.30
	Dept 0500 Sub Totals:	1,010.27	-54,592.99	-47,282.90	48,293.17	101,810.44		
	Fund Revenue Sub Totals:	1,440,000.00	145,351.81	258,116.22	1,181,883.78	0.00	1,181,883.78	82.08
	Fund Expense Sub Totals:	1,441,010.27	90,758.82	210,833.32	1,230,176.95	101,810.44	1,128,366.51	78.30
	Fund 055 Sub Totals:	1,010.27	-54,592.99	-47,282.90	48,293.17	101,810.44		

Account Number	Description	Budget Amount	Period Amount	YTD Amount	YTD Var	Encumbered Amount	Available	% Available
Fund 059	Firemen's Pension							
Dept 059-0500	Fire Department							
R64	Reimbursement							
059-0500-4645	LOPFI Subsidy	7,500.00	0.00	0.00	7,500.00	0.00	7,500.00	100.00
	R64 Sub Totals:	7,500.00	0.00	0.00	7,500.00	0.00	7,500.00	100.00
R85	Interest Revenue							
059-0500-4850	Interest Revenue	0.00	216.35	534.30	-534.30	0.00	-534.30	0.00
059-0500-4855	Gain on Investment	0.00	18.48	42.21	-42.21	0.00	-42.21	0.00
	R85 Sub Totals:	0.00	234.83	576.51	-576.51	0.00	-576.51	0.00
	Revenue Sub Totals:	7,500.00	234.83	576.51	6,923.49	0.00	6,923.49	92.31
E01	Personnel Expense							
059-0500-5038	Pension Expense	2,000.00	1,210.00	2,420.00	-420.00	0.00	-420.00	0.00
059-0500-5039	Pension Expense - Misc Exp	14,500.00	0.00	358.80	14,141.20	0.00	14,141.20	97.53
	E01 Sub Totals:	16,500.00	1,210.00	2,778.80	13,721.20	0.00	13,721.20	83.16
E85	Interest Expense							
059-0500-5855	Loss on Investment	0.00	0.00	16.75	-16.75	0.00	-16.75	0.00
	E85 Sub Totals:	0.00	0.00	16.75	-16.75	0.00	-16.75	0.00
	Expense Sub Totals:	16,500.00	1,210.00	2,795.55	13,704.45	0.00	13,704.45	83.06
	Dept 0500 Sub Totals:	9,000.00	975.17	2,219.04	6,780.96	0.00		
	Fund Revenue Sub Totals:	7,500.00	234.83	576.51	6,923.49	0.00	6,923.49	92.31
	Fund Expense Sub Totals:	16,500.00	1,210.00	2,795.55	13,704.45	0.00	13,704.45	83.06
	Fund 059 Sub Totals:	9,000.00	975.17	2,219.04	6,780.96	0.00		

Account Number	Description	Budget Amount	Period Amount	YTD Amount	YTD Var	Encumbered Amount	Available	% Available
Fund 060	Police Donation							
Dept 060-0600	Police							
R68	Donation Revenue							
060-0600-4680	Donation Revenue	1,000.00	0.00	0.00	1,000.00	0.00	1,000.00	100.00
	R68 Sub Totals:	1,000.00	0.00	0.00	1,000.00	0.00	1,000.00	100.00
R85	Interest Revenue							
060-0600-4850	Interest Revenue	0.00	0.07	0.14	-0.14	0.00	-0.14	0.00
	R85 Sub Totals:	0.00	0.07	0.14	-0.14	0.00	-0.14	0.00
	Revenue Sub Totals:	1,000.00	0.07	0.14	999.86	0.00	999.86	99.99
E60	Miscellaneous Expense							
060-0600-5600	Miscellaneous Expense	1,000.00	0.00	0.00	1,000.00	0.00	1,000.00	100.00
	E60 Sub Totals:	1,000.00	0.00	0.00	1,000.00	0.00	1,000.00	100.00
	Expense Sub Totals:	1,000.00	0.00	0.00	1,000.00	0.00	1,000.00	100.00
	Dept 0600 Sub Totals:	0.00	-0.07	-0.14	0.14	0.00		
	Fund Revenue Sub Totals:	1,000.00	0.07	0.14	999.86	0.00	999.86	99.99
	Fund Expense Sub Totals:	1,000.00	0.00	0.00	1,000.00	0.00	1,000.00	100.00
	Fund 060 Sub Totals:	0.00	-0.07	-0.14	0.14	0.00		

Account Number	Description	Budget Amount	Period Amount	YTD Amount	YTD Var	Encumbered Amount	Available	% Available
Fund 061	Act 918 of 1983 Police							
Dept 061-0600	Police							
R40	Fines & Forfeitures							
061-0600-4410	Admin of Justice Revenue	20,000.00	1,342.64	2,661.54	17,338.46	0.00	17,338.46	86.69
	R40 Sub Totals:	20,000.00	1,342.64	2,661.54	17,338.46	0.00	17,338.46	86.69
R85	Interest Revenue	0.00	1.00	2.02	-2.02	0.00	-2.02	0.00
061-0600-4850	Interest Revenue	0.00	1.00	2.02	-2.02	0.00	-2.02	0.00
	R85 Sub Totals:							
	Revenue Sub Totals:	20,000.00	1,343.64	2,663.56	17,336.44	0.00	17,336.44	86.68
E40	Operations Expense							
061-0600-5415	Act 918 of 1983 Expense	20,000.00	0.00	0.00	20,000.00	0.00	20,000.00	100.00
	E40 Sub Totals:	20,000.00	0.00	0.00	20,000.00	0.00	20,000.00	100.00
	Expense Sub Totals:	20,000.00	0.00	0.00	20,000.00	0.00	20,000.00	100.00
	Dept 0600 Sub Totals:	0.00	-1,343.64	-2,663.56	2,663.56	0.00		
	Fund Revenue Sub Totals:	20,000.00	1,343.64	2,663.56	17,336.44	0.00	17,336.44	86.68
	Fund Expense Sub Totals:	20,000.00	0.00	0.00	20,000.00	0.00	20,000.00	100.00
	Fund 061 Sub Totals:	0.00	-1,343.64	-2,663.56	2,663.56	0.00		

Account Number	Description	Budget Amount	Period Amount	YTD Amount	YTD Var	Encumbered Amount	Available	% Available
Fund 062	Act 988 of 1991 Emerg Veh							
Dept 062-0600	Police							
R40	Fines & Forfeitures							
062-0600-4402	Act 988 of 1991 Revenue	20,000.00	1,081.00	2,284.00	17,716.00	0.00	17,716.00	88.58
	R40 Sub Totals:	20,000.00	1,081.00	2,284.00	17,716.00	0.00	17,716.00	88.58
R85	Interest Revenue							
062-0600-4850	Interest Revenue	0.00	0.93	1.88	-1.88	0.00	-1.88	0.00
	R85 Sub Totals:	0.00	0.93	1.88	-1.88	0.00	-1.88	0.00
	Revenue Sub Totals:	20,000.00	1,081.93	2,285.88	17,714.12	0.00	17,714.12	88.57
E40	Operations Expense							
062-0600-5420	Act 988 Expense	20,000.00	0.00	0.00	20,000.00	0.00	20,000.00	100.00
	E40 Sub Totals:	20,000.00	0.00	0.00	20,000.00	0.00	20,000.00	100.00
	Expense Sub Totals:	20,000.00	0.00	0.00	20,000.00	0.00	20,000.00	100.00
	Dept 0600 Sub Totals:	0.00	-1,081.93	-2,285.88	2,285.88	0.00		
	Fund Revenue Sub Totals:	20,000.00	1,081.93	2,285.88	17,714.12	0.00	17,714.12	88.57
	Fund Expense Sub Totals:	20,000.00	0.00	0.00	20,000.00	0.00	20,000.00	100.00
	Fund 062 Sub Totals:	0.00	-1,081.93	-2,285.88	2,285.88	0.00		

Account Number	Description	Budget Amount	Period Amount	YTD Amount	YTD Var	Encumbered Amount	Available	% Available
Fund 068	State Drug Control							
Dept 068-0600	Police							
R40	Fines & Forfeitures							
068-0600-4418	Drug Seizure Revenue	5,000.00	0.00	0.00	5,000.00	0.00	5,000.00	100.00
	R40 Sub Totals:	5,000.00	0.00	0.00	5,000.00	0.00	5,000.00	100.00
R85	Interest Revenue							
068-0600-4850	Interest Revenue	0.00	0.32	0.66	-0.66	0.00	-0.66	0.00
	R85 Sub Totals:	0.00	0.32	0.66	-0.66	0.00	-0.66	0.00
	Revenue Sub Totals:	5,000.00	0.32	0.66	4,999.34	0.00	4,999.34	99.99
E60	Miscellaneous Expense							
068-0600-5600	Miscellaneous Expense	5,000.00	25.00	50.00	4,950.00	0.00	4,950.00	99.00
	E60 Sub Totals:	5,000.00	25.00	50.00	4,950.00	0.00	4,950.00	99.00
	Expense Sub Totals:	5,000.00	25.00	50.00	4,950.00	0.00	4,950.00	99.00
	Dept 0600 Sub Totals:	0.00	24.68	49.34	-49.34	0.00		
	Fund Revenue Sub Totals:	5,000.00	0.32	0.66	4,999.34	0.00	4,999.34	99.99
	Fund Expense Sub Totals:	5,000.00	25.00	50.00	4,950.00	0.00	4,950.00	99.00
	Fund 068 Sub Totals:	0.00	24.68	49.34	-49.34	0.00		

Account Number	Description	Budget Amount	Period Amount	YTD Amount	YTD Var	Encumbered Amount	Available	% Available
Fund 080	Street Fund							
Dept 080-0140								
E01	Personnel Expense							
080-0140-5000	Salary Expense	82,015.23	6,266.12	15,640.83	66,374.40	0.00	66,374.40	80.93
080-0140-5010	Overtime Expense	1,000.00	0.00	0.00	1,000.00	0.00	1,000.00	100.00
080-0140-5020	FICA Expense	6,350.67	469.61	1,177.04	5,173.63	0.00	5,173.63	81.47
080-0140-5022	Unemployment Expense	1,080.00	0.00	118.32	961.68	0.00	961.68	89.04
080-0140-5025	Worker's Comp Expense	500.00	188.22	188.22	311.78	0.00	311.78	62.36
080-0140-5030	APERS Expense	12,352.67	924.88	2,308.60	10,044.07	0.00	10,044.07	81.31
080-0140-5040	Health Insurance Expense	22,700.00	1,891.64	3,783.28	18,916.72	0.00	18,916.72	83.33
080-0140-5050	Physical & Drug Screen Exp	300.00	0.00	0.00	300.00	0.00	300.00	100.00
080-0140-5055	Uniform Expense	1,200.00	244.16	244.16	955.84	386.83	569.01	47.42
080-0140-5060	Travel & Training Expense	2,600.00	0.00	0.00	2,600.00	345.00	2,255.00	86.73
E01 Sub Totals:		130,098.57	9,984.63	23,460.45	106,638.12	731.83	105,906.29	81.40
E10	Building & Grounds Exp							
080-0140-5115	Communication Exp - Telephone	700.00	0.00	27.64	672.36	0.00	672.36	96.05
080-0140-5116	Comm Exp - Cellular	1,060.00	27.69	27.69	1,032.31	0.00	1,032.31	97.39
E10 Sub Totals:		1,760.00	27.69	55.33	1,704.67	0.00	1,704.67	96.86
E20	Vehicle Expense							
080-0140-5200	Fuel Expense	6,000.00	272.84	429.97	5,570.03	0.00	5,570.03	92.83
080-0140-5210	Service & Repair - Vehicle	2,000.00	0.00	0.00	2,000.00	238.35	1,761.65	88.08
080-0140-5218	Tire Expense	1,000.00	0.00	0.00	1,000.00	0.00	1,000.00	100.00
080-0140-5225	Insurance Expense - Vehicle	1,750.00	0.00	437.50	1,312.50	0.00	1,312.50	75.00
E20 Sub Totals:		10,750.00	272.84	867.47	9,882.53	238.35	9,644.18	89.71
E30	Supply Expense							
080-0140-5300	Office Supplies	150.00	0.00	0.00	150.00	0.00	150.00	100.00
080-0140-5380	Prisoner Care Expense	1,500.00	0.00	0.00	1,500.00	0.00	1,500.00	100.00
E30 Sub Totals:		1,650.00	0.00	0.00	1,650.00	0.00	1,650.00	100.00
E40	Operations Expense							
080-0140-5520	Public Education Expense	1,000.00	0.00	0.00	1,000.00	0.00	1,000.00	100.00
E40 Sub Totals:		1,000.00	0.00	0.00	1,000.00	0.00	1,000.00	100.00
E55	Professional Services							
080-0140-5571	Prof Services - Engineering	0.00	0.00	0.00	0.00	0.00	0.00	0.00
080-0140-5574	Prof Services - GIS	6,120.00	0.00	0.00	6,120.00	0.00	6,120.00	100.00
080-0140-5576	Prof Services - Engineer	18,360.00	1,530.00	2,380.17	15,979.83	0.00	15,979.83	87.04
080-0140-5589	Prof Services - Printing	200.00	20.00	20.00	180.00	0.00	180.00	90.00
E55 Sub Totals:		24,680.00	1,550.00	2,400.17	22,279.83	0.00	22,279.83	90.27

Account Number	Description	Budget Amount	Period Amount	YTD Amount	YTD Var	Encumbered Amount	Available	% Available
	Expense Sub Totals:	169,938.57	11,835.16	26,783.42	143,155.15	970.18	142,184.97	83.67
Dept 080-0800								
R10	Dept 0140 Sub Totals:	169,938.57	11,835.16	26,783.42	143,155.15	970.18		
080-0800-4152	Taxes - Sales							
	1/2 Cent Sales Tax	275,000.00	28,036.12	54,563.46	220,436.54	0.00	220,436.54	80.16
R15	R10 Sub Totals:	275,000.00	28,036.12	54,563.46	220,436.54	0.00	220,436.54	80.16
080-0800-4150	Taxes - Property							
080-0800-4151	State Turnback	1,080,000.00	60,678.74	124,917.88	955,082.12	0.00	955,082.12	88.43
	Saline County Treasurer	380,000.00	6,700.85	19,965.26	360,034.74	0.00	360,034.74	94.75
R15 Sub Totals:		1,460,000.00	67,379.59	144,883.14	1,315,116.86	0.00	1,315,116.86	90.08
R62	Intergovernmental Tsfrs							
080-0800-4627	Xfer Designated Tax - Street	1,073,000.00	89,516.66	178,933.32	894,066.68	0.00	894,066.68	83.32
R85	R62 Sub Totals:	1,073,000.00	89,516.66	178,933.32	894,066.68	0.00	894,066.68	83.32
	Interest Revenue							
080-0800-4850	Interest Revenue	100.00	52.11	107.60	-7.60	0.00	-7.60	0.00
R85 Sub Totals:		100.00	52.11	107.60	-7.60	0.00	-7.60	0.00
Revenue Sub Totals:		2,808,100.00	184,984.48	378,487.52	2,429,612.48	0.00	2,429,612.48	86.52
E01	Personnel Expense							
080-0800-5000	Salary Expense	414,241.93	30,501.30	76,771.06	337,470.87	0.00	337,470.87	81.47
080-0800-5005	SWB Reimbursement	109,000.00	9,083.33	9,083.33	99,916.67	9,083.33	90,833.34	83.33
080-0800-5010	Overtime Expense	15,000.00	2,738.02	3,020.42	11,979.58	0.00	11,979.58	79.86
080-0800-5020	FICA Expense	32,837.05	2,496.81	6,007.27	26,829.78	0.00	26,829.78	81.71
080-0800-5022	Unemployment Expense	5,550.00	0.00	0.00	5,550.00	0.00	5,550.00	100.00
080-0800-5025	Worker's Comp Expense	18,500.00	0.00	18,284.69	215.31	0.00	215.31	1.16
080-0800-5030	APERS Expense	63,735.26	4,906.16	11,777.30	51,957.96	0.00	51,957.96	81.52
080-0800-5040	Health Insurance Expense	94,955.04	7,971.12	16,024.53	78,930.51	0.00	78,930.51	83.12
080-0800-5050	Physical & Drug Screen Exp	2,000.00	0.00	0.00	2,000.00	150.00	1,850.00	92.50
080-0800-5055	Uniform Expense	6,000.00	112.02	112.02	5,887.98	392.81	5,495.17	91.59
080-0800-5060	Travel & Training Expense	3,500.00	125.00	125.00	3,375.00	100.00	3,275.00	93.57
E01 Sub Totals:		765,319.28	57,933.76	141,205.62	624,113.66	9,726.14	614,387.52	80.28
E10	Building & Grounds Exp							
080-0800-5102	Repairs & Maint - Building	4,500.00	196.43	196.43	4,303.57	196.81	4,106.76	91.26
080-0800-5110	Utilities - Electric	16,000.00	1,447.79	2,441.38	13,558.62	0.00	13,558.62	84.74
080-0800-5111	Utilities - Gas	2,950.00	515.60	877.87	2,072.13	0.00	2,072.13	70.24
080-0800-5112	Utilities - Water	1,000.00	26.46	52.92	947.08	0.00	947.08	94.71

Account Number	Description	Budget Amount	Period Amount	YTD Amount	YTD Var	Encumbered Amount	Available	% Available
080-0800-5115	Communication Exp - Telephone	8,500.00	377.39	544.95	7,955.05	377.33	7,577.72	89.15
080-0800-5116	Communication Exp - Cellular	5,000.00	244.09	491.77	4,508.23	0.00	4,508.23	90.16
080-0800-5120	Insurance - Property	2,500.00	0.00	0.00	2,500.00	0.00	2,500.00	100.00
080-0800-5130	Sanitation	2,500.00	0.00	197.99	2,302.01	39.63	2,262.38	90.50
080-0800-5140	Supplies - B&G	2,600.00	0.00	0.00	2,600.00	222.46	2,377.54	91.44
080-0800-5145	Tools	10,000.00	1,778.62	1,778.62	8,221.38	308.03	7,913.35	79.13
E10 Sub Totals:		55,550.00	4,586.38	6,581.93	48,968.07	1,144.26	47,823.81	86.09
E20	Vehicle Expense							
080-0800-5200	Fuel Expense	70,000.00	2,801.30	5,623.58	64,376.42	678.00	63,698.42	91.00
080-0800-5210	Service & Repair - Vehicle	65,000.00	4,397.42	4,673.06	60,326.94	4,027.96	56,298.98	86.61
080-0800-5218	Tire Expense	10,000.00	1,462.07	1,462.07	8,537.93	0.00	8,537.93	85.38
080-0800-5225	Insurance Expense - Vehicle	13,650.00	0.00	13,641.09	8.91	0.00	8.91	0.07
080-0800-5230	Radios	1,000.00	0.00	0.00	1,000.00	0.00	1,000.00	100.00
080-0800-5240	Equipment Rental	8,000.00	0.00	0.00	8,000.00	0.00	8,000.00	100.00
E20 Sub Totals:		167,650.00	8,660.79	25,399.80	142,250.20	4,705.96	137,544.24	82.04
E30	Supply Expense							
080-0800-5300	Supplies - Office	4,000.00	714.83	714.83	3,285.17	573.67	2,711.50	67.79
080-0800-5316	Supplies - Signs	35,500.00	1,379.70	1,379.70	34,120.30	0.00	34,120.30	96.11
080-0800-5322	Supplies - Operating	4,000.00	64.14	64.14	3,935.86	0.00	3,935.86	98.40
080-0800-5350	Postage Expense	500.00	0.00	0.00	500.00	0.00	500.00	100.00
080-0800-5380	Prisoner Care Expense	2,000.00	0.00	0.00	2,000.00	102.64	1,897.36	94.87
E30 Sub Totals:		46,000.00	2,158.67	2,158.67	43,841.33	676.31	43,165.02	93.84
E40	Operations Expense							
080-0800-5141	Pest/Chem/Seed/Fert	2,000.00	65.70	65.70	1,934.30	0.00	1,934.30	96.72
080-0800-5142	Janitorial Supplies & Services	2,000.00	125.93	251.86	1,748.14	125.93	1,622.21	81.11
080-0800-5323	Material and Maint.	140,000.00	4,663.06	5,022.60	134,977.40	3,834.00	131,143.40	93.67
080-0800-5480	Dues & Subscriptions	4,400.00	0.00	0.00	4,400.00	0.00	4,400.00	100.00
080-0800-5525	Right-of-Way Maintenance	10,000.00	1,000.00	1,000.00	9,000.00	0.00	9,000.00	90.00
080-0800-5530	Safety Program	1,000.00	539.28	539.28	460.72	0.00	460.72	46.07
080-0800-5545	Street Paving Expense	150,000.00	5,453.46	6,163.05	143,836.95	441.14	143,395.81	95.60
080-0800-5546	Street Lights Installed	115,000.00	7,663.71	14,939.20	100,060.80	0.00	100,060.80	87.01
080-0800-5547	Traffic Signal Maintenance	25,000.00	0.00	881.53	24,118.47	0.00	24,118.47	96.47
E40 Sub Totals:		449,400.00	19,511.14	28,863.22	420,536.78	4,401.07	416,135.71	92.60
E55	Professional Services							
080-0800-5553	Prof Services - Advertising	2,500.00	0.00	176.90	2,323.10	0.00	2,323.10	92.92
080-0800-5562	Prof Services - Bridge Inspection	1,000.00	65.57	65.57	934.43	0.00	934.43	93.44
080-0800-5571	Prof Services - Engineering	12,240.00	1,020.00	2,153.22	10,086.78	0.00	10,086.78	82.41
080-0800-5574	Prof Services - GIS	6,120.00	0.00	0.00	6,120.00	0.00	6,120.00	100.00
080-0800-5586	Prof Services - Other	120,000.00	2,664.99	2,664.99	117,335.01	0.00	117,335.01	97.78
080-0800-5589	Prof Services - Printing	600.00	67.70	67.70	532.30	0.00	532.30	88.72

Account Number	Description	Budget Amount	Period Amount	YTD Amount	YTD Var	Encumbered Amount	Available	% Available
E55 Sub Totals:		142,460.00	3,818.26	5,128.38	137,331.62	0.00	137,331.62	96.40
E60	Miscellaneous Expense							
080-0800-5600	Miscellaneous Expense	5,000.00	0.00	0.00	5,000.00	0.00	5,000.00	100.00
080-0800-5604	Computer Hardware	4,000.00	0.00	0.00	4,000.00	0.00	4,000.00	100.00
080-0800-5606	Computer Maint & Support	1,000.00	0.00	0.00	1,000.00	329.93	670.07	67.01
080-0800-5608	Computer Software	2,500.00	0.00	0.00	2,500.00	0.00	2,500.00	100.00
E60 Sub Totals:		12,500.00	0.00	0.00	12,500.00	329.93	12,170.07	97.36
E80	Fixed Assets							
080-0800-5808	Fixed Assets - Other Equipment	371,000.00	0.00	0.00	371,000.00	33,591.75	337,408.25	90.95
080-0800-5810	Fixed Assets - Equipment	1,000.00	0.00	0.00	1,000.00	0.00	1,000.00	100.00
080-0800-5828	Project - Snooks Lane	331,000.00	0.00	0.00	331,000.00	0.00	331,000.00	100.00
E80 Sub Totals:		703,000.00	0.00	0.00	703,000.00	33,591.75	669,408.25	95.22
E85	Interest Expense							
080-0800-5816	Fixed Assets - Infrastructure	0.00	0.00	0.00	0.00	0.00	0.00	0.00
E85 Sub Totals:		0.00	0.00	0.00	0.00	0.00	0.00	0.00
E90	Construction Projects							
080-0800-5904	Fixed Asse Whistling Pine Drain	210,000.00	0.00	0.00	210,000.00	0.00	210,000.00	100.00
080-0800-5910	Project - Overlay 2013	400,000.00	0.00	0.00	400,000.00	0.00	400,000.00	100.00
E90 Sub Totals:		610,000.00	0.00	0.00	610,000.00	0.00	610,000.00	100.00
Expense Sub Totals:		2,951,879.28	96,669.00	209,337.62	2,742,541.66	54,575.42	2,687,966.24	91.06
Dept 0800 Sub Totals:		143,779.28	-88,315.48	-169,149.90	312,929.18	54,575.42		
Fund Revenue Sub Totals:		2,808,100.00	184,984.48	378,487.52	2,429,612.48	0.00	2,429,612.48	86.52
Fund Expense Sub Totals:		3,121,817.85	108,504.16	236,121.04	2,885,696.81	55,545.60	2,830,151.21	90.66
Fund 080 Sub Totals:		313,717.85	-76,480.32	-142,366.48	456,084.33	55,545.60		

Account Number	Description	Budget Amount	Period Amount	YTD Amount	YTD Var	Encumbered Amount	Available	% Available
Fund 140	Park Bond 2006 DS							
Dept 140-0400	Parks General							
R10	Taxes - Sales							
140-0400-4111	Park Bond Sales Tax	96,894.05	96,894.05	172,062.41	787,937.59	0.00	787,937.59	82.08
	R10 Sub Totals:	96,894.05	96,894.05	172,062.41	787,937.59	0.00	787,937.59	82.08
R62	Intergovernmental Tsfrs							
140-0400-4626	Xfer from Other	0.00	0.00	0.02	-0.02	0.00	-0.02	0.00
	R62 Sub Totals:	0.00	0.00	0.02	-0.02	0.00	-0.02	0.00
R85	Interest Revenue							
140-0400-4850	Interest Revenue	0.00	4.26	7.91	-7.91	0.00	-7.91	0.00
140-0400-4855	Gain on Investment	0.00	0.00	0.00	0.00	0.00	0.00	0.00
	R85 Sub Totals:	0.00	4.26	7.91	-7.91	0.00	-7.91	0.00
	Revenue Sub Totals:	96,898.31	96,898.31	172,070.34	787,929.66	0.00	787,929.66	82.08
E72	Bond Expense							
140-0400-5722	Bond Principal Pmt	955,000.00	0.00	0.00	955,000.00	0.00	955,000.00	100.00
140-0400-5724	Bond Fee	5,000.00	0.00	0.00	5,000.00	0.00	5,000.00	100.00
	E72 Sub Totals:	960,000.00	0.00	0.00	960,000.00	0.00	960,000.00	100.00
E85	Interest Expense							
140-0400-5855	Loss on Investment	0.00	0.00	0.00	0.00	0.00	0.00	0.00
	E85 Sub Totals:	0.00	0.00	0.00	0.00	0.00	0.00	0.00
	Expense Sub Totals:	960,000.00	0.00	0.00	960,000.00	0.00	960,000.00	100.00
	Dept 0400 Sub Totals:	0.00	-96,898.31	-172,070.34	172,070.34	0.00		
	Fund Revenue Sub Totals:	960,000.00	96,898.31	172,070.34	787,929.66	0.00	787,929.66	82.08
	Fund Expense Sub Totals:	960,000.00	0.00	0.00	960,000.00	0.00	960,000.00	100.00
	Fund 140 Sub Totals:	0.00	-96,898.31	-172,070.34	172,070.34	0.00		

Account Number	Description	Budget Amount	Period Amount	YTD Amount	YTD Var	Encumbered Amount	Available	% Available
Fund 141	Park Bond 2006 DSR							
Dept 141-0400	Parks General							
R85	Intercrst Revenue	0.00	-0.01	0.01	-0.01	0.00	-0.01	0.00
141-0400-4850	Interest Revenue	0.00	0.00	631.28	-631.28	0.00	-631.28	0.00
141-0400-4855	Gain on Investment							
	R85 Sub Totals:	0.00	-0.01	631.29	-631.29	0.00	-631.29	0.00
	Revenue Sub Totals:							
E62	Intergovernmental Tsfr	0.00	-0.01	631.29	-631.29	0.00	-631.29	0.00
141-0400-5626	Xfer to Other	0.00	0.00	0.02	-0.02	0.00	-0.02	0.00
	E62 Sub Totals:	0.00	0.00	0.02	-0.02	0.00	-0.02	0.00
E85	Interest Expense							
141-0400-5855	Loss on Investment	0.00	658.92	658.92	-658.92	0.00	-658.92	0.00
	E85 Sub Totals:	0.00	658.92	658.92	-658.92	0.00	-658.92	0.00
	Expense Sub Totals:							
	Dept 0400 Sub Totals:	0.00	658.92	658.94	-658.94	0.00	-658.94	0.00
	Fund Revenue Sub Totals:	0.00	658.93	27.65	-27.65	0.00		
	Fund Expense Sub Totals:	0.00	-0.01	631.29	-631.29	0.00	-631.29	0.00
	Fund 141 Sub Totals:	0.00	658.92	658.94	-658.94	0.00	-658.94	0.00
		0.00	658.93	27.65	-27.65	0.00		

Account Number	Description	Budget Amount	Period Amount	YTD Amount	YTD Var	Encumbered Amount	Available	% Available
Fund 142	Park Bond 2006 O&M							
Dept 142-0400	Parks General							
R10	Taxes - Salcs							
142-0400-4110	Park 1/8 Sales Tax	480,000.00	48,447.03	86,031.21	393,968.79	0.00	393,968.79	82.08
	R10 Sub Totals:	480,000.00	48,447.03	86,031.21	393,968.79	0.00	393,968.79	82.08
R85	Interest Revenue							
142-0400-4850	Interest Revenue	0.00	0.15	0.52	-0.52	0.00	-0.52	0.00
142-0400-4855	Gain on Investment	0.00	0.00	0.00	0.00	0.00	0.00	0.00
	R85 Sub Totals:	0.00	0.15	0.52	-0.52	0.00	-0.52	0.00
	Revenue Sub Totals:	480,000.00	48,447.18	86,031.73	393,968.27	0.00	393,968.27	82.08
E62	Intergovernmental Tsfr							
142-0400-5626	Xfer to Other	480,000.00	48,447.03	86,031.21	393,968.79	0.00	393,968.79	82.08
	E62 Sub Totals:	480,000.00	48,447.03	86,031.21	393,968.79	0.00	393,968.79	82.08
	Expense Sub Totals:	480,000.00	48,447.03	86,031.21	393,968.79	0.00	393,968.79	82.08
	Dept 0400 Sub Totals:	0.00	-0.15	-0.52	0.52	0.00		
	Fund Revenue Sub Totals:	480,000.00	48,447.18	86,031.73	393,968.27	0.00	393,968.27	82.08
	Fund Expense Sub Totals:	480,000.00	48,447.03	86,031.21	393,968.79	0.00	393,968.79	82.08
	Fund 142 Sub Totals:	0.00	-0.15	-0.52	0.52	0.00		

Account Number	Description	Budget Amount	Period Amount	YTD Amount	YTD Var	Encumbered Amount	Available	% Available
Fund 143	Park Bond 2007 DS							
Dept 143-0400	Parks General							
R10	Taxes - Sales							
143-0400-4111	Park Bond Sales Tax	960,000.00	96,894.05	172,062.41	787,937.59	0.00	787,937.59	82.08
	R10 Sub Totals:	960,000.00	96,894.05	172,062.41	787,937.59	0.00	787,937.59	82.08
R62	Intergovernmental Tsfrs							
143-0400-4626	Xfer from Other	0.00	0.00	0.01	-0.01	0.00	-0.01	0.00
	R62 Sub Totals:	0.00	0.00	0.01	-0.01	0.00	-0.01	0.00
R85	Interest Revenue							
143-0400-4850	Interest Revenue	0.00	4.32	8.02	-8.02	0.00	-8.02	0.00
143-0400-4855	Gain on Investment	0.00	0.00	0.00	0.00	0.00	0.00	0.00
	R85 Sub Totals:	0.00	4.32	8.02	-8.02	0.00	-8.02	0.00
	Revenue Sub Totals:	960,000.00	96,898.37	172,070.44	787,929.56	0.00	787,929.56	82.08
E72	Bond Expense							
143-0400-5722	Bond Principal Pmt	955,000.00	0.00	0.00	955,000.00	0.00	955,000.00	100.00
143-0400-5724	Bond Fee	5,000.00	0.00	0.00	5,000.00	0.00	5,000.00	100.00
	E72 Sub Totals:	960,000.00	0.00	0.00	960,000.00	0.00	960,000.00	100.00
E85	Interest Expense							
143-0400-5855	Loss on Investment	0.00	0.00	0.00	0.00	0.00	0.00	0.00
	E85 Sub Totals:	0.00	0.00	0.00	0.00	0.00	0.00	0.00
	Expense Sub Totals:	960,000.00	0.00	0.00	960,000.00	0.00	960,000.00	100.00
	Dept 0400 Sub Totals:	0.00	-96,898.37	-172,070.44	172,070.44	0.00		
	Fund Revenue Sub Totals:	960,000.00	96,898.37	172,070.44	787,929.56	0.00	787,929.56	82.08
	Fund Expense Sub Totals:	960,000.00	0.00	0.00	960,000.00	0.00	960,000.00	100.00
	Fund 143 Sub Totals:	0.00	-96,898.37	-172,070.44	172,070.44	0.00		

Account Number	Description	Budget Amount	Period Amount	YTD Amount	YTD Var	Encumbered Amount	Available	% Available
Fund 145	Park Bond 2010 DS							
Dept 145-0400	Parks General							
R62	Intergovernmental Tsfs							
145-0400-4627	Xfer from Other	360,000.00	29,747.30	60,226.85	299,773.15	0.00	299,773.15	83.27
	R62 Sub Totals:	360,000.00	29,747.30	60,226.85	299,773.15	0.00	299,773.15	83.27
R85	Interest Revenue							
145-0400-4850	Interest Revenue	0.00	8.88	14.58	-14.58	0.00	-14.58	0.00
	R85 Sub Totals:	0.00	8.88	14.58	-14.58	0.00	-14.58	0.00
	Revenue Sub Totals:	360,000.00	29,756.18	60,241.43	299,758.57	0.00	299,758.57	83.27
E72	Bond Expense							
145-0400-5722	Bond Principal Pmt	360,000.00	233,800.00	233,800.00	126,200.00	0.00	126,200.00	35.06
145-0400-5724	Bond Fee	0.00	2,217.50	2,217.50	-2,217.50	0.00	-2,217.50	0.00
	E72 Sub Totals:	360,000.00	236,017.50	236,017.50	123,982.50	0.00	123,982.50	34.44
E85	Interest Expense							
145-0400-5855	Loss on Investment	0.00	0.00	0.00	0.00	0.00	0.00	0.00
	E85 Sub Totals:	0.00	0.00	0.00	0.00	0.00	0.00	0.00
	Expense Sub Totals:	360,000.00	236,017.50	236,017.50	123,982.50	0.00	123,982.50	34.44
	Dept 0400 Sub Totals:	0.00	206,261.32	175,776.07	-175,776.07	0.00		
	Fund Revenue Sub Totals:	360,000.00	29,756.18	60,241.43	299,758.57	0.00	299,758.57	83.27
	Fund Expense Sub Totals:	360,000.00	236,017.50	236,017.50	123,982.50	0.00	123,982.50	34.44
	Fund 145 Sub Totals:	0.00	206,261.32	175,776.07	-175,776.07	0.00		

Account Number	Description	Budget Amount	Period Amount	YTD Amount	YTD Var	Encumbered Amount	Available	% Available
Fund 146	Park Bond 2010 DSR							
Dept 146-0400	Parks General							
R62	Intergovernmental Tsfrs							
146-0400-4627	Xfer from Other	0.00	0.00	0.00	0.00	0.00	0.00	0.00
	R62 Sub Totals:	0.00	0.00	0.00	0.00	0.00	0.00	0.00
R85	Interest Revenue							
146-0400-4850	Interest Revenue	0.00	0.05	0.09	-0.09	0.00	-0.09	0.00
146-0400-4855	Gain on Investment	0.00	0.00	95.72	-95.72	0.00	-95.72	0.00
	R85 Sub Totals:	0.00	0.05	95.81	-95.81	0.00	-95.81	0.00
	Revenue Sub Totals:	0.00	0.05	95.81	-95.81	0.00	-95.81	0.00
E62	Intergovernmental Tsfr							
146-0400-5626	Xfer to Other	0.00	0.00	904.55	-904.55	0.00	-904.55	0.00
	E62 Sub Totals:	0.00	0.00	904.55	-904.55	0.00	-904.55	0.00
E85	Interest Expense							
146-0400-5855	Loss on Investment	0.00	69.21	69.21	-69.21	0.00	-69.21	0.00
	E85 Sub Totals:	0.00	69.21	69.21	-69.21	0.00	-69.21	0.00
	Expense Sub Totals:	0.00	69.21	973.76	-973.76	0.00	-973.76	0.00
	Dept 0400 Sub Totals:	0.00	69.16	877.95	-877.95	0.00		
	Fund Revenue Sub Totals:	0.00	0.05	95.81	-95.81	0.00	-95.81	0.00
	Fund Expense Sub Totals:	0.00	69.21	973.76	-973.76	0.00	-973.76	0.00
	Fund 146 Sub Totals:	0.00	69.16	877.95	-877.95	0.00		

Account Number	Description	Budget Amount	Period Amount	YTD Amount	YTD Var	Encumbered Amount	Available	% Available
Fund 180	Street Bond 2008 Constr							
Dept 180-0800								
R85	Interest Revenue	0.00	2.56	5.30	-5.30	0.00	-5.30	0.00
180-0800-4850	Interest Revenue							
	R85 Sub Totals:	0.00	2.56	5.30	-5.30	0.00	-5.30	0.00
	Revenue Sub Totals:	0.00	2.56	5.30	-5.30	0.00	-5.30	0.00
	Dept 0800 Sub Totals:	0.00	-2.56	-5.30	5.30	0.00		
	Fund Revenue Sub Totals:	0.00	2.56	5.30	-5.30	0.00	-5.30	0.00
	Fund Expense Sub Totals:	0.00	0.00	0.00	0.00	0.00	0.00	0.00
	Fund 180 Sub Totals:	0.00	-2.56	-5.30	5.30	0.00		

Account Number	Description	Budget Amount	Period Amount	YTD Amount	YTD Var	Encumbered Amount	Available	% Available
Fund 181	Street Bond 2008 DSR							
Dept 181-0800								
R85	Interest Revenue	0.00	0.23	0.38	-0.38	0.00	-0.38	0.00
181-0800-4850	Interest Revenue	0.00	0.00	192.27	-192.27	0.00	-192.27	0.00
181-0800-4855	Gain on Investment							
	R85 Sub Totals:	0.00	0.23	192.65	-192.65	0.00	-192.65	0.00
	Revenue Sub Totals:	0.00	0.23	192.65	-192.65	0.00	-192.65	0.00
E62	Intergovernmental Tsfr							
181-0800-5626	Xfer to Other	0.00	0.00	0.00	0.00	0.00	0.00	0.00
	E62 Sub Totals:	0.00	0.00	0.00	0.00	0.00	0.00	0.00
E85	Interest Expense							
181-0800-5855	Loss on Investment	0.00	177.99	177.99	-177.99	0.00	-177.99	0.00
	E85 Sub Totals:	0.00	177.99	177.99	-177.99	0.00	-177.99	0.00
	Expense Sub Totals:	0.00	177.99	177.99	-177.99	0.00	-177.99	0.00
	Dept 0800 Sub Totals:	0.00	177.76	-14.66	14.66	0.00		
	Fund Revenue Sub Totals:	0.00	0.23	192.65	-192.65	0.00	-192.65	0.00
	Fund Expense Sub Totals:	0.00	177.99	177.99	-177.99	0.00	-177.99	0.00
	Fund 181 Sub Totals:	0.00	177.76	-14.66	14.66	0.00		

Account Number	Description	Budget Amount	Period Amount	YTD Amount	YTD Var	Encumbered Amount	Available	% Available
Fund 182	Street Bond 2008 DS							
Dept 182-0800								
R62	Intergovernmental Tsfrs							
182-0800-4623	Xfer from Other Fund	350,000.00	29,298.75	58,597.50	291,402.50	0.00	291,402.50	83.26
	R62 Sub Totals:	350,000.00	29,298.75	58,597.50	291,402.50	0.00	291,402.50	83.26
R85	Interest Revenue							
182-0800-4850	Interest Revenue	0.00	6.41	10.51	-10.51	0.00	-10.51	0.00
182-0800-4855	Gain on Investment	0.00	0.00	0.00	0.00	0.00	0.00	0.00
	R85 Sub Totals:	0.00	6.41	10.51	-10.51	0.00	-10.51	0.00
	Revenue Sub Totals:	350,000.00	29,305.16	58,608.01	291,391.99	0.00	291,391.99	83.25
E72	Bond Expense							
182-0800-5722	Bond Principal Pmt	350,000.00	84,292.50	84,292.50	265,707.50	0.00	265,707.50	75.92
182-0800-5724	Bond Fee	0.00	1,970.00	1,970.00	-1,970.00	0.00	-1,970.00	0.00
	E72 Sub Totals:	350,000.00	86,262.50	86,262.50	263,737.50	0.00	263,737.50	75.35
E85	Interest Expense							
182-0800-5855	Loss on Investment	0.00	0.00	0.00	0.00	0.00	0.00	0.00
	E85 Sub Totals:	0.00	0.00	0.00	0.00	0.00	0.00	0.00
	Expense Sub Totals:	350,000.00	86,262.50	86,262.50	263,737.50	0.00	263,737.50	75.35
	Dept 0800 Sub Totals:	0.00	56,957.34	27,654.49	-27,654.49	0.00		
	Fund Revenue Sub Totals:	350,000.00	29,305.16	58,608.01	291,391.99	0.00	291,391.99	83.25
	Fund Expense Sub Totals:	350,000.00	86,262.50	86,262.50	263,737.50	0.00	263,737.50	75.35
	Fund 182 Sub Totals:	0.00	56,957.34	27,654.49	-27,654.49	0.00		

Account Number	Description	Budget Amount	Period Amount	YTD Amount	YTD Var	Encumbered Amount	Available	% Available
Fund 500	Revenue - Water & WW							
Dept 500-0900	Water Distribution							
R50	Sale of Services							
500-0900-4504	CAW Watershed	45,000.00	3,693.52	7,356.22	37,643.78	0.00	37,643.78	83.65
500-0900-4532	One Time Charge	10,000.00	1,559.00	2,154.00	7,846.00	0.00	7,846.00	78.46
500-0900-4536	Penalties	125,000.00	11,416.59	31,345.13	93,654.87	0.00	93,654.87	74.92
500-0900-4537	Insufficient Check Fee	3,000.00	200.00	375.00	2,625.00	0.00	2,625.00	87.50
500-0900-4540	Sales - CAW System Devel	22,000.00	1,052.75	1,805.50	20,194.50	0.00	20,194.50	91.79
500-0900-4542	Sales - FSDWA	30,000.00	2,265.60	4,513.20	25,486.80	0.00	25,486.80	84.96
500-0900-4544	Water Misc Income	70,000.00	8,836.00	8,561.00	61,439.00	0.00	61,439.00	87.77
500-0900-4548	Sales - Pump Maintenance	1,000.00	106.25	137.50	862.50	0.00	862.50	86.25
500-0900-4550	Sales - Service Charges	20,000.00	1,410.00	3,165.00	16,835.00	0.00	16,835.00	84.18
500-0900-4554	Sales - Water	2,662,000.00	189,203.40	371,666.03	2,290,333.97	0.00	2,290,333.97	86.04
500-0900-4556	Sales - Water Connections	30,000.00	2,525.00	3,750.00	26,250.00	0.00	26,250.00	87.50
500-0900-4560	Sales Tax Revenue	253,000.00	17,863.97	35,175.36	217,824.64	0.00	217,824.64	86.10
500-0900-4562	Swimming Pool Fill	2,000.00	0.00	0.00	2,000.00	0.00	2,000.00	100.00
500-0900-4566	Woodland Hills Watershed	2,000.00	226.35	452.25	1,547.75	0.00	1,547.75	77.39
	R50 Sub Totals:	3,275,000.00	240,358.43	470,456.19	2,804,543.81	0.00	2,804,543.81	85.63
R62	Intergovernmental Tsfrs							
500-0900-4629	Xfer to Water Impact	0.00	6,774.00	9,774.00	-9,774.00	0.00	-9,774.00	0.00
500-0900-4630	Xfer Salem Royalty	1,000.00	90.80	182.40	817.60	0.00	817.60	81.76
	R62 Sub Totals:	1,000.00	6,864.80	9,956.40	-8,956.40	0.00	-8,956.40	0.00
E40	Revenue Sub Totals:	3,276,000.00	247,223.23	480,412.59	2,795,587.41	0.00	2,795,587.41	85.34
	Operations Expense							
500-0900-5475	Credit Card Fees	50,000.00	4,162.62	8,226.95	41,773.05	0.00	41,773.05	83.55
	E40 Sub Totals:	50,000.00	4,162.62	8,226.95	41,773.05	0.00	41,773.05	83.55
E62	Intergovernmental Tsfr							
500-0900-5624	Xfer to Water	4,612,956.35	384,413.02	768,826.04	3,844,130.31	3,844,130.20	0.11	0.00
500-0900-5629	Xfer to Water Impact	60,000.00	3,000.00	4,800.00	55,200.00	0.00	55,200.00	92.00
500-0900-5630	Xfer to Salem Royalty	1,000.00	91.60	186.00	814.00	0.00	814.00	81.40
500-0900-5632	Xfer to Subdivision Impact	0.00	0.00	0.00	0.00	0.00	0.00	0.00
	E62 Sub Totals:	4,673,956.35	387,504.62	773,812.04	3,900,144.31	3,844,130.20	56,014.11	1.20
	Expense Sub Totals:	4,723,956.35	391,667.24	782,038.99	3,941,917.36	3,844,130.20	97,787.16	2.07
Dept 500-0950	Dept 0900 Sub Totals:	1,447,956.35	144,444.01	301,626.40	1,146,329.95	3,844,130.20		
R50	Wastewater Collection							
	Sale of Services							

Account Number	Description	Budget Amount	Period Amount	YTD Amount	YTD Var	Encumbered Amount	Available	% Available
500-0950-4552	Sales - Wastewater	3,779,000.00	294,078.34	579,947.33	3,199,052.67	0.00	3,199,052.67	84.65
500-0950-4558	Sales - WW Connections	13,000.00	450.00	1,050.00	11,950.00	0.00	11,950.00	91.92
R50 Sub Totals:		3,792,000.00	294,528.34	580,997.33	3,211,002.67	0.00	3,211,002.67	84.68
R60	Miscellaneous Revenue							
500-0950-4600	Miscellaneous Revenue	1,000.00	139.75	279.50	720.50	0.00	720.50	72.05
500-0950-4610	Ordinance Number 2013-11	0.00	0.00	0.00	0.00	0.00	0.00	0.00
R60 Sub Totals:		1,000.00	139.75	279.50	720.50	0.00	720.50	72.05
R62	Intergovernmental Tsfrs							
500-0950-4631	Xfer Wastewater Impact	0.00	1,500.00	3,500.00	-3,500.00	0.00	-3,500.00	0.00
R62 Sub Totals:		0.00	1,500.00	3,500.00	-3,500.00	0.00	-3,500.00	0.00
Revenue Sub Totals:		3,793,000.00	296,168.09	584,776.83	3,208,223.17	0.00	3,208,223.17	84.58
E62	Intergovernmental Tsfr							
500-0950-5624	Xfer to Water	4,647,447.18	387,287.26	774,574.52	3,872,872.66	3,872,872.60	0.06	0.00
500-0950-5631	Xfer to Wastewater Impact	44,000.00	2,000.00	4,000.00	40,000.00	0.00	40,000.00	90.91
E62 Sub Totals:		4,691,447.18	389,287.26	778,574.52	3,912,872.66	3,872,872.60	40,000.06	0.85
E72	Bond Expense							
500-0950-5722	Bond Principal Prnt	720,000.00	59,947.08	119,894.16	600,105.84	539,523.72	60,582.12	8.41
E72 Sub Totals:		720,000.00	59,947.08	119,894.16	600,105.84	539,523.72	60,582.12	8.41
Expense Sub Totals:		5,411,447.18	449,234.34	898,468.68	4,512,978.50	4,412,396.32	100,582.18	1.86
Dept 0950 Sub Totals:		1,618,447.18	153,066.25	313,691.85	1,304,755.33	4,412,396.32		
Fund Revenue Sub Totals:		7,069,000.00	543,391.32	1,065,189.42	6,003,810.58	0.00	6,003,810.58	84.93
Fund Expense Sub Totals:		10,135,403.53	840,901.58	1,680,507.67	8,454,895.86	8,256,526.52	198,369.34	1.96
Fund 500 Sub Totals:		3,066,403.53	297,510.26	615,318.25	2,451,085.28	8,256,526.52		

Account Number	Description	Budget Amount	Period Amount	YTD Amount	YTD Var	Encumbered Amount	Available	% Available
Fund 510	Water Operating							
Dept 510-0900								
R62	Intergovernmental Tsfrs							
510-0900-4625	Xfer from Water	4,416,780.35	384,413.02	768,826.04	3,647,954.31	0.00	3,647,954.31	82.59
	R62 Sub Totals:	4,416,780.35	384,413.02	768,826.04	3,647,954.31	0.00	3,647,954.31	82.59
	Revenue Sub Totals:	4,416,780.35	384,413.02	768,826.04	3,647,954.31	0.00	3,647,954.31	82.59
E01	Personnel Expense							
510-0900-5000	Salary Expense	301,208.44	18,796.05	53,657.09	247,551.35	0.00	247,551.35	82.19
510-0900-5005	SWB Reimbursement	109,000.00	9,083.33	9,083.33	99,916.67	9,083.33	90,833.34	83.33
510-0900-5010	Overtime Expense	18,000.00	611.93	1,158.67	16,841.33	0.00	16,841.33	93.56
510-0900-5020	FICA Expense	24,413.49	1,789.48	4,454.65	19,958.84	0.00	19,958.84	81.75
510-0900-5022	Unemployment Expense	3,345.00	0.00	137.77	3,207.23	0.00	3,207.23	95.88
510-0900-5025	Worker's Comp Expense	6,700.00	0.00	6,677.85	22.15	0.00	22.15	0.33
510-0900-5030	APERS Expense	45,667.94	3,371.09	8,445.99	37,221.95	0.00	37,221.95	81.51
510-0900-5040	Health Insurance Expense	95,274.72	5,839.09	12,016.89	83,257.83	0.00	83,257.83	87.39
510-0900-5050	Physical & Drug Screen Exp	1,500.00	0.00	0.00	1,500.00	0.00	1,500.00	100.00
510-0900-5055	Uniform Expense	4,000.00	455.22	455.22	3,544.78	157.83	3,386.95	84.67
510-0900-5060	Travel & Training Expense	6,295.00	1,012.50	1,012.50	5,282.50	0.00	5,282.50	83.92
	E01 Sub Totals:	615,404.59	40,958.69	97,099.96	518,304.63	9,241.16	509,063.47	82.72
E10	Building & Grounds Exp							
510-0900-5102	Repairs & Maint - Building	17,500.00	488.22	488.22	17,011.78	2,337.12	14,674.66	83.86
510-0900-5104	Repairs & Maint - Grounds	3,600.00	0.00	0.00	3,600.00	0.00	3,600.00	100.00
510-0900-5110	Utilities - Electric	46,000.00	4,476.09	8,920.19	37,079.81	0.00	37,079.81	80.61
510-0900-5111	Utilities - Gas	2,500.00	418.38	545.57	1,954.43	0.00	1,954.43	78.18
510-0900-5112	Utilities - Water	500.00	13.46	26.92	473.08	0.00	473.08	94.62
510-0900-5115	Communication Exp - Telephone	11,800.00	714.36	1,298.81	10,501.19	178.44	10,322.75	87.48
510-0900-5120	Insurance - Property	14,500.00	0.00	0.00	14,500.00	0.00	14,500.00	100.00
510-0900-5130	Sanitation	12,000.00	448.38	1,273.43	10,726.57	0.00	10,726.57	89.39
510-0900-5140	Supplies - B&G	1,000.00	0.00	0.00	1,000.00	0.00	1,000.00	100.00
510-0900-5145	Tools	5,000.00	0.00	19.99	4,980.01	0.00	4,980.01	99.60
	E10 Sub Totals:	114,400.00	6,558.89	12,573.13	101,826.87	2,515.56	99,311.31	86.81
E20	Vehicle Expense							
510-0900-5200	Fuel Expense	30,000.00	980.33	2,583.82	27,416.18	0.00	27,416.18	91.39
510-0900-5210	Service & Repair - Vehicle	10,000.00	914.74	926.74	9,073.26	319.95	8,753.31	87.53
510-0900-5218	Tire Expense	1,500.00	0.00	0.00	1,500.00	0.00	1,500.00	100.00
510-0900-5225	Insurance Expense - Vehicle	6,000.00	0.00	4,113.97	1,886.03	0.00	1,886.03	31.43
510-0900-5240	Equipment Rental	1,000.00	0.00	0.00	1,000.00	0.00	1,000.00	100.00
	E20 Sub Totals:	48,500.00	1,895.07	7,624.53	40,875.47	319.95	40,555.52	83.62
E30	Supply Expense							

Account Number	Description	Budget Amount	Period Amount	YTD Amount	YTD Var	Encumbered Amount	Available	% Available
510-0900-5300	Supplies - Office	3,000.00	1,014.32	1,014.32	1,985.68	91.53	1,894.15	63.14
510-0900-5322	Supplies - Operating	75,000.00	829.72	1,660.05	73,339.95	9,675.08	63,664.87	84.89
510-0900-5324	Supplies - Chemicals	3,000.00	0.00	0.00	3,000.00	0.00	3,000.00	100.00
510-0900-5326	Supplies - Lab	500.00	0.00	0.00	500.00	0.00	500.00	100.00
510-0900-5350	Postage Expense	25,000.00	1,613.58	3,022.15	21,977.85	0.00	21,977.85	87.91
510-0900-5360	Cost of Water	1,015,000.00	71,348.80	141,223.06	873,776.94	0.00	873,776.94	86.09
	E30 Sub Totals:	1,121,500.00	74,806.42	146,919.58	974,580.42	9,766.61	964,813.81	86.03
E40	Operations Expense							
510-0900-5142	Janitorial Supplies	3,000.00	148.12	318.42	2,681.58	170.30	2,511.28	83.71
510-0900-5301	Office Equipment	2,000.00	0.00	0.00	2,000.00	0.00	2,000.00	100.00
510-0900-5475	Credit Card Processing Fee	17,500.00	1,113.38	2,180.26	15,319.74	0.00	15,319.74	87.54
510-0900-5480	Dues & Subscriptions	8,500.00	177.60	1,930.20	6,569.80	0.00	6,569.80	77.29
510-0900-5515	Permit Fee Expense	36,000.00	0.00	0.00	36,000.00	0.00	36,000.00	100.00
510-0900-5530	Safety Program	1,000.00	0.00	0.00	1,000.00	149.50	850.50	85.05
510-0900-5535	Sales Tax Expense	260,000.00	10,029.64	28,056.64	231,943.36	0.00	231,943.36	89.21
	E40 Sub Totals:	328,000.00	11,468.74	32,485.52	295,514.48	319.80	295,194.68	90.00
E55	Professional Services							
510-0900-5550	Prof Services - Acctg & Audit	10,000.00	0.00	0.00	10,000.00	0.00	10,000.00	100.00
510-0900-5553	Prof Services - Advertising	8,000.00	0.00	0.00	8,000.00	415.63	7,584.37	94.80
510-0900-5571	Prof Services - Engineering	9,180.00	765.00	1,898.22	7,281.78	0.00	7,281.78	79.32
510-0900-5574	Prof Services - GIS	6,120.00	0.00	0.00	6,120.00	0.00	6,120.00	100.00
510-0900-5586	Prof Services - Other	10,000.00	2,770.10	3,993.89	6,006.11	1,225.00	4,781.11	47.81
510-0900-5589	Prof Services - Printing	2,000.00	390.71	390.71	1,609.29	0.00	1,609.29	80.46
	E55 Sub Totals:	45,300.00	3,925.81	6,282.82	39,017.18	1,640.63	37,376.55	82.51
E60	Miscellaneous Expense							
510-0900-5600	Miscellaneous Expense	0.00	0.00	249.63	-249.63	0.00	-249.63	0.00
510-0900-5606	Computer Hardware	5,000.00	0.00	0.00	5,000.00	0.00	5,000.00	100.00
510-0900-5608	Computer Software Support	23,400.00	0.00	0.00	23,400.00	0.00	23,400.00	100.00
510-0900-5610	Website Expense	1,000.00	0.00	0.00	1,000.00	0.00	1,000.00	100.00
510-0900-5614	Copier Maint & Lease	4,000.00	0.00	1,048.20	2,951.80	1,721.49	1,230.31	30.76
	E60 Sub Totals:	33,400.00	0.00	1,297.83	32,102.17	1,721.49	30,380.68	90.96
E62	Intergovernmental Tsr							
510-0900-5626	Xfer Depreciation Fd - Water	90,000.00	6,202.95	12,130.02	77,869.98	0.00	77,869.98	86.52
	E62 Sub Totals:	90,000.00	6,202.95	12,130.02	77,869.98	0.00	77,869.98	86.52
E72	Bond Expense							
510-0900-5722	Bond Principal Prnt	713,176.00	20,364.49	81,457.96	631,718.04	55,494.59	576,223.45	80.80
	E72 Sub Totals:	713,176.00	20,364.49	81,457.96	631,718.04	55,494.59	576,223.45	80.80

Account Number	Description	Budget Amount	Period Amount	YTD Amount	YTD Var	Encumbered Amount	Available	% Available
E80	Fixed Assets							
510-0900-5810	Fixed Assets - Equipment	0.00	0.00	0.00	0.00	0.00	0.00	0.00
510-0900-5816	Fixed Assets - Infrastructure	300,000.00	0.00	0.00	300,000.00	0.00	300,000.00	100.00
510-0900-5818	Meters / Boxes	23,000.00	1,053.94	1,053.94	21,946.06	0.00	21,946.06	95.42
510-0900-5819	AMI Meter Reading Expense	15,000.00	0.00	0.00	15,000.00	0.00	15,000.00	100.00
510-0900-5821	Other Equipment	335,000.00	0.00	0.00	335,000.00	0.00	335,000.00	100.00
510-0900-5822	COE Degray Project	90,000.00	0.00	0.00	90,000.00	0.00	90,000.00	100.00
510-0900-5823	COE Degray O&M	30,000.00	0.00	0.00	30,000.00	0.00	30,000.00	100.00
510-0900-5828	Project - Snooks Ln Extension	285,000.00	9,800.00	9,962.00	275,038.00	0.00	275,038.00	96.50
E80 Sub Totals:		1,078,000.00	10,853.94	11,015.94	1,066,984.06	0.00	1,066,984.06	98.98
E85	Interest Expense							
510-0900-5850	Interest Expense	432,572.00	14,765.59	59,062.36	373,509.64	14,765.59	358,744.05	82.93
E85 Sub Totals:		432,572.00	14,765.59	59,062.36	373,509.64	14,765.59	358,744.05	82.93
Expense Sub Totals:		4,620,252.59	191,800.59	467,949.65	4,152,302.94	95,785.38	4,056,517.56	87.80
Dept 0900 Sub Totals:		203,472.24	-192,612.43	-300,876.39	504,348.63	95,785.38		
Intergovernmental Tsfrs								
510-0950-4625	Xfer from Sewer Sales	4,647,447.18	387,287.26	774,574.52	3,872,872.66	0.00	3,872,872.66	83.33
R62 Sub Totals:		4,647,447.18	387,287.26	774,574.52	3,872,872.66	0.00	3,872,872.66	83.33
Revenue Sub Totals:		4,647,447.18	387,287.26	774,574.52	3,872,872.66	0.00	3,872,872.66	83.33
E01	Personnel Expense							
510-0950-5000	Salary Expense	463,959.72	35,777.01	89,433.15	374,526.57	0.00	374,526.57	80.72
510-0950-5005	SWB Reimbursement	109,000.00	9,083.33	9,083.33	99,916.67	9,083.33	90,833.34	83.33
510-0950-5010	Overtime Expense	50,000.00	2,248.36	6,694.19	43,305.81	0.00	43,305.81	86.61
510-0950-5020	FICA Expense	39,317.91	2,846.27	7,220.42	32,097.49	0.00	32,097.49	81.64
510-0950-5022	Unemployment Expense	5,505.00	0.00	180.33	5,324.67	0.00	5,324.67	96.72
510-0950-5025	Worker's Comp Expense	5,500.00	0.00	5,300.56	199.44	0.00	199.44	3.63
510-0950-5030	APERS Expense	76,477.17	5,612.50	14,188.39	62,288.78	0.00	62,288.78	81.45
510-0950-5040	Health Insurance Expense	90,798.72	9,235.83	18,130.66	72,668.06	0.00	72,668.06	80.03
510-0950-5050	Physical & Drug Screen Exp	2,000.00	0.00	0.00	2,000.00	0.00	2,000.00	100.00
510-0950-5055	Uniform Expense	4,000.00	236.15	292.94	3,707.06	0.00	3,707.06	92.68
510-0950-5060	Travel & Training Expense	6,295.00	1,012.50	1,012.50	5,282.50	40.94	5,241.56	83.27
E01 Sub Totals:		852,853.52	66,051.95	151,536.47	701,317.05	9,124.27	692,192.78	81.16
E10	Building & Grounds Exp							
510-0950-5102	Repairs & Maint - Building	17,600.00	1,026.11	2,150.68	15,449.32	2,324.84	13,124.48	74.57
510-0950-5110	Utilities - Electric	250,000.00	21,995.80	42,750.02	207,249.98	0.00	207,249.98	82.90

Account Number	Description	Budget Amount	Period Amount	YTD Amount	YTD Var	Encumbered Amount	Available	% Available
510-0950-5111	Utilities - Gas	3,000.00	379.91	470.13	2,529.87	0.00	2,529.87	84.33
510-0950-5112	Utilities - Water	1,000.00	13.46	26.92	973.08	0.00	973.08	97.31
510-0950-5115	Communication Exp - Telephone	12,500.00	588.73	1,065.52	11,434.48	178.43	11,256.05	90.05
510-0950-5120	Insurance - Property	15,000.00	0.00	0.00	15,000.00	0.00	15,000.00	100.00
510-0950-5130	Sanitation	12,000.00	448.38	1,273.43	10,726.57	0.00	10,726.57	89.39
510-0950-5140	Supplies - B&G	1,500.00	0.00	0.00	1,500.00	0.00	1,500.00	100.00
510-0950-5145	Tools	5,500.00	0.00	19.98	5,480.02	0.00	5,480.02	99.64
E10 Sub Totals:		318,100.00	24,452.39	47,756.68	270,343.32	2,503.27	267,840.05	84.20
E20	Vehicle Expense							
510-0950-5200	Fuel Expense	40,000.00	1,200.93	2,645.48	37,354.52	0.00	37,354.52	93.39
510-0950-5210	Service & Repair - Vehicle	40,000.00	2,624.11	2,624.11	37,375.89	1,754.84	35,621.05	89.05
510-0950-5218	Tire Expense	8,000.00	0.00	0.00	8,000.00	407.23	7,592.77	94.91
510-0950-5225	Insurance Expense - Vehicle	7,500.00	0.00	6,139.34	1,360.66	0.00	1,360.66	18.14
510-0950-5240	Equipment Rental	3,000.00	0.00	0.00	3,000.00	0.00	3,000.00	100.00
E20 Sub Totals:		98,500.00	3,825.04	11,408.93	87,091.07	2,162.07	84,929.00	86.22
E30	Supply Expense							
510-0950-5223	Maintenance - Office Equipment	1,000.00	0.00	0.00	1,000.00	0.00	1,000.00	100.00
510-0950-5300	Supplies - Office	5,000.00	1,091.67	1,091.67	3,908.33	226.67	3,681.66	73.63
510-0950-5322	Supplies - Operating	156,000.00	4,938.42	4,009.95	151,990.05	1,347.89	150,642.16	96.57
510-0950-5324	Supplies - Chemicals	76,000.00	7,720.32	7,900.32	68,099.68	2,094.29	66,005.39	86.85
510-0950-5326	Supplies - Lab	35,000.00	0.00	0.00	35,000.00	0.00	35,000.00	100.00
510-0950-5350	Postage Expense	25,000.00	1,613.57	3,022.15	21,977.85	0.00	21,977.85	87.91
E30 Sub Totals:		298,000.00	15,363.98	16,024.09	281,975.91	3,668.85	278,307.06	93.39
E40	Operations Expense							
510-0950-5142	Janitorial Supplies	1,800.00	148.10	362.76	1,437.24	125.92	1,311.32	72.85
510-0950-5475	Credit Card Processing Fee	17,500.00	1,113.37	2,180.24	15,319.76	0.00	15,319.76	87.54
510-0950-5480	Dues & Subscriptions	18,000.00	1,290.60	14,385.20	3,614.80	0.00	3,614.80	20.08
510-0950-5530	Safety Program	1,000.00	0.00	0.00	1,000.00	0.00	1,000.00	100.00
510-0950-5540	Equip Purchase - I & I	5,000.00	0.00	0.00	5,000.00	0.00	5,000.00	100.00
510-0950-5541	Outside Contractors- I & I	50,000.00	0.00	0.00	50,000.00	0.00	50,000.00	100.00
510-0950-5542	Service & Repair - I & I	12,000.00	0.00	0.00	12,000.00	275.94	11,724.06	97.70
E40 Sub Totals:		105,300.00	2,552.07	16,928.20	88,371.80	401.86	87,969.94	83.54
E55	Professional Services							
510-0950-5550	Prof Services - Acctg & Audit	10,000.00	0.00	0.00	10,000.00	0.00	10,000.00	100.00
510-0950-5553	Prof Services - Advertising	8,500.00	0.00	0.00	8,500.00	0.00	8,500.00	100.00
510-0950-5571	Prof Services - Engineering	9,180.00	765.00	1,898.22	7,281.78	0.00	7,281.78	79.32
510-0950-5574	Prof Services - GIS	6,120.00	0.00	0.00	6,120.00	0.00	6,120.00	100.00
510-0950-5586	Prof Services - Other	20,000.00	2,496.20	2,535.20	17,464.80	0.00	17,464.80	87.32
510-0950-5589	Prof Services - Printing	2,000.00	320.00	320.00	1,680.00	0.00	1,680.00	84.00

Account Number	Description	Budget Amount	Period Amount	YTD Amount	YTD Var	Encumbered Amount	Available	% Available
E55 Sub Totals:		55,800.00	3,581.20	4,753.42	51,046.58	0.00	51,046.58	91.48
E60	Miscellaneous Expense							
510-0950-5606	Computer Maint & Support	42,300.00	0.00	2,940.00	39,360.00	0.00	39,360.00	93.05
510-0950-5608	Computer Software	49,800.00	0.00	0.00	49,800.00	0.00	49,800.00	100.00
510-0950-5614	Copier Maint & Lease	5,000.00	0.00	1,088.20	3,911.80	2,041.77	1,870.03	37.40
E60 Sub Totals:		97,100.00	0.00	4,028.20	93,071.80	2,041.77	91,030.03	93.75
E62	Intergovernmental Tsfr							
510-0950-5626	Xfer to Other	109,000.00	8,598.26	16,932.20	92,067.80	0.00	92,067.80	84.47
E62 Sub Totals:		109,000.00	8,598.26	16,932.20	92,067.80	0.00	92,067.80	84.47
E72	Bond Expense							
510-0950-5722	Bond Principal Pmt	317,242.00	0.00	0.00	317,242.00	0.00	317,242.00	100.00
E72 Sub Totals:		317,242.00	0.00	0.00	317,242.00	0.00	317,242.00	100.00
E80	Fixed Assets							
510-0950-5808	Fixed Assets - Vehicles	28,000.00	0.00	0.00	28,000.00	27,927.00	73.00	0.26
510-0950-5810	Fixed Assets - Equipment	55,000.00	0.00	0.00	55,000.00	10,467.51	44,532.49	80.97
510-0950-5816	Fixed Assets - Infrastructure	300,000.00	0.00	0.00	300,000.00	0.00	300,000.00	100.00
510-0950-5818	Meters / Boxes	23,000.00	1,053.94	1,053.94	21,946.06	0.00	21,946.06	95.42
510-0950-5819	Project - Dewatering Facility	1,432,758.00	0.00	0.00	1,432,758.00	0.00	1,432,758.00	100.00
E80 Sub Totals:		1,838,758.00	1,053.94	1,053.94	1,837,704.06	38,394.51	1,799,309.55	97.85
E85	Interest Expense							
510-0950-5850	Interest Expense	565,742.00	0.00	0.00	565,742.00	0.00	565,742.00	100.00
E85 Sub Totals:		565,742.00	0.00	0.00	565,742.00	0.00	565,742.00	100.00
Expense Sub Totals:		4,656,395.52	125,478.83	270,422.13	4,385,973.39	58,296.60	4,327,676.79	92.94
Dept 0950 Sub Totals:		8,948.34	-261,808.43	-504,152.39	513,100.73	58,296.60		
Dept 510-0970								
E01	Personnel Expense							
510-0970-5000	Salary Expense	0.00	0.00	0.00	0.00	0.00	0.00	0.00
510-0970-5010	Overtime Expense	0.00	0.00	0.00	0.00	0.00	0.00	0.00
510-0970-5020	FICA Expense	0.00	0.00	0.00	0.00	0.00	0.00	0.00
510-0970-5030	APERS Expense	0.00	0.00	0.00	0.00	0.00	0.00	0.00
510-0970-5040	Health Insurance Expense	0.00	0.00	0.00	0.00	0.00	0.00	0.00
E01 Sub Totals:		0.00	0.00	0.00	0.00	0.00	0.00	0.00

Account Number	Description	Budget Amount	Period Amount	YTD Amount	YTD Var	Encumbered Amount	Available	% Available
	Expense Sub Totals:	0.00	0.00	0.00	0.00	0.00	0.00	0.00
	Dept 0970 Sub Totals:	0.00	0.00	0.00	0.00	0.00		
	Fund Revenue Sub Totals:	9,064,227.53	771,700.28	1,543,400.56	7,520,826.97	0.00	7,520,826.97	82.97
	Fund Expense Sub Totals:	9,276,648.11	317,279.42	738,371.78	8,538,276.33	154,081.98	8,384,194.35	90.38
	Fund 510 Sub Totals:	212,420.58	-454,420.86	-805,028.78	1,017,449.36	154,081.98		

Account Number	Description	Budget Amount	Period Amount	YTD Amount	YTD Var	Encumbered Amount	Available	% Available
Fund 520	Depreciation - Water							
Dept 520-0900	Intergovernmental Tsfrs							
R62	Xfer from Water	90,000.00	0.00	0.00	90,000.00	0.00	90,000.00	100.00
520-0900-4625	R62 Sub Totals:	90,000.00	0.00	0.00	90,000.00	0.00	90,000.00	100.00
R85	Interest Revenue							
520-0900-4850	Interest Revenue	0.00	0.00	0.00	0.00	0.00	0.00	0.00
	R85 Sub Totals:	0.00	0.00	0.00	0.00	0.00	0.00	0.00
	Revenue Sub Totals:	90,000.00	0.00	0.00	90,000.00	0.00	90,000.00	100.00
E62	Intergovernmental Tsfr							
520-0900-5624	Xfer to Water	0.00	0.00	0.00	0.00	0.00	0.00	0.00
	E62 Sub Totals:	0.00	0.00	0.00	0.00	0.00	0.00	0.00
	Expense Sub Totals:	0.00	0.00	0.00	0.00	0.00	0.00	0.00
	Dept 0900 Sub Totals:	-90,000.00	0.00	0.00	-90,000.00	0.00		
	Fund Revenue Sub Totals:	90,000.00	0.00	0.00	90,000.00	0.00	90,000.00	100.00
	Fund Expense Sub Totals:	0.00	0.00	0.00	0.00	0.00	0.00	0.00
	Fund 520 Sub Totals:	-90,000.00	0.00	0.00	-90,000.00	0.00		

Account Number	Description	Budget Amount	Period Amount	YTD Amount	YTD Var	Encumbered Amount	Available	% Available
Fund 525	Depreciation - WW							
Dept 525-0950	Intergovernmental Tsfrs							
R62	Xfer from Water	109,000.00	14,801.21	29,062.22	79,937.78	0.00	79,937.78	73.34
525-0950-4625	R62 Sub Totals:	109,000.00	14,801.21	29,062.22	79,937.78	0.00	79,937.78	73.34
R85	Interest Revenue	0.00	24.94	50.73	-50.73	0.00	-50.73	0.00
525-0950-4850	Interest Revenue	0.00	24.94	50.73	-50.73	0.00	-50.73	0.00
	R85 Sub Totals:	0.00	24.94	50.73	-50.73	0.00	-50.73	0.00
	Revenue Sub Totals:	109,000.00	14,826.15	29,112.95	79,887.05	0.00	79,887.05	73.29
E62	Intergovernmental Tsfr							
525-0950-5624	Xfer to Water	0.00	0.00	0.00	0.00	0.00	0.00	0.00
	E62 Sub Totals:	0.00	0.00	0.00	0.00	0.00	0.00	0.00
	Expense Sub Totals:	0.00	0.00	0.00	0.00	0.00	0.00	0.00
	Dept 0950 Sub Totals:	-109,000.00	-14,826.15	-29,112.95	-79,887.05	0.00		
	Fund Revenue Sub Totals:	109,000.00	14,826.15	29,112.95	79,887.05	0.00	79,887.05	73.29
	Fund Expense Sub Totals:	0.00	0.00	0.00	0.00	0.00	0.00	0.00
	Fund 525 Sub Totals:	-109,000.00	-14,826.15	-29,112.95	-79,887.05	0.00		

Account Number	Description	Budget Amount	Period Amount	YTD Amount	YTD Var	Encumbered Amount	Available	% Available
Fund 530	Sub-Div Impact Water							
Dept 530-0900	Intergovernmental Tsfrs							
R62	Xfer from Water	0.00	0.00	0.00	0.00	0.00	0.00	0.00
530-0900-4625	R62 Sub Totals:	0.00	0.00	0.00	0.00	0.00	0.00	0.00
R85	Interest Revenue	0.00	0.00	0.00	0.00	0.00	0.00	0.00
530-0900-4850	Interest Revenue	0.00	0.00	0.00	0.00	0.00	0.00	0.00
	R85 Sub Totals:	0.00	0.00	0.00	0.00	0.00	0.00	0.00
	Revenue Sub Totals:	0.00	0.00	0.00	0.00	0.00	0.00	0.00
E62	Intergovernmental Tsfr							
530-0900-5624	Xfer to Water	0.00	0.00	0.00	0.00	0.00	0.00	0.00
	E62 Sub Totals:	0.00	0.00	0.00	0.00	0.00	0.00	0.00
	Expense Sub Totals:	0.00	0.00	0.00	0.00	0.00	0.00	0.00
	Dept 0900 Sub Totals:	0.00	0.00	0.00	0.00	0.00	0.00	0.00
	Fund Revenue Sub Totals:	0.00	0.00	0.00	0.00	0.00	0.00	0.00
	Fund Expense Sub Totals:	0.00	0.00	0.00	0.00	0.00	0.00	0.00
	Fund 530 Sub Totals:	0.00	0.00	0.00	0.00	0.00	0.00	0.00

Account Number	Description	Budget Amount	Period Amount	YTD Amount	YTD Var	Encumbered Amount	Available	% Available
Fund 535	Sub-Div Impact WW							
Dept 535-0950	Intergovernmental Tsfrs							
R62	Xfer from Water	0.00	0.00	0.00	0.00	0.00	0.00	0.00
535-0950-4625	R62 Sub Totals:	0.00	0.00	0.00	0.00	0.00	0.00	0.00
R85	Interest Revenue	0.00	0.00	0.00	0.00	0.00	0.00	0.00
535-0950-4850	Interest Revenue	0.00	0.00	0.00	0.00	0.00	0.00	0.00
	R85 Sub Totals:	0.00	0.00	0.00	0.00	0.00	0.00	0.00
	Revenue Sub Totals:	0.00	0.00	0.00	0.00	0.00	0.00	0.00
E62	Intergovernmental Tsfr							
535-0950-5624	Xfer to Water	0.00	0.00	0.00	0.00	0.00	0.00	0.00
	E62 Sub Totals:	0.00	0.00	0.00	0.00	0.00	0.00	0.00
	Expense Sub Totals:	0.00	0.00	0.00	0.00	0.00	0.00	0.00
	Dept 0950 Sub Totals:	0.00	0.00	0.00	0.00	0.00	0.00	0.00
	Fund Revenue Sub Totals:	0.00	0.00	0.00	0.00	0.00	0.00	0.00
	Fund Expense Sub Totals:	0.00	0.00	0.00	0.00	0.00	0.00	0.00
	Fund 535 Sub Totals:	0.00	0.00	0.00	0.00	0.00	0.00	0.00

Account Number	Description	Budget Amount	Period Amount	YTD Amount	YTD Var	Encumbered Amount	Available	% Available
Fund 540	Fair Share							
Dept 540-0900	Intergovernmental Tsfrs							
R62	Xfer from Water	0.00	0.00	0.00	0.00	0.00	0.00	0.00
540-0900-4625	R62 Sub Totals:	0.00	0.00	0.00	0.00	0.00	0.00	0.00
R85	Interest Revenue	0.00	0.00	0.00	0.00	0.00	0.00	0.00
540-0900-4850	Interest Revenue	0.00	0.00	0.00	0.00	0.00	0.00	0.00
	R85 Sub Totals:	0.00	0.00	0.00	0.00	0.00	0.00	0.00
	Revenue Sub Totals:	0.00	0.00	0.00	0.00	0.00	0.00	0.00
E62	Intergovernmental Tsfr							
540-0900-5624	Xfer to Water	0.00	0.00	0.00	0.00	0.00	0.00	0.00
	E62 Sub Totals:	0.00	0.00	0.00	0.00	0.00	0.00	0.00
	Expense Sub Totals:	0.00	0.00	0.00	0.00	0.00	0.00	0.00
	Dept 0900 Sub Totals:	0.00	0.00	0.00	0.00	0.00	0.00	0.00
	Fund Revenue Sub Totals:	0.00	0.00	0.00	0.00	0.00	0.00	0.00
	Fund Expense Sub Totals:	0.00	0.00	0.00	0.00	0.00	0.00	0.00
	Fund 540 Sub Totals:	0.00	0.00	0.00	0.00	0.00	0.00	0.00

Account Number	Description	Budget Amount	Period Amount	YTD Amount	YTD Var	Encumbered Amount	Available	% Available
Fund 550	Impact - Water							
Dept 550-0900	Intergovernmental Tsfrs							
R62	Xfer from Water	60,000.00	3,000.00	4,800.00	55,200.00	0.00	55,200.00	92.00
550-0900-4625	R62 Sub Totals:	60,000.00	3,000.00	4,800.00	55,200.00	0.00	55,200.00	92.00
R85	Interest Revenue	0.00	4.26	8.68	-8.68	0.00	-8.68	0.00
550-0900-4850	Interest Revenue	0.00	4.26	8.68	-8.68	0.00	-8.68	0.00
	R85 Sub Totals:	0.00	4.26	8.68	-8.68	0.00	-8.68	0.00
	Revenue Sub Totals:	60,000.00	3,004.26	4,808.68	55,191.32	0.00	55,191.32	91.99
E62	Intergovernmental Tsfr							
550-0900-5624	Xfer to Water	0.00	0.00	0.00	0.00	0.00	0.00	0.00
	E62 Sub Totals:	0.00	0.00	0.00	0.00	0.00	0.00	0.00
	Expense Sub Totals:	0.00	0.00	0.00	0.00	0.00	0.00	0.00
	Dept 0900 Sub Totals:	-60,000.00	-3,004.26	-4,808.68	-55,191.32	0.00		
	Fund Revenue Sub Totals:	60,000.00	3,004.26	4,808.68	55,191.32	0.00	55,191.32	91.99
	Fund Expense Sub Totals:	0.00	0.00	0.00	0.00	0.00	0.00	0.00
	Fund 550 Sub Totals:	-60,000.00	-3,004.26	-4,808.68	-55,191.32	0.00		

Account Number	Description	Budget Amount	Period Amount	YTD Amount	YTD Var	Encumbered Amount	Available	% Available
Fund 555	Impact - WW							
Dept 555-0950	Intergovernmental Tsfrs							
R62	Xfer from Water	44,000.00	-40,250.00	-38,250.00	82,250.00	0.00	82,250.00	186.93
555-0950-4625	R62 Sub Totals:	44,000.00	-40,250.00	-38,250.00	82,250.00	0.00	82,250.00	186.93
R85	Interest Revenue	0.00	5.33	10.91	-10.91	0.00	-10.91	0.00
555-0950-4850	Interest Revenue	0.00	5.33	10.91	-10.91	0.00	-10.91	0.00
	R85 Sub Totals:							
	Revenue Sub Totals:	44,000.00	-40,244.67	-38,239.09	82,239.09	0.00	82,239.09	186.91
E62	Intergovernmental Tsfr							
555-0950-5624	Xfer to Water	0.00	0.00	0.00	0.00	0.00	0.00	0.00
	E62 Sub Totals:	0.00	0.00	0.00	0.00	0.00	0.00	0.00
	Expense Sub Totals:	0.00	0.00	0.00	0.00	0.00	0.00	0.00
	Dept 0950 Sub Totals:	-44,000.00	40,244.67	38,239.09	-82,239.09	0.00		
	Fund Revenue Sub Totals:	44,000.00	-40,244.67	-38,239.09	82,239.09	0.00	82,239.09	186.91
	Fund Expense Sub Totals:	0.00	0.00	0.00	0.00	0.00	0.00	0.00
	Fund 555 Sub Totals:	-44,000.00	40,244.67	38,239.09	-82,239.09	0.00		

Account Number	Description	Budget Amount	Period Amount	YTD Amount	YTD Var	Encumbered Amount	Available	% Available
Fund 560	Salem Royalty							
Dept 560-0900	Intergovernmental Tsfrs							
R62	Xfer from Water	1,000.00	91.60	186.00	814.00	0.00	814.00	81.40
560-0900-4625	R62 Sub Totals:	1,000.00	91.60	186.00	814.00	0.00	814.00	81.40
R85	Interest Revenue	0.00	1.69	3.50	-3.50	0.00	-3.50	0.00
560-0900-4850	Interest Revenue	0.00	1.69	3.50	-3.50	0.00	-3.50	0.00
	R85 Sub Totals:	0.00	1.69	3.50	-3.50	0.00	-3.50	0.00
E60	Revenue Sub Totals:	1,000.00	93.29	189.50	810.50	0.00	810.50	81.05
560-0900-5602	Miscellaneous Expense							
	Royalty Payment	1,000.00	175.80	175.80	824.20	0.00	824.20	82.42
	E60 Sub Totals:	1,000.00	175.80	175.80	824.20	0.00	824.20	82.42
	Expense Sub Totals:	1,000.00	175.80	175.80	824.20	0.00	824.20	82.42
	Dept 0900 Sub Totals:	0.00	82.51	-13.70	13.70	0.00		
	Fund Revenue Sub Totals:	1,000.00	93.29	189.50	810.50	0.00	810.50	81.05
	Fund Expense Sub Totals:	1,000.00	175.80	175.80	824.20	0.00	824.20	82.42
	Fund 560 Sub Totals:	0.00	82.51	-13.70	13.70	0.00		

Account Number	Description	Budget Amount	Period Amount	YTD Amount	YTD Var	Encumbered Amount	Available	% Available
Fund 600	W/WW Bond 2008A DS							
Dept 600-0900								
R62	Intergovernmental Tsfrs							
600-0900-4625	Xfer from Water	720,000.00	59,947.08	119,894.34	600,105.66	0.00	600,105.66	83.35
	R62 Sub Totals:	720,000.00	59,947.08	119,894.34	600,105.66	0.00	600,105.66	83.35
R85	Interest Revenue							
600-0900-4850	Interest Revenue	0.00	3.25	5.16	-5.16	0.00	-5.16	0.00
	R85 Sub Totals:	0.00	3.25	5.16	-5.16	0.00	-5.16	0.00
	Revenue Sub Totals:	720,000.00	59,950.33	119,899.50	600,100.50	0.00	600,100.50	83.35
E72	Bond Expense							
600-0900-5722	Bond Principal Pmt	405,000.00	0.00	0.00	405,000.00	0.00	405,000.00	100.00
600-0900-5724	Bond Fee	0.00	0.00	0.00	0.00	0.00	0.00	0.00
	E72 Sub Totals:	405,000.00	0.00	0.00	405,000.00	0.00	405,000.00	100.00
E85	Interest Expense							
600-0900-5850	Interest Expense	315,000.00	0.00	0.00	315,000.00	0.00	315,000.00	100.00
	E85 Sub Totals:	315,000.00	0.00	0.00	315,000.00	0.00	315,000.00	100.00
	Expense Sub Totals:	720,000.00	0.00	0.00	720,000.00	0.00	720,000.00	100.00
	Dept 0900 Sub Totals:	0.00	-59,950.33	-119,899.50	119,899.50	0.00		
	Fund Revenue Sub Totals:	720,000.00	59,950.33	119,899.50	600,100.50	0.00	600,100.50	83.35
	Fund Expense Sub Totals:	720,000.00	0.00	0.00	720,000.00	0.00	720,000.00	100.00
	Fund 600 Sub Totals:	0.00	-59,950.33	-119,899.50	119,899.50	0.00		

Account Number	Description	Budget Amount	Period Amount	YTD Amount	YTD Var	Encumbered Amount	Available	% Available
Fund 601	W/W/W Bond 2008A DSR							
Dept 601-0900	Intergovernmental Tsfris							
R62	Xfer from Other	0.00	0.00	0.00	0.00	0.00	0.00	0.00
601-0900-4627	R62 Sub Totals:	0.00	0.00	0.00	0.00	0.00	0.00	0.00
R85	Interest Revenue							
601-0900-4850	Interest Revenue	0.00	0.13	0.21	-0.21	0.00	-0.21	0.00
601-0900-4855	Gain on Investment	0.00	0.00	361.31	-361.31	0.00	-361.31	0.00
	R85 Sub Totals:	0.00	0.13	361.52	-361.52	0.00	-361.52	0.00
	Revenue Sub Totals:	0.00	0.13	361.52	-361.52	0.00	-361.52	0.00
E62	Intergovernmental Tsfr							
601-0900-5626	Xfer to Other	0.00	0.00	0.08	-0.08	0.00	-0.08	0.00
	E62 Sub Totals:	0.00	0.00	0.08	-0.08	0.00	-0.08	0.00
E85	Interest Expense							
601-0900-5855	Loss on Investment	0.00	380.10	380.10	-380.10	0.00	-380.10	0.00
	E85 Sub Totals:	0.00	380.10	380.10	-380.10	0.00	-380.10	0.00
	Expense Sub Totals:	0.00	380.10	380.18	-380.18	0.00	-380.18	0.00
	Dept 0900 Sub Totals:	0.00	379.97	18.66	-18.66	0.00		
	Fund Revenue Sub Totals:	0.00	0.13	361.52	-361.52	0.00	-361.52	0.00
	Fund Expense Sub Totals:	0.00	380.10	380.18	-380.18	0.00	-380.18	0.00
	Fund 601 Sub Totals:	0.00	379.97	18.66	-18.66	0.00		

Account Number	Description	Budget Amount	Period Amount	YTD Amount	YTD Var	Encumbered Amount	Available	% Available
Fund 605	W/WW Bond 2008B DSR							
Dept 605-0900	Intergovernmental Tsfrs							
R62	Xfer from Other	0.00	0.00	0.00	0.00	0.00	0.00	0.00
605-0900-4627	R62 Sub Totals:	0.00	0.00	0.00	0.00	0.00	0.00	0.00
R85	Interest Revenue							
605-0900-4850	Interest Revenue	0.00	0.16	0.26	-0.26	0.00	-0.26	0.00
605-0900-4855	Gain on Investment	0.00	0.00	467.05	-467.05	0.00	-467.05	0.00
	R85 Sub Totals:	0.00	0.16	467.31	-467.31	0.00	-467.31	0.00
	Revenue Sub Totals:	0.00	0.16	467.31	-467.31	0.00	-467.31	0.00
E62	Intergovernmental Tsfr							
605-0900-5626	Xfer to Other	0.00	0.00	0.10	-0.10	0.00	-0.10	0.00
	E62 Sub Totals:	0.00	0.00	0.10	-0.10	0.00	-0.10	0.00
E85	Interest Expense							
605-0900-5855	Loss on Investment	0.00	486.51	486.51	-486.51	0.00	-486.51	0.00
	E85 Sub Totals:	0.00	486.51	486.51	-486.51	0.00	-486.51	0.00
	Expense Sub Totals:	0.00	486.51	486.61	-486.61	0.00	-486.61	0.00
	Dept 0900 Sub Totals:	0.00	486.35	19.30	-19.30	0.00		
	Fund Revenue Sub Totals:	0.00	0.16	467.31	-467.31	0.00	-467.31	0.00
	Fund Expense Sub Totals:	0.00	486.51	486.61	-486.61	0.00	-486.61	0.00
	Fund 605 Sub Totals:	0.00	486.35	19.30	-19.30	0.00		

Account Number	Description	Budget Amount	Period Amount	YTD Amount	YTD Var	Encumbered Amount	Available	% Available
Fund 610	Wolf Creek Debt Serv							
Dept 610-0900								
R62	Intergovernmental Tsfrs							
610-0900-4626	Xfer from Other	0.00	0.00	0.00	0.00	0.00	0.00	0.00
	R62 Sub Totals:	0.00	0.00	0.00	0.00	0.00	0.00	0.00
R85	Interest Revenue							
610-0900-4850	Interest Revenue	0.00	0.01	0.06	-0.06	0.00	-0.06	0.00
	R85 Sub Totals:	0.00	0.01	0.06	-0.06	0.00	-0.06	0.00
	Revenue Sub Totals:	0.00	0.01	0.06	-0.06	0.00	-0.06	0.00
E60	Miscellaneous Expense							
610-0900-5723	Improvement District Payout	0.00	0.00	0.00	0.00	0.00	0.00	0.00
	E60 Sub Totals:	0.00	0.00	0.00	0.00	0.00	0.00	0.00
E72	Bond Expense							
610-0900-5722	Bond Principal Prnt	0.00	0.00	0.00	0.00	0.00	0.00	0.00
	E72 Sub Totals:	0.00	0.00	0.00	0.00	0.00	0.00	0.00
	Expense Sub Totals:	0.00	0.00	0.00	0.00	0.00	0.00	0.00
	Dept 0900 Sub Totals:	0.00	-0.01	-0.06	0.06	0.00	-0.06	0.00
	Fund Revenue Sub Totals:	0.00	0.01	0.06	-0.06	0.00	-0.06	0.00
	Fund Expense Sub Totals:	0.00	0.00	0.00	0.00	0.00	0.00	0.00
	Fund 610 Sub Totals:	0.00	-0.01	-0.06	0.06	0.00	-0.06	0.00

Account Number	Description	Budget Amount	Period Amount	YTD Amount	YTD Var	Encumbered Amount	Available	% Available
Fund 611	Wolf Creek Bond							
Dept 611-0900								
R15	Taxes - Property							
611-0900-4154	Special Assessment	0.00	0.00	0.00	0.00	0.00	0.00	0.00
	R15 Sub Totals:	0.00	0.00	0.00	0.00	0.00	0.00	0.00
R85	Interest Revenue							
611-0900-4850	Interest Revenue	0.00	0.00	0.00	0.00	0.00	0.00	0.00
	R85 Sub Totals:	0.00	0.00	0.00	0.00	0.00	0.00	0.00
	Revenue Sub Totals:	0.00	0.00	0.00	0.00	0.00	0.00	0.00
E62	Intergovernmental Tsfr							
611-0900-5626	Xfer to other	0.00	0.00	0.00	0.00	0.00	0.00	0.00
	E62 Sub Totals:	0.00	0.00	0.00	0.00	0.00	0.00	0.00
E72	Bond Expense							
611-0900-5722	Bond Principal Pmt	0.00	0.00	0.00	0.00	0.00	0.00	0.00
	E72 Sub Totals:	0.00	0.00	0.00	0.00	0.00	0.00	0.00
E85	Interest Expense							
611-0900-5850	Interest Expense	0.00	0.00	0.00	0.00	0.00	0.00	0.00
	E85 Sub Totals:	0.00	0.00	0.00	0.00	0.00	0.00	0.00
	Expense Sub Totals:	0.00	0.00	0.00	0.00	0.00	0.00	0.00
	Dept 0900 Sub Totals:	0.00	0.00	0.00	0.00	0.00	0.00	0.00
	Fund Revenue Sub Totals:	0.00	0.00	0.00	0.00	0.00	0.00	0.00
	Fund Expense Sub Totals:	0.00	0.00	0.00	0.00	0.00	0.00	0.00
	Fund 611 Sub Totals:	0.00	0.00	0.00	0.00	0.00	0.00	0.00

Account Number	Description	Budget Amount	Period Amount	YTD Amount	YTD Var	Encumbered Amount	Available	% Available
Fund 615	WW Bond 2012 Constr							
Dept 615-0950								
R60	Miscellaneous Revenue							
615-0950-4610	CWRLF Loan	0.00	0.00	0.00	0.00	0.00	0.00	0.00
	R60 Sub Totals:	0.00	0.00	0.00	0.00	0.00	0.00	0.00
	Revenue Sub Totals:							
	Fixed Assets							
E80	FA - ANRC - Pump Station 5	295,000.00	0.00	0.00	295,000.00	0.00	295,000.00	100.00
615-0950-5832	FA - ANRC - Pump Station 25	372,600.00	0.00	0.00	372,600.00	0.00	372,600.00	100.00
615-0950-5834	FA - ANRC -Dewatering Facility	668,997.00	0.00	0.00	668,997.00	0.00	668,997.00	100.00
615-0950-5835	FA - ANRC - 12" Force Main	1,365,900.00	0.00	0.00	1,365,900.00	0.00	1,365,900.00	100.00
615-0950-5836	FA - ANRC - Manhole Rehab	118,877.00	0.00	0.00	118,877.00	0.00	118,877.00	100.00
	E80 Sub Totals:	2,821,374.00	0.00	0.00	2,821,374.00	0.00	2,821,374.00	100.00
E85	Interest Expense							
615-0950-5850	Interest Expense - CWRLF	0.00	0.00	0.00	0.00	0.00	0.00	0.00
	E85 Sub Totals:	0.00	0.00	0.00	0.00	0.00	0.00	0.00
	Expense Sub Totals:	2,821,374.00	0.00	0.00	2,821,374.00	0.00	2,821,374.00	100.00
	Dept 0950 Sub Totals:	2,821,374.00	0.00	0.00	2,821,374.00	0.00	2,821,374.00	100.00
	Fund Revenue Sub Totals:	0.00	0.00	0.00	0.00	0.00	0.00	0.00
	Fund Expense Sub Totals:	2,821,374.00	0.00	0.00	2,821,374.00	0.00	2,821,374.00	100.00
	Fund 615 Sub Totals:	2,821,374.00	0.00	0.00	2,821,374.00	0.00	2,821,374.00	100.00

Account Number	Description	Budget Amount	Period Amount	YTD Amount	YTD Var	Encumbered Amount	Available	% Available
Fund 620	Water Bond 2011 Constr							
Dept 620-0900								
R60	Miscellaneous Revenue							
620-0900-4610	Loan - DWSRF	0.00	56,439.89	56,439.89	-56,439.89	0.00	-56,439.89	0.00
	R60 Sub Totals:	0.00	56,439.89	56,439.89	-56,439.89	0.00	-56,439.89	0.00
	Revenue Sub Totals:							
	Fixed Assets							
E80	Fixed AssetProj-16" Water Main	184,123.00	0.00	0.00	184,123.00	0.00	184,123.00	100.00
620-0900-5816		184,123.00	0.00	0.00	184,123.00	0.00	184,123.00	100.00
	E80 Sub Totals:	184,123.00	0.00	0.00	184,123.00	0.00	184,123.00	100.00
	Interest Expense							
E85	Interest Expense - DWSRF	0.00	0.00	0.00	0.00	0.00	0.00	0.00
620-0900-5850		0.00	0.00	0.00	0.00	0.00	0.00	0.00
	E85 Sub Totals:	0.00	0.00	0.00	0.00	0.00	0.00	0.00
	Expense Sub Totals:	184,123.00	0.00	0.00	184,123.00	0.00	184,123.00	100.00
	Dept 0900 Sub Totals:	184,123.00	-56,439.89	-56,439.89	240,562.89	0.00		
	Fund Revenue Sub Totals:	0.00	56,439.89	56,439.89	-56,439.89	0.00	-56,439.89	0.00
	Fund Expense Sub Totals:	184,123.00	0.00	0.00	184,123.00	0.00	184,123.00	100.00
	Fund 620 Sub Totals:	184,123.00	-56,439.89	-56,439.89	240,562.89	0.00		

Account Number	Description	Budget Amount	Period Amount	YTD Amount	YTD Var	Encumbered Amount	Available	% Available
	Revenue Totals:	46,717,877.53	3,924,975.20	7,606,642.24	9,111,235.29	0.00	39,111,235.29	83.72
	Expense Totals:	52,679,259.07	3,396,370.62	6,911,321.70	5,767,937.37	9,090,136.49	36,677,800.88	69.62
	Report Totals:	5,961,381.54	-528,604.58	-695,320.54	6,656,702.08	9,090,136.49		

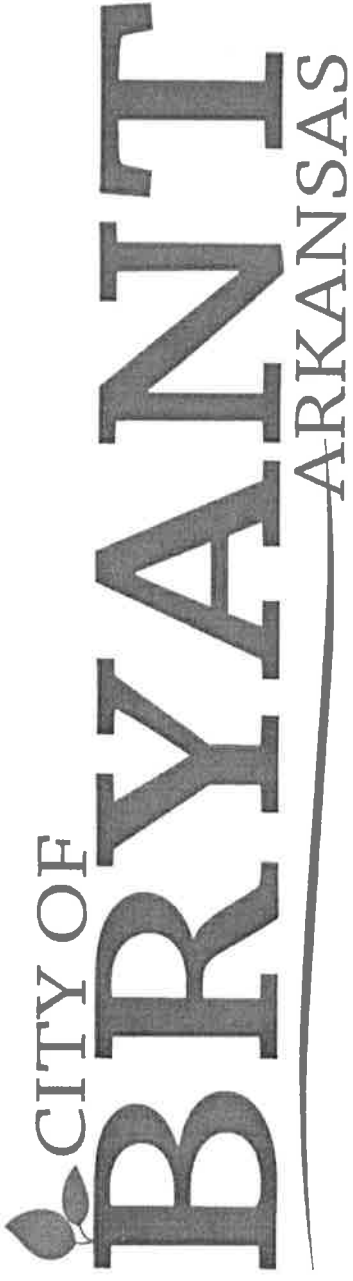

Financial Report

March 2015



General - Executive Summary Revenue & Expenditures

March 2015

Revenues:	Annual Budget	YTD Budget	January	February	March	April	May	June	July	August	September	October	November	December	Actual YTD Total	Favorable (Unfavorable) Variance	Annual Budget Remaining
General	12,059,930	3,014,963	980,810	854,066	1,005,778	-	-	-	-	-	-	-	-	-	2,840,654	(174,329)	9,219,276
Administration	4,986,120	1,246,530.00	371,926	346,288	452,184	-	-	-	-	-	-	-	-	-	1,170,399	(76,131)	3,815,721
PCD	8,100	2,025.00	125	1,137	-	-	-	-	-	-	-	-	-	-	1,262	(763)	6,839
Animal Control	419,000	104,750.00	34,706	34,027	34,811	-	-	-	-	-	-	-	-	-	103,544	(1,206)	315,456
Court	731,950	182,987.50	94,249	43,718	52,093	-	-	-	-	-	-	-	-	-	190,060	7,073	541,890
Parks	2,008,450	502,112.50	171,220	148,743	165,447	-	-	-	-	-	-	-	-	-	485,410	(16,703)	1,523,040
Fire	2,450,000	612,500.00	185,417	185,443	187,581	-	-	-	-	-	-	-	-	-	558,441	(54,059)	1,891,559
Police	1,299,400	324,850.00	80,000	80,000	101,598	-	-	-	-	-	-	-	-	-	261,598	(63,252)	1,037,802
Code	156,910	39,227.50	43,167	14,709	12,063	-	-	-	-	-	-	-	-	-	69,939	30,712	86,971
Total Revenues	19,059,930	3,014,963	980,810	854,066	1,005,778	-	-	-	-	-	-	-	-	-	2,840,654	(174,329)	9,219,276
Expenditures:																	
General	12,077,162	3,019,291	1,203,650	901,337	731,750	-	-	-	-	-	-	-	-	-	2,836,738	182,553	9,240,425
Administration	950,921	237,730.24	100,928	81,184	33,303	-	-	-	-	-	-	-	-	-	215,414	22,316	735,507
PCD (includes \$29K MS*	256,323	64,080.82	15,896	12,783	11,789	-	-	-	-	-	-	-	-	-	40,468	23,612	215,855
Animal Control	364,548	91,136.92	30,923	26,629	25,590	-	-	-	-	-	-	-	-	-	83,132	8,005	281,416
Court	413,009	103,252.13	33,677	28,162	26,918	-	-	-	-	-	-	-	-	-	88,747	14,505	324,261
Parks	2,309,199	577,299.67	177,193	163,480	162,831	-	-	-	-	-	-	-	-	-	503,504	73,796	1,805,695
Fire	3,417,259	854,314.87	416,402	257,593	206,907	-	-	-	-	-	-	-	-	-	890,902	(26,587)	2,536,358
Police	4,104,961	1,026,240.26	402,898	310,378	239,884	-	-	-	-	-	-	-	-	-	952,960	73,280	3,152,001
Code	260,943	65,235.68	25,934	21,139	24,538	-	-	-	-	-	-	-	-	-	71,611	(6,375)	189,332
Total Expenditures	19,077,162	3,019,291	1,203,650	901,337	731,750	-	-	-	-	-	-	-	-	-	2,836,738	182,553	9,240,425
Excess (Deficit) of Revenues over Expenditures																	
	(17,232)	(4,308)	(22,841)	(47,271)	274,028	-	-	-	-	-	-	-	-	-	3,916	-	-

Street - Executive Summary Revenue & Expenditures

Revenues:	Annual Budget	YTD Budget	January	February	March	April	May	June	July	August	September	October	November	December	Actual YTD Total	Favorable (Unfavorable) Variance	Annual Budget Remaining
Street	2,808,100	702,025	193,503	184,984	188,421	-	-	-	-	-	-	-	-	-	566,909	(1,135,116)	2,241,181
Total Revenues	2,808,100	702,025	193,503	184,984	188,421	-	-	-	-	-	-	-	-	-	566,909	(1,135,116)	2,241,181
Expenditures:																	
Street	3,121,818	780,454	127,617	108,504	147,243	-	-	-	-	-	-	-	-	-	383,364	397,050	2,738,453
Total Expenditures	3,121,818	780,454	127,617	108,504	147,243	-	-	-	-	-	-	-	-	-	383,364	397,050	2,738,453
Excess (Deficit) of Revenues over Expenditures																	
	(313,718)	(78,429)	65,886	76,480	41,178	-	-	-	-	-	-	-	-	-	183,544	-	-

City Sales & Use Tax (Three Cent Sales Tax)

	January	February	March	April	May	June	July	August	September	October	November	December	YTD Total
2014	963,538	1,021,873	808,370										2,793,781
2015	902,020	1,162,729	817,653										2,882,402
Difference	(61,518)	140,855	9,283										88,620
	-6%	14%	1%										3%

2014 Actual	2,793,781
Estimated 1%	27,938
2015 Projected	2,821,719
2015 Actual	2,882,402
(Short)/Over	\$ 60,683

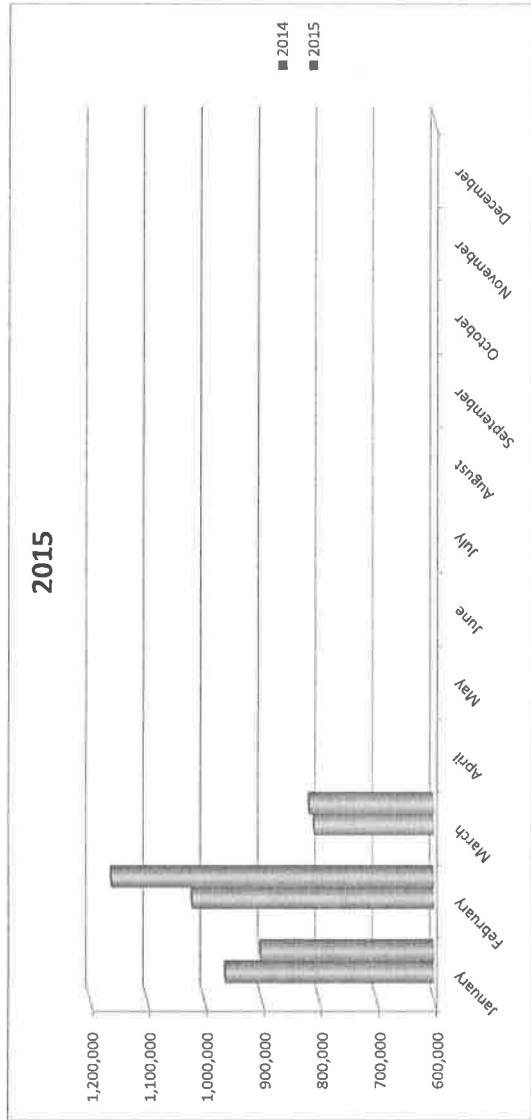



Cash Reserves

March 2015

General Funds:	120 days cash = \$4M			
	001	Operating Acct	2,550,847	Days
	005	Designated Tax	717,711	
	002	Sales Tax Fund	402,235	
	003	Franchise Fees	595,156	
	060	Police Donation	1,756	
	050	Fire Donation	2,653	
	045	Park 1/8 Tax	49,274	
	055	Fire 3/8 Tax	285,088	
	020	Animal Donation	10,581	
			<u>4,615,301</u>	<u>138</u>

Street Funds:	120 days cash = \$789k		
	080	Operating Acct	1,471,860
	080	CD's	350,000
	005	Designated Tax	650,322
			<u>2,472,182</u>
			<u>(50,000)</u>
			<u>(350,000)</u>
			<u>2,072,182</u>
			<u>376</u>
			<u>-8</u>
			<u>-53</u>
			<u>315</u>

Designated Tax Fund Summary			
Administration	\$	80,253	
Animal Control	\$	116,310	
Parks	\$	331	
Fire	\$	152,855	
Police	\$	367,961	
Street	\$	650,322	
Total	\$	1,368,033	

Springhill Fire Department Summary			
Beginning Balance (as of January 1, 2015)	\$	121,887	
2015 Revenue (Act 001-0510-4152)	\$	1,879	
2015 Expenses (Act 001-0500-5830)	\$	821	
Current Balance (as of October 31, 2014)	\$	<u>122,945</u>	

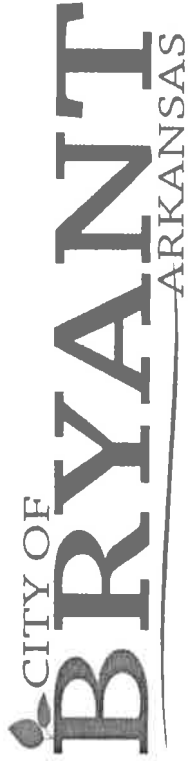

Water Cash Reserves

March 2015

*Reevaluated quarter ending 9/30/14

Water				
Funds:				
	120 days cash = \$1.1M			
	500	Operating Acct	4,343,642	
	510	Revenue Fund	2,666,557	
			<u>7,010,199</u>	765
	Reserved - Capital Infrastructure	510-0900-5816	(300,000)	-33
	Reserved -Other Equipment	510-0900-5821	(335,000)	-37
	Reserved - Misc Capital	510-0900-58XX	(158,000)	-17
	Reserved - Snooks Lane Ext	510-0900-5828	(285,000)	-31
	Reserved - Dewatering Facility	510-0950-5817	(1,432,758)	-156
	Reserved - Capital Infrastructure	510-0950-5816	(300,000)	-33
			<u>4,199,441</u>	458

	001	002	003	005	020	030	031	045	050	051	055	059	060	061	062	068
	General Fund	Sales Tax Fund	Franchise Fees	Designated Tax Fund	Animal Control Donation	Act 1256 of 1995	Act 1809 of 2001	Park 1/8 Sales Tax O&M	Fire Donation	Act 833 Of 1991	Fire 3/8 Sales Tax	Firemen's Pension	Police Donation	Act 918 of 1983	Act 988 of 1991	State Drug Control
REVENUE																
Taxes - Sales	30,166	272,456	105444.03					34,069			102,207					
Taxes - Property																
Licenses Permits & Fees	14,724															
Membership Fees	54,361															
Rental Fees	9,478															
Park Program Fees	13,153															
Fines & Forfeitures	52,250					29,777	4,221							1,343	1,065	
Sales of Services	13,673															
Miscellaneous Rev	21,160															
Intergovernmental	793,863			272,551												
Reimbursement																
Sale of Equipment																
Donation Revenue																
Grant Revenue																
Bond Revenue																
Donation Revenue																
Sponsorships	2,867															
Interest Revenue	86	21	29	63	1		3		0	1	14	170	0	1	1	0
Total Revenue	1,005,780	272,477	105,473	272,614	1	29,777	4,223	34,071	0	1	102,221	170	0	1,344	1,066	0
Expense																
Personnel Cost	573,079											1,210				
Building & Ground Exp	49,182															
Vehicle Expense	(17,598)															
Supply Expense	23,738															
Operations Expense	43,938					29,777										
Professional Services	35,071															
Miscellaneous	23,713						1,861									25
Intergovernmental Reimbursement	2,437	319,583	164,076	313,250				40,000			105,417					
Sale of Equipment																
Contract Expense																
Grant Expense	12,029															
Bond Expense																
Fixed Assets	(13,837)															
Interest Expense																
Construction Projects																
Total Expense	731,750	319,583	164,076	313,250		29,777	1,861	40,000			134,732	1,783				25
Change in Fund																
Balance/Net Position Beginning Fund	274,030	(47,106)	(58,603)	(40,636)	1		2,363	(5,929)	0	1	(32,511)	(1,612)	0	1,344	1,066	(25)
Balance/Net Position Ending Fund	2,276,818	449,341	653,758	1,408,670	10,581	21	58,967	55,202	2,653	30,031	317,600	80,988	1,756	27,168	24,699	8,268
Balance/Net Position	2,550,847	402,235	595,156	1,368,033	10,581	21	61,330	49,274	2,653	30,033	285,088	79,376	1,756	28,512	25,765	8,243

REVENUE	080	140	141	142	143	144	145	146	180	181	182	500	510	520	525
	Street Fund	Park Bond 2006 DS	Park Bond 2006 DSR	Park Bond O&M	Park Bond 2007 DS	Park Bond 2007 DSR	Park Bond 2010 DS	Park Bond 2010 DSR	Street Bond 2008 Constr	Street Bond 2008 DSR	Street Bond 2008 DS	Revenue Water	Water Operating	Depreciation Water	Depreciation WW
Taxes - Sales	24,774	68,138		34,069	68,138										
Taxes - Property	74,166														
Licenses Permits & Fees															
Memberships Fees															
Rental Fees															
Park Program Fees															
Fines & Forfeitures															
Sales of Services												560,940			
Miscellaneous Rev															
Intergovernmental	89,417						0	0		419		5,942	771,700		15,287
Reimbursement															
Sale of Equipment															
Donation Revenue															
Grant Revenue															
Bond Revenue															
Sponsorships															
Interest Revenue	65	4	148	0	4	190	1	270	3	209	4				
Total Revenue	188,421	68,142	148	34,069	68,142	190	1	270	3	209	423	566,882	771,700	15,287	(8)
Expense															
Personnel Cost	77,896												125,416		
Building & Ground Exp	4,291												32,913		
Vehicle Expense	9,965												5,859		
Supply Expense	857												93,850		
Operations Expense	27,612											4,975	12,014		
Professional Services	4,646												5,387		
Miscellaneous	261												1,591		
Intergovernmental			0	34,069						419		780,065	15,287		
Reimbursement															
Sale of Equipment															
Contract Expense															
Grant Expense															
Bond Expense		418,293			308,167							59,947	20,364		
Fixed Assets	3,959												51,164		
Interest Expense													14,766		
Construction Projects	17,754														
Total Expense	147,243	418,293	0	34,069	308,167	190	419	270	3	209	423	844,987	378,612	15,287	(8)
Change in Fund															
Balance/Net Position Beginning Fund	41,178	(350,151)	148	0	(240,025)	190	1	270	3	(209)	423	(278,105)	393,089		15,278
Balance/Net Position Ending Fund	1,780,682	659,230	261,669	2	665,253	340,256	39,853	183,987	33,648	176,802	128,130	2,944,662	3,918,112	5	656,152
Balance/Net Position	1,821,860	309,080	261,817	2	425,229	340,446	39,854	184,257	33,651	176,592	128,553	2,666,557	4,311,200	5	671,430

General Ledger

Budget Status

User: emccallum
 Printed: 4/20/2015 - 10:49 AM
 Period: 3, 2015

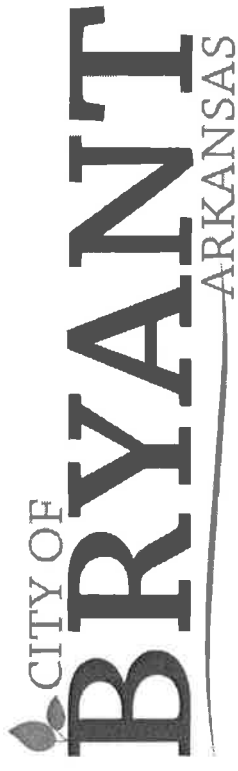

Account Number	Description	Budget Amount	Period Amount	YTD Amount	YTD Var	Encumbered Amount	Available	% Available
Fund 001	General Fund							
Dept 001-0000	Intergovernmental Tsfr							
E62	Xfer to Other	0.00	2,436.59	2,436.59	-2,436.59	0.00	-2,436.59	0.00
001-0000-5620	E62 Sub Totals:	0.00	2,436.59	2,436.59	-2,436.59	0.00	-2,436.59	0.00
	Expense Sub Totals:	0.00	2,436.59	2,436.59	-2,436.59	0.00	-2,436.59	0.00
Dept 001-0100	Dept 0000 Sub Totals:	0.00	2,436.59	2,436.59	-2,436.59	0.00		
R15	Administration							
001-0100-4150	Taxes - Property	245,000.00	18,238.81	71,533.75	173,466.25	0.00	173,466.25	70.80
001-0100-4151	State Turnback	485,000.00	9,761.47	35,049.05	449,950.95	0.00	449,950.95	92.77
	Saline County Treas - Turnback							
R15 Sub Totals:		730,000.00	28,000.28	106,582.80	623,417.20	0.00	623,417.20	85.40
R60	Miscellaneous Revenue							
001-0100-4600	Miscellaneous Revenue	1,000.00	-515.13	-215.87	1,215.87	0.00	1,215.87	121.59
R60 Sub Totals:		1,000.00	-515.13	-215.87	1,215.87	0.00	1,215.87	121.59
R62	Intergovernmental Tsfrs							
001-0100-4627	Xfer from Sales Tax	3,835,000.00	319,583.33	958,749.99	2,876,250.01	0.00	2,876,250.01	75.00
001-0100-4629	Xfer Franchise Tax Fd21	420,120.00	105,030.00	105,030.00	315,090.00	0.00	315,090.00	75.00
R62 Sub Totals:		4,255,120.00	424,613.33	1,063,779.99	3,191,340.01	0.00	3,191,340.01	75.00
R85	Interest Revenue							
001-0100-4850	Interest Revenue	0.00	85.72	251.79	-251.79	0.00	-251.79	0.00
R85 Sub Totals:		0.00	85.72	251.79	-251.79	0.00	-251.79	0.00
Revenue Sub Totals:		4,986,120.00	452,184.20	1,170,398.71	3,815,721.29	0.00	3,815,721.29	76.53
E01	Personnel Expense							
001-0100-5000	Salary Expense	469,904.11	35,850.44	135,583.39	334,320.72	0.00	334,320.72	71.15
001-0100-5001	Elected Officials Salary Exp	175,409.62	13,888.18	46,571.64	128,837.98	0.00	128,837.98	73.45

Account Number	Description	Budget Amount	Period Amount	YTD Amount	YTD Var	Encumbered Amount	Available	% Available
001-0100-5005	SWB Reimbursement	-545,000.00	-99,916.63	-122,249.95	-422,750.05	0.00	-422,750.05	0.00
001-0100-5010	Overtime Expense	10,000.00	89.87	477.77	9,522.23	0.00	9,522.23	95.22
001-0100-5020	FICA Expense	56,797.30	3,806.07	13,906.59	42,890.71	0.00	42,890.71	75.52
001-0100-5022	Unemployment Expense	3,960.00	0.00	50.33	3,909.67	0.00	3,909.67	98.73
001-0100-5025	Worker's Comp Expense	3,500.00	0.00	3,367.34	132.66	0.00	132.66	3.79
001-0100-5030	APERS Expense	102,218.10	6,699.19	24,390.91	77,827.19	0.00	77,827.19	76.14
001-0100-5038	Pension Expense	2,200.00	179.37	538.11	1,661.89	1,614.33	47.56	2.16
001-0100-5040	Health Insurance Expense	84,654.36	6,524.62	20,717.18	63,937.18	0.00	63,937.18	75.53
001-0100-5042	Employee Assistance Program	5,000.00	479.00	1,916.00	3,084.00	0.00	3,084.00	61.68
001-0100-5044	Legal Services Expense	30,000.00	2,500.00	7,500.00	22,500.00	22,500.00	0.00	0.00
001-0100-5050	Physical & Drug Screen Exp	600.00	0.00	0.00	600.00	0.00	600.00	100.00
001-0100-5055	Uniform Expense	700.00	0.00	174.26	525.74	0.00	525.74	75.11
001-0100-5057	Vehicle Allowance	8,000.00	461.52	1,615.32	6,384.68	0.00	6,384.68	79.81
001-0100-5060	Travel & Training Expense	12,940.00	838.24	1,336.39	11,603.61	247.51	11,356.10	87.76
001-0100-5065	First Aid Expense	100.00	0.00	0.00	100.00	0.00	100.00	100.00
E01 Sub Totals:		420,983.49	-28,600.13	135,895.28	285,088.21	24,361.84	260,726.37	61.93
E10	Building & Grounds Exp							
001-0100-5102	Repairs & Maint - Building	1,350.00	273.35	273.35	1,076.65	455.76	620.89	45.99
001-0100-5104	Repairs & Maint - Grounds	1,000.00	402.42	457.49	542.51	468.09	74.42	7.44
001-0100-5110	Utilities - Electric	11,000.00	923.58	2,097.28	8,902.72	0.00	8,902.72	80.93
001-0100-5111	Utilities - Gas	1,600.00	185.74	555.83	1,044.17	0.00	1,044.17	65.26
001-0100-5112	Utilities - Water	1,200.00	-14.00	209.36	990.64	0.00	990.64	82.55
001-0100-5115	Communication Exp - Telephone	17,500.00	0.00	2,308.01	15,191.99	910.93	14,281.06	81.61
001-0100-5116	Communication Exp - Cellular	6,500.00	603.42	1,854.54	4,645.46	8.99	4,636.47	71.33
001-0100-5120	Insurance - Property	2,000.00	0.00	0.00	2,000.00	0.00	2,000.00	100.00
001-0100-5130	Sanitation	2,500.00	86.24	258.72	2,241.28	86.24	2,155.04	86.20
001-0100-5142	Janitorial Supplies - B&G	1,500.00	972.14	1,047.91	452.09	0.00	452.09	30.14
E10 Sub Totals:		46,150.00	3,432.89	9,062.49	37,087.51	1,930.01	35,157.50	76.18
E20	Vehicle Expense							
001-0100-5200	Fuel Expense	1,500.00	58.90	207.90	1,292.10	0.00	1,292.10	86.14
001-0100-5225	Insurance Expense - Vehicle	1,000.00	0.00	305.00	695.00	0.00	695.00	69.50
E20 Sub Totals:		2,500.00	58.90	512.90	1,987.10	0.00	1,987.10	79.48
E30	Supply Expense							
001-0100-5061	Training Aids-Administration	500.00	0.00	0.00	500.00	0.00	500.00	100.00
001-0100-5212	Office Equip Purch/Mnt-Admin	1,500.00	0.00	0.00	1,500.00	0.00	1,500.00	100.00
001-0100-5300	Supplies - Office	5,000.00	746.83	947.62	4,052.38	435.06	3,617.32	72.35
001-0100-5334	Supplies - Volunteer	2,000.00	0.00	0.00	2,000.00	0.00	2,000.00	100.00
001-0100-5350	Postage Expense	3,000.00	0.00	1,728.04	1,271.96	0.00	1,271.96	42.40
E30 Sub Totals:		12,000.00	746.83	2,675.66	9,324.34	435.06	8,889.28	74.08
E40	Operations Expense							

Account Number	Description	Budget Amount	Period Amount	YTD Amount	YTD Var	Encumbered Amount	Available	% Available
001-0100-5480	Dues & Subscriptions	7,200.00	110.00	153.53	7,046.47	152.00	6,894.47	95.76
001-0100-5481	Municipal/Metro Dues-Admin	55,000.00	15,653.00	15,828.00	39,172.00	0.00	39,172.00	71.22
001-0100-5505	Mayor's Expense	5,000.00	0.00	0.00	5,000.00	0.00	5,000.00	100.00
001-0100-5506	City Clerk Expense	2,800.00	190.17	349.59	2,450.41	0.00	2,450.41	87.51
001-0100-5510	Meeting Expense	600.00	16.35	16.35	583.65	0.00	583.65	97.28
	E40 Sub Totals:	70,600.00	15,969.52	16,347.47	54,252.53	152.00	54,100.53	76.63
E55	Professional Services							
001-0100-5553	Prof Services - Advertising	7,500.00	884.30	1,040.90	6,459.10	454.44	6,004.66	80.06
001-0100-5583	Prof Services - Legal	24,000.00	3,079.50	4,089.50	19,910.50	0.00	19,910.50	82.96
001-0100-5586	Prof. Services - Other	33,000.00	8,841.00	9,057.59	23,942.41	0.00	23,942.41	72.55
001-0100-5588	Prof Services - Legal Notices	2,500.00	0.00	0.00	2,500.00	1,483.20	1,016.80	40.67
001-0100-5589	Prof Services - Printing	5,000.00	444.70	1,415.11	3,584.89	305.10	3,279.79	65.60
	E55 Sub Totals:	72,000.00	13,249.50	15,603.10	56,396.90	2,242.74	54,154.16	75.21
E60	Miscellaneous Expense							
001-0100-5062	Travel & Training - Mayor	3,500.00	440.20	1,099.20	2,400.80	0.00	2,400.80	68.59
001-0100-5063	Travel & Training - City Clerk	3,325.00	113.92	113.92	3,211.08	315.76	2,895.32	87.08
001-0100-5101	Misc. Expense-Admin	500.00	43.90	450.34	49.66	13.61	36.05	7.21
001-0100-5600	Miscellaneous Expense	100.00	0.00	0.00	100.00	0.00	100.00	100.00
	E60 Sub Totals:	7,425.00	598.02	1,663.46	5,761.54	329.37	5,432.17	73.16
E64	Reimbursement							
001-0100-5146	Building & Ground Reim. Court	-24,605.00	0.00	0.00	-24,605.00	0.00	-24,605.00	0.00
001-0100-5147	Building & Grounds Reim PC & D	-7,030.00	0.00	0.00	-7,030.00	0.00	-7,030.00	0.00
001-0100-5148	Building & Ground Reim-Water	-7,030.00	0.00	0.00	-7,030.00	0.00	-7,030.00	0.00
	E64 Sub Totals:	-38,665.00	0.00	0.00	-38,665.00	0.00	-38,665.00	0.00
E68	Donation Expense							
001-0100-5680	Boys and Girls Club Contract	35,000.00	8,750.00	8,750.00	26,250.00	0.00	26,250.00	75.00
001-0100-5681	Sr. Adults Contract	20,000.00	0.00	0.00	20,000.00	0.00	20,000.00	100.00
001-0100-5682	Historic Society Contract	10,000.00	0.00	0.00	10,000.00	0.00	10,000.00	100.00
	E68 Sub Totals:	65,000.00	8,750.00	8,750.00	56,250.00	0.00	56,250.00	86.54
E80	Fixed Assets							
001-0100-5816	Fixed Asse2011 Ridg Prop Aquis	37,451.78	0.00	0.00	37,451.78	0.00	37,451.78	100.00
	E80 Sub Totals:	37,451.78	0.00	0.00	37,451.78	0.00	37,451.78	100.00
E85	Interest Expense							
001-0100-5850	Interest Expense	2,497.70	0.00	0.00	2,497.70	0.00	2,497.70	100.00
	E85 Sub Totals:	2,497.70	0.00	0.00	2,497.70	0.00	2,497.70	100.00

Account Number	Description	Budget Amount	Period Amount	YTD Amount	YTD Var	Encumbered Amount	Available	% Available
Dept 001-01110	Expense Sub Totals:	697,942.97	14,205.53	190,510.36	507,432.61	29,451.02	477,981.59	68.48
E60	Dept 0100 Sub Totals:	-4,288,177.03	-437,978.67	-979,888.35	3,308,288.68	29,451.02		
001-01110-5604	Miscellaneous Expense	49,458.00	0.00	40.75	49,417.25	0.00	49,417.25	99.92
001-01110-5606	Computer Hardware	125,120.00	13,700.00	17,892.30	107,227.70	0.00	107,227.70	85.70
001-01110-5608	Computer Maint & Support	37,300.00	0.00	0.00	37,300.00	0.00	37,300.00	100.00
001-01110-5610	Computer Software	6,500.00	0.00	0.00	6,500.00	0.00	6,500.00	100.00
001-01110-5612	Website Expense	1,000.00	0.00	0.00	1,000.00	0.00	1,000.00	100.00
001-01110-5614	Tools - IT	33,600.00	2,960.62	4,533.90	29,066.10	17,647.16	11,418.94	33.98
	Copier Maint & Lease							
E60 Sub Totals:		252,978.00	16,660.62	22,466.95	230,511.05	17,647.16	212,863.89	84.14
Expense Sub Totals:		252,978.00	16,660.62	22,466.95	230,511.05	17,647.16	212,863.89	84.14
Dept 001-0120	Dept 0110 Sub Totals:	252,978.00	16,660.62	22,466.95	230,511.05	17,647.16		
R20	Licenses Permits & Fees	1,000.00	0.00	100.00	900.00	0.00	900.00	90.00
001-0120-4206	Annex/Rezoning Fees	7,000.00	0.00	1,162.00	5,838.00	0.00	5,838.00	83.40
001-0120-4250	Subdivision Plat & Filing Fees							
R20 Sub Totals:		8,000.00	0.00	1,262.00	6,738.00	0.00	6,738.00	84.23
R50	Sale of Services	100.00	0.00	0.00	100.00	0.00	100.00	100.00
001-0120-4538	Plotter Copies - PC Dev							
R50 Sub Totals:		100.00	0.00	0.00	100.00	0.00	100.00	100.00
Revenue Sub Totals:		8,100.00	0.00	1,262.00	6,838.00	0.00	6,838.00	84.42
E01	Personnel Expense	98,243.72	7,481.78	25,677.94	72,565.78	0.00	72,565.78	73.86
001-0120-5000	Salary Expense	500.00	0.00	0.00	500.00	0.00	500.00	100.00
001-0120-5010	Overtime Expense	7,553.89	562.09	1,930.86	5,623.03	0.00	5,623.03	74.44
001-0120-5020	FICA Expense	720.00	0.00	0.00	720.00	0.00	720.00	100.00
001-0120-5022	Unemployment Expense	500.00	0.00	228.82	271.18	0.00	271.18	54.24
001-0120-5025	Worker's Comp Expense	12,862.82	971.46	3,391.51	9,471.31	0.00	9,471.31	73.63
001-0120-5030	APERS Expense	13,587.84	1,132.32	3,476.96	10,110.88	0.00	10,110.88	74.41
001-0120-5040	Health Insurance Expense	150.00	0.00	0.00	150.00	0.00	150.00	100.00
001-0120-5050	Physical & Drug Screen Exp	1,000.00	0.00	0.00	1,000.00	0.00	1,000.00	100.00
001-0120-5060	Travel & Training Expense							
E01 Sub Totals:		135,118.27	10,147.65	34,706.09	100,412.18	0.00	100,412.18	74.31
E10	Building & Grounds Exp							

Account Number	Description	Budget Amount	Period Amount	YTD Amount	YTD Var	Encumbered Amount	Available	% Available
001-0120-5100	Building & Grounds Reim	5,530.00	0.00	0.00	5,530.00	0.00	5,530.00	100.00
001-0120-5110	Utilities - Electric	1,400.00	230.88	344.30	1,055.70	0.00	1,055.70	75.41
001-0120-5111	Utilities - Gas	500.00	46.43	138.94	361.06	0.00	361.06	72.21
001-0120-5113	Utilities-Water	0.00	11.46	24.99	-24.99	0.00	-24.99	0.00
001-0120-5115	Communication Exp - Telephone	2,100.00	0.00	321.48	1,778.52	107.16	1,671.36	79.59
001-0120-5116	Communication Exp - Cellular	1,400.00	55.96	183.80	1,216.20	0.00	1,216.20	86.87
001-0120-5130	Sanitation - Planning	300.00	21.56	64.70	235.30	21.56	213.74	71.25
	E10 Sub Totals:	11,230.00	366.29	1,078.21	10,151.79	128.72	10,023.07	89.25
E30	Supply Expense							
001-0120-5300	Supplies - Office	1,500.00	0.00	0.00	1,500.00	200.00	1,300.00	86.67
001-0120-5350	Postage Expense	1,000.00	0.00	0.00	1,000.00	0.00	1,000.00	100.00
	E30 Sub Totals:	2,500.00	0.00	0.00	2,500.00	200.00	2,300.00	92.00
E40	Operations Expense							
001-0120-5480	Dues & Subscriptions	49,000.00	0.00	1,454.66	47,545.34	0.00	47,545.34	97.03
001-0120-5510	Meeting Expense	100.00	0.00	0.00	100.00	0.00	100.00	100.00
	E40 Sub Totals:	49,100.00	0.00	1,454.66	47,645.34	0.00	47,645.34	97.04
E55	Professional Services							
001-0120-5553	Prof Services - Advertising	2,000.00	230.20	230.20	1,769.80	124.50	1,645.30	82.27
001-0120-5571	Prof Services - Engineering	12,240.00	1,020.00	2,890.17	9,349.83	0.00	9,349.83	76.39
001-0120-5574	Prof Services - GIS	6,120.00	0.00	0.00	6,120.00	0.00	6,120.00	100.00
001-0120-5589	Prof Services - Printing	350.00	25.00	75.00	275.00	0.00	275.00	78.57
	E55 Sub Totals:	20,710.00	1,275.20	3,195.37	17,514.63	124.50	17,390.13	83.97
E60	Miscellaneous Expense							
001-0120-5608	Computer Software	7,310.00	0.00	0.00	7,310.00	0.00	7,310.00	100.00
	E60 Sub Totals:	7,310.00	0.00	0.00	7,310.00	0.00	7,310.00	100.00
E70	Grant Expense							
001-0120-5610	Grant Exp - Jump Start	2,000.00	0.00	33.89	1,966.11	0.00	1,966.11	98.31
	E70 Sub Totals:	2,000.00	0.00	33.89	1,966.11	0.00	1,966.11	98.31
	Expense Sub Totals:	227,968.27	11,789.14	40,468.22	187,500.05	453.22	187,046.83	82.05
	Dept 0120 Sub Totals:	219,868.27	11,789.14	39,206.22	180,662.05	453.22		
Dept 001-0140	Personnel Expense							
E01	Worker's Comp Expense	0.00	0.00	0.00	0.00	0.00	0.00	0.00
001-0140-5025								
	E01 Sub Totals:	0.00	0.00	0.00	0.00	0.00	0.00	0.00

Account Number	Description	Budget Amount	Period Amount	YTD Amount	YTD Var	Encumbered Amount	Available	% Available
E90	Construction Projects							
001-0140-5901	Project - Forest Cove Grant Pr	25,000.00	0.00	0.00	25,000.00	0.00	25,000.00	100.00
	E90 Sub Totals:	25,000.00	0.00	0.00	25,000.00	0.00	25,000.00	100.00
	Expense Sub Totals:	25,000.00	0.00	0.00	25,000.00	0.00	25,000.00	100.00
	Dept 0140 Sub Totals:	25,000.00	0.00	0.00	25,000.00	0.00		
Dept 001-0200	Licenses Permits & Fees							
R20	Adoption Revenue	4,000.00	310.00	735.00	3,265.00	0.00	3,265.00	81.63
001-0200-4202	Misc Revenue - Animal Control	10,000.00	843.00	1,932.45	8,067.55	0.00	8,067.55	80.68
001-0200-4222	Dog License Fee	3,000.00	67.00	440.50	2,559.50	0.00	2,559.50	85.32
001-0200-4246	Spay & Neuter Revenue	13,000.00	1,440.00	3,420.00	9,580.00	0.00	9,580.00	73.69
	R20 Sub Totals:	30,000.00	2,660.00	6,527.95	23,472.05	0.00	23,472.05	78.24
R40	Fines & Forfeitures							
001-0200-4420	Animal Control Fines	6,000.00	234.00	929.00	5,071.00	0.00	5,071.00	84.52
	R40 Sub Totals:	6,000.00	234.00	929.00	5,071.00	0.00	5,071.00	84.52
R62	Intergovernmental Tsfrs							
001-0200-4627	Xfer Designated Tax	383,000.00	31,916.66	95,749.98	287,250.02	0.00	287,250.02	75.00
	R62 Sub Totals:	383,000.00	31,916.66	95,749.98	287,250.02	0.00	287,250.02	75.00
R68	Donation Revenue							
001-0200-4680	Donation - Animal Shelter	0.00	0.00	317.25	-317.25	0.00	-317.25	0.00
001-0200-4682	Donation - Dog Park	0.00	0.00	20.00	-20.00	0.00	-20.00	0.00
	R68 Sub Totals:	0.00	0.00	337.25	-337.25	0.00	-337.25	0.00
	Revenue Sub Totals:	419,000.00	34,810.66	103,544.18	315,455.82	0.00	315,455.82	75.29
E01	Personnel Expense							
001-0200-5000	Salary Expense	151,540.54	11,222.79	39,585.74	111,954.80	0.00	111,954.80	73.88
001-0200-5005	SWB Reimbursement	43,600.00	3,633.33	10,899.99	32,700.01	0.00	32,700.01	75.00
001-0200-5010	Overtime Expense	11,000.00	1,335.29	3,800.70	7,199.30	0.00	7,199.30	65.45
001-0200-5020	FICA Expense	12,740.16	934.79	3,236.46	9,503.70	0.00	9,503.70	74.60
001-0200-5022	Unemployment Expense	2,147.84	0.00	66.43	2,081.41	0.00	2,081.41	96.91
001-0200-5025	Worker's Comp Expense	500.00	0.00	172.29	327.71	0.00	327.71	65.54
001-0200-5030	APERS Expense	23,888.44	1,853.58	6,403.89	17,484.55	0.00	17,484.55	73.19
001-0200-5040	Health Insurance Expense	37,206.68	2,650.96	7,659.88	29,546.80	0.00	29,546.80	79.41
001-0200-5050	Physical & Drug Screen Exp	450.00	0.00	0.00	450.00	0.00	450.00	100.00
001-0200-5055	Uniform Expense	2,500.00	0.00	644.32	1,855.68	187.10	1,668.58	66.74
001-0200-5060	Travel & Training Expense	3,355.00	611.24	611.24	2,743.76	809.68	1,934.08	57.65

Account Number	Description	Budget Amount	Period Amount	YTD Amount	YTD Var	Encumbered Amount	Available	% Available
001-0200-5065	First Aid Expense	500.00	0.00	0.00	500.00	0.00	500.00	100.00
E01 Sub Totals:		289,428.66	22,241.98	73,080.94	216,347.72	996.78	215,350.94	74.41
E10	Building & Grounds Exp							
001-0200-5102	Repairs & Maint - Building	2,000.00	0.00	0.00	2,000.00	0.00	2,000.00	100.00
001-0200-5104	Repairs & Maint - Grounds	2,000.00	0.00	0.00	2,000.00	0.00	2,000.00	100.00
001-0200-5110	Utilities - Electric	8,000.00	0.00	2,003.60	5,996.40	1,380.57	4,615.83	57.70
001-0200-5111	Utilities - Gas	500.00	118.89	170.39	329.61	0.00	329.61	65.92
001-0200-5112	Utilities - Water	800.00	-5.61	171.90	628.10	0.00	628.10	78.51
001-0200-5115	Communication Exp - Telephone	5,500.00	618.63	1,606.91	3,893.09	743.12	3,149.97	57.27
001-0200-5120	Insurance - Property	1,200.00	0.00	0.00	1,200.00	0.00	1,200.00	100.00
001-0200-5125	Alarm	800.00	63.50	127.00	673.00	63.50	609.50	76.19
001-0200-5130	Sanitation	1,500.00	125.41	376.23	1,123.77	125.41	998.36	66.56
001-0200-5140	Supplies - B&G	500.00	22.93	22.93	477.07	148.32	328.75	65.75
001-0200-5145	Tools	1,200.00	286.22	291.67	908.33	0.00	908.33	75.69
E10 Sub Totals:		24,000.00	1,229.97	4,770.63	19,229.37	2,460.92	16,768.45	69.87
E20	Vehicle Expense							
001-0200-5200	Fuel Expense	8,999.00	308.76	965.13	8,033.87	0.00	8,033.87	89.28
001-0200-5210	Service & Repair - Vehicle	2,000.00	0.00	15.50	1,984.50	95.06	1,889.44	94.47
001-0200-5212	Service & Repair - Equipment	200.00	0.00	0.00	200.00	0.00	200.00	100.00
001-0200-5213	Equipment Repairs - Tires	1,000.00	0.00	0.00	1,000.00	0.00	1,000.00	100.00
001-0200-5225	Insurance Expense - Vehicle	1,065.00	0.00	1,061.39	3.61	0.00	3.61	0.34
E20 Sub Totals:		13,264.00	308.76	2,042.02	11,221.98	95.06	11,126.92	83.89
E30	Supply Expense							
001-0200-5300	Supplies - Office	500.00	65.63	65.63	434.37	284.53	149.84	29.97
001-0200-5302	Supplies - Kitchen	200.00	0.00	8.34	191.66	0.00	191.66	95.83
001-0200-5306	Supplies - Food Allowance	1,500.00	105.20	185.18	1,314.82	118.92	1,195.90	79.73
001-0200-5322	Supplies - Operating	3,300.00	0.00	43.64	3,256.36	484.31	2,772.05	84.00
001-0200-5350	Postage Expense	100.00	0.00	0.00	100.00	0.00	100.00	100.00
001-0200-5370	Medicine Expense	4,000.00	41.07	227.21	3,772.79	107.96	3,664.83	91.62
001-0200-5371	Spay & Neuter Vouchers	2,000.00	60.00	-285.00	2,285.00	360.00	1,925.00	96.25
E30 Sub Totals:		11,600.00	271.90	245.00	11,355.00	1,355.72	9,999.28	86.20
E40	Operations Expense							
001-0200-5116	Communication Exp - Cellular	3,300.00	263.84	795.20	2,504.80	0.00	2,504.80	75.90
001-0200-5141	Pest/Chem/Seed/Fert	1,000.00	82.13	246.39	753.61	0.00	753.61	75.36
001-0200-5142	Janitorial Supplies	3,000.00	41.49	227.56	2,772.44	26.05	2,746.39	91.55
001-0200-5323	Material and Maint.	200.00	0.00	0.00	200.00	0.00	200.00	100.00
001-0200-5480	Dues & Subscriptions	900.00	52.98	296.03	603.97	0.00	603.97	67.11
001-0200-5593	Animal Care Charges	2,300.00	36.90	36.90	2,263.10	0.00	2,263.10	98.40
001-0200-5608	Computer Software	310.00	0.00	0.00	310.00	0.00	310.00	100.00

Account Number	Description	Budget Amount	Period Amount	YTD Amount	YTD Var	Encumbered Amount	Available	% Available
E40 Sub Totals:		11,010.00	477.34	1,602.08	9,407.92	26.05	9,381.87	85.21
Professional Services								
Marketing Expense		500.00	0.00	0.00	500.00	0.00	500.00	100.00
Prof Services - Advertising		0.00	0.00	0.00	0.00	0.00	0.00	0.00
Prof Services - Incineration & Disp		3,000.00	0.00	32.75	2,967.25	668.39	2,298.86	76.63
Prof Services - Printing		500.00	58.72	128.72	371.28	0.00	371.28	74.26
Prof Services - Veterinarian		14,500.00	980.00	1,133.00	13,367.00	610.00	12,757.00	87.98
E55 Sub Totals:		18,500.00	1,038.72	1,294.47	17,205.53	1,278.39	15,927.14	86.09
Miscellaneous Expensc								
Miscellaneous Expense		100.00	11.60	96.47	3.53	0.00	3.53	3.53
E60 Sub Totals:		100.00	11.60	96.47	3.53	0.00	3.53	3.53
Fixed Assets								
Fixed Assets - A/C		0.00	0.00	0.00	0.00	0.00	0.00	0.00
E80 Sub Totals:		0.00	0.00	0.00	0.00	0.00	0.00	0.00
Expense Sub Totals:		367,902.66	25,580.27	83,131.61	284,771.05	6,212.92	278,558.13	75.72
Dept 0200 Sub Totals:		-51,097.34	-9,230.39	-20,412.57	-30,684.77	6,212.92		
Fines & Forfeitures								
Act 316 of 1991 Revenue		200.00	18.12	54.04	145.96	0.00	145.96	72.98
City Attorney Reim		26,000.00	2,190.68	6,533.30	19,466.70	0.00	19,466.70	74.87
Court Fines		450,000.00	39,882.52	111,933.68	338,066.32	0.00	338,066.32	75.13
District Court Reim		10,000.00	1,181.04	3,522.24	6,477.76	0.00	6,477.76	64.78
Judge Retirement Reim		5,200.00	394.84	1,177.54	4,022.46	0.00	4,022.46	77.36
Ordinance 89-15 Revenue		20,000.00	1,966.60	5,865.03	14,134.97	0.00	14,134.97	70.67
Warrant Fees		40,000.00	6,382.17	18,131.67	21,868.33	0.00	21,868.33	54.67
R40 Sub Totals:		551,400.00	52,015.97	147,217.50	404,182.50	0.00	404,182.50	73.30
Miscellaneous Revenue								
Intoximeter Revenue		550.00	67.14	200.23	349.77	0.00	349.77	63.59
Miscellaneous Revenue		0.00	9.98	33.54	-33.54	0.00	-33.54	0.00
R60 Sub Totals:		550.00	77.12	233.77	316.23	0.00	316.23	57.50
Reimbursement								
Saline County		180,000.00	0.00	42,609.19	137,390.81	0.00	137,390.81	76.33
R64 Sub Totals:		180,000.00	0.00	42,609.19	137,390.81	0.00	137,390.81	76.33

Account Number	Description	Budget Amount	Period Amount	YTD Amount	YTD Var	Encumbered Amount	Available	% Available
E01	Revenue Sub Totals:	731,950.00	52,093.09	190,060.46	541,889.54	0.00	541,889.54	74.03
	Personnel Expense							
001-0300-5000	Salary Expense	211,109.40	15,129.32	51,213.10	159,896.30	0.00	159,896.30	75.74
001-0300-5010	Overtime Expense	500.00	25.07	25.07	474.93	0.00	474.93	94.99
001-0300-5020	FICA Expense	16,188.12	1,143.23	3,868.28	12,319.84	0.00	12,319.84	76.10
001-0300-5022	Unemployment Expense	2,520.00	0.00	0.00	2,520.00	0.00	2,520.00	100.00
001-0300-5025	Worker's Comp Expense	500.00	0.00	493.84	6.16	0.00	6.16	1.23
001-0300-5030	APERS Expense	31,487.08	2,236.80	7,562.78	23,924.30	0.00	23,924.30	75.98
001-0300-5038	Pension Expense-Judge Rtmnt	11,500.00	0.00	0.00	11,500.00	0.00	11,500.00	100.00
001-0300-5040	Health Insurance Expense	35,967.84	3,010.64	9,111.92	26,855.92	0.00	26,855.92	74.67
001-0300-5050	Physical & Drug Screen Exp	750.00	0.00	0.00	750.00	150.00	600.00	80.00
001-0300-5055	Uniform Expense	490.00	0.00	0.00	490.00	0.00	490.00	100.00
001-0300-5060	Travel & Training Expense	9,391.06	0.00	0.00	9,391.06	0.00	9,391.06	100.00
001-0300-5070	Judge - Share to State	30,000.00	2,405.18	7,215.54	22,784.46	7,215.53	15,568.93	51.90
E01 Sub Totals:		350,403.50	23,950.24	79,490.53	270,912.97	7,365.53	263,547.44	75.21
E10	Building & Grounds Exp							
001-0300-5102	Repairs & Maint - Building	10,915.00	57.84	653.92	10,261.08	57.84	10,203.24	93.48
001-0300-5103	Office Equipm/Maintenance	1,000.00	0.00	0.00	1,000.00	0.00	1,000.00	100.00
001-0300-5110	Utilities - Electric	6,130.00	923.58	1,377.28	4,752.72	0.00	4,752.72	77.53
001-0300-5111	Utilities - Gas	1,275.00	185.74	555.83	719.17	0.00	719.17	56.41
001-0300-5112	Utilities - Water	770.00	-20.63	136.65	633.35	0.00	633.35	82.25
001-0300-5115	Communication Exp - Telephone	4,000.00	0.00	857.28	3,142.72	1,174.51	1,968.21	49.21
001-0300-5130	Sanitation	865.00	86.24	258.72	606.28	86.24	520.04	60.12
E10 Sub Totals:		24,955.00	1,232.77	3,839.68	21,115.32	1,318.59	19,796.73	79.33
E30	Supply Expense							
001-0300-5300	Supplies - Office	6,000.00	0.00	166.66	5,833.34	63.84	5,769.50	96.16
001-0300-5350	Postage Expense	1,000.00	0.00	0.00	1,000.00	0.00	1,000.00	100.00
E30 Sub Totals:		7,000.00	0.00	166.66	6,833.34	63.84	6,769.50	96.71
E40	Operations Expense							
001-0300-5142	Janitorial Supplies	650.00	0.00	0.00	650.00	0.00	650.00	100.00
001-0300-5480	Dues & Subscriptions	3,000.00	0.00	963.28	2,036.72	0.00	2,036.72	67.89
001-0300-5608	Computer Software	20,000.00	1,170.00	3,510.00	16,490.00	10,550.00	5,960.00	29.80
E40 Sub Totals:		23,650.00	1,170.00	4,473.28	19,176.72	10,550.00	8,646.72	36.56
E55	Professional Services							
001-0300-5553	Prof Services - Advertising	500.00	0.00	0.00	500.00	0.00	500.00	100.00
001-0300-5589	Prof Services - Printing	3,000.00	0.00	0.00	3,000.00	0.00	3,000.00	100.00
E55 Sub Totals:		3,500.00	0.00	0.00	3,500.00	0.00	3,500.00	100.00

Account Number	Description	Budget Amount	Period Amount	YTD Amount	YTD Var	Encumbered Amount	Available	% Available
E60	Miscellaneous Expense							
001-0300-5606	Computer Maint & Support	500.00	0.00	0.00	500.00	0.00	500.00	100.00
001-0300-5614	Copier Maint & Lease	3,000.00	565.32	777.11	2,222.89	121.12	2,101.77	70.06
	E60 Sub Totals:	3,500.00	565.32	777.11	2,722.89	121.12	2,601.77	74.34
	Expense Sub Totals:	413,008.50	26,918.33	88,747.26	324,261.24	19,399.08	304,862.16	73.81
Dept 0300 Sub Totals:		-318,941.50	-25,174.76	-101,313.20	-217,628.30	19,399.08		
Dept 001-0400	Parks General							
R62	Intergovernmental Tsfrs							
001-0400-4627	Xfer Designated Tax	383,000.00	31,916.66	95,749.98	287,250.02	0.00	287,250.02	75.00
001-0400-4629	Xfer Park 1/8 O & M	480,000.00	40,000.00	120,000.00	360,000.00	0.00	360,000.00	75.00
	R62 Sub Totals:	863,000.00	71,916.66	215,749.98	647,250.02	0.00	647,250.02	75.00
	Revenue Sub Totals:	863,000.00	71,916.66	215,749.98	647,250.02	0.00	647,250.02	75.00
E01	Personnel Expense							
001-0400-5000	Salary Expense	238,602.55	11,307.09	59,780.59	178,821.96	0.00	178,821.96	74.95
001-0400-5001	Park General - Part Time Labor	47,000.00	1,240.03	3,274.01	43,725.99	0.00	43,725.99	93.03
001-0400-5005	SWB Reimbursement	174,400.00	14,533.33	43,599.99	130,800.01	0.00	130,800.01	75.00
001-0400-5010	Overtime Expense	15,000.00	209.04	320.75	14,679.25	0.00	14,679.25	97.86
001-0400-5020	FICA Expense	23,412.00	988.78	4,872.97	18,539.03	0.00	18,539.03	79.19
001-0400-5022	Unemployment Expense	4,445.07	0.00	109.46	4,335.61	0.00	4,335.61	97.54
001-0400-5025	Worker's Comp Expense	7,000.00	0.00	6,929.66	70.34	0.00	70.34	1.00
001-0400-5030	APERS Expense	37,736.06	1,746.54	8,294.25	29,441.81	0.00	29,441.81	78.02
001-0400-5040	Health Insurance Expense	63,463.20	3,114.65	11,154.20	52,309.00	0.00	52,309.00	82.42
001-0400-5050	Physical & Drug Screen Exp	900.00	0.00	0.00	900.00	0.00	900.00	100.00
001-0400-5055	Uniform Expense	4,100.00	0.00	0.00	4,100.00	3,543.00	557.00	13.59
001-0400-5057	Vehicle Allowance	6,000.00	461.54	1,384.62	4,615.38	0.00	4,615.38	76.92
001-0400-5060	Travel & Training Expense	1,300.00	300.00	300.00	1,000.00	200.00	800.00	61.54
	E01 Sub Totals:	623,358.88	33,901.00	140,020.50	483,338.38	3,743.00	479,595.38	76.94
E10	Building & Grounds Exp							
001-0400-5110	Utilities - Electric	2,300.00	198.83	556.83	1,743.17	0.00	1,743.17	75.79
001-0400-5112	Utilities - Water	3,000.00	71.13	651.17	2,348.83	0.00	2,348.83	78.29
001-0400-5120	Insurance - Property	2,000.00	0.00	0.00	2,000.00	0.00	2,000.00	100.00
001-0400-5130	Sanitation	4,500.00	0.00	0.00	4,500.00	0.00	4,500.00	100.00
001-0400-5145	Tools	3,000.00	1,384.61	1,496.73	1,503.27	700.00	803.27	26.78
	E10 Sub Totals:	14,800.00	1,654.57	2,704.73	12,095.27	700.00	11,395.27	77.00
E20	Vehicle Expense							
001-0400-5200	Fuel Expense	25,000.00	1,151.37	2,976.23	22,023.77	0.00	22,023.77	88.10

Account Number	Description	Budget Amount	Period Amount	YTD Amount	YTD Var	Encumbered Amount	Available	% Available
001-0400-5225	Insurance Expense - Vehicle	2,700.00	0.00	2,670.25	29.75	0.00	29.75	1.10
E20 Sub Totals:		27,700.00	1,151.37	5,646.48	22,053.52	0.00	22,053.52	79.62
E30	Supply Expense							
001-0400-5322	Supplies - Operating	55,230.00	5,000.00	5,000.00	50,230.00	36,720.00	13,510.00	24.46
001-0400-5380	Prisoner Care Expense	1,000.00	0.00	0.00	1,000.00	0.00	1,000.00	100.00
E30 Sub Totals:		56,230.00	5,000.00	5,000.00	51,230.00	36,720.00	14,510.00	25.80
E55	Professional Services							
001-0400-5550	Prof Services - Acctg & Audit	5,000.00	0.00	0.00	5,000.00	0.00	5,000.00	100.00
001-0400-5586	Prof Services - Other	25,000.00	5,533.04	5,533.04	19,466.96	0.00	19,466.96	77.87
E55 Sub Totals:		30,000.00	5,533.04	5,533.04	24,466.96	0.00	24,466.96	81.56
E60	Miscellaneous Expense							
001-0400-5608	Computer Software	3,000.00	0.00	69.99	2,930.01	0.00	2,930.01	97.67
E60 Sub Totals:		3,000.00	0.00	69.99	2,930.01	0.00	2,930.01	97.67
E68	Donation Expense							
001-0400-5680	Donation - Boys & Girls Club	0.00	-8,750.00	0.00	0.00	0.00	0.00	0.00
001-0400-5681	Donation - Sr. Adults	0.00	0.00	0.00	0.00	0.00	0.00	0.00
E68 Sub Totals:		0.00	-8,750.00	0.00	0.00	0.00	0.00	0.00
Expense Sub Totals:		755,088.88	38,489.98	158,974.74	596,114.14	41,163.00	554,951.14	73.49
Dept 0400 Sub Totals:		-107,911.12	-33,426.68	-56,775.24	-51,135.88	41,163.00		
Dept 001-0410	Park Program Fees							
R36	Tennis	500.00	0.00	0.00	500.00	0.00	500.00	100.00
001-0410-4384		500.00	0.00	0.00	500.00	0.00	500.00	100.00
R36 Sub Totals:		500.00	0.00	0.00	500.00	0.00	500.00	100.00
R50	Sale of Services							
001-0410-4500	Mills Pool-Admin/Concessions	40,000.00	450.00	600.00	39,400.00	0.00	39,400.00	98.50
001-0410-4534	Pavillion Fees	4,500.00	1,310.00	1,455.00	3,045.00	0.00	3,045.00	67.67
R50 Sub Totals:		44,500.00	1,760.00	2,055.00	42,445.00	0.00	42,445.00	95.38
Revenue Sub Totals:		45,000.00	1,760.00	2,055.00	42,945.00	0.00	42,945.00	95.43
E01	Personnel Expense							
001-0410-5020	FICA Expense	1,912.60	0.00	0.00	1,912.60	0.00	1,912.60	100.00
001-0410-5022	Unemployment Expense	750.00	0.00	0.00	750.00	0.00	750.00	100.00
001-0410-5025	Worker's Comp Expense	500.00	0.00	483.46	16.54	0.00	16.54	3.31

Account Number	Description	Budget Amount	Period Amount	YTD Amount	YTD Var	Encumbered Amount	Available	% Available
001-0410-5050	Physical & Drug Screen Exp	2,550.00	0.00	0.00	2,550.00	0.00	2,550.00	100.00
E01 Sub Totals:		5,712.60	0.00	483.46	5,229.14	0.00	5,229.14	91.54
E10	Building & Grounds Exp							
001-0410-5001	Park Mills - Part Time Labor	25,000.00	0.00	0.00	25,000.00	0.00	25,000.00	100.00
001-0410-5102	Repairs & Maint - Building	1,000.00	0.00	0.00	1,000.00	0.00	1,000.00	100.00
001-0410-5104	Repairs & Maint - Grounds	9,198.00	0.00	0.00	9,198.00	0.00	9,198.00	100.00
001-0410-5105	Repairs & Maint - Pool	0.00	0.00	0.00	0.00	0.00	0.00	0.00
001-0410-5110	Utilities - Electric	4,500.00	596.93	1,167.15	3,332.85	0.00	3,332.85	74.06
001-0410-5112	Utilities - Water	1,500.00	48.47	155.83	1,344.17	0.00	1,344.17	89.61
001-0410-5120	Insurance - Property	750.00	0.00	0.00	750.00	0.00	750.00	100.00
001-0410-5130	Sanitation	3,500.00	506.90	1,281.81	2,218.19	342.64	1,875.55	53.59
E10 Sub Totals:		45,448.00	1,152.30	2,604.79	42,843.21	342.64	42,500.57	93.51
E30	Supply Expense							
001-0410-5308	Supplies - Concession	2,500.00	0.00	0.00	2,500.00	0.00	2,500.00	100.00
001-0410-5328	Supplies - Pools	3,500.00	0.00	0.00	3,500.00	0.00	3,500.00	100.00
E30 Sub Totals:		6,000.00	0.00	0.00	6,000.00	0.00	6,000.00	100.00
Expense Sub Totals:		57,160.60	1,152.30	3,088.25	54,072.35	342.64	53,729.71	94.00
Dept 0410 Sub Totals:		12,160.60	-607.70	1,033.25	11,127.35	342.64		
E10	Building & Grounds Exp							
001-0420-5104	Building & Grounds Exp	0.00	0.00	0.00	0.00	0.00	0.00	0.00
E10 Sub Totals:		0.00	0.00	0.00	0.00	0.00	0.00	0.00
Expense Sub Totals:		0.00	0.00	0.00	0.00	0.00	0.00	0.00
Dept 0420 Sub Totals:		0.00	0.00	0.00	0.00	0.00		
R30	Membership Fees							
001-0430-4300	Membership Family	224,000.00	17,379.42	48,966.26	175,033.74	0.00	175,033.74	78.14
001-0430-4301	Membership Senior	80,000.00	8,240.00	24,560.00	55,440.00	0.00	55,440.00	69.30
001-0430-4302	Membership Adults	60,000.00	4,645.00	13,700.00	46,300.00	0.00	46,300.00	77.17
001-0430-4303	Membership Youth	20,000.00	1,920.00	5,770.00	14,230.00	0.00	14,230.00	71.15
001-0430-4304	Membership Silver Sneakers	40,000.00	9,159.50	16,638.50	23,361.50	0.00	23,361.50	58.40
001-0430-4310	Membership 3 Mo Adult	550.00	50.00	50.00	500.00	0.00	500.00	90.91
001-0430-4311	Membership 3 Mo Youth	7,000.00	735.00	1,890.00	5,110.00	0.00	5,110.00	73.00
001-0430-4312	Membership 3 Mo Senior	8,500.00	720.00	2,970.00	5,530.00	0.00	5,530.00	65.06
001-0430-4313	Membership 3 Mo Family	14,000.00	950.00	3,885.00	10,115.00	0.00	10,115.00	72.25

Account Number	Description	Budget Amount	Period Amount	YTD Amount	YTD Var	Encumbered Amount	Available	% Available
001-0430-4314	Membership 3 Mo College	2,000.00	0.00	0.00	2,000.00	0.00	2,000.00	100.00
001-0430-4318	Membership 6 Mo College	3,000.00	0.00	0.00	3,000.00	0.00	3,000.00	100.00
001-0430-4319	Membership 6 Mo Military	2,400.00	0.00	0.00	2,400.00	0.00	2,400.00	100.00
001-0430-4320	Membership Annual Adult	5,000.00	1,144.54	3,103.62	1,896.38	0.00	1,896.38	37.93
001-0430-4321	Membership Annual Youth	6,500.00	610.00	1,590.00	4,910.00	0.00	4,910.00	75.54
001-0430-4322	Membership Annual Senior	45,000.00	4,080.00	14,200.00	30,800.00	0.00	30,800.00	68.44
001-0430-4323	Membership Annual Family	25,000.00	4,032.00	6,864.00	18,136.00	0.00	18,136.00	72.54
001-0430-4384	Spec Prgrms-Tennis Youth	3,000.00	695.00	1,045.00	1,955.00	0.00	1,955.00	65.17
	R30 Sub Totals:	545,950.00	54,360.46	145,232.38	400,717.62	0.00	400,717.62	73.40
R33	Rental Fees							
001-0430-4332	Equipment Rental	3,000.00	515.00	735.00	2,265.00	0.00	2,265.00	75.50
001-0430-4334	After Hours Charge Bishop	1,000.00	15.00	150.00	850.00	0.00	850.00	85.00
001-0430-4336	Room Rental Large Room (both)	8,000.00	1,870.00	4,420.00	3,580.00	0.00	3,580.00	44.75
001-0430-4337	Room Rental Large Room	15,000.00	1,355.00	3,795.00	11,205.00	0.00	11,205.00	74.70
001-0430-4338	Room Rental Small Rooms (both)	3,000.00	210.00	895.00	2,105.00	0.00	2,105.00	70.17
001-0430-4339	Room Rental Small Room	5,200.00	570.00	1,720.00	3,480.00	0.00	3,480.00	66.92
001-0430-4340	Room Rental Party Room	30,000.00	2,760.00	8,160.00	21,840.00	0.00	21,840.00	72.80
001-0430-4341	Room Rental Court Gym	7,000.00	575.00	2,050.00	4,950.00	0.00	4,950.00	70.71
001-0430-4342	Room Rental Full Gym	2,000.00	0.00	2,050.00	-50.00	0.00	-50.00	0.00
001-0430-4343	Room Rental Full Facility	2,000.00	0.00	0.00	2,000.00	0.00	2,000.00	100.00
001-0430-4344	Room Rental Fitness Room	1,000.00	320.00	690.00	310.00	0.00	310.00	31.00
001-0430-4345	Rental - Splash Pad	6,500.00	0.00	0.00	6,500.00	0.00	6,500.00	100.00
001-0430-4347	Competitive Pool Fees	10,000.00	0.00	1,275.00	8,725.00	0.00	8,725.00	87.25
001-0430-4348	Therapy Pool Fees	1,000.00	0.00	0.00	1,000.00	0.00	1,000.00	100.00
001-0430-4350	Use Agreement Fees	3,500.00	0.00	0.00	3,500.00	0.00	3,500.00	100.00
001-0430-4352	Rental - Outdoor Field Fees	0.00	37.50	37.50	-37.50	0.00	-37.50	0.00
001-0430-4354	Tournaments	40,000.00	1,250.00	2,660.00	37,340.00	0.00	37,340.00	93.35
	R33 Sub Totals:	138,200.00	9,477.50	28,637.50	109,562.50	0.00	109,562.50	79.28
R36	Park Program Fees							
001-0430-4364	Basketball	30,000.00	502.00	13,360.00	16,640.00	0.00	16,640.00	55.47
001-0430-4366	BASS Swim Program	32,500.00	4,820.00	12,330.75	20,169.25	0.00	20,169.25	62.06
001-0430-4370	Flag Football	5,000.00	0.00	0.00	5,000.00	0.00	5,000.00	100.00
001-0430-4374	Life Coach Class	0.00	938.75	2,682.06	-2,682.06	0.00	-2,682.06	0.00
001-0430-4376	Programs - Misc Activity	1,000.00	0.00	0.00	1,000.00	0.00	1,000.00	100.00
001-0430-4382	Pool Swim Lessons	55,000.00	6,892.00	15,762.00	39,238.00	0.00	39,238.00	71.34
001-0430-4386	Track	1,500.00	0.00	0.00	1,500.00	0.00	1,500.00	100.00
001-0430-4390	Volleyball Adult/Youth	10,000.00	0.00	825.00	9,175.00	0.00	9,175.00	91.75
	R36 Sub Totals:	135,000.00	13,152.75	44,959.81	90,040.19	0.00	90,040.19	66.70
R50	Sale of Services							
001-0430-4500	Concessions - Bishop	30,000.00	4,713.61	23,769.35	6,230.65	0.00	6,230.65	20.77
001-0430-4514	Daily Admissions Adults	28,000.00	2,898.00	6,642.00	21,358.00	0.00	21,358.00	76.28

Account Number	Description	Budget Amount	Period Amount	YTD Amount	YTD Var	Encumbered Amount	Available	% Available
001-0430-4516	Daily Admissions Senior	1,500.00	104.00	293.00	1,207.00	0.00	1,207.00	80.47
001-0430-4518	Daily Admissions Youth	25,000.00	2,660.00	4,856.00	20,144.00	0.00	20,144.00	80.58
001-0430-4520	Multiple Adults	7,500.00	450.00	1,845.00	5,655.00	0.00	5,655.00	75.40
001-0430-4522	Multiple Senior	1,300.00	150.00	420.00	880.00	0.00	880.00	67.69
001-0430-4524	Multiple Youth	2,500.00	180.00	390.00	2,110.00	0.00	2,110.00	84.40
001-0430-4530	Merchandise Sales	3,500.00	127.00	257.00	3,243.00	0.00	3,243.00	92.66
001-0430-4532	Spectator Admissions	6,000.00	0.00	0.00	6,000.00	0.00	6,000.00	100.00
001-0430-4534	Red Cross Programs	5,000.00	630.00	1,635.00	3,365.00	0.00	3,365.00	67.30
	R50 Sub Totals:	110,300.00	11,912.61	40,107.35	70,192.65	0.00	70,192.65	63.64
R60	Miscellaneous Revenue							
001-0430-4600	Miscellaneous Revenue	1,000.00	0.00	0.00	1,000.00	0.00	1,000.00	100.00
	R60 Sub Totals:	1,000.00	0.00	0.00	1,000.00	0.00	1,000.00	100.00
R70	Grant Revenue							
001-0430-4702	Grant - Veterans	50,000.00	0.00	0.00	50,000.00	0.00	50,000.00	100.00
	R70 Sub Totals:	50,000.00	0.00	0.00	50,000.00	0.00	50,000.00	100.00
R74	Sponsorships							
001-0430-4740	Sponsorship/Rebates	10,000.00	1,200.00	1,500.00	8,500.00	0.00	8,500.00	85.00
001-0430-4742	Scoreboard Signage BP	110,000.00	1,667.00	7,167.68	102,832.32	0.00	102,832.32	93.48
	R74 Sub Totals:	120,000.00	2,867.00	8,667.68	111,332.32	0.00	111,332.32	92.78
	Revenue Sub Totals:	1,100,450.00	91,770.32	267,604.72	832,845.28	0.00	832,845.28	75.68
E01	Personnel Expense							
001-0430-5000	Salary Expense	304,348.19	20,225.50	69,274.84	235,073.35	0.00	235,073.35	77.24
001-0430-5001	Park Bishop - Part Time Labor	45,000.00	7,967.89	25,394.43	19,605.57	0.00	19,605.57	43.57
001-0430-5010	Overtime Expense	5,000.00	0.00	1,543.73	3,456.27	0.00	3,456.27	69.13
001-0430-5020	FICA Expense	34,022.68	2,125.04	7,262.52	26,760.16	0.00	26,760.16	78.65
001-0430-5022	Unemployment Expense	10,464.14	0.00	689.66	9,774.48	0.00	9,774.48	93.41
001-0430-5025	Worker's Comp Expense	9,000.00	0.00	8,702.36	297.64	0.00	297.64	3.31
001-0430-5030	APERS Expense	39,335.00	2,985.27	10,452.83	28,882.17	0.00	28,882.17	73.43
001-0430-5040	Health Insurance Expense	58,987.20	4,118.28	12,430.84	46,556.36	0.00	46,556.36	78.93
001-0430-5050	Physical & Drug Screen Exp	1,500.00	150.00	450.00	1,050.00	175.00	875.00	58.33
001-0430-5055	Uniform Expense	3,000.00	0.00	0.00	3,000.00	0.00	3,000.00	100.00
	E01 Sub Totals:	510,657.21	37,571.98	136,201.21	374,456.00	175.00	374,281.00	73.29
E10	Building & Grounds Exp							
001-0430-5102	Repairs & Maint - Building	19,500.00	1,102.37	5,596.51	13,903.49	4,849.03	9,054.46	46.43
001-0430-5104	Repairs & Maint - Grounds	37,400.00	21,227.48	27,283.74	10,116.26	8,450.79	1,665.47	4.45
001-0430-5105	Repairs & Maint - Pool	45,000.00	3,768.85	9,846.31	35,153.69	2,976.36	32,177.33	71.51
001-0430-5106	Repairs & Maint - Splash Pad	2,492.00	0.00	0.00	2,492.00	0.00	2,492.00	100.00

Account Number	Description	Budget Amount	Period Amount	YTD Amount	YTD Var	Encumbered Amount	Available	% Available
001-0430-5110	Utilities - Electric	185,000.00	13,711.37	42,965.29	142,034.71	0.00	142,034.71	76.78
001-0430-5111	Utilities - Gas	48,000.00	7,729.52	13,283.48	34,716.52	0.00	34,716.52	72.33
001-0430-5112	Utilities - Water	18,000.00	862.12	2,658.13	15,341.87	0.00	15,341.87	85.23
001-0430-5115	Communication Exp - Telephone	16,000.00	1,030.79	3,701.62	12,298.38	0.00	12,298.38	76.86
001-0430-5116	Communication Exp - Cellular	10,200.00	454.49	1,362.84	8,837.16	0.00	8,837.16	86.64
001-0430-5120	Insurance - Property	35,000.00	0.00	0.00	35,000.00	0.00	35,000.00	100.00
001-0430-5130	Sanitation	18,000.00	1,029.70	3,865.83	14,134.17	0.00	14,134.17	78.52
001-0430-5140	Supplies - B&G	2,000.00	7.77	35.89	1,964.11	336.71	1,627.40	81.37
E10 Sub Totals:		436,592.00	50,924.46	110,599.64	325,992.36	16,612.89	309,379.47	70.86
E20	Vehicle Expense							
001-0430-5212	Service & Repair - Equipment	5,000.00	94.85	94.85	4,905.15	355.34	4,549.81	91.00
E20 Sub Totals:		5,000.00	94.85	94.85	4,905.15	355.34	4,549.81	91.00
E30	Supply Expense							
001-0430-5300	Supplies - Office	1,000.00	0.00	571.29	428.71	415.00	13.71	1.37
001-0430-5308	Supplies - Concession	32,500.00	4,493.17	13,407.16	19,092.84	1,211.31	17,881.53	55.02
001-0430-5330	Supplies - Park Programs	6,000.00	1,651.12	2,341.44	3,658.56	345.06	3,313.50	55.23
001-0430-5332	Supplies - Resale Merchandise	2,500.00	0.00	1,506.54	993.46	0.00	993.46	39.74
E30 Sub Totals:		42,000.00	6,144.29	17,826.43	24,173.57	1,971.37	22,202.20	52.86
E40	Operations Expense							
001-0430-5141	Pest/Chem/Seed/Fert-Bishop	2,000.00	328.50	945.60	1,054.40	0.00	1,054.40	52.72
001-0430-5142	Janitorial Supplies	20,000.00	1,155.40	8,492.63	11,507.37	657.46	10,849.91	54.25
001-0430-5214	Equipment-Bishop	30,000.00	0.00	0.00	30,000.00	13,484.92	16,515.08	55.05
001-0430-5460	BASS Program Expense	10,000.00	380.00	3,398.95	6,601.05	900.53	5,700.52	57.01
001-0430-5461	Aquatic Program Expense	2,500.00	0.00	570.98	1,929.02	0.00	1,929.02	77.16
001-0430-5475	Credit Card Fees	35,000.00	3,922.18	8,127.75	26,872.25	0.00	26,872.25	76.78
001-0430-5480	Dues & Subscriptions	500.00	0.00	0.00	500.00	0.00	500.00	100.00
E40 Sub Totals:		100,000.00	5,786.08	21,535.91	78,464.09	15,042.91	63,421.18	63.42
E55	Professional Services							
001-0430-5553	Prof Services - Advertising	3,000.00	0.00	647.95	2,352.05	487.20	1,864.85	62.16
001-0430-5585	Prof Service - Basketball	0.00	0.00	0.00	0.00	0.00	0.00	0.00
001-0430-5586	Prof Services - Other	90,000.00	9,854.25	40,671.73	49,328.27	1,180.00	48,148.27	53.50
001-0430-5587	Prof Services - Aerobic Instr	0.00	0.00	0.00	0.00	0.00	0.00	0.00
001-0430-5589	Prof Services - Printing	3,000.00	85.00	373.22	2,626.78	0.00	2,626.78	87.56
E55 Sub Totals:		96,000.00	9,939.25	41,692.90	54,307.10	1,667.20	52,639.90	54.83
E60	Miscellaneous Expense							
001-0430-5485	Inspections & Monitoring	6,500.00	629.23	1,391.07	5,108.93	0.00	5,108.93	78.60
001-0430-5608	Computer Software	11,200.00	69.99	69.99	11,130.01	0.00	11,130.01	99.38

Account Number	Description	Budget Amount	Period Amount	YTD Amount	YTD Var	Encumbered Amount	Available	% Available
E70	E60 Sub Totals:	17,700.00	699.22	1,461.06	16,238.94	0.00	16,238.94	91.75
	Grant Expense							
001-0430-5700	Grant Expense	115,000.00	12,028.58	12,028.58	102,971.42	0.00	102,971.42	89.54
	E70 Sub Totals:	115,000.00	12,028.58	12,028.58	102,971.42	0.00	102,971.42	89.54
E80	Fixed Assets							
001-0430-5810	Fixed Assets - Equip/Imp.	85,000.00	0.00	0.00	85,000.00	0.00	85,000.00	100.00
001-0430-5813	Fixed Assets - Scoreboard	85,000.00	0.00	0.00	85,000.00	0.00	85,000.00	100.00
	E80 Sub Totals:	170,000.00	0.00	0.00	170,000.00	0.00	170,000.00	100.00
E85	Interest Expense							
001-0430-5850	Interest Expense	4,000.00	0.00	0.00	4,000.00	0.00	4,000.00	100.00
	E85 Sub Totals:	4,000.00	0.00	0.00	4,000.00	0.00	4,000.00	100.00
	Expense Sub Totals:	1,496,949.21	123,188.71	341,440.58	1,155,508.63	35,824.71	1,119,683.92	74.80
	Dept 0430 Sub Totals:	396,499.21	31,418.39	73,835.86	322,663.35	35,824.71		
Dept 001-0500	Fire Department							
R15	Taxes - Property							
001-0500-4156	Fire Rescue Funds	0.00	286.59	313.20	-313.20	0.00	-313.20	0.00
	R15 Sub Totals:	0.00	286.59	313.20	-313.20	0.00	-313.20	0.00
R62	Intergovernmental Tsfrs							
001-0500-4627	Xfer Designated Tax	960,000.00	80,000.00	240,000.00	720,000.00	0.00	720,000.00	75.00
001-0500-4629	Xfer Fire Special Tax	1,440,000.00	105,416.66	316,249.98	1,123,750.02	0.00	1,123,750.02	78.04
	R62 Sub Totals:	2,400,000.00	185,416.66	556,249.98	1,843,750.02	0.00	1,843,750.02	76.82
	Revenue Sub Totals:	2,400,000.00	185,703.25	556,563.18	1,843,436.82	0.00	1,843,436.82	76.81
E01	Personnel Expense							
001-0500-5000	Salary Expense	2,025,576.26	141,965.56	531,668.99	1,493,907.27	0.00	1,493,907.27	73.75
001-0500-5010	Overtime Expense	184,000.00	8,980.05	29,475.93	154,524.07	0.00	154,524.07	83.98
001-0500-5020	FICA Expense	34,140.60	2,305.76	8,482.68	25,657.92	0.00	25,657.92	75.15
001-0500-5022	Unemployment Expense	17,640.00	0.00	425.86	17,214.14	0.00	17,214.14	97.59
001-0500-5025	Worker's Comp Expense	79,000.00	0.00	78,378.08	621.92	0.00	621.92	0.79
001-0500-5030	APERS Expense	5,163.36	395.60	1,357.82	3,805.54	0.00	3,805.54	73.70
001-0500-5035	LOPFI Expense	442,324.62	29,992.95	81,877.70	360,446.92	0.00	360,446.92	81.49
001-0500-5036	LOPFI Perm Advance	-150,000.00	0.00	0.00	-150,000.00	0.00	-150,000.00	0.00
001-0500-5040	Health Insurance Expense	377,102.40	30,482.16	93,263.64	283,838.76	0.00	283,838.76	75.27
001-0500-5050	Physical & Drug Screen Exp	13,750.00	886.58	1,560.58	12,189.42	0.00	12,189.42	88.65
001-0500-5055	Uniform Expense	16,000.00	432.50	1,183.59	14,816.41	261.02	14,555.39	90.97

Account Number	Description	Budget Amount	Period Amount	YTD Amount	YTD Var	Encumbered Amount	Available	% Available
001-0500-5060	Travel & Training Expense	8,500.00	0.00	-1,174.66	9,674.66	93.90	9,580.76	112.71
E01 Sub Totals:		3,053,197.24	215,441.16	826,500.21	2,226,697.03	354.92	2,226,342.11	72.92
E10	Building & Grounds Exp							
001-0500-5102	Repairs & Maint - Building	17,400.00	1,177.63	7,832.72	9,567.28	34.02	9,533.26	54.79
001-0500-5110	Utilities - Electric	37,000.00	2,891.14	8,371.83	28,628.17	0.00	28,628.17	77.37
001-0500-5111	Utilities - Gas	6,000.00	753.93	2,201.70	3,798.30	545.03	3,253.27	54.22
001-0500-5112	Utilities - Water	6,500.00	395.89	1,315.89	5,184.11	0.00	5,184.11	79.76
001-0500-5115	Communication Exp - Telephone	21,000.00	2,968.47	5,254.85	15,745.15	0.00	15,745.15	74.98
001-0500-5116	Communication Exp - Cellular	4,000.00	223.84	683.20	3,316.80	0.00	3,316.80	82.92
001-0500-5120	Insurance - Property	10,500.00	0.00	0.00	10,500.00	0.00	10,500.00	100.00
001-0500-5130	Sanitation	1,500.00	122.10	122.10	1,377.90	0.00	1,377.90	91.86
001-0500-5145	Tools	1,200.00	248.03	282.68	917.32	0.00	917.32	76.44
E10 Sub Totals:		105,100.00	8,781.03	26,064.97	79,035.03	579.05	78,455.98	74.65
E20	Vehicle Expense							
001-0500-5200	Fuel Expense	48,000.00	1,939.67	6,503.71	41,496.29	0.00	41,496.29	86.45
001-0500-5212	Service & Repair - Equipment	3,000.00	0.00	0.00	3,000.00	7.62	2,992.38	99.75
001-0500-5215	R & M Vehicle	2,400.00	12.30	12.30	2,387.70	0.00	2,387.70	99.49
001-0500-5216	Service & Repair - Apparatus	22,000.00	-13,252.93	-11,719.30	33,719.30	537.78	33,181.52	150.83
001-0500-5225	Insurance Expense - Vehicle	27,000.00	-178.82	19,755.68	7,244.32	13.00	7,231.32	26.78
001-0500-5230	Radios	6,000.00	0.00	389.82	5,610.18	0.00	5,610.18	93.50
E20 Sub Totals:		108,400.00	-11,479.78	14,942.21	93,457.79	558.40	92,899.39	85.70
E30	Supply Expense							
001-0500-5141	Pest/Chem/Seed/Fert-Fire	1,200.00	151.11	151.11	1,048.89	96.32	952.57	79.38
001-0500-5142	Janitorial Supplies-Fire	11,000.00	910.69	2,182.46	8,817.54	263.19	8,554.35	77.77
001-0500-5300	Supplies - Office	3,000.00	0.00	17.49	2,982.51	69.48	2,913.03	97.10
001-0500-5302	Supplies - Kitchen	1,200.00	0.00	3.10	1,196.90	22.64	1,174.26	97.86
001-0500-5304	Supplies - Extinguisher	500.00	0.00	0.00	500.00	0.00	500.00	100.00
001-0500-5306	Supplies - Food Allowance	43,800.00	3,253.44	6,381.25	37,418.75	3,383.66	34,035.09	77.71
001-0500-5318	Supplies - Foam	1,500.00	0.00	0.00	1,500.00	0.00	1,500.00	100.00
001-0500-5320	Supplies - Hazardous Mat'l	2,000.00	175.75	267.85	1,732.15	4.16	1,727.99	86.40
001-0500-5350	Postage Expense	500.00	0.00	0.00	500.00	1.40	498.60	99.72
E30 Sub Totals:		64,700.00	4,490.99	9,003.26	55,696.74	3,840.85	51,855.89	80.15
E40	Operations Expense							
001-0500-5061	Training Aids-Fire	9,550.00	128.04	128.04	9,421.96	0.00	9,421.96	98.66
001-0500-5217	Equipment Repair - Fire	3,000.00	0.00	0.00	3,000.00	0.00	3,000.00	100.00
001-0500-5218	Pager Purchase/Repair - Fire	3,000.00	0.00	0.00	3,000.00	0.00	3,000.00	100.00
001-0500-5323	Material and Maint. Fire	1,600.00	332.00	332.00	1,268.00	22.94	1,245.06	77.82
001-0500-5480	Dues & Subscriptions	1,500.00	320.00	320.00	1,180.00	0.00	1,180.00	78.67
001-0500-5530	Safety Program	10,000.00	0.00	0.00	10,000.00	0.00	10,000.00	100.00

Account Number	Description	Budget Amount	Period Amount	YTD Amount	YTD Var	Encumbered Amount	Available	% Available
E55	E40 Sub Totals:	28,650.00	780.04	780.04	27,869.96	22.94	27,847.02	97.20
	Professional Services							
001-0500-5553	Prof Services - Advertising	1,000.00	0.00	0.00	1,000.00	0.00	1,000.00	100.00
001-0500-5586	Prof Services - Other	1,500.00	0.00	0.00	1,500.00	0.00	1,500.00	100.00
001-0500-5589	Prof Services - Printing	1,000.00	30.00	90.00	910.00	0.00	910.00	91.00
	E55 Sub Totals:	3,500.00	30.00	90.00	3,410.00	0.00	3,410.00	97.43
E60	Miscellaneous Expense							
001-0500-5606	Computer Maint & Support	3,500.00	2,700.00	2,700.00	800.00	0.00	800.00	22.86
	E60 Sub Totals:	3,500.00	2,700.00	2,700.00	800.00	0.00	800.00	22.86
E70	Grant Expense							
001-0500-5700	Grant Expense	212.23	0.00	0.00	212.23	0.00	212.23	100.00
	E70 Sub Totals:	212.23	0.00	0.00	212.23	0.00	212.23	100.00
E80	Fixed Assets							
001-0500-5808	Fixed Assets - Vehicles	0.00	-14,657.84	0.00	0.00	0.00	0.00	0.00
001-0500-5830	Springhill Fire Department	50,000.00	821.25	821.25	49,178.75	0.00	49,178.75	98.36
	E80 Sub Totals:	50,000.00	-13,836.59	821.25	49,178.75	0.00	49,178.75	98.36
	Expense Sub Totals:	3,417,259.47	206,906.85	880,901.94	2,536,357.53	5,356.16	2,531,001.37	74.07
Dept 001-0510	Dept 0500 Sub Totals:	1,017,259.47	21,203.60	324,338.76	692,920.71	5,356.16		
R15	Taxes - Property							
001-0510-4152	Springhill VFD Assessment	50,000.00	1,879.00	1,879.00	48,121.00	0.00	48,121.00	96.24
	R15 Sub Totals:	50,000.00	1,879.00	1,879.00	48,121.00	0.00	48,121.00	96.24
E40	Revenue Sub Totals:	50,000.00	1,879.00	1,879.00	48,121.00	0.00	48,121.00	96.24
001-0510-5800	Operations Expense	0.00	0.00	0.00	0.00	0.00	0.00	0.00
	Springhill VFD - Expense	0.00	0.00	0.00	0.00	0.00	0.00	0.00
	E40 Sub Totals:	0.00	0.00	0.00	0.00	0.00	0.00	0.00
	Expense Sub Totals:	0.00	0.00	0.00	0.00	0.00	0.00	0.00
Dept R40	Dept 0510 Sub Totals:	-50,000.00	-1,879.00	-1,879.00	-48,121.00	0.00		
	Police							
	Fines & Forfeitures							

Account Number	Description	Budget Amount	Period Amount	YTD Amount	YTD Var	Encumbered Amount	Available	% Available
001-0600-4422	Intoximeter Revenue	700.00	0.00	0.00	700.00	0.00	700.00	100.00
R40 Sub Totals:		700.00	0.00	0.00	700.00	0.00	700.00	100.00
R62	Intergovernmental Tsfrs							
001-0600-4627	Xfer Designated Tax	960,000.00	80,000.00	240,000.00	720,000.00	0.00	720,000.00	75.00
R62 Sub Totals:		960,000.00	80,000.00	240,000.00	720,000.00	0.00	720,000.00	75.00
R70	Grant Revenue							
001-0600-4700	Grant - Police DUJ/Step	25,000.00	0.00	0.00	25,000.00	0.00	25,000.00	100.00
001-0600-4702	Grant - Body Armor	9,000.00	0.00	0.00	9,000.00	0.00	9,000.00	100.00
001-0600-4704	Grant - JAG Equip	6,700.00	0.00	0.00	6,700.00	0.00	6,700.00	100.00
R70 Sub Totals:		40,700.00	0.00	0.00	40,700.00	0.00	40,700.00	100.00
Revenue Sub Totals:		1,001,400.00	80,000.00	240,000.00	761,400.00	0.00	761,400.00	76.03
E01	Personnel Expense							
001-0600-5000	Salary Expense	1,551,133.34	115,137.54	436,977.93	1,114,155.41	0.00	1,114,155.41	71.83
001-0600-5010	Overtime Expense	65,000.00	4,777.37	10,718.46	54,281.54	0.00	54,281.54	83.51
001-0600-5020	FICA Expense	123,414.02	9,040.16	33,848.61	89,565.41	0.00	89,565.41	72.57
001-0600-5022	Unemployment Expense	12,960.00	0.00	0.00	12,960.00	0.00	12,960.00	100.00
001-0600-5025	Worker's Comp Expense	26,000.00	0.00	24,389.62	1,610.38	0.00	1,610.38	6.19
001-0600-5030	APERS Expense	24,535.61	1,927.98	6,965.51	17,570.10	0.00	17,570.10	71.61
001-0600-5035	LOPFI Expense	320,879.11	23,759.85	62,160.59	258,718.52	0.00	258,718.52	80.63
001-0600-5036	LOPFI Prem Advance	-135,000.00	0.00	0.00	-135,000.00	0.00	-135,000.00	0.00
001-0600-5040	Health Insurance Expense	281,667.84	23,464.34	70,858.52	210,809.32	0.00	210,809.32	74.84
001-0600-5050	Physical & Drug Screen Exp	3,000.00	0.00	175.00	2,825.00	0.00	2,825.00	94.17
001-0600-5055	Uniform Expense - Cleaning	14,000.00	2,048.22	2,259.12	11,740.88	1,230.07	10,510.81	75.08
001-0600-5056	Uniform Expense - New Officer	15,120.00	1,020.00	3,060.00	12,060.00	0.00	12,060.00	79.76
001-0600-5057	Uniform Expense - Training Expense	15,000.00	0.00	0.00	15,000.00	0.00	15,000.00	100.00
001-0600-5060	Travel & Training Expense	23,000.00	3,077.70	4,896.70	18,103.30	1,620.81	16,482.49	71.66
001-0600-5065	First Aid Expense	500.00	0.00	0.00	500.00	0.00	500.00	100.00
001-0600-5705	Grant Expense - DUI/Step	25,000.00	0.00	503.12	24,496.88	0.00	24,496.88	97.99
E01 Sub Totals:		2,366,209.92	184,253.16	656,813.18	1,709,396.74	2,850.88	1,706,545.86	72.12
E10	Building & Grounds Exp							
001-0600-5102	Repairs & Maint - Building	0.00	0.00	299.18	-299.18	0.00	-299.18	0.00
001-0600-5110	Utilities - Electric	14,000.00	1,006.99	2,921.82	11,078.18	0.00	11,078.18	79.13
001-0600-5111	Utilities - Gas	1,250.00	145.56	389.60	860.40	229.07	631.33	50.51
001-0600-5112	Utilities - Water	2,700.00	151.49	336.31	2,363.69	0.00	2,363.69	87.54
001-0600-5115	Communication Exp - Telephone	45,000.00	4,784.26	9,154.18	35,845.82	907.68	34,938.14	77.64
001-0600-5120	Insurance - Property	4,500.00	-26,708.68	-26,708.68	31,208.68	0.00	31,208.68	693.53
001-0600-5130	Sanitation	1,900.00	201.39	523.01	1,376.99	160.81	1,216.18	64.01

Account Number	Description	Budget Amount	Period Amount	YTD Amount	YTD Var	Encumbered Amount	Available	% Available
E10	E10 Sub Totals:	69,350.00	-20,418.99	-13,084.58	82,434.58	1,297.56	81,137.02	117.00
	Vehicle Expense							
	Fuel Expense	175,000.00	9,276.59	24,646.61	150,353.39	0.00	150,353.39	85.92
	Service & Repair - Vehicle	20,000.00	3,934.12	12,770.71	7,229.29	1,206.00	6,023.29	30.12
	Vehicle Expense - Car Wash	200.00	0.00	0.00	200.00	0.00	200.00	100.00
	Equipment - CID - Police	2,400.00	113.50	423.75	1,976.25	0.00	1,976.25	82.34
	Tire Expense	15,000.00	0.00	0.00	15,000.00	0.00	15,000.00	100.00
	Insurance Expense - Vehicle	40,000.00	-21,450.59	-4,724.30	44,724.30	0.00	44,724.30	111.81
	Narcotics Rental	6,100.00	0.00	0.00	6,100.00	0.00	6,100.00	100.00
E20	E20 Sub Totals:	258,700.00	-8,126.38	33,116.77	225,583.23	1,206.00	224,377.23	86.73
E30	Supply Expense							
	Supplies - Office	5,000.00	714.98	1,284.60	3,715.40	413.13	3,302.27	66.05
	Supplies - Weapons	3,000.00	0.00	0.00	3,000.00	0.00	3,000.00	100.00
	Supplies - Ammunition	18,000.00	6,174.92	6,174.92	11,825.08	0.00	11,825.08	65.69
	Supplies - Raid Vests	13,000.00	0.00	0.00	13,000.00	11,908.13	1,091.87	8.40
	Postage Expense	750.00	75.13	122.13	627.87	0.00	627.87	83.72
	Prisoner Care Expense	1,000.00	0.00	0.00	1,000.00	0.00	1,000.00	100.00
E30	E30 Sub Totals:	40,750.00	6,965.03	7,581.65	33,168.35	12,321.26	20,847.09	51.16
E40	Operations Expense							
	Training Aids-Police	3,000.00	39.61	103.70	2,896.30	0.00	2,896.30	96.54
	Communication Exp - Cellular	28,000.00	1,887.20	6,033.39	21,966.61	1,841.58	20,125.03	71.88
	Pest/Chem/Seed/Fert. Exp	0.00	0.00	36.20	-36.20	0.00	-36.20	0.00
	Equipment Police	3,000.00	0.00	0.00	3,000.00	0.00	3,000.00	100.00
	Service & Repair - Equipment	500.00	0.00	0.00	500.00	0.00	500.00	100.00
	Misc/Equipment - Police	500.00	0.00	0.00	500.00	0.00	500.00	100.00
	Dues & Subscriptions	1,700.00	0.00	201.50	1,498.50	0.00	1,498.50	88.15
	Comm Crime Prevention Outreach	5,000.00	0.00	310.95	4,689.05	0.00	4,689.05	93.78
	Safety Program	2,200.00	189.40	189.40	2,010.60	0.00	2,010.60	91.39
	Radios - Police	15,000.00	0.00	0.00	15,000.00	0.00	15,000.00	100.00
	Computer Software	46,020.00	11,901.00	37,951.00	8,069.00	0.00	8,069.00	17.53
E40	E40 Sub Totals:	104,920.00	14,017.21	44,826.14	60,093.86	1,841.58	58,252.28	55.52
E55	Professional Services							
	Prof Services - Advertising	1,800.00	0.00	0.00	1,800.00	0.00	1,800.00	100.00
	Prof Services - Bldg & Grounds	5,000.00	989.68	1,292.02	3,707.98	1,550.39	2,157.59	43.15
	Prof Services - Other	14,700.00	998.37	1,611.85	13,088.15	708.54	12,379.61	84.22
	Prof Services - Printing	2,750.00	95.00	285.00	2,465.00	0.00	2,465.00	89.64
	Interpreter-Police	2,500.00	360.00	540.00	1,960.00	0.00	1,960.00	78.40
E55	E55 Sub Totals:	26,750.00	2,443.05	3,728.87	23,021.13	2,258.93	20,762.20	77.62
E60	Miscellaneous Expense							

Account Number	Description	Budget Amount	Period Amount	YTD Amount	YTD Var	Encumbered Amount	Available	% Available
001-0600-5606	Computer Maint & Support	17,660.00	2,478.00	4,818.00	12,842.00	10,530.00	2,312.00	13.09
001-0600-5617	Misc/Equipment Police	1,400.00	0.00	0.00	1,400.00	0.00	1,400.00	100.00
E60 Sub Totals:		19,060.00	2,478.00	4,818.00	14,242.00	10,530.00	3,712.00	19.48
E70	Grant Expense							
001-0600-5700	Grant Expense - Jag	6,700.00	0.00	0.00	6,700.00	0.00	6,700.00	100.00
E70 Sub Totals:		6,700.00	0.00	0.00	6,700.00	0.00	6,700.00	100.00
E80	Fixed Assets							
001-0600-5840	Principal Loan - Vehicles	322,215.00	0.00	0.00	322,215.00	0.00	322,215.00	100.00
E80 Sub Totals:		322,215.00	0.00	0.00	322,215.00	0.00	322,215.00	100.00
E85	Interest Expense							
001-0600-5850	Interest Expense	16,714.00	0.00	0.00	16,714.00	0.00	16,714.00	100.00
E85 Sub Totals:		16,714.00	0.00	0.00	16,714.00	0.00	16,714.00	100.00
Expense Sub Totals:		3,231,368.92	181,611.08	737,800.03	2,493,568.89	32,306.21	2,461,262.68	76.17
Dept 001-0610	Dept 0600 Sub Totals:	2,229,968.92	101,611.08	497,800.03	1,732,168.89	32,306.21		
R60	Miscellaneous Revenue							
001-0610-4650	Emerg Telephone Service Rev	70,000.00	21,598.42	21,598.42	48,401.58	0.00	48,401.58	69.15
R60 Sub Totals:		70,000.00	21,598.42	21,598.42	48,401.58	0.00	48,401.58	69.15
Revenue Sub Totals:		70,000.00	21,598.42	21,598.42	48,401.58	0.00	48,401.58	69.15
E01	Personnel Expense							
001-0610-5000	Salary Expense	245,025.19	16,645.37	61,049.39	183,975.80	0.00	183,975.80	75.08
001-0610-5010	Overtime Expense	35,000.00	2,611.54	7,816.58	27,183.42	0.00	27,183.42	77.67
001-0610-5020	FICA Expense	21,258.89	1,436.77	5,151.90	16,106.99	0.00	16,106.99	75.77
001-0610-5022	Unemployment Expense	3,888.57	0.00	0.00	3,888.57	0.00	3,888.57	100.00
001-0610-5025	Worker's Comp Expense	3,600.00	0.00	3,577.14	22.86	0.00	22.86	0.64
001-0610-5030	APERS Expense	36,665.22	2,764.39	10,028.22	26,637.00	0.00	26,637.00	72.65
001-0610-5040	Health Insurance Expense	49,715.52	4,646.99	13,421.52	36,294.00	0.00	36,294.00	73.00
E01 Sub Totals:		395,153.39	28,105.06	101,044.75	294,108.64	0.00	294,108.64	74.43
E55	Professional Services							
001-0610-5400	Comm Service Agreement	12,500.00	0.00	0.00	12,500.00	0.00	12,500.00	100.00
001-0610-5565	Prof Services - Dispatch	9,000.00	0.00	0.00	9,000.00	0.00	9,000.00	100.00
E55 Sub Totals:		21,500.00	0.00	0.00	21,500.00	0.00	21,500.00	100.00

Account Number	Description	Budget Amount	Period Amount	YTD Amount	YTD Var	Encumbered Amount	Available	% Available
	Expense Sub Totals:	416,653.39	28,105.06	101,044.75	315,608.64	0.00	315,608.64	75.75
Dept 001-0620	Dept 0610 Sub Totals:	346,653.39	6,506.64	79,446.33	267,207.06	0.00		
R64	Reimbursement							
001-0620-4640	Bryant School - SRO Reim	228,000.00	0.00	0.00	228,000.00	0.00	228,000.00	100.00
	R64 Sub Totals:	228,000.00	0.00	0.00	228,000.00	0.00	228,000.00	100.00
	Revenue Sub Totals:	228,000.00	0.00	0.00	228,000.00	0.00	228,000.00	100.00
E01	Personnel Expense							
001-0620-5000	Salary Expense	297,498.40	18,591.93	72,058.95	225,439.45	0.00	225,439.45	75.78
001-0620-5010	Overtime Expense	0.00	53.58	114.74	-114.74	0.00	-114.74	0.00
001-0620-5020	FICA Expense	22,913.63	1,407.56	5,459.54	17,454.09	0.00	17,454.09	76.17
001-0620-5022	Unemployment Expense	2,520.00	0.00	0.00	2,520.00	0.00	2,520.00	100.00
001-0620-5025	Worker's Comp Expense	4,600.00	0.00	4,552.73	47.27	0.00	47.27	1.03
001-0620-5035	LOPFI - SRO	65,449.65	4,148.23	16,016.82	49,432.83	0.00	49,432.83	75.53
001-0620-5036	LOPFE Prem Advance - SRO	-22,000.00	0.00	0.00	-22,000.00	0.00	-22,000.00	0.00
001-0620-5040	Health Insurance Expense	59,147.04	4,177.58	12,533.56	46,613.48	0.00	46,613.48	78.81
001-0620-5050	Phys/ Drug Test - SRO	500.00	0.00	0.00	500.00	0.00	500.00	100.00
001-0620-5055	Uniform Replacement	0.00	0.00	60.00	-60.00	0.00	-60.00	0.00
001-0620-5056	Uniform Allowance-SRO Cleaning	5,810.00	210.00	570.00	5,240.00	275.00	4,965.00	85.46
001-0620-5060	Travel & Training Expense	7,000.00	0.00	0.00	7,000.00	3,000.00	4,000.00	57.14
	E01 Sub Totals:	443,438.72	28,588.88	111,366.34	332,072.38	3,275.00	328,797.38	74.15
E10	Building & Grounds Exp							
001-0620-5116	Communication Exp - Cellular	5,700.00	451.72	1,398.60	4,301.40	0.00	4,301.40	75.46
	E10 Sub Totals:	5,700.00	451.72	1,398.60	4,301.40	0.00	4,301.40	75.46
E60	Miscellaneous Expense							
001-0620-5608	Computer Software	500.00	0.00	0.00	500.00	0.00	500.00	100.00
	E60 Sub Totals:	500.00	0.00	0.00	500.00	0.00	500.00	100.00
	Expense Sub Totals:	449,638.72	29,040.60	112,764.94	336,873.78	3,275.00	333,598.78	74.19
	Dept 0620 Sub Totals:	221,638.72	29,040.60	112,764.94	108,873.78	3,275.00		
Dept 001-0630	Supply Expense							
E30	Supplies - Food Allowance	1,000.00	118.78	342.19	657.81	0.00	657.81	65.78
001-0630-5306	E30 Sub Totals:	1,000.00	118.78	342.19	657.81	0.00	657.81	65.78

Account Number	Description	Budget Amount	Period Amount	YTD Amount	YTD Var	Encumbered Amount	Available	% Available
E40	Operations Expense							
001-0630-5500	K9 Training	3,500.00	18.53	18.53	3,481.47	0.00	3,481.47	99.47
E40 Sub Totals:		3,500.00	18.53	18.53	3,481.47	0.00	3,481.47	99.47
E55	Professional Services							
001-0630-5592	Prof Services - Veterinarian	2,800.00	989.90	989.90	1,810.10	200.00	1,610.10	57.50
E55 Sub Totals:		2,800.00	989.90	989.90	1,810.10	200.00	1,610.10	57.50
Expense Sub Totals:		7,300.00	1,127.21	1,350.62	5,949.38	200.00	5,749.38	78.76
Dept 0630 Sub Totals:		7,300.00	1,127.21	1,350.62	5,949.38	200.00		
Taxes - Sales								
001-0700-4656	Alcohol Sales Tax Collected	0.00	0.00	0.00	0.00	0.00	0.00	0.00
R10 Sub Totals:		0.00	0.00	0.00	0.00	0.00	0.00	0.00
R20	Licenses Permits & Fees							
001-0700-4200	Act 474 Commercial Surcharge	3,000.00	4.00	3,648.30	-648.30	0.00	-648.30	0.00
001-0700-4204	Amusement Game Fees	100.00	0.00	100.00	0.00	0.00	0.00	0.00
001-0700-4208	Business License	60,000.00	4,075.00	13,956.25	46,043.75	0.00	46,043.75	76.74
001-0700-4210	Commercial Remodel Permits	2,500.00	0.00	34.68	2,465.32	0.00	2,465.32	98.61
001-0700-4212	Drainage Fees	2,000.00	323.53	1,503.53	496.47	0.00	496.47	24.82
001-0700-4214	Electrical Permits	20,000.00	1,851.36	14,315.32	5,684.68	638.16	5,046.52	25.23
001-0700-4216	Electrical Reinspection	500.00	120.00	210.00	290.00	0.00	290.00	58.00
001-0700-4218	Fence Permits	700.00	50.00	25.00	675.00	0.00	675.00	96.43
001-0700-4220	HVACR Permits	10,000.00	1,076.16	5,932.98	4,067.02	0.00	4,067.02	40.67
001-0700-4226	Mobile Home Permits	500.00	0.00	150.00	350.00	0.00	350.00	70.00
001-0700-4228	New Commercial Permits	10,000.00	0.00	11,348.08	-1,348.08	0.00	-1,348.08	0.00
001-0700-4230	Permits - Other	4,000.00	100.00	1,302.24	2,697.76	50.00	2,647.76	66.19
001-0700-4232	Plumbing/Gas Inspections	10,000.00	550.30	5,844.98	4,155.02	0.00	4,155.02	41.55
001-0700-4234	Re-Inspection Fees	1,000.00	180.00	210.00	790.00	0.00	790.00	79.00
001-0700-4236	Residential Building Permits	10,000.00	794.55	2,231.20	7,768.80	0.00	7,768.80	77.69
001-0700-4238	Residential Remodel Permits	300.00	35.00	106.40	193.60	0.00	193.60	64.53
001-0700-4240	Sanitation License	300.00	25.00	125.00	175.00	0.00	175.00	58.33
001-0700-4242	Sign Permits	5,000.00	178.00	5,148.00	-148.00	0.00	-148.00	0.00
001-0700-4244	Solicitation Permits	700.00	60.00	75.00	625.00	0.00	625.00	89.29
001-0700-4248	Storage Building Permits	400.00	30.80	332.61	67.39	0.00	67.39	16.85
001-0700-4252	Swimming Pool Permits	300.00	0.00	120.00	180.00	0.00	180.00	60.00
001-0700-4258	Alcohol Permits - Revenue	15,610.00	2,610.00	2,985.00	12,625.00	0.00	12,625.00	80.88
R20 Sub Totals:		156,910.00	12,063.70	69,704.57	87,205.43	688.16	86,517.27	55.14
R64	Reimbursement							
001-0700-4560	Vacant Home Cleanup - Revenue	0.00	0.00	235.00	-235.00	0.00	-235.00	0.00

Account Number	Description	Budget Amount	Period Amount	YTD Amount	YTD Var	Encumbered Amount	Available	% Available
R64	Sub Totals:	0.00	0.00	235.00	-235.00	0.00	-235.00	0.00
Revenue Sub Totals:		156,910.00	12,063.70	69,939.57	86,970.43	688.16	86,282.27	54.99
E01	Personnel Expense							
001-0700-5000	Salary Expense	148,631.60	11,464.23	39,791.83	108,839.77	0.00	108,839.77	73.23
001-0700-5010	Overtime Expense	2,000.00	253.02	325.31	1,674.69	0.00	1,674.69	83.73
001-0700-5012	First Aid Code	100.00	0.00	0.00	100.00	0.00	100.00	100.00
001-0700-5020	FICA Expense	11,523.33	880.54	3,021.14	8,502.19	0.00	8,502.19	73.78
001-0700-5022	Unemployment Expense	1,440.00	0.00	0.00	1,440.00	0.00	1,440.00	100.00
001-0700-5025	Worker's Comp Expense	500.00	0.00	447.34	52.66	0.00	52.66	10.53
001-0700-5030	APERS Expense	22,361.27	1,729.46	5,921.28	16,439.99	0.00	16,439.99	73.52
001-0700-5040	Health Insurance Expense	31,811.52	2,650.96	8,032.88	23,778.64	0.00	23,778.64	74.75
001-0700-5050	Physical & Drug Screen Exp	325.00	0.00	0.00	325.00	0.00	325.00	100.00
001-0700-5055	Uniform Expense	1,500.00	0.00	150.93	1,349.07	0.00	1,349.07	89.94
001-0700-5060	Travel & Training Expense	1,125.00	500.00	500.00	625.00	0.00	625.00	55.56
E01 Sub Totals:		221,317.72	17,478.21	58,190.71	163,127.01	0.00	163,127.01	73.71
E10	Building & Grounds Exp							
001-0700-5100	Building & Grounds Reim	1,500.00	105.42	237.43	1,262.57	15.80	1,246.77	83.12
001-0700-5110	Utilities - Electric Expense	1,000.00	0.00	12.38	987.62	0.00	987.62	98.76
001-0700-5111	Utilities - Gas Expense	1,000.00	0.00	0.00	1,000.00	0.00	1,000.00	100.00
001-0700-5115	Communication Exp - Telephone	1,500.00	268.98	403.86	1,096.14	0.00	1,096.14	73.08
001-0700-5120	Insurance - Property	300.00	0.00	0.00	300.00	0.00	300.00	100.00
E10 Sub Totals:		5,300.00	374.40	653.67	4,646.33	15.80	4,630.53	87.37
E20	Vehicle Expense							
001-0700-5200	Fuel Expense	8,000.00	394.05	1,265.71	6,734.29	0.00	6,734.29	84.18
001-0700-5210	Service & Repair - Vehicle	0.00	0.00	9.57	-9.57	0.00	-9.57	0.00
001-0700-5225	Insurance Expense - Vehicle	325.00	0.00	325.00	0.00	0.00	0.00	0.00
E20 Sub Totals:		8,325.00	394.05	1,600.28	6,724.72	0.00	6,724.72	80.78
E40	Operations Expense							
001-0700-5116	Communication Exp - Cellular	1,800.00	197.88	593.40	1,206.60	0.00	1,206.60	67.03
001-0700-5405	Act 474 Surcharge	8,000.00	5,385.37	7,746.40	253.60	0.00	253.60	3.17
001-0700-5475	Credit Card Fees	1,200.00	127.98	631.84	568.16	0.00	568.16	47.35
001-0700-5480	Dues & Subscriptions	500.00	7.49	215.22	284.78	0.00	284.78	56.96
001-0700-5560	Vacant Home Cleanup	4,000.00	0.00	0.00	4,000.00	0.00	4,000.00	100.00
E40 Sub Totals:		15,500.00	5,718.72	9,186.86	6,313.14	0.00	6,313.14	40.73
E55	Professional Services							
001-0700-5568	Prof Services - Elec Insp	10,000.00	552.50	1,920.00	8,080.00	0.00	8,080.00	80.80
001-0700-5589	Prof Services - Printing	500.00	20.00	60.00	440.00	0.00	440.00	88.00

Account Number	Description	Budget Amount	Period Amount	YTD Amount	YTD Var	Encumbered Amount	Available	% Available
	E55 Sub Totals:	10,500.00	572.50	1,980.00	8,520.00	0.00	8,520.00	81.14
	Expense Sub Totals:	260,942.72	24,537.88	71,611.52	189,331.20	15.80	189,315.40	72.55
	Dept 0700 Sub Totals:	104,032.72	12,474.18	1,671.95	102,360.77	703.96		
	Fund Revenue Sub Totals:	12,059,930.00	1,005,779.30	2,840,655.22	9,219,274.78	688.16	9,218,586.62	76.44
	Fund Expense Sub Totals:	12,077,162.31	731,750.15	2,836,738.36	9,240,423.95	191,646.92	9,048,777.03	74.92
	Fund 001 Sub Totals:	17,232.31	-274,029.15	-3,916.86	21,149.17	192,335.08		

Account Number	Description	Budget Amount	Period Amount	YTD Amount	YTD Var	Encumbered Amount	Available	% Available
Fund 002	Sales Tax Fund							
Dept 002-0100	Administration							
R10	Taxes - Sales							
002-0100-4105	One Cent Sales Tax	3,835,000.00	272,456.24	960,460.76	2,874,539.24	0.00	2,874,539.24	74.96
	R10 Sub Totals:	3,835,000.00	272,456.24	960,460.76	2,874,539.24	0.00	2,874,539.24	74.96
R85	Interest Revenue							
002-0100-4850	Interest Revenue	0.00	20.69	52.25	-52.25	0.00	-52.25	0.00
	R85 Sub Totals:	0.00	20.69	52.25	-52.25	0.00	-52.25	0.00
	Revenue Sub Totals:	3,835,000.00	272,476.93	960,513.01	2,874,486.99	0.00	2,874,486.99	74.95
E62	Intergovernmental Tsfr							
002-0100-5620	Xfer to General	3,835,000.00	319,583.33	958,749.99	2,876,250.01	0.00	2,876,250.01	75.00
	E62 Sub Totals:	3,835,000.00	319,583.33	958,749.99	2,876,250.01	0.00	2,876,250.01	75.00
	Expense Sub Totals:	3,835,000.00	319,583.33	958,749.99	2,876,250.01	0.00	2,876,250.01	75.00
	Dept 0100 Sub Totals:	0.00	47,106.40	-1,763.02	1,763.02	0.00		
	Fund Revenue Sub Totals:	3,835,000.00	272,476.93	960,513.01	2,874,486.99	0.00	2,874,486.99	74.95
	Fund Expense Sub Totals:	3,835,000.00	319,583.33	958,749.99	2,876,250.01	0.00	2,876,250.01	75.00
	Fund 002 Sub Totals:	0.00	47,106.40	-1,763.02	1,763.02	0.00		

Account Number	Description	Budget Amount	Period Amount	YTD Amount	YTD Var	Encumbered Amount	Available	% Available
Fund 003	Franchise Fees							
Dept 003-0100	Administration							
R50	Sale of Services							
003-0100-4502	AT&T / SW Bell Franchise Fee	125,000.00	0.00	29,612.46	95,387.54	0.00	95,387.54	76.31
003-0100-4506	Centerpoint Energy Franchise Fee	200,000.00	37,680.51	111,683.96	88,316.04	0.00	88,316.04	44.16
003-0100-4508	Fidelity Franchise Fee	15,000.00	0.00	11,918.51	3,081.49	0.00	3,081.49	20.54
003-0100-4510	Comcast Cable Franchise Fee	75,000.00	0.00	19,672.80	55,327.20	0.00	55,327.20	73.77
003-0100-4526	Energy Franchise Fee	500,000.00	46,299.71	132,354.95	367,645.05	0.00	367,645.05	73.53
003-0100-4528	First Electric Franchise Fee	250,000.00	21,463.81	69,125.66	180,874.34	0.00	180,874.34	72.35
003-0100-4564	Windstream Franchise Fee	0.00	0.00	0.00	0.00	0.00	0.00	0.00
R50 Sub Totals:		1,165,000.00	105,444.03	374,368.34	790,631.66	0.00	790,631.66	67.87
R85	Interest Revenue							
003-0100-4850	Interest Revenue	120.00	29.34	74.04	45.96	0.00	45.96	38.30
R85 Sub Totals:		120.00	29.34	74.04	45.96	0.00	45.96	38.30
E62	Revenue Sub Totals:	1,165,120.00	105,473.37	374,442.38	790,677.62	0.00	790,677.62	67.86
E62	Intergovernmental Tsfr							
003-0100-5620	Xfer to General	420,120.00	105,030.00	105,030.00	315,090.00	0.00	315,090.00	75.00
003-0100-5622	Xfer to Street	360,000.00	29,298.75	87,896.25	272,103.75	0.00	272,103.75	75.58
E62 Sub Totals:		780,120.00	134,328.75	192,926.25	587,193.75	0.00	587,193.75	75.27
E62	Expense Sub Totals:	780,120.00	134,328.75	192,926.25	587,193.75	0.00	587,193.75	75.27
Dept 0100 Sub Totals:		-385,000.00	28,855.38	-181,516.13	-203,483.87	0.00		
Dept 003-0400	Intergovernmental Tsfr							
E62	Xfer to Other	385,000.00	29,747.30	89,069.60	295,930.40	267,725.70	28,204.70	7.33
003-0400-5626	E62 Sub Totals:	385,000.00	29,747.30	89,069.60	295,930.40	267,725.70	28,204.70	7.33
E62	Expense Sub Totals:	385,000.00	29,747.30	89,069.60	295,930.40	267,725.70	28,204.70	7.33
Dept 0400 Sub Totals:		385,000.00	29,747.30	89,069.60	295,930.40	267,725.70		
Fund Revenue Sub Totals:		1,165,120.00	105,473.37	374,442.38	790,677.62	0.00	790,677.62	67.86
Fund Expense Sub Totals:		1,165,120.00	164,076.05	281,995.85	883,124.15	267,725.70	615,398.45	52.82
Fund 003 Sub Totals:		0.00	58,602.68	-92,446.53	92,446.53	267,725.70		

Account Number	Description	Budget Amount	Period Amount	YTD Amount	YTD Var	Encumbered Amount	Available	% Available
Fund 005	Designated Tax Fund - Gen'l							
Dept 005-0100	Administration							
R85	Interest Revenue	250.00	62.76	169.78	80.22	0.00	80.22	32.09
005-0100-4850	Interest Revenue							
	R85 Sub Totals:	250.00	62.76	169.78	80.22	0.00	80.22	32.09
	Revenue Sub Totals:	250.00	62.76	169.78	80.22	0.00	80.22	32.09
Dept 005-0200	Dept 0100 Sub Totals:	-250.00	-62.76	-169.78	-80.22	0.00		
R10	Animal Control							
005-0200-4100	Taxes - Sales							
	Designated Tax - AC	383,000.00	27,255.09	96,080.05	286,919.95	0.00	286,919.95	74.91
	R10 Sub Totals:	383,000.00	27,255.09	96,080.05	286,919.95	0.00	286,919.95	74.91
	Revenue Sub Totals:	383,000.00	27,255.09	96,080.05	286,919.95	0.00	286,919.95	74.91
E62	Intergovernmental Tsfr							
005-0200-5620	Xfer to General - AC	383,000.00	31,916.66	95,749.98	287,250.02	0.00	287,250.02	75.00
	E62 Sub Totals:	383,000.00	31,916.66	95,749.98	287,250.02	0.00	287,250.02	75.00
	Expense Sub Totals:	383,000.00	31,916.66	95,749.98	287,250.02	0.00	287,250.02	75.00
Dept 005-0400	Dept 0200 Sub Totals:	0.00	4,661.57	-330.07	330.07	0.00		
R10	Parks General							
005-0400-4100	Taxes - Sales							
	Designated Tax - Park	383,000.00	27,255.09	96,080.05	286,919.95	0.00	286,919.95	74.91
	R10 Sub Totals:	383,000.00	27,255.09	96,080.05	286,919.95	0.00	286,919.95	74.91
	Revenue Sub Totals:	383,000.00	27,255.09	96,080.05	286,919.95	0.00	286,919.95	74.91
E62	Intergovernmental Tsfr							
005-0400-5620	Xfer to General - Park	383,000.00	31,916.66	95,749.98	287,250.02	0.00	287,250.02	75.00
	E62 Sub Totals:	383,000.00	31,916.66	95,749.98	287,250.02	0.00	287,250.02	75.00
	Expense Sub Totals:	383,000.00	31,916.66	95,749.98	287,250.02	0.00	287,250.02	75.00
Dept 005-0500	Dept 0400 Sub Totals:	0.00	4,661.57	-330.07	330.07	0.00		
R10	Fire Department							
	Taxes - Sales							

Account Number	Description	Budget Amount	Period Amount	YTD Amount	YTD Var	Encumbered Amount	Available	% Available
005-0500-4100	Designated Tax - Fire	960,000.00	68,137.76	240,200.16	719,799.84	0.00	719,799.84	74.98
	R10 Sub Totals:	960,000.00	68,137.76	240,200.16	719,799.84	0.00	719,799.84	74.98
E62	Revenue Sub Totals:	960,000.00	68,137.76	240,200.16	719,799.84	0.00	719,799.84	74.98
005-0500-5620	Intergovernmental Tsfr							
	Xfer to General - Fire	960,000.00	80,000.00	240,000.00	720,000.00	0.00	720,000.00	75.00
	E62 Sub Totals:	960,000.00	80,000.00	240,000.00	720,000.00	0.00	720,000.00	75.00
	Expense Sub Totals:	960,000.00	80,000.00	240,000.00	720,000.00	0.00	720,000.00	75.00
Dept 005-0600	Dept 0500 Sub Totals:	0.00	11,862.24	-200.16	200.16	0.00		
R10	Police							
	Taxes - Sales							
005-0600-4100	Designated Tax - Police	960,000.00	68,137.76	240,200.16	719,799.84	0.00	719,799.84	74.98
	R10 Sub Totals:	960,000.00	68,137.76	240,200.16	719,799.84	0.00	719,799.84	74.98
E62	Revenue Sub Totals:	960,000.00	68,137.76	240,200.16	719,799.84	0.00	719,799.84	74.98
005-0600-5620	Intergovernmental Tsfr							
	Xfer to General - Police	960,000.00	80,000.00	240,000.00	720,000.00	0.00	720,000.00	75.00
	E62 Sub Totals:	960,000.00	80,000.00	240,000.00	720,000.00	0.00	720,000.00	75.00
	Expense Sub Totals:	960,000.00	80,000.00	240,000.00	720,000.00	0.00	720,000.00	75.00
Dept 005-0800	Dept 0600 Sub Totals:	0.00	11,862.24	-200.16	200.16	0.00		
R10	Street							
	Taxes - Sales							
005-0800-4100	Designated Tax - Street	1,440,000.00	81,765.29	288,240.21	1,151,759.79	0.00	1,151,759.79	79.98
	R10 Sub Totals:	1,440,000.00	81,765.29	288,240.21	1,151,759.79	0.00	1,151,759.79	79.98
E62	Revenue Sub Totals:	1,440,000.00	81,765.29	288,240.21	1,151,759.79	0.00	1,151,759.79	79.98
005-0800-5622	Intergovernmental Tsfr							
	Xfer to Street	1,073,000.00	89,416.66	268,249.98	804,750.02	0.00	804,750.02	75.00
	E62 Sub Totals:	1,073,000.00	89,416.66	268,249.98	804,750.02	0.00	804,750.02	75.00
	Expense Sub Totals:	1,073,000.00	89,416.66	268,249.98	804,750.02	0.00	804,750.02	75.00

Account Number	Description	Budget Amount	Period Amount	YTD Amount	YTD Var	Encumbered Amount	Available	% Available
	Dept 0800 Sub Totals:	-367,000.00	7,651.37	-19,990.23	-347,009.77	0.00		
	Fund Revenue Sub Totals:	4,126,250.00	272,613.75	960,970.41	3,165,279.59	0.00	3,165,279.59	76.71
	Fund Expense Sub Totals:	3,759,000.00	313,249.98	939,749.94	2,819,250.06	0.00	2,819,250.06	75.00
	Fund 005 Sub Totals:	-367,250.00	40,636.23	-21,220.47	-346,029.53	0.00		

Account Number	Description	Budget Amount	Period Amount	YTD Amount	YTD Var	Encumbered Amount	Available	% Available
Fund 020	Animal Control Donation							
Dept 020-0200								
R68								
020-0200-4680	Donation Revenue	4,500.00	0.00	817.01	3,682.99	0.00	3,682.99	81.84
020-0200-4682	Donations Dog Park	5,000.00	0.00	20.00	4,980.00	0.00	4,980.00	99.60
	R68 Sub Totals:	9,500.00	0.00	837.01	8,662.99	0.00	8,662.99	91.19
R85	Interest Revenue							
020-0200-4850	Interest Revenue	0.00	0.50	1.27	-1.27	0.00	-1.27	0.00
	R85 Sub Totals:	0.00	0.50	1.27	-1.27	0.00	-1.27	0.00
	Revenue Sub Totals:	9,500.00	0.50	838.28	8,661.72	0.00	8,661.72	91.18
E68	Donation Expense							
020-0200-5580	AC Donation Expense	9,500.00	0.00	0.00	9,500.00	0.00	9,500.00	100.00
	E68 Sub Totals:	9,500.00	0.00	0.00	9,500.00	0.00	9,500.00	100.00
	Expense Sub Totals:	9,500.00	0.00	0.00	9,500.00	0.00	9,500.00	100.00
	Dept 0200 Sub Totals:	0.00	-0.50	-838.28	838.28	0.00		
	Fund Revenue Sub Totals:	9,500.00	0.50	838.28	8,661.72	0.00	8,661.72	91.18
	Fund Expense Sub Totals:	9,500.00	0.00	0.00	9,500.00	0.00	9,500.00	100.00
	Fund 020 Sub Totals:	0.00	-0.50	-838.28	838.28	0.00		

Account Number	Description	Budget Amount	Period Amount	YTD Amount	YTD Var	Encumbered Amount	Available	% Available
Fund 030	Act 1256 of 1995 Court							
Dept 030-0300								
R40	Fines & Forfeitures							
030-0300-4404	Act 1256 Civil Division	71,250.00	4,355.00	11,570.00	59,680.00	0.00	59,680.00	83.76
030-0300-4406	Act 1256 District Court Rev	360,000.00	25,422.08	75,934.68	284,065.32	0.00	284,065.32	78.91
	R40 Sub Totals:	431,250.00	29,777.08	87,504.68	343,745.32	0.00	343,745.32	79.71
	Revenue Sub Totals:	431,250.00	29,777.08	87,504.68	343,745.32	0.00	343,745.32	79.71
E01	Personnel Expense							
030-0300-5072	Act 1256 Judge Retirement	5,200.00	394.84	1,177.54	4,022.46	0.00	4,022.46	77.36
	E01 Sub Totals:	5,200.00	394.84	1,177.54	4,022.46	0.00	4,022.46	77.36
E40	Operations Expense							
030-0300-5400	Act 316 of 1991 Expense	250.00	18.12	54.44	195.56	0.00	195.56	78.22
030-0300-5415	Act 918 of 1983 Expense	17,500.00	1,342.64	4,004.18	13,495.82	0.00	13,495.82	77.12
030-0300-5425	Act 1256 Co Admin of Justice	140,500.00	10,741.60	32,034.87	108,465.13	0.00	108,465.13	77.20
030-0300-5430	Act 1256 Court Costs	15,250.00	1,181.04	3,522.24	11,727.76	0.00	11,727.76	76.90
030-0300-5435	Act 1256 City Attorney	28,500.00	2,190.68	6,533.30	21,966.70	0.00	21,966.70	77.08
030-0300-5440	Act 1256 DFA (State)	197,250.00	11,874.42	34,113.25	163,136.75	0.00	163,136.75	82.71
030-0300-5445	Act 1256 Ordinance 89-15	26,000.00	1,966.60	5,865.03	20,134.97	0.00	20,134.97	77.44
030-0300-5495	Act 1256 Intoximeter Expense	900.00	67.14	200.23	699.77	0.00	699.77	77.75
	E40 Sub Totals:	426,150.00	29,382.24	86,327.54	339,822.46	0.00	339,822.46	79.74
	Expense Sub Totals:	431,350.00	29,777.08	87,505.08	343,844.92	0.00	343,844.92	79.71
	Dept 0300 Sub Totals:	100.00	0.00	0.40	99.60	0.00		
	Fund Revenue Sub Totals:	431,250.00	29,777.08	87,504.68	343,745.32	0.00	343,745.32	79.71
	Fund Expense Sub Totals:	431,350.00	29,777.08	87,505.08	343,844.92	0.00	343,844.92	79.71
	Fund 030 Sub Totals:	100.00	0.00	0.40	99.60	0.00		

Account Number	Description	Budget Amount	Period Amount	YTD Amount	YTD Var	Encumbered Amount	Available	% Available
Fund 031	Act 1809 of 2001 Court Auto							
Dept 031-0300	Fines & Forfeitures							
R40	Act 1809 of 2001 Revenue	26,000.00	4,220.50	10,356.90	15,643.10	0.00	15,643.10	60.17
031-0300-4408	R40 Sub Totals:	26,000.00	4,220.50	10,356.90	15,643.10	0.00	15,643.10	60.17
R85	Interest Revenue	0.00	2.67	7.39	-7.39	0.00	-7.39	0.00
031-0300-4850	Interest Revenue	0.00	2.67	7.39	-7.39	0.00	-7.39	0.00
	R85 Sub Totals:							
	Revenue Sub Totals:	26,000.00	4,223.17	10,364.29	15,635.71	0.00	15,635.71	60.14
E60	Miscellaneous Expense							
031-0300-5608	Computer Software	32,250.00	1,860.50	5,581.50	26,668.50	16,744.50	9,924.00	30.77
	E60 Sub Totals:	32,250.00	1,860.50	5,581.50	26,668.50	16,744.50	9,924.00	30.77
	Expense Sub Totals:	32,250.00	1,860.50	5,581.50	26,668.50	16,744.50	9,924.00	30.77
	Dept 0300 Sub Totals:	6,250.00	-2,362.67	-4,782.79	11,032.79	16,744.50		
	Fund Revenue Sub Totals:	26,000.00	4,223.17	10,364.29	15,635.71	0.00	15,635.71	60.14
	Fund Expense Sub Totals:	32,250.00	1,860.50	5,581.50	26,668.50	16,744.50	9,924.00	30.77
	Fund 031 Sub Totals:	6,250.00	-2,362.67	-4,782.79	11,032.79	16,744.50		

Account Number	Description	Budget Amount	Period Amount	YTD Amount	YTD Var	Encumbered Amount	Available	% Available
Fund 045	Park 1/8 SalesTax O & M							
Dept 045-0400	Parks General							
R10	Taxes - Sales							
045-0400-4110	Park 1/8 Sales Tax	480,000.00	34,068.87	120,100.08	359,899.92	0.00	359,899.92	74.98
	R10 Sub Totals:	480,000.00	34,068.87	120,100.08	359,899.92	0.00	359,899.92	74.98
R85	Interest Revenue							
045-0400-4850	Interest Revenue	0.00	2.54	6.51	-6.51	0.00	-6.51	0.00
	R85 Sub Totals:	0.00	2.54	6.51	-6.51	0.00	-6.51	0.00
	Revenue Sub Totals:	480,000.00	34,071.41	120,106.59	359,893.41	0.00	359,893.41	74.98
E62	Intergovernmental Tsfr							
045-0400-5620	Xfer to General	480,000.00	40,000.00	120,000.00	360,000.00	0.00	360,000.00	75.00
	E62 Sub Totals:	480,000.00	40,000.00	120,000.00	360,000.00	0.00	360,000.00	75.00
	Expense Sub Totals:	480,000.00	40,000.00	120,000.00	360,000.00	0.00	360,000.00	75.00
	Dept 0400 Sub Totals:	0.00	5,928.59	-106.59	106.59	0.00		
	Fund Revenue Sub Totals:	480,000.00	34,071.41	120,106.59	359,893.41	0.00	359,893.41	74.98
	Fund Expense Sub Totals:	480,000.00	40,000.00	120,000.00	360,000.00	0.00	360,000.00	75.00
	Fund 045 Sub Totals:	0.00	5,928.59	-106.59	106.59	0.00		

Account Number	Description	Budget Amount	Period Amount	YTD Amount	YTD Var	Encumbered Amount	Available	% Available
Fund 050	Fire Donation							
Dept 050-0500	Fire Department							
R68	Donation Revenue							
050-0500-4680	Donation Revenue	1,000.00	0.00	286.59	713.41	0.00	713.41	71.34
	R68 Sub Totals:	1,000.00	0.00	286.59	713.41	0.00	713.41	71.34
R85	Interest Revenue							
050-0500-4850	Interest Revenue	0.00	0.12	0.32	-0.32	0.00	-0.32	0.00
	R85 Sub Totals:	0.00	0.12	0.32	-0.32	0.00	-0.32	0.00
	Revenue Sub Totals:	1,000.00	0.12	286.91	713.09	0.00	713.09	71.31
E68	Donation Expense							
050-0500-5580	Donations Expense Fire	1,000.00	0.00	0.00	1,000.00	0.00	1,000.00	100.00
	E68 Sub Totals:	1,000.00	0.00	0.00	1,000.00	0.00	1,000.00	100.00
	Expense Sub Totals:	1,000.00	0.00	0.00	1,000.00	0.00	1,000.00	100.00
	Dept 0500 Sub Totals:	0.00	-0.12	-286.91	286.91	0.00		
	Fund Revenue Sub Totals:	1,000.00	0.12	286.91	713.09	0.00	713.09	71.31
	Fund Expense Sub Totals:	1,000.00	0.00	0.00	1,000.00	0.00	1,000.00	100.00
	Fund 050 Sub Totals:	0.00	-0.12	-286.91	286.91	0.00		

Account Number	Description	Budget Amount	Period Amount	YTD Amount	YTD Var	Encumbered Amount	Available	% Available
Fund 051	Act 833 of 1991 Fire							
Dept 051-0500	Fire Department							
R15	Taxes - Property							
051-0500-4150	State Turnback	15,000.00	0.00	870.23	14,129.77	0.00	14,129.77	94.20
	R15 Sub Totals:	15,000.00	0.00	870.23	14,129.77	0.00	14,129.77	94.20
R85	Interest Revenue							
051-0500-4850	Interest Revenue	0.00	1.32	3.73	-3.73	0.00	-3.73	0.00
	R85 Sub Totals:	0.00	1.32	3.73	-3.73	0.00	-3.73	0.00
	Revenue Sub Totals:	15,000.00	1.32	873.96	14,126.04	0.00	14,126.04	94.17
E40	Operations Expense							
051-0500-5410	Act 833 Expense	15,000.00	0.00	624.15	14,375.85	0.00	14,375.85	95.84
	E40 Sub Totals:	15,000.00	0.00	624.15	14,375.85	0.00	14,375.85	95.84
	Expense Sub Totals:	15,000.00	0.00	624.15	14,375.85	0.00	14,375.85	95.84
	Dept 0500 Sub Totals:	0.00	-1.32	-249.81	249.81	0.00		
	Fund Revenue Sub Totals:	15,000.00	1.32	873.96	14,126.04	0.00	14,126.04	94.17
	Fund Expense Sub Totals:	15,000.00	0.00	624.15	14,375.85	0.00	14,375.85	95.84
	Fund 051 Sub Totals:	0.00	-1.32	-249.81	249.81	0.00		

Account Number	Description	Budget Amount	Period Amount	YTD Amount	YTD Var	Encumbered Amount	Available	% Available
Fund 055	Fire 3/8 SalesTax							
Dept 055-0500	Fire Department							
R10	Taxes - Sales							
055-0500-4120	Fire 3/8 Sales Tax	1,440,000.00	102,206.62	360,300.22	1,079,699.78	0.00	1,079,699.78	74.98
	R10 Sub Totals:	1,440,000.00	102,206.62	360,300.22	1,079,699.78	0.00	1,079,699.78	74.98
R85	Interest Revenue							
055-0500-4850	Interest Revenue	0.00	14.29	36.91	-36.91	0.00	-36.91	0.00
055-0500-4855	Gain on Investment	0.00	0.00	0.00	0.00	0.00	0.00	0.00
	R85 Sub Totals:	0.00	14.29	36.91	-36.91	0.00	-36.91	0.00
	Revenue Sub Totals:	1,440,000.00	102,220.91	360,337.13	1,079,662.87	0.00	1,079,662.87	74.98
E62	Intergovernmental Tsfr							
055-0500-5620	Xfer to General	1,265,000.00	105,416.66	316,249.98	948,750.02	0.00	948,750.02	75.00
	E62 Sub Totals:	1,265,000.00	105,416.66	316,249.98	948,750.02	0.00	948,750.02	75.00
E80	Fixed Assets							
055-0500-5814	Fixed Assets - Fire Trucks	165,000.00	27,262.16	27,262.16	137,737.84	68,850.96	68,886.88	41.75
	E80 Sub Totals:	165,000.00	27,262.16	27,262.16	137,737.84	68,850.96	68,886.88	41.75
E85	Interest Expense							
055-0500-5850	Interest Expense	11,010.27	2,053.52	2,053.52	8,956.75	3,643.80	5,312.95	48.25
	E85 Sub Totals:	11,010.27	2,053.52	2,053.52	8,956.75	3,643.80	5,312.95	48.25
	Expense Sub Totals:	1,441,010.27	134,732.34	345,565.66	1,095,444.61	72,494.76	1,022,949.85	70.99
	Dept 0500 Sub Totals:	1,010.27	32,511.43	-14,771.47	15,781.74	72,494.76		
	Fund Revenue Sub Totals:	1,440,000.00	102,220.91	360,337.13	1,079,662.87	0.00	1,079,662.87	74.98
	Fund Expense Sub Totals:	1,441,010.27	134,732.34	345,565.66	1,095,444.61	72,494.76	1,022,949.85	70.99
	Fund 055 Sub Totals:	1,010.27	32,511.43	-14,771.47	15,781.74	72,494.76		

Account Number	Description	Budget Amount	Period Amount	YTD Amount	YTD Var	Encumbered Amount	Available	% Available
Fund 059	Firemen's Pension							
Dept 059-0500	Fire Department							
R64	Reimbursement							
059-0500-4645	LOPFI Subsidy	7,500.00	0.00	0.00	7,500.00	0.00	7,500.00	100.00
	R64 Sub Totals:	7,500.00	0.00	0.00	7,500.00	0.00	7,500.00	100.00
R85	Interest Revenue							
059-0500-4850	Interest Revenue	0.00	170.23	704.53	-704.53	0.00	-704.53	0.00
059-0500-4855	Gain on Investment	0.00	0.00	42.21	-42.21	0.00	-42.21	0.00
	R85 Sub Totals:	0.00	170.23	746.74	-746.74	0.00	-746.74	0.00
	Revenue Sub Totals:	7,500.00	170.23	746.74	6,753.26	0.00	6,753.26	90.04
E01	Personnel Expense							
059-0500-5038	Pension Expense	2,000.00	1,210.00	3,630.00	-1,630.00	0.00	-1,630.00	0.00
059-0500-5039	Pension Expense - Misc Exp	14,500.00	0.00	358.80	14,141.20	0.00	14,141.20	97.53
	E01 Sub Totals:	16,500.00	1,210.00	3,988.80	12,511.20	0.00	12,511.20	75.83
E85	Interest Expense							
059-0500-5855	Loss on Investment	0.00	572.58	589.33	-589.33	0.00	-589.33	0.00
	E85 Sub Totals:	0.00	572.58	589.33	-589.33	0.00	-589.33	0.00
	Expense Sub Totals:	16,500.00	1,782.58	4,578.13	11,921.87	0.00	11,921.87	72.25
	Dept 0500 Sub Totals:	9,000.00	1,612.35	3,831.39	5,168.61	0.00		
	Fund Revenue Sub Totals:	7,500.00	170.23	746.74	6,753.26	0.00	6,753.26	90.04
	Fund Expense Sub Totals:	16,500.00	1,782.58	4,578.13	11,921.87	0.00	11,921.87	72.25
	Fund 059 Sub Totals:	9,000.00	1,612.35	3,831.39	5,168.61	0.00		

Account Number	Description	Budget Amount	Period Amount	YTD Amount	YTD Var	Encumbered Amount	Available	% Available
Fund 060	Police Donation							
Dept 060-0600	Police							
R68	Donation Revenue							
060-0600-4680	Donation Revenue	1,000.00	0.00	0.00	1,000.00	0.00	1,000.00	100.00
	R68 Sub Totals:	1,000.00	0.00	0.00	1,000.00	0.00	1,000.00	100.00
R85	Interest Revenue							
060-0600-4850	Interest Revenue	0.00	0.08	0.22	-0.22	0.00	-0.22	0.00
	R85 Sub Totals:	0.00	0.08	0.22	-0.22	0.00	-0.22	0.00
	Revenue Sub Totals:	1,000.00	0.08	0.22	999.78	0.00	999.78	99.98
E60	Miscellaneous Expense							
060-0600-5600	Miscellaneous Expense	1,000.00	0.00	0.00	1,000.00	0.00	1,000.00	100.00
	E60 Sub Totals:	1,000.00	0.00	0.00	1,000.00	0.00	1,000.00	100.00
	Expense Sub Totals:	1,000.00	0.00	0.00	1,000.00	0.00	1,000.00	100.00
	Dept 0600 Sub Totals:	0.00	-0.08	-0.22	0.22	0.00		
	Fund Revenue Sub Totals:	1,000.00	0.08	0.22	999.78	0.00	999.78	99.98
	Fund Expense Sub Totals:	1,000.00	0.00	0.00	1,000.00	0.00	1,000.00	100.00
	Fund 060 Sub Totals:	0.00	-0.08	-0.22	0.22	0.00		

Account Number	Description	Budget Amount	Period Amount	YTD Amount	YTD Var	Encumbered Amount	Available	% Available
Fund 061	Act 918 of 1983 Police							
Dept 061-0600	Police							
R40	Fincs & Forfeitures							
061-0600-4410	Admin of Justice Revenue	20,000.00	1,342.64	4,004.18	15,995.82	0.00	15,995.82	79.98
	R40 Sub Totals:	20,000.00	1,342.64	4,004.18	15,995.82	0.00	15,995.82	79.98
R85	Interest Revenue	0.00	1.21	3.23	-3.23	0.00	-3.23	0.00
061-0600-4850	Interest Revenue	0.00	1.21	3.23	-3.23	0.00	-3.23	0.00
	R85 Sub Totals:	0.00	1.21	3.23	-3.23	0.00	-3.23	0.00
	Revenue Sub Totals:	20,000.00	1,343.85	4,007.41	15,992.59	0.00	15,992.59	79.96
E40	Operations Expense							
061-0600-5415	Act 918 of 1983 Expense	20,000.00	0.00	0.00	20,000.00	0.00	20,000.00	100.00
	E40 Sub Totals:	20,000.00	0.00	0.00	20,000.00	0.00	20,000.00	100.00
	Expense Sub Totals:	20,000.00	0.00	0.00	20,000.00	0.00	20,000.00	100.00
	Dept 0600 Sub Totals:	0.00	-1,343.85	-4,007.41	4,007.41	0.00		
	Fund Revenue Sub Totals:	20,000.00	1,343.85	4,007.41	15,992.59	0.00	15,992.59	79.96
	Fund Expense Sub Totals:	20,000.00	0.00	0.00	20,000.00	0.00	20,000.00	100.00
	Fund 061 Sub Totals:	0.00	-1,343.85	-4,007.41	4,007.41	0.00		

Account Number	Description	Budget Amount	Period Amount	YTD Amount	YTD Var	Encumbered Amount	Available	% Available
Fund 062	Act 988 of 1991 Emerg Veh							
Dept 062-0600	Police							
R40	Fines & Forfeitures							
062-0600-4402	Act 988 of 1991 Revenue	20,000.00	1,065.00	3,349.00	16,651.00	0.00	16,651.00	83.26
	R40 Sub Totals:	20,000.00	1,065.00	3,349.00	16,651.00	0.00	16,651.00	83.26
R85	Interest Revenue							
062-0600-4850	Interest Revenue	0.00	1.10	2.98	-2.98	0.00	-2.98	0.00
	R85 Sub Totals:	0.00	1.10	2.98	-2.98	0.00	-2.98	0.00
	Revenue Sub Totals:	20,000.00	1,066.10	3,351.98	16,648.02	0.00	16,648.02	83.24
E40	Operations Expense							
062-0600-5420	Act 988 Expense	20,000.00	0.00	0.00	20,000.00	0.00	20,000.00	100.00
	E40 Sub Totals:	20,000.00	0.00	0.00	20,000.00	0.00	20,000.00	100.00
	Expense Sub Totals:	20,000.00	0.00	0.00	20,000.00	0.00	20,000.00	100.00
	Dept 0600 Sub Totals:	0.00	-1,066.10	-3,351.98	3,351.98	0.00		
	Fund Revenue Sub Totals:	20,000.00	1,066.10	3,351.98	16,648.02	0.00	16,648.02	83.24
	Fund Expense Sub Totals:	20,000.00	0.00	0.00	20,000.00	0.00	20,000.00	100.00
	Fund 062 Sub Totals:	0.00	-1,066.10	-3,351.98	3,351.98	0.00		

Account Number	Description	Budget Amount	Period Amount	YTD Amount	YTD Var	Encumbered Amount	Available	% Available
Fund 068	State Drug Control							
Dept 068-0600	Police							
R40	Fines & Forfeitures							
068-0600-4418	Drug Seizure Revenue	5,000.00	0.00	0.00	5,000.00	0.00	5,000.00	100.00
	R40 Sub Totals:	5,000.00	0.00	0.00	5,000.00	0.00	5,000.00	100.00
R85	Interest Revenue	0.00	0.36	1.02	-1.02	0.00	-1.02	0.00
068-0600-4850	Interest Revenue	0.00	0.36	1.02	-1.02	0.00	-1.02	0.00
	R85 Sub Totals:	0.00	0.36	1.02	-1.02	0.00	-1.02	0.00
	Revenue Sub Totals:	5,000.00	0.36	1.02	4,998.98	0.00	4,998.98	99.98
E60	Miscellaneous Expense	5,000.00	25.00	75.00	4,925.00	0.00	4,925.00	98.50
068-0600-5600	Miscellaneous Expense	5,000.00	25.00	75.00	4,925.00	0.00	4,925.00	98.50
	E60 Sub Totals:	5,000.00	25.00	75.00	4,925.00	0.00	4,925.00	98.50
	Expense Sub Totals:	5,000.00	25.00	75.00	4,925.00	0.00	4,925.00	98.50
	Dept 0600 Sub Totals:	0.00	24.64	73.98	-73.98	0.00		
	Fund Revenue Sub Totals:	5,000.00	0.36	1.02	4,998.98	0.00	4,998.98	99.98
	Fund Expense Sub Totals:	5,000.00	25.00	75.00	4,925.00	0.00	4,925.00	98.50
	Fund 068 Sub Totals:	0.00	24.64	73.98	-73.98	0.00		

Account Number	Description	Budget Amount	Period Amount	YTD Amount	YTD Var	Encumbered Amount	Available	% Available
Fund 080	Street Fund							
Dept 080-0140								
E01	Personnel Expense							
080-0140-5000	Salary Expense	82,015.23	6,266.13	21,906.96	60,108.27	0.00	60,108.27	73.29
080-0140-5010	Overtime Expense	1,000.00	0.00	0.00	1,000.00	0.00	1,000.00	100.00
080-0140-5020	FICA Expense	6,350.67	469.61	1,646.65	4,704.02	0.00	4,704.02	74.07
080-0140-5022	Unemployment Expense	1,080.00	0.00	118.32	961.68	0.00	961.68	89.04
080-0140-5025	Worker's Comp Expense	500.00	0.00	188.22	311.78	0.00	311.78	62.36
080-0140-5030	APERS Expense	12,352.67	924.89	3,233.49	9,119.18	0.00	9,119.18	73.82
080-0140-5040	Health Insurance Expense	22,700.00	1,891.64	5,674.92	17,025.08	0.00	17,025.08	75.00
080-0140-5050	Physical & Drug Screen Exp	300.00	0.00	0.00	300.00	0.00	300.00	100.00
080-0140-5055	Uniform Expense	1,200.00	386.83	630.99	569.01	0.00	569.01	47.42
080-0140-5060	Travel & Training Expense	2,600.00	345.00	345.00	2,255.00	0.00	2,255.00	86.73
E01 Sub Totals:		130,098.57	10,284.10	33,744.55	96,354.02	0.00	96,354.02	74.06
E10	Building & Grounds Exp							
080-0140-5115	Communication Exp - Telephone	700.00	0.00	27.64	672.36	53.58	618.78	88.40
080-0140-5116	Comm Exp - Cellular	1,060.00	27.69	55.38	1,004.62	0.00	1,004.62	94.78
E10 Sub Totals:		1,760.00	27.69	83.02	1,676.98	53.58	1,623.40	92.24
E20	Vehicle Expense							
080-0140-5200	Fuel Expense	6,000.00	225.05	655.02	5,344.98	0.00	5,344.98	89.08
080-0140-5210	Service & Repair - Vehicle	2,000.00	238.35	238.35	1,761.65	137.84	1,623.81	81.19
080-0140-5218	Tire Expense	1,000.00	0.00	0.00	1,000.00	0.00	1,000.00	100.00
080-0140-5225	Insurance Expense - Vehicle	1,750.00	0.00	437.50	1,312.50	0.00	1,312.50	75.00
E20 Sub Totals:		10,750.00	463.40	1,330.87	9,419.13	137.84	9,281.29	86.34
E30	Supply Expense							
080-0140-5300	Office Supplies	150.00	0.00	0.00	150.00	40.37	109.63	73.09
080-0140-5380	Prisoner Care Expense	1,500.00	0.00	0.00	1,500.00	0.00	1,500.00	100.00
E30 Sub Totals:		1,650.00	0.00	0.00	1,650.00	40.37	1,609.63	97.55
E40	Operations Expense							
080-0140-5520	Public Education Expense	1,000.00	0.00	0.00	1,000.00	0.00	1,000.00	100.00
E40 Sub Totals:		1,000.00	0.00	0.00	1,000.00	0.00	1,000.00	100.00
E55	Professional Services							
080-0140-5571	Prof Services - Engineering	0.00	0.00	0.00	0.00	0.00	0.00	0.00
080-0140-5574	Prof Services - GIS	6,120.00	0.00	0.00	6,120.00	0.00	6,120.00	100.00
080-0140-5576	Prof Services - Engineer	18,360.00	1,530.00	3,910.17	14,449.83	0.00	14,449.83	78.70
080-0140-5589	Prof Services - Printing	200.00	10.00	30.00	170.00	0.00	170.00	85.00
E55 Sub Totals:		24,680.00	1,540.00	3,940.17	20,739.83	0.00	20,739.83	84.03

Account Number	Description	Budget Amount	Period Amount	YTD Amount	YTD Var	Encumbered Amount	Available	% Available
	Expense Sub Totals:	169,938.57	12,315.19	39,098.61	130,839.96	231.79	130,608.17	76.86
Dept 080-0800	Dept 0140 Sub Totals:	169,938.57	12,315.19	39,098.61	130,839.96	231.79		
R10	Taxes - Sales							
080-0800-4152	1/2 Cent Sales Tax	275,000.00	24,773.83	79,337.29	195,662.71	0.00	195,662.71	71.15
	R10 Sub Totals:	275,000.00	24,773.83	79,337.29	195,662.71	0.00	195,662.71	71.15
R15	Taxes - Property							
080-0800-4150	State Turnback	1,080,000.00	66,459.22	191,377.10	888,622.90	0.00	888,622.90	82.28
080-0800-4151	Saline County Treasurer	380,000.00	7,706.43	27,671.69	352,328.31	0.00	352,328.31	92.72
	R15 Sub Totals:	1,460,000.00	74,165.65	219,048.79	1,240,951.21	0.00	1,240,951.21	85.00
R62	Intergovernmental Tsfrs							
080-0800-4627	Xfer Designated Tax - Street	1,073,000.00	89,416.66	268,349.98	804,650.02	0.00	804,650.02	74.99
	R62 Sub Totals:	1,073,000.00	89,416.66	268,349.98	804,650.02	0.00	804,650.02	74.99
R85	Interest Revenue							
080-0800-4850	Interest Revenue	100.00	64.86	172.46	-72.46	0.00	-72.46	0.00
	R85 Sub Totals:	100.00	64.86	172.46	-72.46	0.00	-72.46	0.00
	Revenue Sub Totals:	2,808,100.00	188,421.00	566,908.52	2,241,191.48	0.00	2,241,191.48	79.81
E01	Personnel Expense							
080-0800-5000	Salary Expense	414,241.93	32,040.63	108,811.69	305,430.24	0.00	305,430.24	73.73
080-0800-5005	SWB Reimbursement	109,000.00	18,166.66	27,249.99	81,750.01	0.00	81,750.01	75.00
080-0800-5010	Overtime Expense	15,000.00	1,462.31	4,482.73	10,517.27	0.00	10,517.27	70.12
080-0800-5020	FICA Expense	32,837.05	2,519.77	8,527.04	24,310.01	0.00	24,310.01	74.03
080-0800-5022	Unemployment Expense	5,550.00	0.00	0.00	5,550.00	0.00	5,550.00	100.00
080-0800-5025	Worker's Comp Expense	18,500.00	0.00	18,284.69	215.31	0.00	215.31	1.16
080-0800-5030	APERS Expense	63,735.26	4,945.05	16,722.35	47,012.91	0.00	47,012.91	73.76
080-0800-5040	Health Insurance Expense	94,955.04	7,924.08	23,948.61	71,006.43	0.00	71,006.43	74.78
080-0800-5050	Physical & Drug Screen Exp	2,000.00	150.00	150.00	1,850.00	0.00	1,850.00	92.50
080-0800-5055	Uniform Expense	6,000.00	403.81	515.83	5,484.17	1,297.28	4,186.89	69.78
080-0800-5060	Travel & Training Expense	3,500.00	0.00	125.00	3,375.00	220.00	3,155.00	90.14
	E01 Sub Totals:	765,319.28	67,612.31	208,817.93	556,501.35	1,517.28	554,984.07	72.52
E10	Building & Grounds Exp							
080-0800-5102	Repairs & Maint - Building	4,500.00	196.81	393.24	4,106.76	76.49	4,030.27	89.56
080-0800-5110	Utilities - Electric	16,000.00	1,362.92	3,804.30	12,195.70	0.00	12,195.70	76.22
080-0800-5111	Utilities - Gas	2,950.00	475.37	1,353.24	1,596.76	438.53	1,158.23	39.26
080-0800-5112	Utilities - Water	1,000.00	37.74	90.66	909.34	0.00	909.34	90.93

Account Number	Description	Budget Amount	Period Amount	YTD Amount	YTD Var	Encumbered Amount	Available	% Available
080-0800-5115	Communication Exp - Telephone	8,500.00	1,099.28	1,644.23	6,855.77	0.00	6,855.77	80.66
080-0800-5116	Communication Exp - Cellular	5,000.00	244.09	735.86	4,264.14	0.00	4,264.14	85.28
080-0800-5120	Insurance - Property	2,500.00	0.00	0.00	2,500.00	0.00	2,500.00	100.00
080-0800-5130	Sanitation	2,500.00	200.81	398.80	2,101.20	0.00	2,101.20	84.05
080-0800-5140	Supplies - B&G	2,600.00	338.27	338.27	2,261.73	26.21	2,235.52	85.98
080-0800-5145	Tools	10,000.00	308.03	2,086.65	7,913.35	811.02	7,102.33	71.02
E10 Sub Totals:		55,550.00	4,263.32	10,845.25	44,704.75	1,352.25	43,352.50	78.04
E20	Vehicle Expense							
080-0800-5200	Fuel Expense	70,000.00	3,795.67	9,419.25	60,580.75	904.00	59,676.75	85.25
080-0800-5210	Service & Repair - Vehicle	65,000.00	5,542.11	10,215.17	54,784.83	10,250.39	44,534.44	68.51
080-0800-5218	Tire Expense	10,000.00	0.00	1,462.07	8,537.93	0.00	8,537.93	85.38
080-0800-5225	Insurance Expense - Vehicle	13,650.00	0.00	13,641.09	8.91	0.00	8.91	0.07
080-0800-5230	Radios	1,000.00	164.25	164.25	835.75	0.00	835.75	83.58
080-0800-5240	Equipment Rental	8,000.00	0.00	0.00	8,000.00	0.00	8,000.00	100.00
E20 Sub Totals:		167,650.00	9,502.03	34,901.83	132,748.17	11,154.39	121,593.78	72.53
E30	Supply Expense							
080-0800-5300	Supplies - Office	4,000.00	573.67	1,288.50	2,711.50	548.87	2,162.63	54.07
080-0800-5316	Supplies - Signs	35,500.00	100.74	1,480.44	34,019.56	0.00	34,019.56	95.83
080-0800-5322	Supplies - Operating	4,000.00	80.39	1,444.53	3,855.47	496.92	3,358.55	83.96
080-0800-5350	Postage Expense	500.00	0.00	0.00	500.00	0.00	500.00	100.00
080-0800-5380	Prisoner Care Expense	2,000.00	102.64	102.64	1,897.36	167.67	1,729.69	86.48
E30 Sub Totals:		46,000.00	857.44	3,016.11	42,983.89	1,213.46	41,770.43	90.81
E40	Operations Expense							
080-0800-5141	Pest/Chem/Seed/Fert	2,000.00	0.00	65.70	1,934.30	0.00	1,934.30	96.72
080-0800-5142	Janitorial Supplies & Services	2,000.00	125.93	377.79	1,622.21	125.93	1,496.28	74.81
080-0800-5323	Material and Maint.	140,000.00	12,004.16	17,026.76	122,973.24	857.48	122,115.76	87.23
080-0800-5480	Dues & Subscriptions	4,400.00	0.00	0.00	4,400.00	0.00	4,400.00	100.00
080-0800-5525	Right-of-Way Maintenance	10,000.00	0.00	1,000.00	9,000.00	0.00	9,000.00	90.00
080-0800-5530	Safety Program	1,000.00	0.00	539.28	460.72	0.00	460.72	46.07
080-0800-5545	Street Paving Expense	150,000.00	2,244.02	8,407.07	141,592.93	914.34	140,678.59	93.79
080-0800-5546	Street Lights Installed	115,000.00	8,531.28	23,470.48	91,529.52	0.00	91,529.52	79.59
080-0800-5547	Traffic Signal Maintenance	25,000.00	4,706.78	5,588.31	19,411.69	0.00	19,411.69	77.65
E40 Sub Totals:		449,400.00	27,612.17	56,475.39	392,924.61	1,897.75	391,026.86	87.01
E55	Professional Services							
080-0800-5553	Prof Services - Advertising	2,500.00	0.00	176.90	2,323.10	0.00	2,323.10	92.92
080-0800-5562	Prof Services - Bridge Inspection	1,000.00	0.00	65.57	934.43	0.00	934.43	93.44
080-0800-5571	Prof Services - Engineering	12,240.00	1,020.00	3,173.22	9,066.78	0.00	9,066.78	74.08
080-0800-5574	Prof Services - GIS	6,120.00	0.00	0.00	6,120.00	0.00	6,120.00	100.00
080-0800-5586	Prof Services - Other	120,000.00	2,052.50	4,717.49	115,282.51	0.00	115,282.51	96.07
080-0800-5589	Prof Services - Printing	600.00	33.85	101.55	498.45	305.10	193.35	32.23

Account Number	Description	Budget Amount	Period Amount	YTD Amount	YTD Var	Encumbered Amount	Available	% Available
E55 Sub Totals:		142,460.00	3,106.35	8,234.73	134,225.27	305.10	133,920.17	94.01
E60	Miscellaneous Expense							
080-0800-5600	Miscellaneous Expense	5,000.00	0.00	0.00	5,000.00	0.00	5,000.00	100.00
080-0800-5604	Computer Hardware	4,000.00	0.00	0.00	4,000.00	0.00	4,000.00	100.00
080-0800-5606	Computer Maint & Support	1,000.00	260.90	260.90	739.10	91.93	647.17	64.72
080-0800-5608	Computer Software	2,500.00	0.00	0.00	2,500.00	0.00	2,500.00	100.00
E60 Sub Totals:		12,500.00	260.90	260.90	12,239.10	91.93	12,147.17	97.18
E80	Fixed Assets							
080-0800-5808	Fixed Assets - Other Equipment	371,000.00	3,959.00	3,959.00	367,041.00	29,632.75	337,408.25	90.95
080-0800-5810	Fixed Assets - Equipment	1,000.00	0.00	0.00	1,000.00	3,524.36	-2,524.36	0.00
080-0800-5828	Project - Snooks Lane	331,000.00	0.00	0.00	331,000.00	0.00	331,000.00	100.00
E80 Sub Totals:		703,000.00	3,959.00	3,959.00	699,041.00	33,157.11	665,883.89	94.72
E85	Interest Expense							
080-0800-5816	Fixed Assets - Infrastructure	0.00	0.00	0.00	0.00	0.00	0.00	0.00
E85 Sub Totals:		0.00	0.00	0.00	0.00	0.00	0.00	0.00
E90	Construction Projects							
080-0800-5904	Fixed Asse Whistling Pine Drain	210,000.00	4,933.00	4,933.00	205,067.00	0.00	205,067.00	97.65
080-0800-5910	Project - Overlay 2013	400,000.00	12,821.49	12,821.49	387,178.51	0.00	387,178.51	96.79
E90 Sub Totals:		610,000.00	17,754.49	17,754.49	592,245.51	0.00	592,245.51	97.09
Expense Sub Totals:		2,951,879.28	134,928.01	344,265.63	2,607,613.65	50,689.27	2,556,924.38	86.62
Dept 0800 Sub Totals:		143,779.28	-53,492.99	-222,642.89	366,422.17	50,689.27		
Fund Revenue Sub Totals:		2,808,100.00	188,421.00	566,908.52	2,241,191.48	0.00	2,241,191.48	79.81
Fund Expense Sub Totals:		3,121,817.85	147,243.20	383,364.24	2,738,453.61	50,921.06	2,687,532.55	86.09
Fund 080 Sub Totals:		313,717.85	-41,177.80	-183,544.28	497,262.13	50,921.06		

Account Number	Description	Budget Amount	Period Amount	YTD Amount	YTD Var	Encumbered Amount	Available	% Available
Fund 140	Park Bond 2006 DS							
Dept 140-0400	Parks General							
R10	Taxes - Sales							
140-0400-4111	Park Bond Sales Tax	960,000.00	68,137.75	240,200.16	719,799.84	0.00	719,799.84	74.98
	R10 Sub Totals:	960,000.00	68,137.75	240,200.16	719,799.84	0.00	719,799.84	74.98
R62	Intergovernmental Tsfrs							
140-0400-4626	Xfer from Other	0.00	0.02	0.04	-0.04	0.00	-0.04	0.00
	R62 Sub Totals:	0.00	0.02	0.04	-0.04	0.00	-0.04	0.00
R85	Interest Revenue							
140-0400-4850	Interest Revenue	0.00	4.42	12.33	-12.33	0.00	-12.33	0.00
140-0400-4855	Gain on Investment	0.00	0.00	0.00	0.00	0.00	0.00	0.00
	R85 Sub Totals:	0.00	4.42	12.33	-12.33	0.00	-12.33	0.00
	Revenue Sub Totals:	960,000.00	68,142.19	240,212.53	719,787.47	0.00	719,787.47	74.98
E72	Bond Expense							
140-0400-5722	Bond Principal Pmt	955,000.00	417,541.25	417,541.25	537,458.75	0.00	537,458.75	56.28
140-0400-5724	Bond Fee	5,000.00	751.50	751.50	4,248.50	0.00	4,248.50	84.97
	E72 Sub Totals:	960,000.00	418,292.75	418,292.75	541,707.25	0.00	541,707.25	56.43
E85	Interest Expense							
140-0400-5855	Loss on Investment	0.00	0.00	0.00	0.00	0.00	0.00	0.00
	E85 Sub Totals:	0.00	0.00	0.00	0.00	0.00	0.00	0.00
	Expense Sub Totals:	960,000.00	418,292.75	418,292.75	541,707.25	0.00	541,707.25	56.43
	Dept 0400 Sub Totals:	0.00	350,150.56	178,080.22	-178,080.22	0.00		
	Fund Revenue Sub Totals:	960,000.00	68,142.19	240,212.53	719,787.47	0.00	719,787.47	74.98
	Fund Expense Sub Totals:	960,000.00	418,292.75	418,292.75	541,707.25	0.00	541,707.25	56.43
	Fund 140 Sub Totals:	0.00	350,150.56	178,080.22	-178,080.22	0.00		

Account Number	Description	Budget Amount	Period Amount	YTD Amount	YTD Var	Encumbered Amount	Available	% Available
Fund 141	Park Bond 2006 DSR							
Dept 141-0400	Parks General							
R85	Interest Revenue	0.00	0.01	0.02	-0.02	0.00	-0.02	0.00
141-0400-4850	Interest Revenue	0.00	147.72	779.00	-779.00	0.00	-779.00	0.00
141-0400-4855	Gain on Investment							
	R.85 Sub Totals:	0.00	147.73	779.02	-779.02	0.00	-779.02	0.00
	Revenue Sub Totals:	0.00	147.73	779.02	-779.02	0.00	-779.02	0.00
E62	Intergovernmental Tsfr							
141-0400-5626	Xfer to Other	0.00	0.02	0.04	-0.04	0.00	-0.04	0.00
	E62 Sub Totals:	0.00	0.02	0.04	-0.04	0.00	-0.04	0.00
E85	Interest Expense							
141-0400-5855	Loss on Investment	0.00	0.00	658.92	-658.92	0.00	-658.92	0.00
	E85 Sub Totals:	0.00	0.00	658.92	-658.92	0.00	-658.92	0.00
	Expense Sub Totals:	0.00	0.02	658.96	-658.96	0.00	-658.96	0.00
	Dept 0400 Sub Totals:	0.00	-147.71	-120.06	120.06	0.00		
	Fund Revenue Sub Totals:	0.00	147.73	779.02	-779.02	0.00	-779.02	0.00
	Fund Expense Sub Totals:	0.00	0.02	658.96	-658.96	0.00	-658.96	0.00
	Fund 141 Sub Totals:	0.00	-147.71	-120.06	120.06	0.00		

Account Number	Description	Budget Amount	Period Amount	YTD Amount	YTD Var	Encumbered Amount	Available	% Available
Fund 142	Park Bond 2006 O&M							
Dept 142-0400	Parks General							
R.10	Taxes - Sales							
142-0400-4110	Park 1/8 Sales Tax	480,000.00	34,068.87	120,100.08	359,899.92	0.00	359,899.92	74.98
	R.10 Sub Totals:	480,000.00	34,068.87	120,100.08	359,899.92	0.00	359,899.92	74.98
R85	Interest Revenue							
142-0400-4850	Interest Revenue	0.00	0.08	0.60	-0.60	0.00	-0.60	0.00
142-0400-4855	Gain on Investment	0.00	0.00	0.00	0.00	0.00	0.00	0.00
	R85 Sub Totals:	0.00	0.08	0.60	-0.60	0.00	-0.60	0.00
	Revenue Sub Totals:	480,000.00	34,068.95	120,100.68	359,899.32	0.00	359,899.32	74.98
E62	Intergovernmental Tsfr							
142-0400-5626	Xfer to Other	480,000.00	34,068.87	120,100.08	359,899.92	0.00	359,899.92	74.98
	E62 Sub Totals:	480,000.00	34,068.87	120,100.08	359,899.92	0.00	359,899.92	74.98
	Expense Sub Totals:	480,000.00	34,068.87	120,100.08	359,899.92	0.00	359,899.92	74.98
	Dept 0400 Sub Totals:	0.00	-0.08	-0.60	0.60	0.00		
	Fund Revenue Sub Totals:	480,000.00	34,068.95	120,100.68	359,899.32	0.00	359,899.32	74.98
	Fund Expense Sub Totals:	480,000.00	34,068.87	120,100.08	359,899.92	0.00	359,899.92	74.98
	Fund 142 Sub Totals:	0.00	-0.08	-0.60	0.60	0.00		

Account Number	Description	Budget Amount	Period Amount	YTD Amount	YTD Var	Encumbered Amount	Available	% Available
Fund 143	Park Bond 2007 DS							
Dept 143-0400	Parks General							
R10	Taxes - Sales							
143-0400-4111	Park Bond Sales Tax	960,000.00	68,137.75	240,200.16	719,799.84	0.00	719,799.84	74.98
	R10 Sub Totals:	960,000.00	68,137.75	240,200.16	719,799.84	0.00	719,799.84	74.98
R62	Intergovernmental Tsfrs							
143-0400-4626	Xfer from Other	0.00	0.00	0.01	-0.01	0.00	-0.01	0.00
	R62 Sub Totals:	0.00	0.00	0.01	-0.01	0.00	-0.01	0.00
R85	Interest Revenue							
143-0400-4850	Interest Revenue	0.00	4.47	12.49	-12.49	0.00	-12.49	0.00
143-0400-4855	Gain on Investment	0.00	0.00	0.00	0.00	0.00	0.00	0.00
	R85 Sub Totals:	0.00	4.47	12.49	-12.49	0.00	-12.49	0.00
E72	Revenue Sub Totals:	960,000.00	68,142.22	240,212.66	719,787.34	0.00	719,787.34	74.98
	Bond Expense							
143-0400-5722	Bond Principal Pmt	955,000.00	305,988.75	305,988.75	649,011.25	0.00	649,011.25	67.96
143-0400-5724	Bond Fee	5,000.00	2,178.00	2,178.00	2,822.00	0.00	2,822.00	56.44
	E72 Sub Totals:	960,000.00	308,166.75	308,166.75	651,833.25	0.00	651,833.25	67.90
E85	Interest Expense							
143-0400-5855	Loss on Investment	0.00	0.00	0.00	0.00	0.00	0.00	0.00
	E85 Sub Totals:	0.00	0.00	0.00	0.00	0.00	0.00	0.00
	Expense Sub Totals:	960,000.00	308,166.75	308,166.75	651,833.25	0.00	651,833.25	67.90
	Dept 0400 Sub Totals:	0.00	240,024.53	67,954.09	-67,954.09	0.00		
	Fund Revenue Sub Totals:	960,000.00	68,142.22	240,212.66	719,787.34	0.00	719,787.34	74.98
	Fund Expense Sub Totals:	960,000.00	308,166.75	308,166.75	651,833.25	0.00	651,833.25	67.90
	Fund 143 Sub Totals:	0.00	240,024.53	67,954.09	-67,954.09	0.00		

Account Number	Description	Budget Amount	Period Amount	YTD Amount	YTD Var	Encumbered Amount	Available	% Available
Fund 144	Park Bond 2007 DSR							
Dept 144-0400	Parks General							
R85	Interest Revenue	0.00	0.00	0.01	-0.01	0.00	-0.01	0.00
144-0400-4850	Interest Revenue	0.00	190.44	986.10	-986.10	0.00	-986.10	0.00
144-0400-4855	Gain on Investment							
	R85 Sub Totals:	0.00	190.44	986.11	-986.11	0.00	-986.11	0.00
	Revenue Sub Totals:	0.00	190.44	986.11	-986.11	0.00	-986.11	0.00
E62	Intergovernmental Tsfr							
144-0400-5626	Xfer to Other	0.00	0.00	0.01	-0.01	0.00	-0.01	0.00
	E62 Sub Totals:	0.00	0.00	0.01	-0.01	0.00	-0.01	0.00
E85	Interest Expense							
144-0400-5855	Loss on Investment	0.00	0.00	830.06	-830.06	0.00	-830.06	0.00
	E85 Sub Totals:	0.00	0.00	830.06	-830.06	0.00	-830.06	0.00
	Expense Sub Totals:	0.00	0.00	830.07	-830.07	0.00	-830.07	0.00
	Dept 0400 Sub Totals:	0.00	-190.44	-156.04	156.04	0.00		
	Fund Revenue Sub Totals:	0.00	190.44	986.11	-986.11	0.00	-986.11	0.00
	Fund Expense Sub Totals:	0.00	0.00	830.07	-830.07	0.00	-830.07	0.00
	Fund 144 Sub Totals:	0.00	-190.44	-156.04	156.04	0.00		

Account Number	Description	Budget Amount	Period Amount	YTD Amount	YTD Var	Encumbered Amount	Available	% Available
Fund 145	Park Bond 2010 DS							
Dept 145-0400	Parks General							
R62	Intergovernmental Tsfrs							
145-0400-4627	Xfer from Other	360,000.00	0.08	60,226.93	299,773.07	0.00	299,773.07	83.27
	R62 Sub Totals:	360,000.00	0.08	60,226.93	299,773.07	0.00	299,773.07	83.27
R85	Interest Revenue							
145-0400-4850	Interest Revenue	0.00	0.85	15.43	-15.43	0.00	-15.43	0.00
	R85 Sub Totals:	0.00	0.85	15.43	-15.43	0.00	-15.43	0.00
	Revenue Sub Totals:	360,000.00	0.93	60,242.36	299,757.64	0.00	299,757.64	83.27
E72	Bond Expense							
145-0400-5722	Bond Principal Pmt	360,000.00	0.00	233,800.00	126,200.00	0.00	126,200.00	35.06
145-0400-5724	Bond Fee	0.00	0.00	2,217.50	-2,217.50	0.00	-2,217.50	0.00
	E72 Sub Totals:	360,000.00	0.00	236,017.50	123,982.50	0.00	123,982.50	34.44
E85	Interest Expense							
145-0400-5855	Loss on Investment	0.00	0.00	0.00	0.00	0.00	0.00	0.00
	E85 Sub Totals:	0.00	0.00	0.00	0.00	0.00	0.00	0.00
	Expense Sub Totals:	360,000.00	0.00	236,017.50	123,982.50	0.00	123,982.50	34.44
	Dept 0400 Sub Totals:	0.00	-0.93	175,775.14	-175,775.14	0.00		
	Fund Revenue Sub Totals:	360,000.00	0.93	60,242.36	299,757.64	0.00	299,757.64	83.27
	Fund Expense Sub Totals:	360,000.00	0.00	236,017.50	123,982.50	0.00	123,982.50	34.44
	Fund 145 Sub Totals:	0.00	-0.93	175,775.14	-175,775.14	0.00		

Account Number	Description	Budget Amount	Period Amount	YTD Amount	YTD Var	Encumbered Amount	Available	% Available
Fund 146	Park Bond 2010 DSR							
Dept 146-0400	Parks General							
R62	Intergovernmental Tsfrs							
146-0400-4627	Xfer from Other	0.00	-0.08	-0.08	0.08	0.00	0.08	0.00
	R62 Sub Totals:	0.00	-0.08	-0.08	0.08	0.00	0.08	8.00
R85	Interest Revenue							
146-0400-4850	Interest Revenue	0.00	0.03	0.12	-0.12	0.00	-0.12	0.00
146-0400-4855	Gain on Investment	0.00	269.80	365.52	-365.52	0.00	-365.52	0.00
	R85 Sub Totals:	0.00	269.83	365.64	-365.64	0.00	-365.64	0.00
	Revenue Sub Totals:	0.00	269.75	365.56	-365.56	0.00	-365.56	0.00
E62	Intergovernmental Tsfr							
146-0400-5626	Xfer to Other	0.00	0.00	904.55	-904.55	0.00	-904.55	0.00
	E62 Sub Totals:	0.00	0.00	904.55	-904.55	0.00	-904.55	0.00
E85	Interest Expense							
146-0400-5855	Loss on Investment	0.00	0.00	69.21	-69.21	0.00	-69.21	0.00
	E85 Sub Totals:	0.00	0.00	69.21	-69.21	0.00	-69.21	0.00
	Expense Sub Totals:	0.00	0.00	973.76	-973.76	0.00	-973.76	0.00
	Dept 0400 Sub Totals:	0.00	-269.75	608.20	-608.20	0.00		
	Fund Revenue Sub Totals:	0.00	269.75	365.56	-365.56	0.00	-365.56	0.00
	Fund Expense Sub Totals:	0.00	0.00	973.76	-973.76	0.00	-973.76	0.00
	Fund 146 Sub Totals:	0.00	-269.75	608.20	-608.20	0.00		

Account Number	Description	Budget Amount	Period Amount	YTD Amount	YTD Var	Encumbered Amount	Available	% Available
Fund 180	Street Bond 2008 Constr							
Dept 180-0800	Interest Revenue							
R85	Interest Revenue	0.00	2.93	8.23	-8.23	0.00	-8.23	0.00
180-0800-4850	R85 Sub Totals:	0.00	2.93	8.23	-8.23	0.00	-8.23	0.00
	Revenue Sub Totals:	0.00	2.93	8.23	-8.23	0.00	-8.23	0.00
	Dept 0800 Sub Totals:	0.00	-2.93	-8.23	8.23	0.00		
	Fund Revenue Sub Totals:	0.00	2.93	8.23	-8.23	0.00	-8.23	0.00
	Fund Expense Sub Totals:	0.00	0.00	0.00	0.00	0.00	0.00	0.00
	Fund 180 Sub Totals:	0.00	-2.93	-8.23	8.23	0.00		

Account Number	Description	Budget Amount	Period Amount	YTD Amount	YTD Var	Encumbered Amount	Available	% Available
Fund 181	Street Bond 2008 DSR							
Dept 181-0800								
R85	Interest Revenue	0.00	0.24	0.62	-0.62	0.00	-0.62	0.00
181-0800-4850	Interest Revenue	0.00	209.14	401.41	-401.41	0.00	-401.41	0.00
181-0800-4855	Gain on Investment							
	R85 Sub Totals:	0.00	209.38	402.03	-402.03	0.00	-402.03	0.00
	Revenue Sub Totals:	0.00	209.38	402.03	-402.03	0.00	-402.03	0.00
E62	Intergovernmental Tsfr							
181-0800-5626	Xfer to Other	0.00	418.63	418.63	-418.63	0.00	-418.63	0.00
	E62 Sub Totals:	0.00	418.63	418.63	-418.63	0.00	-418.63	0.00
E85	Interest Expense							
181-0800-5855	Loss on Investment	0.00	0.00	177.99	-177.99	0.00	-177.99	0.00
	E85 Sub Totals:	0.00	0.00	177.99	-177.99	0.00	-177.99	0.00
	Expense Sub Totals:	0.00	418.63	596.62	-596.62	0.00	-596.62	0.00
	Dept 0800 Sub Totals:	0.00	209.25	194.59	-194.59	0.00		
	Fund Revenue Sub Totals:	0.00	209.38	402.03	-402.03	0.00	-402.03	0.00
	Fund Expense Sub Totals:	0.00	418.63	596.62	-596.62	0.00	-596.62	0.00
	Fund 181 Sub Totals:	0.00	209.25	194.59	-194.59	0.00		

Account Number	Description	Budget Amount	Period Amount	YTD Amount	YTD Var	Encumbered Amount	Available	% Available
Fund 182	Street Bond 2008 DS							
Dept 182-0800								
R62	Intergovernmental Tsfrs							
182-0800-4623	Xfer from Other Fund	350,000.00	418.63	59,016.13	290,983.87	0.00	290,983.87	83.14
	R62 Sub Totals:	350,000.00	418.63	59,016.13	290,983.87	0.00	290,983.87	83.14
R85	Interest Revenue							
182-0800-4850	Interest Revenue	0.00	4.30	14.81	-14.81	0.00	-14.81	0.00
182-0800-4855	Gain on Investment	0.00	0.00	0.00	0.00	0.00	0.00	0.00
	R85 Sub Totals:	0.00	4.30	14.81	-14.81	0.00	-14.81	0.00
	Revenue Sub Totals:	350,000.00	422.93	59,030.94	290,969.06	0.00	290,969.06	83.13
E72	Bond Expense							
182-0800-5722	Bond Principal Pmt	350,000.00	0.00	84,292.50	265,707.50	0.00	265,707.50	75.92
182-0800-5724	Bond Fec	0.00	0.00	1,970.00	-1,970.00	0.00	-1,970.00	0.00
	E72 Sub Totals:	350,000.00	0.00	86,262.50	263,737.50	0.00	263,737.50	75.35
E85	Interest Expense							
182-0800-5855	Loss on Investment	0.00	0.00	0.00	0.00	0.00	0.00	0.00
	E85 Sub Totals:	0.00	0.00	0.00	0.00	0.00	0.00	0.00
	Expense Sub Totals:	350,000.00	0.00	86,262.50	263,737.50	0.00	263,737.50	75.35
	Dept 0800 Sub Totals:	0.00	-422.93	27,231.56	-27,231.56	0.00		
	Fund Revenue Sub Totals:	350,000.00	422.93	59,030.94	290,969.06	0.00	290,969.06	83.13
	Fund Expense Sub Totals:	350,000.00	0.00	86,262.50	263,737.50	0.00	263,737.50	75.35
	Fund 182 Sub Totals:	0.00	-422.93	27,231.56	-27,231.56	0.00		

Account Number	Description	Budget Amount	Period Amount	YTD Amount	YTD Var	Encumbered Amount	Available	% Available
Fund 500	Revenue - Water & WW							
Dept 500-0900	Water Distribution							
R50	Sale of Services		3,683.37	11,039.59	33,960.41	0.00	33,960.41	75.47
500-0900-4504	CAW Watershed	45,000.00	1,887.00	4,041.00	5,959.00	0.00	5,959.00	59.59
500-0900-4532	One Time Charge	10,000.00	11,274.39	42,619.52	82,380.48	0.00	82,380.48	65.90
500-0900-4536	Penalties	125,000.00	275.00	650.00	2,350.00	0.00	2,350.00	78.33
500-0900-4537	Insufficient Check Fee	3,000.00	750.00	2,555.50	19,444.50	0.00	19,444.50	88.38
500-0900-4540	Sales - CAW System Devel	22,000.00	2,261.10	6,774.30	23,225.70	0.00	23,225.70	77.42
500-0900-4542	Sales - FSDWA	30,000.00	6,975.00	15,536.00	54,464.00	0.00	54,464.00	77.81
500-0900-4544	Water Misc Income	70,000.00	112.50	250.00	750.00	0.00	750.00	75.00
500-0900-4548	Sales - Pump Maintenance	1,000.00	2,310.00	5,475.00	14,525.00	0.00	14,525.00	72.63
500-0900-4550	Sales - Service Charges	20,000.00	191,897.35	563,563.38	2,098,436.62	0.00	2,098,436.62	78.83
500-0900-4554	Sales - Water	2,662,000.00	980.00	4,730.00	25,270.00	0.00	25,270.00	84.23
500-0900-4556	Sales - Water Connections	30,000.00	18,202.06	53,377.42	199,622.58	0.00	199,622.58	78.90
500-0900-4560	Sales Tax Revenue	253,000.00	50.00	50.00	1,950.00	0.00	1,950.00	97.50
500-0900-4562	Swimming Pool Fill	2,000.00	222.75	675.00	1,325.00	0.00	1,325.00	66.25
500-0900-4566	Woodland Hills Watershed	2,000.00						
R50 Sub Totals:		3,275,000.00	240,880.52	711,336.71	2,563,663.29	0.00	2,563,663.29	78.28
R62	Intergovernmental Tsfrs							
500-0900-4629	Xfer to Water Impact	0.00	2,850.00	12,624.00	-12,624.00	0.00	-12,624.00	0.00
500-0900-4630	Xfer Salem Royalty	1,000.00	92.00	274.40	725.60	0.00	725.60	72.56
R62 Sub Totals:		1,000.00	2,942.00	12,898.40	-11,898.40	0.00	-11,898.40	0.00
Revenue Sub Totals:		3,276,000.00	243,822.52	724,235.11	2,551,764.89	0.00	2,551,764.89	77.89
E40	Operations Expense							
500-0900-5475	Credit Card Fees	50,000.00	4,975.60	13,202.55	36,797.45	0.00	36,797.45	73.59
E40 Sub Totals:		50,000.00	4,975.60	13,202.55	36,797.45	0.00	36,797.45	73.59
E62	Intergovernmental Tsfr							
500-0900-5624	Xfer to Water	4,612,956.35	384,413.02	1,153,239.06	3,459,717.29	3,459,717.18	0.11	0.00
500-0900-5629	Xfer to Water Impact	60,000.00	6,774.00	11,574.00	48,426.00	0.00	48,426.00	80.71
500-0900-5630	Xfer to Salem Royalty	1,000.00	90.80	276.80	723.20	0.00	723.20	72.32
500-0900-5632	Xfer to Subdivision Impact	0.00	0.00	0.00	0.00	0.00	0.00	0.00
E62 Sub Totals:		4,673,956.35	391,277.82	1,165,089.86	3,508,866.49	3,459,717.18	49,149.31	1.05
Expense Sub Totals:		4,723,956.35	396,253.42	1,178,292.41	3,545,663.94	3,459,717.18	85,946.76	1.82
Dept 0900 Sub Totals:		1,447,956.35	152,430.90	454,057.30	993,899.05	3,459,717.18		
R50	Wastewater Collection							
	Sale of Services							

Account Number	Description	Budget Amount	Period Amount	YTD Amount	YTD Var	Encumbered Amount	Available	% Available
500-0950-4552	Sales - Wastewater	3,779,000.00	319,160.15	899,107.48	2,879,892.52	0.00	2,879,892.52	76.21
500-0950-4558	Sales - WW Connections	13,000.00	900.00	1,950.00	11,050.00	0.00	11,050.00	85.00
R50 Sub Totals:		3,792,000.00	320,060.15	901,057.48	2,890,942.52	0.00	2,890,942.52	76.24
R60	Miscellaneous Revenue							
500-0950-4600	Miscellaneous Revenue	1,000.00	0.00	279.50	720.50	0.00	720.50	72.05
500-0950-4610	Ordinance Number 2013-11	0.00	0.00	0.00	0.00	0.00	0.00	0.00
R60 Sub Totals:		1,000.00	0.00	279.50	720.50	0.00	720.50	72.05
R62	Intergovernmental Tsfrs							
500-0950-4631	Xfer Wastewater Impact	0.00	3,000.00	6,500.00	-6,500.00	0.00	-6,500.00	0.00
R62 Sub Totals:		0.00	3,000.00	6,500.00	-6,500.00	0.00	-6,500.00	0.00
Revenue Sub Totals:		3,793,000.00	323,060.15	907,836.98	2,885,163.02	0.00	2,885,163.02	76.07
E62	Intergovernmental Tsfr							
500-0950-5624	Xfer to Water	4,647,447.18	387,287.26	1,161,861.78	3,485,585.40	3,485,585.34	0.06	0.00
500-0950-5631	Xfer to Wastewater Impact	44,000.00	1,500.00	5,500.00	38,500.00	0.00	38,500.00	87.50
E62 Sub Totals:		4,691,447.18	388,787.26	1,167,361.78	3,524,085.40	3,485,585.34	38,500.06	0.82
E72	Bond Expense							
500-0950-5722	Bond Principal Pmt	720,000.00	59,947.08	179,841.24	540,158.76	479,576.64	60,582.12	8.41
E72 Sub Totals:		720,000.00	59,947.08	179,841.24	540,158.76	479,576.64	60,582.12	8.41
Expense Sub Totals:		5,411,447.18	448,734.34	1,347,203.02	4,064,244.16	3,965,161.98	99,082.18	1.83
Dept 0950 Sub Totals:		1,618,447.18	125,674.19	439,366.04	1,179,081.14	3,965,161.98		
Fund Revenue Sub Totals:		7,069,000.00	566,882.67	1,632,072.09	5,436,927.91	0.00	5,436,927.91	76.91
Fund Expense Sub Totals:		10,135,403.53	844,987.76	2,525,495.43	7,609,908.10	7,424,879.16	185,028.94	1.83
Fund 500 Sub Totals:		3,066,403.53	278,105.09	893,423.34	2,172,980.19	7,424,879.16		

Account Number	Description	Budget Amount	Period Amount	YTD Amount	YTD Var	Encumbered Amount	Available	% Available
Fund 510	Water Operating							
Dept 510-0900								
R62								
510-0900-4625	Intergovernmental Tsfrs	4,416,780.35	384,413.02	1,153,239.06	3,263,541.29	0.00	3,263,541.29	73.89
	Xfer from Water	4,416,780.35	384,413.02	1,153,239.06	3,263,541.29	0.00	3,263,541.29	73.89
	R62 Sub Totals:	4,416,780.35	384,413.02	1,153,239.06	3,263,541.29	0.00	3,263,541.29	73.89
	Revenue Sub Totals:							
E01	Personnel Expense							
510-0900-5000	Salary Expense	301,208.44	22,838.11	76,495.20	224,713.24	0.00	224,713.24	74.60
510-0900-5005	SWB Reimbursement	109,000.00	18,166.66	27,249.99	81,750.01	0.00	81,750.01	75.00
510-0900-5010	Overtime Expense	18,000.00	424.41	1,583.08	16,416.92	0.00	16,416.92	91.21
510-0900-5020	FICA Expense	24,413.49	1,834.76	6,289.41	18,124.08	0.00	18,124.08	74.24
510-0900-5022	Unemployment Expense	3,345.00	0.00	137.77	3,207.23	0.00	3,207.23	95.88
510-0900-5025	Worker's Comp Expense	6,700.00	0.00	6,677.85	22.15	0.00	22.15	0.33
510-0900-5030	APERS Expense	45,667.94	3,138.57	11,584.56	34,083.38	0.00	34,083.38	74.63
510-0900-5040	Health Insurance Expense	95,274.72	5,142.31	17,159.20	78,115.52	0.00	78,115.52	81.99
510-0900-5050	Physical & Drug Screen Exp	1,500.00	0.00	0.00	1,500.00	0.00	1,500.00	100.00
510-0900-5055	Uniform Expense	4,000.00	168.83	624.05	3,375.95	489.94	2,886.01	72.15
510-0900-5060	Travel & Training Expense	6,295.00	-130.00	882.50	5,412.50	616.10	4,796.40	76.19
	E01 Sub Totals:	615,404.59	51,583.65	148,683.61	466,720.98	1,106.04	465,614.94	75.66
E10	Building & Grounds Exp							
510-0900-5102	Repairs & Maint - Building	17,500.00	2,337.12	2,825.34	14,674.66	564.25	14,110.41	80.63
510-0900-5104	Repairs & Maint - Grounds	3,600.00	0.00	0.00	3,600.00	0.00	3,600.00	100.00
510-0900-5110	Utilities - Electric	46,000.00	5,529.66	14,449.85	31,550.15	165.05	31,385.10	68.23
510-0900-5111	Utilities - Gas	2,500.00	514.89	1,060.46	1,439.54	244.37	1,195.17	47.81
510-0900-5112	Utilities - Water	500.00	9.44	36.36	463.64	0.00	463.64	92.73
510-0900-5115	Communication Exp - Telephone	11,800.00	811.28	2,110.09	9,689.91	107.16	9,582.75	81.21
510-0900-5120	Insurance - Property	14,500.00	0.00	0.00	14,500.00	0.00	14,500.00	100.00
510-0900-5130	Sanitation	12,000.00	374.08	1,647.51	10,352.49	10.79	10,341.70	86.18
510-0900-5140	Supplies - B&G	1,000.00	0.00	0.00	1,000.00	0.00	1,000.00	100.00
510-0900-5145	Tools	5,000.00	0.00	19.99	4,980.01	1,081.54	3,898.47	77.97
	E10 Sub Totals:	114,400.00	9,576.47	22,149.60	92,250.40	2,173.16	90,077.24	78.74
E20	Vehicle Expense							
510-0900-5200	Fuel Expense	30,000.00	1,647.95	4,231.77	25,768.23	0.00	25,768.23	85.89
510-0900-5210	Service & Repair - Vehicle	10,000.00	331.95	1,258.69	8,741.31	14.43	8,726.88	87.27
510-0900-5218	Tire Expense	1,500.00	0.00	0.00	1,500.00	0.00	1,500.00	100.00
510-0900-5225	Insurance Expense - Vehicle	6,000.00	0.00	4,113.97	1,886.03	0.00	1,886.03	31.43
510-0900-5240	Equipment Rental	1,000.00	0.00	0.00	1,000.00	0.00	1,000.00	100.00
	E20 Sub Totals:	48,500.00	1,979.90	9,604.43	38,895.57	14.43	38,881.14	80.17
E30	Supply Expense							

Account Number	Description	Budget Amount	Period Amount	YTD Amount	YTD Var	Encumbered Amount	Available	% Available
510-0900-5300	Supplies - Office	3,000.00	1,919.05	2,933.37	66.63	50.00	16.63	0.55
510-0900-5322	Supplies - Operating	75,000.00	10,484.28	12,144.33	62,855.67	4,230.07	58,625.60	78.17
510-0900-5324	Supplies - Chemicals	3,000.00	0.00	0.00	3,000.00	0.00	3,000.00	100.00
510-0900-5326	Supplies - Lab	500.00	0.00	0.00	500.00	0.00	500.00	100.00
510-0900-5350	Postage Expense	25,000.00	3,173.13	6,195.28	18,804.72	0.00	18,804.72	75.22
510-0900-5360	Cost of Water	1,015,000.00	66,876.13	208,099.19	806,900.81	0.00	806,900.81	79.50
	E30 Sub Totals:	1,121,500.00	82,452.59	229,372.17	892,127.83	4,280.07	887,847.76	79.17
E40	Operations Expense							
510-0900-5142	Janitorial Supplies	3,000.00	192.48	510.90	2,489.10	125.93	2,363.17	78.77
510-0900-5301	Office Equipment	2,000.00	0.00	0.00	2,000.00	0.00	2,000.00	100.00
510-0900-5475	Credit Card Processing Fee	17,500.00	1,106.37	3,286.63	14,213.37	0.00	14,213.37	81.22
510-0900-5480	Dues & Subscriptions	8,500.00	128.10	2,058.30	6,441.70	0.00	6,441.70	75.78
510-0900-5515	Permit Fee Expense	36,000.00	0.00	0.00	36,000.00	682.38	35,317.62	98.10
510-0900-5530	Safety Program	1,000.00	149.50	149.50	850.50	0.00	850.50	85.05
510-0900-5535	Sales Tax Expense	260,000.00	8,129.00	36,185.64	223,814.36	0.00	223,814.36	86.08
	E40 Sub Totals:	328,000.00	9,705.45	42,190.97	285,809.03	808.31	285,000.72	86.89
E55	Professional Services							
510-0900-5550	Prof Services - Acctg & Audit	10,000.00	0.00	0.00	10,000.00	0.00	10,000.00	100.00
510-0900-5553	Prof Services - Advertising	8,000.00	415.63	415.63	7,584.37	0.00	7,584.37	94.80
510-0900-5571	Prof Services - Engineering	9,180.00	765.00	2,663.22	6,516.78	0.00	6,516.78	70.99
510-0900-5574	Prof Services - GIS	6,120.00	0.00	0.00	6,120.00	0.00	6,120.00	100.00
510-0900-5586	Prof Services - Other	10,000.00	1,368.75	5,362.64	4,637.36	0.00	4,637.36	46.37
510-0900-5589	Prof Services - Printing	2,000.00	160.00	550.71	1,449.29	305.10	1,144.19	57.21
	E55 Sub Totals:	45,300.00	2,709.38	8,992.20	36,307.80	305.10	36,002.70	79.48
E60	Miscellaneous Expense							
510-0900-5600	Miscellaneous Expense	0.00	37.45	287.08	-287.08	0.00	-287.08	0.00
510-0900-5606	Computer Hardware	5,000.00	0.00	0.00	5,000.00	0.00	5,000.00	100.00
510-0900-5608	Computer Software Support	23,400.00	0.00	0.00	23,400.00	0.00	23,400.00	100.00
510-0900-5610	Website Expense	1,000.00	0.00	0.00	1,000.00	0.00	1,000.00	100.00
510-0900-5614	Copier Maint & Lease	4,000.00	537.80	1,586.00	2,414.00	1,911.69	502.31	12.56
	E60 Sub Totals:	33,400.00	575.25	1,873.08	31,526.92	1,911.69	29,615.23	88.67
E62	Intergovernmental Tsrfr							
510-0900-5626	Xfr Depreciation Fd - Water	90,000.00	6,446.79	18,576.81	71,423.19	0.00	71,423.19	79.36
	E62 Sub Totals:	90,000.00	6,446.79	18,576.81	71,423.19	0.00	71,423.19	79.36
E72	Bond Expense							
510-0900-5722	Bond Principal Pmt	713,176.00	20,364.49	101,822.45	611,353.55	35,130.10	576,223.45	80.80
	E72 Sub Totals:	713,176.00	20,364.49	101,822.45	611,353.55	35,130.10	576,223.45	80.80

Account Number	Description	Budget Amount	Period Amount	YTD Amount	YTD Var	Encumbered Amount	Available	% Available
E80	Fixed Assets							
510-0900-5810	Fixed Assets - Equipment	0.00	0.00	0.00	0.00	3,524.36	-3,524.36	0.00
510-0900-5816	Fixed Assets - Infrastructure	300,000.00	28,240.11	28,240.11	271,759.89	0.00	271,759.89	90.59
510-0900-5818	Meters / Boxes	23,000.00	6,343.34	7,397.28	15,602.72	14,982.67	620.05	2.70
510-0900-5819	AMI Meter Reading Expense	15,000.00	0.00	0.00	15,000.00	0.00	15,000.00	100.00
510-0900-5821	Other Equipment	335,000.00	0.00	0.00	335,000.00	0.00	335,000.00	100.00
510-0900-5822	COE Degray Project	90,000.00	0.00	0.00	90,000.00	0.00	90,000.00	100.00
510-0900-5823	COE Degray O&M	30,000.00	0.00	0.00	30,000.00	0.00	30,000.00	100.00
510-0900-5828	Project - Snooks Ln Extension	285,000.00	5,283.00	15,245.00	269,755.00	0.00	269,755.00	94.65
E80 Sub Totals:		1,078,000.00	39,866.45	50,882.39	1,027,117.61	18,507.03	1,008,610.58	93.56
E85	Interest Expense							
510-0900-5850	Interest Expense	432,572.00	14,765.59	73,827.95	358,744.05	0.00	358,744.05	82.93
E85 Sub Totals:		432,572.00	14,765.59	73,827.95	358,744.05	0.00	358,744.05	82.93
Expense Sub Totals:		4,620,252.59	240,026.01	707,975.66	3,912,276.93	64,235.93	3,848,041.00	83.29
Dept 0900 Sub Totals:		203,472.24	-144,387.01	-445,263.40	648,735.64	64,235.93		
Intergovernmental Tsfrs								
R62	Xfer from Sewer Sales	4,647,447.18	387,287.26	1,161,861.78	3,485,585.40	0.00	3,485,585.40	75.00
510-0950-4625		4,647,447.18	387,287.26	1,161,861.78	3,485,585.40	0.00	3,485,585.40	75.00
R62 Sub Totals:		4,647,447.18	387,287.26	1,161,861.78	3,485,585.40	0.00	3,485,585.40	75.00
Revenue Sub Totals:		4,647,447.18	387,287.26	1,161,861.78	3,485,585.40	0.00	3,485,585.40	75.00
E01	Personnel Expense							
510-0950-5000	Salary Expense	463,959.72	35,296.42	124,729.57	339,230.15	0.00	339,230.15	73.12
510-0950-5005	SWB Reimbursement	109,000.00	18,166.66	27,249.99	81,750.01	0.00	81,750.01	75.00
510-0950-5010	Overtime Expense	50,000.00	2,575.84	9,270.03	40,729.97	0.00	40,729.97	81.46
510-0950-5020	FICA Expense	39,317.91	2,865.20	10,085.62	29,232.29	0.00	29,232.29	74.35
510-0950-5022	Unemployment Expense	5,505.00	0.00	180.33	5,324.67	0.00	5,324.67	96.72
510-0950-5025	Worker's Comp Expense	5,500.00	0.00	5,300.56	199.44	0.00	199.44	3.63
510-0950-5030	APERS Expense	76,477.17	5,644.37	19,832.76	56,644.41	0.00	56,644.41	74.07
510-0950-5040	Health Insurance Expense	90,798.72	9,231.99	27,362.65	63,436.07	0.00	63,436.07	69.86
510-0950-5050	Physical & Drug Screen Exp	2,000.00	0.00	0.00	2,000.00	0.00	2,000.00	100.00
510-0950-5055	Uniform Expense	4,000.00	11.00	303.94	3,696.06	298.07	3,397.99	84.95
510-0950-5060	Travel & Training Expense	6,295.00	40.94	1,053.44	5,241.56	616.10	4,625.46	73.48
E01 Sub Totals:		852,853.52	73,832.42	225,368.89	627,484.63	914.17	626,570.46	73.47
E10	Building & Grounds Exp							
510-0950-5102	Repairs & Maint - Building	17,600.00	2,844.97	4,995.65	12,604.35	0.00	12,604.35	71.62
510-0950-5110	Utilities - Electric	250,000.00	19,002.10	61,752.12	188,247.88	116.94	188,130.94	75.25

Account Number	Description	Budget Amount	Period Amount	YTD Amount	YTD Var	Encumbered Amount	Available	% Available
510-0950-5111	Utilities - Gas	3,000.00	23.23	493.36	2,506.64	225.89	2,280.75	76.03
510-0950-5112	Utilities - Water	1,000.00	9.44	36.36	963.64	0.00	963.64	96.36
510-0950-5115	Communication Exp - Telephone	12,500.00	686.66	1,752.18	10,747.82	107.16	10,640.66	85.13
510-0950-5120	Insurance - Property	15,000.00	0.00	0.00	15,000.00	0.00	15,000.00	100.00
510-0950-5130	Sanitation	12,000.00	770.06	2,043.49	9,956.51	10.79	9,945.72	82.88
510-0950-5140	Supplies - B&G	1,500.00	0.00	0.00	1,500.00	0.00	1,500.00	100.00
510-0950-5145	Tools	5,500.00	0.00	19.98	5,480.02	0.00	5,480.02	99.64
	E10 Sub Totals:	318,100.00	23,336.46	71,093.14	247,006.86	460.78	246,546.08	77.51
E20	Vehicle Expense							
510-0950-5200	Fuel Expense	40,000.00	1,351.44	3,996.92	36,003.08	0.00	36,003.08	90.01
510-0950-5210	Service & Repair - Vehicle	40,000.00	2,169.17	4,793.28	35,206.72	1,812.18	33,394.54	83.49
510-0950-5218	Tire Expense	8,000.00	358.76	358.76	7,641.24	288.68	7,352.56	91.91
510-0950-5225	Insurance Expense - Vehicle	7,500.00	0.00	6,139.34	1,360.66	0.00	1,360.66	18.14
510-0950-5240	Equipment Rental	3,000.00	0.00	0.00	3,000.00	0.00	3,000.00	100.00
	E20 Sub Totals:	98,500.00	3,879.37	15,288.30	83,211.70	2,100.86	81,110.84	82.35
E30	Supply Expense							
510-0950-5223	Maintenance - Office Equipment	1,000.00	0.00	0.00	1,000.00	0.00	1,000.00	100.00
510-0950-5300	Supplies - Office	5,000.00	3,772.53	4,864.20	135.80	50.00	85.80	1.72
510-0950-5322	Supplies - Operating	156,000.00	3,010.17	7,020.12	148,979.88	3,441.89	145,537.99	93.29
510-0950-5324	Supplies - Chemicals	76,000.00	461.70	8,362.02	67,637.98	2,874.89	64,763.09	85.21
510-0950-5326	Supplies - Lab	35,000.00	980.00	980.00	34,020.00	3,370.00	30,650.00	87.57
510-0950-5350	Postage Expense	25,000.00	3,173.14	6,195.29	18,804.71	0.00	18,804.71	75.22
	E30 Sub Totals:	298,000.00	11,397.54	27,421.63	270,578.37	9,736.78	260,841.59	87.53
E40	Operations Expense							
510-0950-5142	Janitorial Supplies	1,800.00	148.11	510.87	1,289.13	125.92	1,163.21	64.62
510-0950-5475	Credit Card Processing Fee	17,500.00	1,106.38	3,286.62	14,213.38	0.00	14,213.38	81.22
510-0950-5480	Dues & Subscriptions	18,000.00	778.10	15,163.30	2,836.70	0.00	2,836.70	15.76
510-0950-5530	Safety Program	1,000.00	0.00	0.00	1,000.00	0.00	1,000.00	100.00
510-0950-5540	Equip Purchase - I & I	5,000.00	0.00	0.00	5,000.00	0.00	5,000.00	100.00
510-0950-5541	Outside Contractors- I & I	50,000.00	0.00	0.00	50,000.00	0.00	50,000.00	100.00
510-0950-5542	Service & Repair - I & I	12,000.00	275.94	275.94	11,724.06	0.00	11,724.06	97.70
	E40 Sub Totals:	105,300.00	2,308.53	19,236.73	86,063.27	125.92	85,937.35	81.61
E55	Professional Services							
510-0950-5550	Prof Services - Acctg & Audit	10,000.00	0.00	0.00	10,000.00	0.00	10,000.00	100.00
510-0950-5553	Prof Services - Advertising	8,500.00	0.00	0.00	8,500.00	0.00	8,500.00	100.00
510-0950-5571	Prof Services - Engineering	9,180.00	765.00	2,663.22	6,516.78	0.00	6,516.78	70.99
510-0950-5574	Prof Services - GIS	6,120.00	0.00	0.00	6,120.00	0.00	6,120.00	100.00
510-0950-5586	Prof Services - Other	20,000.00	1,752.50	4,287.70	15,712.30	210.69	15,501.61	77.51
510-0950-5589	Prof Services - Printing	2,000.00	160.00	480.00	1,520.00	305.10	1,214.90	60.75

Account Number	Description	Budget Amount	Period Amount	YTD Amount	YTD Var	Encumbered Amount	Available	% Available
E55 Sub Totals:		55,800.00	2,677.50	7,430.92	48,369.08	515.79	47,853.29	85.76
E60	Miscellaneous Expense							
510-0950-5606	Computer Maint & Support	42,300.00	558.45	3,498.45	38,801.55	0.00	38,801.55	91.73
510-0950-5608	Computer Software	49,800.00	0.00	0.00	49,800.00	0.00	49,800.00	100.00
510-0950-5614	Copier Maint & Lease	5,000.00	458.08	1,546.28	3,453.72	2,311.69	1,142.03	22.84
E60 Sub Totals:		97,100.00	1,016.53	5,044.73	92,055.27	2,311.69	89,743.58	92.42
E62	Intergovernmental Tsfr							
510-0950-5626	Xfer to Other	109,000.00	8,840.03	25,772.23	83,227.77	0.00	83,227.77	76.36
E62 Sub Totals:		109,000.00	8,840.03	25,772.23	83,227.77	0.00	83,227.77	76.36
E72	Bond Expense							
510-0950-5722	Bond Principal Pmt	317,242.00	0.00	0.00	317,242.00	0.00	317,242.00	100.00
E72 Sub Totals:		317,242.00	0.00	0.00	317,242.00	0.00	317,242.00	100.00
E80	Fixed Assets							
510-0950-5808	Fixed Assets - Vehicles	28,000.00	0.00	0.00	28,000.00	27,927.00	73.00	0.26
510-0950-5810	Fixed Assets - Equipment	55,000.00	4,954.55	4,954.55	50,045.45	9,037.31	41,008.14	74.56
510-0950-5816	Fixed Assets - Infrastructure	300,000.00	0.00	0.00	300,000.00	0.00	300,000.00	100.00
510-0950-5818	Meters / Boxes	23,000.00	6,343.33	7,397.27	15,602.73	14,959.89	642.84	2.79
510-0950-5819	Project - Dewatering Facility	1,432,758.00	0.00	0.00	1,432,758.00	0.00	1,432,758.00	100.00
E80 Sub Totals:		1,838,758.00	11,297.88	12,351.82	1,826,406.18	51,924.20	1,774,481.98	96.50
E85	Interest Expense							
510-0950-5850	Interest Expense	565,742.00	0.00	0.00	565,742.00	0.00	565,742.00	100.00
E85 Sub Totals:		565,742.00	0.00	0.00	565,742.00	0.00	565,742.00	100.00
Expense Sub Totals:		4,656,395.52	138,586.26	409,008.39	4,247,387.13	68,090.19	4,179,296.94	89.75
Dept 510-0970	Dept 0950 Sub Totals:	8,948.34	-248,701.00	-752,853.39	761,801.73	68,090.19		
E01	Personnel Expense							
510-0970-5000	Salary Expense	0.00	0.00	0.00	0.00	0.00	0.00	0.00
510-0970-5010	Overtime Expense	0.00	0.00	0.00	0.00	0.00	0.00	0.00
510-0970-5020	FICA Expense	0.00	0.00	0.00	0.00	0.00	0.00	0.00
510-0970-5030	APERS Expense	0.00	0.00	0.00	0.00	0.00	0.00	0.00
510-0970-5040	Health Insurance Expense	0.00	0.00	0.00	0.00	0.00	0.00	0.00
E01 Sub Totals:		0.00	0.00	0.00	0.00	0.00	0.00	0.00

Account Number	Description	Budget Amount	Period Amount	YTD Amount	YTD Var	Encumbered Amount	Available	% Available
	Expense Sub Totals:	0.00	0.00	0.00	0.00	0.00	0.00	0.00
	Dept 0970 Sub Totals:	0.00	0.00	0.00	0.00	0.00		
	Fund Revenue Sub Totals:	9,064,227.53	771,700.28	2,315,100.84	6,749,126.69	0.00	6,749,126.69	74.46
	Fund Expense Sub Totals:	9,276,648.11	378,612.27	1,116,984.05	8,159,664.06	132,326.12	8,027,337.94	86.53
	Fund 510 Sub Totals:	212,420.58	-393,088.01	-1,198,116.79	1,410,537.37	132,326.12		

Account Number	Description	Budget Amount	Period Amount	YTD Amount	YTD Var	Encumbered Amount	Available	% Available
Fund 520	Depreciation - Water							
Dept 520-0900	Intergovernmental Tsfrs							
R62	Xfer from Water	90,000.00	0.00	0.00	90,000.00	0.00	90,000.00	100.00
520-0900-4625	R62 Sub Totals:	90,000.00	0.00	0.00	90,000.00	0.00	90,000.00	100.00
R85	Interest Revenue	0.00	0.00	0.00	0.00	0.00	0.00	0.00
520-0900-4850	Interest Revenue	0.00	0.00	0.00	0.00	0.00	0.00	0.00
	R85 Sub Totals:	0.00	0.00	0.00	0.00	0.00	0.00	0.00
	Revenue Sub Totals:	90,000.00	0.00	0.00	90,000.00	0.00	90,000.00	100.00
E62	Intergovernmental Tsfr							
520-0900-5624	Xfer to Water	0.00	0.00	0.00	0.00	0.00	0.00	0.00
	E62 Sub Totals:	0.00	0.00	0.00	0.00	0.00	0.00	0.00
	Expense Sub Totals:	0.00	0.00	0.00	0.00	0.00	0.00	0.00
	Dept 0900 Sub Totals:	-90,000.00	0.00	0.00	-90,000.00	0.00		
	Fund Revenue Sub Totals:	90,000.00	0.00	0.00	90,000.00	0.00	90,000.00	100.00
	Fund Expense Sub Totals:	0.00	0.00	0.00	0.00	0.00	0.00	0.00
	Fund 520 Sub Totals:	-90,000.00	0.00	0.00	-90,000.00	0.00		

Account Number	Description	Budget Amount	Period Amount	YTD Amount	YTD Var	Encumbered Amount	Available	% Available
Fund 525	Depreciation - WW							
Dept 525-0950	Intergovernmental Tsfrs							
R62	Xfer from Water	109,000.00	15,286.82	44,349.04	64,650.96	0.00	64,650.96	59.31
525-0950-4625	R62 Sub Totals:	109,000.00	15,286.82	44,349.04	64,650.96	0.00	64,650.96	59.31
R85	Interest Revenue	0.00	-8.39	42.34	-42.34	0.00	-42.34	0.00
525-0950-4850	Interest Revenue	0.00	-8.39	42.34	-42.34	0.00	-42.34	0.00
	R85 Sub Totals:	0.00	-8.39	42.34	-42.34	0.00	-42.34	0.00
	Revenue Sub Totals:	109,000.00	15,278.43	44,391.38	64,608.62	0.00	64,608.62	59.27
E62	Intergovernmental Tsfr							
525-0950-5624	Xfer to Water	0.00	0.00	0.00	0.00	0.00	0.00	0.00
	E62 Sub Totals:	0.00	0.00	0.00	0.00	0.00	0.00	0.00
	Expense Sub Totals:	0.00	0.00	0.00	0.00	0.00	0.00	0.00
	Dept 0950 Sub Totals:	-109,000.00	-15,278.43	-44,391.38	-64,608.62	0.00		
	Fund Revenue Sub Totals:	109,000.00	15,278.43	44,391.38	64,608.62	0.00	64,608.62	59.27
	Fund Expense Sub Totals:	0.00	0.00	0.00	0.00	0.00	0.00	0.00
	Fund 525 Sub Totals:	-109,000.00	-15,278.43	-44,391.38	-64,608.62	0.00		

Account Number	Description	Budget Amount	Period Amount	YTD Amount	YTD Var	Encumbered Amount	Available	% Available
Fund 530	Sub-Div Impact Water							
Dept 530-0900	Intergovernmental Tsfrs							
R62	Xfer from Water	0.00	0.00	0.00	0.00	0.00	0.00	0.00
530-0900-4625	R62 Sub Totals:	0.00	0.00	0.00	0.00	0.00	0.00	0.00
	Interest Revenue	0.00	0.00	0.00	0.00	0.00	0.00	0.00
R85	Interest Revenue	0.00	0.00	0.00	0.00	0.00	0.00	0.00
530-0900-4850	R85 Sub Totals:	0.00	0.00	0.00	0.00	0.00	0.00	0.00
	Revenue Sub Totals:	0.00	0.00	0.00	0.00	0.00	0.00	0.00
E62	Intergovernmental Tsfr							
530-0900-5624	Xfer to Water	0.00	0.00	0.00	0.00	0.00	0.00	0.00
	E62 Sub Totals:	0.00	0.00	0.00	0.00	0.00	0.00	0.00
	Expense Sub Totals:	0.00	0.00	0.00	0.00	0.00	0.00	0.00
	Dept 0900 Sub Totals:	0.00	0.00	0.00	0.00	0.00	0.00	0.00
	Fund Revenue Sub Totals:	0.00	0.00	0.00	0.00	0.00	0.00	0.00
	Fund Expense Sub Totals:	0.00	0.00	0.00	0.00	0.00	0.00	0.00
	Fund 530 Sub Totals:	0.00	0.00	0.00	0.00	0.00	0.00	0.00

Account Number	Description	Budget Amount	Period Amount	YTD Amount	YTD Var	Encumbered Amount	Available	% Available
Fund 535	Sub-Div Impact WW							
Dept 535-0950	Intergovernmental Tsfrs							
R62	Xfer from Water	0.00	0.00	0.00	0.00	0.00	0.00	0.00
535-0950-4625	R62 Sub Totals:	0.00	0.00	0.00	0.00	0.00	0.00	0.00
	Interest Revenue	0.00	0.00	0.00	0.00	0.00	0.00	0.00
R85	Interest Revenue	0.00	0.00	0.00	0.00	0.00	0.00	0.00
535-0950-4850	R85 Sub Totals:	0.00	0.00	0.00	0.00	0.00	0.00	0.00
	Revenue Sub Totals:	0.00	0.00	0.00	0.00	0.00	0.00	0.00
E62	Intergovernmental Tsfr							
535-0950-5624	Xfer to Water	0.00	0.00	0.00	0.00	0.00	0.00	0.00
	E62 Sub Totals:	0.00	0.00	0.00	0.00	0.00	0.00	0.00
	Expense Sub Totals:	0.00	0.00	0.00	0.00	0.00	0.00	0.00
	Dept 0950 Sub Totals:	0.00	0.00	0.00	0.00	0.00	0.00	0.00
	Fund Revenue Sub Totals:	0.00	0.00	0.00	0.00	0.00	0.00	0.00
	Fund Expense Sub Totals:	0.00	0.00	0.00	0.00	0.00	0.00	0.00
	Fund 535 Sub Totals:	0.00	0.00	0.00	0.00	0.00	0.00	0.00

Account Number	Description	Budget Amount	Period Amount	YTD Amount	YTD Var	Encumbered Amount	Available	% Available
Fund 540	Fair Share							
Dept 540-0900	Intergovernmental Tsfrs							
R62	Xfer from Water	0.00	0.00	0.00	0.00	0.00	0.00	0.00
540-0900-4625	R62 Sub Totals:	0.00	0.00	0.00	0.00	0.00	0.00	0.00
R85	Interest Revenue							
540-0900-4850	Interest Revenue	0.00	0.00	0.00	0.00	0.00	0.00	0.00
	R85 Sub Totals:	0.00	0.00	0.00	0.00	0.00	0.00	0.00
	Revenue Sub Totals:	0.00	0.00	0.00	0.00	0.00	0.00	0.00
E62	Intergovernmental Tsfr							
540-0900-5624	Xfer to Water	0.00	0.00	0.00	0.00	0.00	0.00	0.00
	E62 Sub Totals:	0.00	0.00	0.00	0.00	0.00	0.00	0.00
	Expense Sub Totals:	0.00	0.00	0.00	0.00	0.00	0.00	0.00
	Dept 0900 Sub Totals:	0.00	0.00	0.00	0.00	0.00	0.00	0.00
	Fund Revenue Sub Totals:	0.00	0.00	0.00	0.00	0.00	0.00	0.00
	Fund Expense Sub Totals:	0.00	0.00	0.00	0.00	0.00	0.00	0.00
	Fund 540 Sub Totals:	0.00	0.00	0.00	0.00	0.00	0.00	0.00

Account Number	Description	Budget Amount	Period Amount	YTD Amount	YTD Var	Encumbered Amount	Available	% Available
Fund 550	Impact - Water							
Dept 550-0900	Intergovernmental Tsfrs							
R62	Xfer from Water	60,000.00	6,774.00	11,574.00	48,426.00	0.00	48,426.00	80.71
550-0900-4625	R62 Sub Totals:	60,000.00	6,774.00	11,574.00	48,426.00	0.00	48,426.00	80.71
R85	Interest Revenue							
550-0900-4850	Interest Revenue	0.00	-32.39	-23.71	23.71	0.00	23.71	0.00
	R85 Sub Totals:	0.00	-32.39	-23.71	23.71	0.00	23.71	2,371.00
	Revenue Sub Totals:	60,000.00	6,741.61	11,550.29	48,449.71	0.00	48,449.71	80.75
E62	Intergovernmental Tsfr							
550-0900-5624	Xfer to Water	0.00	0.00	0.00	0.00	0.00	0.00	0.00
	E62 Sub Totals:	0.00	0.00	0.00	0.00	0.00	0.00	0.00
	Expense Sub Totals:	0.00	0.00	0.00	0.00	0.00	0.00	0.00
	Dept 0900 Sub Totals:	-60,000.00	-6,741.61	-11,550.29	-48,449.71	0.00		
	Fund Revenue Sub Totals:	60,000.00	6,741.61	11,550.29	48,449.71	0.00	48,449.71	80.75
	Fund Expense Sub Totals:	0.00	0.00	0.00	0.00	0.00	0.00	0.00
	Fund 550 Sub Totals:	-60,000.00	-6,741.61	-11,550.29	-48,449.71	0.00		

Account Number	Description	Budget Amount	Period Amount	YTD Amount	YTD Var	Encumbered Amount	Available	% Available
Fund 555	Impact - WW							
Dept 555-0950	Intergovernmental Tsfrs							
R62	Xfer from Water	44,000.00	1,500.00	-36,750.00	80,750.00	0.00	80,750.00	183.52
555-0950-4625	R62 Sub Totals:	44,000.00	1,500.00	-36,750.00	80,750.00	0.00	80,750.00	183.52
R85	Interest Revenue	0.00	-31.30	-20.39	20.39	0.00	20.39	0.00
555-0950-4850	Interest Revenue	0.00	-31.30	-20.39	20.39	0.00	20.39	0.00
	R85 Sub Totals:	0.00	-31.30	-20.39	20.39	0.00	20.39	0.00
	Revenue Sub Totals:	44,000.00	1,468.70	-36,770.39	80,770.39	0.00	80,770.39	183.57
E62	Intergovernmental Tsfr							
555-0950-5624	Xfer to Water	0.00	0.00	0.00	0.00	0.00	0.00	0.00
	E62 Sub Totals:	0.00	0.00	0.00	0.00	0.00	0.00	0.00
	Expense Sub Totals:	0.00	0.00	0.00	0.00	0.00	0.00	0.00
	Dept 0950 Sub Totals:	-44,000.00	-1,468.70	36,770.39	-80,770.39	0.00		
	Fund Revenue Sub Totals:	44,000.00	1,468.70	-36,770.39	80,770.39	0.00	80,770.39	183.57
	Fund Expense Sub Totals:	0.00	0.00	0.00	0.00	0.00	0.00	0.00
	Fund 555 Sub Totals:	-44,000.00	-1,468.70	36,770.39	-80,770.39	0.00		

Account Number	Description	Budget Amount	Period Amount	YTD Amount	YTD Var	Encumbered Amount	Available	% Available
Fund 560	Salem Royalty							
Dept 560-0900	Intergovernmental Tsfrs							
R62	Xfer from Water	1,000.00	90.80	276.80	723.20	0.00	723.20	72.32
560-0900-4625	R62 Sub Totals:	1,000.00	90.80	276.80	723.20	0.00	723.20	72.32
R85	Interest Revenue	0.00	1.93	5.43	-5.43	0.00	-5.43	0.00
560-0900-4850	Interest Revenue	0.00	1.93	5.43	-5.43	0.00	-5.43	0.00
	R85 Sub Totals:							
	Revenue Sub Totals:	1,000.00	92.73	282.23	717.77	0.00	717.77	71.78
E60	Miscellaneous Expense							
560-0900-5602	Royalty Payment	1,000.00	83.60	259.40	740.60	0.00	740.60	74.06
	E60 Sub Totals:	1,000.00	83.60	259.40	740.60	0.00	740.60	74.06
	Expense Sub Totals:	1,000.00	83.60	259.40	740.60	0.00	740.60	74.06
	Dept 0900 Sub Totals:	0.00	-9.13	-22.83	22.83	0.00		
	Fund Revenue Sub Totals:	1,000.00	92.73	282.23	717.77	0.00	717.77	71.78
	Fund Expense Sub Totals:	1,000.00	83.60	259.40	740.60	0.00	740.60	74.06
	Fund 560 Sub Totals:	0.00	-9.13	-22.83	22.83	0.00		

Account Number	Description	Budget Amount	Period Amount	YTD Amount	YTD Var	Encumbered Amount	Available	% Available
Fund 600	W/WW Bond 2008A DS							
Dept 600-0900								
R62	Intergovernmental Tsfrs							
600-0900-4625	Xfer from Water	720,000.00	59,947.66	179,842.00	540,158.00	0.00	540,158.00	75.02
	R62 Sub Totals:	720,000.00	59,947.66	179,842.00	540,158.00	0.00	540,158.00	75.02
R85	Interest Revenue							
600-0900-4850	Interest Revenue	0.00	7.01	12.17	-12.17	0.00	-12.17	0.00
	R85 Sub Totals:	0.00	7.01	12.17	-12.17	0.00	-12.17	0.00
E72	Revenue Sub Totals:	720,000.00	59,954.67	179,854.17	540,145.83	0.00	540,145.83	75.02
	Bond Expense							
600-0900-5722	Bond Principal Pmt	405,000.00	0.00	0.00	405,000.00	0.00	405,000.00	100.00
600-0900-5724	Bond Fee	0.00	0.00	0.00	0.00	0.00	0.00	0.00
	E72 Sub Totals:	405,000.00	0.00	0.00	405,000.00	0.00	405,000.00	100.00
E85	Interest Expense							
600-0900-5850	Interest Expense	315,000.00	0.00	0.00	315,000.00	0.00	315,000.00	100.00
	E85 Sub Totals:	315,000.00	0.00	0.00	315,000.00	0.00	315,000.00	100.00
	Expense Sub Totals:	720,000.00	0.00	0.00	720,000.00	0.00	720,000.00	100.00
	Dept 0900 Sub Totals:	0.00	-59,954.67	-179,854.17	179,854.17	0.00		
	Fund Revenue Sub Totals:	720,000.00	59,954.67	179,854.17	540,145.83	0.00	540,145.83	75.02
	Fund Expense Sub Totals:	720,000.00	0.00	0.00	720,000.00	0.00	720,000.00	100.00
	Fund 600 Sub Totals:	0.00	-59,954.67	-179,854.17	179,854.17	0.00		

Account Number	Description	Budget Amount	Period Amount	YTD Amount	YTD Var	Encumbered Amount	Available	% Available
Fund 601	W/W/W Bond 2008A DSR							
Dept 601-0900								
R62	Intergovernmental Tsfrs							
601-0900-4627	Xfer from Other	0.00	0.00	0.00	0.00	0.00	0.00	0.00
	R62 Sub Totals:	0.00	0.00	0.00	0.00	0.00	0.00	0.00
R85	Interest Revenue							
601-0900-4850	Interest Revenue	0.00	0.13	0.34	-0.34	0.00	-0.34	0.00
601-0900-4855	Gain on Investment	0.00	84.90	446.21	-446.21	0.00	-446.21	0.00
	R85 Sub Totals:	0.00	85.03	446.55	-446.55	0.00	-446.55	0.00
	Revenue Sub Totals:	0.00	85.03	446.55	-446.55	0.00	-446.55	0.00
E62	Intergovernmental Tsfr							
601-0900-5626	Xfer to Other	0.00	0.26	0.34	-0.34	0.00	-0.34	0.00
	E62 Sub Totals:	0.00	0.26	0.34	-0.34	0.00	-0.34	0.00
E85	Interest Expense							
601-0900-5855	Loss on Investment	0.00	0.00	380.10	-380.10	0.00	-380.10	0.00
	E85 Sub Totals:	0.00	0.00	380.10	-380.10	0.00	-380.10	0.00
	Expense Sub Totals:	0.00	0.26	380.44	-380.44	0.00	-380.44	0.00
	Dept 0900 Sub Totals:	0.00	-84.77	-66.11	66.11	0.00		
	Fund Revenue Sub Totals:	0.00	85.03	446.55	-446.55	0.00	-446.55	0.00
	Fund Expense Sub Totals:	0.00	0.26	380.44	-380.44	0.00	-380.44	0.00
	Fund 601 Sub Totals:	0.00	-84.77	-66.11	66.11	0.00		

Account Number	Description	Budget Amount	Period Amount	YTD Amount	YTD Var	Encumbered Amount	Available	% Available
Fund 605	W/WW Bond 2008B DSR							
Dept 605-0900	Intergovernmental Tsfrs							
R62	Xfer from Other	0.00	0.00	0.00	0.00	0.00	0.00	0.00
605-0900-4627								
R62 Sub Totals:		0.00	0.00	0.00	0.00	0.00	0.00	0.00
R85	Interest Revenue	0.00	0.16	0.42	-0.42	0.00	-0.42	0.00
605-0900-4850	Interest Revenue	0.00	112.70	579.75	-579.75	0.00	-579.75	0.00
605-0900-4855	Gain on Investment							
R85 Sub Totals:		0.00	112.86	580.17	-580.17	0.00	-580.17	0.00
	Revenue Sub Totals:							
E62	Intergovernmental Tsfr	0.00	112.86	580.17	-580.17	0.00	-580.17	0.00
605-0900-5626	Xfer to Other	0.00	0.32	0.42	-0.42	0.00	-0.42	0.00
E62 Sub Totals:		0.00	0.32	0.42	-0.42	0.00	-0.42	0.00
E85	Interest Expense							
605-0900-5855	Loss on Investment	0.00	0.00	486.51	-486.51	0.00	-486.51	0.00
E85 Sub Totals:		0.00	0.00	486.51	-486.51	0.00	-486.51	0.00
	Expense Sub Totals:							
		0.00	0.32	486.93	-486.93	0.00	-486.93	0.00
	Dept 0900 Sub Totals:	0.00	-112.54	-93.24	93.24	0.00		
	Fund Revenue Sub Totals:	0.00	112.86	580.17	-580.17	0.00	-580.17	0.00
	Fund Expense Sub Totals:	0.00	0.32	486.93	-486.93	0.00	-486.93	0.00
	Fund 605 Sub Totals:	0.00	-112.54	-93.24	93.24	0.00		

Account Number	Description	Budget Amount	Period Amount	YTD Amount	YTD Var	Encumbered Amount	Available	% Available
Fund 610	Wolf Creek Debt Serv							
Dept 610-0900	Intergovernmental Tsfrs							
R62	Xfer from Other	0.00	0.00	0.00	0.00	0.00	0.00	0.00
610-0900-4626	R62 Sub Totals:	0.00	0.00	0.00	0.00	0.00	0.00	0.00
R85	Interest Revenue							
610-0900-4850	Interest Revenue	0.00	-0.04	0.02	-0.02	0.00	-0.02	0.00
	R85 Sub Totals:	0.00	-0.04	0.02	-0.02	0.00	-0.02	0.00
	Revenue Sub Totals:	0.00	-0.04	0.02	-0.02	0.00	-0.02	0.00
E60	Miscellaneous Expense							
610-0900-5723	Improvement District Payout	0.00	0.00	0.00	0.00	0.00	0.00	0.00
	E60 Sub Totals:	0.00	0.00	0.00	0.00	0.00	0.00	0.00
E72	Bond Expense							
610-0900-5722	Bond Principal Pmt	0.00	0.00	0.00	0.00	0.00	0.00	0.00
	E72 Sub Totals:	0.00	0.00	0.00	0.00	0.00	0.00	0.00
	Expense Sub Totals:	0.00	0.00	0.00	0.00	0.00	0.00	0.00
	Dept 0900 Sub Totals:	0.00	0.04	-0.02	0.02	0.00		
	Fund Revenue Sub Totals:	0.00	-0.04	0.02	-0.02	0.00	-0.02	0.00
	Fund Expense Sub Totals:	0.00	0.00	0.00	0.00	0.00	0.00	0.00
	Fund 610 Sub Totals:	0.00	0.04	-0.02	0.02	0.00		

Account Number	Description	Budget Amount	Period Amount	YTD Amount	YTD Var	Encumbered Amount	Available	% Available
Fund 611	Wolf Creek Bond							
Dept 611-0900								
R15	Taxcs - Property							
611-0900-4154	Special Assessment	0.00	0.00	0.00	0.00	0.00	0.00	0.00
	R15 Sub Totals:	0.00	0.00	0.00	0.00	0.00	0.00	0.00
R85	Interest Revenue							
611-0900-4850	Interest Revenue	0.00	0.00	0.00	0.00	0.00	0.00	0.00
	R85 Sub Totals:	0.00	0.00	0.00	0.00	0.00	0.00	0.00
	Revenue Sub Totals:	0.00	0.00	0.00	0.00	0.00	0.00	0.00
E62	Intergovernmental Trsf							
611-0900-5626	Xfer to other	0.00	0.00	0.00	0.00	0.00	0.00	0.00
	E62 Sub Totals:	0.00	0.00	0.00	0.00	0.00	0.00	0.00
E72	Bond Expense							
611-0900-5722	Bond Principal Prnt	0.00	0.00	0.00	0.00	0.00	0.00	0.00
	E72 Sub Totals:	0.00	0.00	0.00	0.00	0.00	0.00	0.00
E85	Interest Expense							
611-0900-5850	Interest Expense	0.00	0.00	0.00	0.00	0.00	0.00	0.00
	E85 Sub Totals:	0.00	0.00	0.00	0.00	0.00	0.00	0.00
	Expense Sub Totals:	0.00	0.00	0.00	0.00	0.00	0.00	0.00
	Dept 0900 Sub Totals:	0.00	0.00	0.00	0.00	0.00	0.00	0.00
	Fund Revenue Sub Totals:	0.00	0.00	0.00	0.00	0.00	0.00	0.00
	Fund Expense Sub Totals:	0.00	0.00	0.00	0.00	0.00	0.00	0.00
	Fund 611 Sub Totals:	0.00	0.00	0.00	0.00	0.00	0.00	0.00

Account Number	Description	Budget Amount	Period Amount	YTD Amount	YTD Var	Encumbered Amount	Available	% Available
Fund 615	WW Bond 2012 Constr							
Dept 615-0950	Miscellaneous Revenue							
R60	CWRLF Loan	0.00	0.00	0.00	0.00	0.00	0.00	0.00
615-0950-4610	R60 Sub Totals:	0.00	0.00	0.00	0.00	0.00	0.00	0.00
	Revenue Sub Totals:							
E80	Fixed Assets							
615-0950-5832	FA - ANRC - Pump Station 5	295,000.00	0.00	0.00	295,000.00	0.00	295,000.00	100.00
615-0950-5833	FA - ANRC - Pump Station 25	372,600.00	0.00	0.00	372,600.00	0.00	372,600.00	100.00
615-0950-5834	FA - ANRC - Dewatering Facility	668,997.00	0.00	0.00	668,997.00	0.00	668,997.00	100.00
615-0950-5835	FA - ANRC - 12" Force Main	1,365,900.00	0.00	0.00	1,365,900.00	0.00	1,365,900.00	100.00
615-0950-5836	FA - ANRC - Manhole Rehab	118,877.00	0.00	0.00	118,877.00	0.00	118,877.00	100.00
	E80 Sub Totals:	2,821,374.00	0.00	0.00	2,821,374.00	0.00	2,821,374.00	100.00
E85	Interest Expense							
615-0950-5850	Interest Expense - CWRLF	0.00	0.00	0.00	0.00	0.00	0.00	0.00
	E85 Sub Totals:	0.00	0.00	0.00	0.00	0.00	0.00	0.00
	Expense Sub Totals:	2,821,374.00	0.00	0.00	2,821,374.00	0.00	2,821,374.00	100.00
	Dept 0950 Sub Totals:	2,821,374.00	0.00	0.00	2,821,374.00	0.00	2,821,374.00	100.00
	Fund Revenue Sub Totals:	0.00	0.00	0.00	0.00	0.00	0.00	0.00
	Fund Expense Sub Totals:	2,821,374.00	0.00	0.00	2,821,374.00	0.00	2,821,374.00	100.00
	Fund 615 Sub Totals:	2,821,374.00	0.00	0.00	2,821,374.00	0.00	2,821,374.00	100.00

Account Number	Description	Budget Amount	Period Amount	YTD Amount	YTD Var	Encumbered Amount	Available	% Available
Fund 620	Water Bond 2011 Constr							
Dept 620-0900	Miscellaneous Revenue			56,439.89	-56,439.89		-56,439.89	0.00
R60	Loan - DWSRF	0.00	0.00					
620-0900-4610	R60 Sub Totals:	0.00	0.00	56,439.89	-56,439.89	0.00	-56,439.89	0.00
	Revenue Sub Totals:			56,439.89	-56,439.89			
E80	Fixed Assets							
620-0900-5816	Fixed AssetProj-16" Water Main	184,123.00	56,440.89	56,440.89	127,682.11	0.00	127,682.11	69.35
	E80 Sub Totals:	184,123.00	56,440.89	56,440.89	127,682.11	0.00	127,682.11	69.35
E85	Interest Expense							
620-0900-5850	Interest Expense - DWSRF	0.00	0.00	0.00	0.00	0.00	0.00	0.00
	E85 Sub Totals:	0.00	0.00	0.00	0.00	0.00	0.00	0.00
	Expense Sub Totals:	184,123.00	56,440.89	56,440.89	127,682.11	0.00	127,682.11	69.35
	Dept 0900 Sub Totals:	184,123.00	56,440.89	1.00	184,122.00	0.00		
	Fund Revenue Sub Totals:	0.00	0.00	56,439.89	-56,439.89	0.00	-56,439.89	0.00
	Fund Expense Sub Totals:	184,123.00	56,440.89	56,440.89	127,682.11	0.00	127,682.11	69.35
	Fund 620 Sub Totals:	184,123.00	56,440.89	1.00	184,122.00	0.00		

Account Number	Description	Budget Amount	Period Amount	YTD Amount	YTD Var	Encumbered Amount	Available	% Available
	Revenue Totals:	46,717,877.53	3,611,553.87	11,218,196.11	5,499,681.42	0.00	35,498,993.26	75.99
	Expense Totals:	52,679,259.07	3,925,152.33	10,836,474.03	1,842,785.04	8,156,738.22	33,686,046.82	63.95
	Report Totals:	5,961,381.54	313,598.46	-381,722.08	6,343,103.62	8,157,426.38		

RESOLUTION NO. 2015 _____

A RESOLUTION PROVIDING FOR THE ADOPTION OF AN AMENDED BUDGET FOR THE CITY OF BRYANT FOR THE TWELVE MONTH PERIOD BEGINNING JANUARY 1, 2015 AND ENDING DECEMBER 31, 2015

WHEREAS, the City of Bryant, Arkansas adopted a budget for The City of Bryant on December 18, 2014, recorded as Resolution 2014-31, and

WHEREAS, the City of Bryant, Arkansas, desires to amend said Budget for Fiscal Year 2015 as attached.

NOW, THEREFORE, BE IT RESOLVED BY THE CITY COUNCIL OF BRYANT, ARKANSAS THAT:

This resolution (with attachment) shall be known as the amended budget resolution for the City of

Section 1. Bryant, Arkansas, for the twelve (12) month period beginning January 1, 2015 and ending December 31, 2015.

• General Fund - Administration	(18,380)
• General Fund - Planning	(50)
• General Fund - Animal Control	(55)
• General Fund - Parks	1,185
• General Fund - Police	0
• Designated Tax Fund	288,500
• Street Fund -	161,000
• Water Operating Fund	(200,176)

Section 2. The amended general and street fund budget for the calendar year 2015 is hereby amended and adopted to read as attached.

PASSED AND APPROVED this _____ day of April, 2015.

APPROVED:

Jill Dabbs, Mayor

Approved as to Form:

ATTEST:

Sue Ashcraft, City Clerk

Richard Chris Madison, Staff Attorney



Budget Adjustment - April 2015

Account Number	Description	Original Budget	New Budget	Change in Budget
FUND 001 - General Fund				
DEPT 0100 - Administration				
001-0100-5044	Legal Services Expense	30,000.00	22,500.00	-7,500.00
001-0100-5062	Travel & Training - Mayor	3,500.00	5,500.00	2,000.00
001-0100-5104	Repairs & Maint - Grounds	1,000.00	3,200.00	2,200.00
001-0100-5146	Building & Ground Reim. Court	-24,605.00	-23,105.00	1,500.00
001-0100-5505	Mayor's Expense	5,000.00	3,000.00	-2,000.00
001-0100-5586	Prof. Services - Other	33,000.00	18,000.00	-15,000.00
001-0100-5589	Prof Services - Printing	5,000.00	5,420.00	420.00
DEPT 0100 - Administration Net Amount:				-18,380.00
DEPT 0120 -				
001-0120-5589	Prof Services - Printing	350.00	300.00	-50.00
DEPT 0120 - Planning - Net Amount:				-50.00
DEPT 0200 -				
001-0200-5589	Prof Services - Printing	500.00	445.00	-55.00
DEPT 0200 - Net Amount:				-55.00
DEPT 0410 -				
001-0410-4500	Mills Pool-Admin/Concessions	-40,000.00	-42,500.00	-2,500.00
001-0410-5104	Repairs & Maint - Grounds	9,198.00	5,198.00	-4,000.00
001-0410-5105	Repairs & Maint - Pool	0.00	2,500.00	2,500.00
DEPT 0420 -				
001-0420-5104	Building & Grounds Exp	0.00	1,500.00	1,500.00
DEPT 0430 -				
001-0430-4318	Membership 6 Mo College	-3,000.00	-1,000.00	2,000.00
001-0430-4352	Rental - Outdoor Field Fees	0.00	-2,000.00	-2,000.00
001-0430-4740	Sponsorship/Rebates	-10,000.00	-18,000.00	-8,000.00
001-0430-5104	Repairs & Maint - Grounds	37,400.00	41,400.00	4,000.00
001-0430-5330	Supplies - Park Programs	6,000.00	14,000.00	8,000.00
001-0430-5585	Prof Service - Basketball	0.00	18,000.00	18,000.00
001-0430-5586	Prof Services - Other	90,000.00	60,000.00	-30,000.00
001-0430-5587	Prof Services - Aerobic Instr	0.00	12,000.00	12,000.00
001-0430-5589	Prof Services - Printing	3,000.00	2,685.00	-315.00
DEPT Parks - Net Amount:				1,185.00
DEPT 0600 - Police				
001-0600-5840	Principal Loan - Vehicles	322,215.00	327,215.00	5,000.00
001-0600-5850	Interest Expense	16,714.00	11,714.00	-5,000.00
DEPT 0600 - Police Net Amount:				0.00

FUND 005 - Designated Tax Fund - Gen'l

005-0200-4100	Designated Tax - AC	-383,000.00	-383,500.00	-500.00
005-0400-4100	Designated Tax - Park	-383,000.00	-383,500.00	-500.00
005-0800-4100	Designated Tax - Street	-1,440,000.00	-1,150,500.00	289,500.00
FUND 005 - Designated Tax Fund - Gen'l Net Amount:				288,500.00

FUND 080 - Street Fund

080-0140-5571	Prof Services - Engineering	0.00	18,360.00	18,360.00
080-0140-5576	Prof Services - Engineer	18,360.00	0.00	-18,360.00
080-0800-5102	Repairs & Maint - Building	4,500.00	1,500.00	-3,000.00
080-0800-5810	Fixed Assets - Equipment	1,000.00	8,000.00	7,000.00
080-0800-5816	Fixed Assets - Infrastructure	0.00	367,000.00	367,000.00
080-0800-5904	Fixed AsseWhistling Pine Drain	210,000.00	0.00	-210,000.00
FUND 080 - Street Fund Net Amount:				161,000.00

FUND 510 - Water Operating

510-0900-4625	Xfer from Water	-4,416,780.35	-4,612,956.20	-196,175.85
510-0900-5102	Repairs & Maint - Building	17,500.00	8,500.00	-9,000.00
510-0900-5810	Fixed Assets - Equipment	0.00	7,000.00	7,000.00
DEPT 0900 - Net Amount:				-198,175.85

DEPT 0950 -

510-0950-5102	Repairs & Maint - Building	17,600.00	8,600.00	-9,000.00
510-0950-5810	Fixed Assets - Equipment	55,000.00	62,000.00	7,000.00
DEPT 0950 - Net Amount:				-2,000.00
FUND 510 - Water Operating Net Amount:				-200,175.85

RESOLUTION NO. 2015 _____

A RESOLUTION PROVIDING FOR THE ADOPTION OF AN AMENDED TRAVEL POLICY FOR THE CITY OF BRYANT

WHEREAS, the City of Bryant, Arkansas adopted a Travel Policy for The City of Bryant, and

WHEREAS, the City of Bryant, Arkansas, desires to amend its pesonnel handbook and replac any previous Travel Policies with this amendment;

NOW, THEREFORE, BE IT RESOLVED BY THE CITY COUNCIL OF BRYANT, ARKANSAS THAT:

Travel Policy:

Section 1. MEALS – Employees should consult the General Services Administration GSA website at <http://www.gsa.gov>

for the per-diem rate of the destination city or region. Upon submission of an advancement request using the per diem rates, on days during which an overnight stay is required, up to a maximum daily amount equal to the domestic per diem rate established by the GSA by geographic area, the City will advance employees for meals. On travel days of departure and return, the City will reimburse or advance employees at ¾ of the maximum daily rate. Receipts are not required and city credit cards may not be used for meal purchases for travel and training. Any questions regarding the applicable maximum daily meal allowance should be directed to the Finance Director before travel.

PASSED AND APPROVED this _____ day of April, 2015.

APPROVED:

Jill Dabbs, Mayor

Approved as to Form:

Richard Chris Madison, Staff Attorney

ATTEST:

Sue Ashcraft, City Clerk

ORDINANCE NO. 2015-____

**AN ORDINANCE DEFINING AND LIMITING CONDITIONS FOR OPEN BURNING
WITHIN THE CITY LIMITS OF THE CITY OF BRYANT; PROVIDING FOR
ENFORCEMENT; AND FOR OTHER PURPOSES**

WHEREAS, the City of Bryant finds it necessary to enact an ordinance to define and limit conditions for open burning within the City of Bryant; and

WHEREAS, the City of Bryant is authorized to enact and enforce laws, ordinances resolutions, rules, or regulations for the purpose of prohibiting burning in the open pursuant to Arkansas Code Annotated § 8-4-306 (b); and

WHEREAS, the City of Bryant has the responsibility and authority to abate fire hazards through regulatory mechanisms deemed necessary and appropriate under Arkansas Code Annotated § 8-6-1703(d).

THEREFORE BE IT ORDAINED, BY THE CITY COUNCIL OF THE CITY OF BRYANT, ARKANSAS THAT:

Section 1. Permissible Burning

A. Residential Vegetation Abatement

In accordance with Arkansas Code Annotated § 8-6-1703(d), instances of open burning of yard waste by residents are expressly discouraged. For the purpose of open burning, “yard waste” shall be defined as grass clippings, leaves, tree limbs and shrubbery trimmings collected by a resident or property owner from residential property located within the city limits of the City of Bryant.

1. The burning of yard waste is allowed during the following Calendar Periods:
 - a. beginning at one (1) hour before sunrise March 1 and ending at two (2) hours after sunset May 31st of each year; and
 - b. during the period beginning at one (1) hour before sunrise October 1 and ending at two (2) hours after sunset December 31st of each year.
2. The Bryant Fire Chief or designee may declare certain periods of time within the Calendar Periods listed above as “Smoke Free Periods” under the following circumstances:
 - a. Within a one-half mile radius of an outdoor public event including, but not limited to, authorized Parades, outdoor public sporting events, outdoor public gatherings such as Fall Fest, concerts, or other outdoor public assemblies including religious, civic, and community events. The intent of this provision is to protect outdoor public gatherings from the nuisance of lingering or low lying smoke coming from yard waste fires occurring within ½ mile of the outdoor public event.
 - b. When an identified outdoor public event is scheduled to occur during the Calendar Period, through either permitting with the City Parks Department, Police Department, or Code enforcement, the Fire Chief or his designee may declare a

Smoke Free Period for the duration of that scheduled event and within the ½ mile radius surrounding that event. When an event is scheduled and a determination is made to make the surrounding area “Smoke Free” the Fire Chief shall take reasonable steps to provide 48 hours advance notice on the City of Bryant website and through Notify Me.

- c. In the event of a yard waste fire occurring during the Calendar Period within a ½ mile radius of an outdoor public event, and the smoke from that yard waste fire lingers or remains low lying within the immediate area of the outdoor public event, then Fire Chief or his designee may require the extinguishment of any yard waste fire for the remainder of the outdoor event so affected by the low lying or lingering smoke.
3. Open burning of residential yard waste shall not be allowed unless the following conditions are met;
- a. Yard waste materials to be burned located on parcels of less than one (1) acre shall be placed in a pile no larger than five feet in diameter and two feet in height. No more than one pile may be burned at any given time by an individual resident or property owner.
 - b. Yard waste materials to be burned located on parcels of more than one (1) acre shall be placed in a pile no larger than six feet in diameter and three feet in height. The number of piles to be burned will not be restricted but must adhere to conditions d, e, and f.
 - c. Land Parcels of 2 acres or more are exempt from the prescribed Calendar Periods and pile size restrictions of Article 3.b. Although these parcels may burn year round they must comply with conditions of Section 1(A)(3), articles d, e, & f of this Ordinance.
 - d. Burning must be at least twenty feet from any structure, any material composed in whole or part of combustible or flammable material; any property line; or utility lines or facilities.
 - e. The fire must be attended at all times. The person attending the fire must have a charged hose (i.e. the hose must be connected to a working faucet and the water must be on and pressurized within the hose) and/or sufficient water supply or other suitable means available to completely extinguish the fire in the event that fire spread happens to occur.
 - f. Burning shall not commence until one (1) hour before sunrise, and shall be completely extinguished by two (2) hours after sunset.
 - g. For purposes of determining Land Parcel size, the Bryant Fire Chief or his designee shall use the Saline County Parcel Records accessible through www.efsedge.com/saline.

B. Burn Bans may be issued under the following circumstances

- a. Atmospheric conditions that prevent smoke from rising freely.
 - b. When excessively dry conditions exist.
 - c. Sustained winds greater than fifteen (15) mph or 13.0 Knots as measured by Saline County Automated Weather Observation System (AWOS) available at phone number 501-847-3883..
 - d. Frequent peak wind gusts greater than twenty-five (25) mph or 21.7 Knots as measured by Saline County Automated Weather Observation System (AWOS) available at phone number 501-847-3883.
1. Burn bans may be issued by:
- a. Governor
 - b. County judge
 - c. Bryant Fire Chief or designee

C. Construction or Site Improvement Burning

Open burning of trees, limbs or vegetation removed during the process of site preparation for construction or site improvement shall not be allowed unless the following conditions are met:

- a. The burning is to occur at least 20 feet from all property lines encompassing the parcel.
- b. All surface vegetation must be removed from all surface areas adjacent to the burning materials for a distance of no less than 20 feet in all directions.
- c. Approved materials to be burned may be placed in a pile no larger than 15 feet in diameter and 10 feet in height. No more than one pile may be burned at any given time by an individual resident or property owner or contractor.
- d. The fire must be checked periodically by a responsible person. The person tending the fire must have sufficient extinguishment equipment on site (tractor with blade, water truck, dozer, etc.) and available to completely extinguish/contain the fire in the event that fire spread occurs. Periodically means that a responsible person is sufficiently present to prevent the spread of the controlled fire allowed by this subsection. If fire spreads outside the area of identified and made available for burning under this subsection, then it is prima facie evidence that the fire was not being checked periodically and the land owner, contractor, and/or resident are subject to Sections 2 and 3 of this Ordinance.
- f. The parcel of real estate must be no less than one (1) acre.
- e. Notification must be given to the Bryant Fire Department at least twenty-four

hours prior to the intended burning of said trees, limbs or vegetation, by notifying the City of Bryant Public Safety Dispatch at 501-943-0865.

D. Agricultural Burning

Open burning in the course of agricultural operations (farming) shall not be allowed unless the following conditions are met:

- a. The perimeter of the parcel to be burned is tilled, disked or plowed in order to remove vegetation from the ground surface. Vegetation removal must be no less than 10 feet in width.
- b. The fire must be attended at all times.
- c. Burning shall not commence before sunrise, and shall not extend beyond sunset.

E. Other Allowed Burning

The following types of burning activities are permitted according to the circumstances listed herein:

- a. Fires of a controlled and manageable nature used in the course of food preparation that incorporate the use of barbecue equipment, outdoor fireplaces, cooking grilles, or cooking pits specifically designed and created for the preparation of food.
- b. Burning associated with road construction or right-of-way clearing operations. Any road construction or right-of-way clearing type of burning, the contractor or property owner must give notice to the Bryant Fire Department. Notification must be given to the Bryant Fire Department at least twenty-four hours prior to the intended burning of said trees, limbs or vegetation, by notifying the City of Bryant Public Safety Dispatch at 501-943-0865.
- c. Fires allowed by the Bryant Fire Department for the purpose of weed abatement, prevention and/or elimination of a fire hazards, and burning of storm debris following a disaster (City, County, State, Federal), as declared by an appropriate governmental authority, with burning of such debris at the sole discretion of the Fire Chief or his designee depending on weather, safety and environmental concerns.
- d. Instruction of fire department employees in methods of firefighting or for civil defense instruction, and under the direct supervision of the Bryant Fire Department or authorized fire training instructor.
- e. Fires associated with ceremonial (bon fire) or recreational (fireplaces, fire rings, or fire pits) purposes.
 - 1. The location of ceremonial fires shall be a minimum of 50 feet from a structure or combustible material. Approved materials to be burned shall be placed in a pile no larger than 15 feet in diameter and 10 feet in height. No more than one pile may be burned at any given time by an individual resident or property owner. Only the burning of dry and seasoned wood is permitted. The Bryant Fire Department shall inspect and approve the burn site. No permit is required.

2. The location of recreational fires shall be a minimum of 15 feet from a structure or combustible material. Approved materials to be burned shall be placed in a pile no larger than three feet in diameter and two feet in height. Only the burning of dry and seasoned wood is permitted. No permit is required.

Section 2. Prohibited Acts of Burning

The following open burning practices shall be prohibited within the corporate boundaries of the City of Bryant, Arkansas;

- a. Open burning of trash, garbage, and/or rubbish by any resident or business for the purpose of incineration.
- b. Open burning of construction waste of any kind on the premises of a construction sight.
- c. Open burning of materials resulting from remodeling, dismantling and/or demolition of structures or buildings.
- d. Open burning of vegetation clippings generated by, or resulting from, commercial activities or establishments that provide lawn maintenance and/or grounds care services through the course of normal business activities.
- e. Open burning in any right of way (ditches, alleys, street, etc.)
- f. Any burning activity when a burn ban is instituted by an appropriate governmental agency or executive as listed above.
- g. Any burning in violation of the requirements listed within this Ordinance.

Section 3. Violations and Enforcement

- a. An offender shall be issued a warning citation for a first violation of any provision of this ordinance, unless circumstances warrant more serious enforcement action as determined by the City of Bryant Fire Chief, or City of Bryant Police Chief
- b. Any person convicted of a second violation of a provision of this Ordinance, shall be fined the sum of one hundred dollars (\$100.00) plus court cost.
- c. Any person convicted of a third violation of a provision of this Ordinance within a 5 year period, shall be fined the sum of two hundred fifty dollars (\$250.00) plus court cost, and be ineligible to conduct any open burning of any type within the city boundaries of Bryant. Citations may be issued by the Bryant Police Department or authorized Fire Department personnel, who have law enforcement authority.

Section 4. Repealer Clause

All ordinances or resolutions or any parts thereof in conflict with the hereinabove are repealed to the extent of the conflict.

Section 5. Severability Clause

If any provision of this ordinance or the application thereof to any person or circumstance is held invalid, such invalidity shall not affect other provisions or applications of the ordinance which can be given effect without the invalid provision or application, and to this end the provisions of this ordinance are declared to be severable.

PASSED AND APPROVED this the _____ day of _____, 2015.

Jill Dabbs, Mayor

ATTEST:

Sue Ashcraft, City Clerk

RESOLUTION No. 2015-

A RESOLUTION REGARDING A CLASSIFICATION AND COMPENSATION PLAN FOR THE CITY OF BRYANT

WHEREAS, the City Council wishes to create an additional job position and corresponding compensation plan for said position; and

NOW, THEREFORE, BE IT RESOLVED BY THE CITY COUNCIL OF BRYANT, ARKANSAS THAT:

Section 1. The position of Parks Recreation Leader is hereby added to the City's compensation plan.

Section 2. The salary range of the Parks Recreation Leader shall be as follows, depending on experience:

Parks Recreation Leader

Minimum	Midpoint	Maximum
\$15,716	\$19,645	\$23,574

Section 3. The compensation set forth in this resolution shall henceforth be in full force and effect, subject to further revisions as may be necessary. Any revisions shall be reviewed by Human Resource Director or his/her representative and approved by the City Council before taking effect.

Section 4. In the event any title, section, paragraph, item, sentence, clause, phrase, or word of this resolution is declared or adjudged to be invalid or unconstitutional, such declaration or adjudication shall not affect the remaining portions of the resolution which shall remain in full force and effect as if the portion so declared or adjudged invalid or unconstitutional was not originally a part of the resolution.

Section 5. All resolutions and other matters in conflict with this resolution are hereby repealed to the extent of any inconsistency.

PASSED AND APPROVED this ____ day of April, 2015.

ATTEST:

Mayor Jill Dabbs

Sue Ashcraft, City Clerk

CITY OF BRYANT-2011

Parks Recreation Leader - Part-Time Proposed Job Description

Job Code: 3000
Exempt: No
Department: Parks
Reports To: Parks Program Coordinator
Location: Parks
Date Prepared: November 05, 2009
Date Revised: April 08, 2015

GENERAL DESCRIPTION OF POSITION

Plan and coordinate activities for all members of the community. Promote and ensure safety for participants.

ESSENTIAL DUTIES AND RESPONSIBILITIES

1. Plan and conduct recreational activities for community members of all ages.
2. Prepare facility (fields, rooms, etc.) for planned events.
3. Ensure facility is maintained and safe procedures are followed.
4. Advertise upcoming events.
5. Monitor recreational events.
6. Order and maintain sporting equipment (balls, bats, exercise equipment, etc.).
7. Perform clerical duties. Answer inquiries on upcoming events. Reregister participants.
8. Train staff to conduct events and safety procedures.
9. Coordinate resuscitation and first aid classes. Apply resuscitation techniques when necessary.
10. Complete reports for injury, accidents and other incidents.
11. Perform any other related duties as required or assigned.

QUALIFICATIONS

To perform this job successfully, an individual must be able to perform each essential duty mentioned satisfactorily. The requirements listed below are representative of the knowledge, skill, and/or ability required.

EDUCATION AND EXPERIENCE

Minimum requirement; general educational background without high school completion, plus 0 to 6 months related experience and/or training, and 1 to 6 months related management experience, or equivalent combination of education and experience.

COMMUNICATION SKILLS

Ability to read a limited number of words and recognize similarities and differences between words and between series of numbers; Ability to write and speak simple sentences as a means for basic communication. Ability to write reports, business correspondence, and policy/procedure manuals; Ability to effectively present information and respond to questions from groups of managers, clients, customers, and the general public.

MATHEMATICAL SKILLS

Ability to add, subtract, multiply and divide numbers. Ability to perform these mathematical skills using money and other forms of measurement.

CRITICAL THINKING SKILLS

Ability to use common sense understanding in order to carry out simple multi-step instructions. Ability to deal with standardized situations with limited variables.

REQUIRED CERTIFICATES, LICENSES, REGISTRATIONS

None

PREFERRED CERTIFICATES, LICENSES, REGISTRATIONS

None

SOFTWARE SKILLS REQUIRED

Basic: Contact Management, Database, Spreadsheet, Word Processing/Typing

INITIATIVE AND INGENUITY**SUPERVISION RECEIVED**

Under immediate supervision, with short assignments of work at frequent interval with regular check of work.

PLANNING

Limited responsibility with regard to specific assignments in planning time, method, manner, and/or sequence of performance of own work operations.

DECISION MAKING

Performs work operations which permit frequent opportunity for decision-making of minor importance and which would not only affect the operating efficiency of the individual involved, but would also affect the work operations of other employees and/or clientele to a slight degree.

MENTAL DEMAND

Slight mental demand. Operations requiring little attention and repeated successively at short intervals or non-repetitive, but of such a nature as to require little directed thinking.

ANALYTICAL ABILITY / PROBLEM SOLVING

Repetitive. Activities or duties using a pre-determined set of processes or directions coupled with nearby supervision. Learned things in situations where choice is simple or patterned.

RESPONSIBILITY FOR WORK OF OTHERS

Carries out supervisory responsibilities in accordance with the organization's policies and applicable laws. Responsibilities may include but not limited to interviewing, hiring and training employees; planning, assigning and directing work; appraising performance, rewarding and

disciplining employees; addressing complaints and resolving problems.

No supervision.

Supervises the following departments: Not indicated.

RESPONSIBILITY FOR FUNDS, PROPERTY and EQUIPMENT

No responsibility for this factor.

ACCURACY

Probable errors of internal scope readily detected in normal course of work by standard check or routine crosscheck within a single department or office. Errors resulting from inaccuracy would create minor confusion, delay or expense to correct the situation.

ACCOUNTABILITY

FREEDOM TO ACT

Established. Specific, detailed processes and instructions with immediate supervision.

ANNUAL MONETARY IMPACT

The amount of annual dollars generated based on the job's essential duties / responsibilities. Examples would include direct dollar generation, departmental budget, proper handling of organization funds, expense control, savings from new techniques or reduction in manpower.

Very small. Job creates a monetary impact for the organization up to an annual level of \$100,000.

IMPACT ON END RESULTS

Minimal impact. Job has little or no impact on the organization's end results. Job is focused on non-decision making activities or inconsequential duties.

PUBLIC CONTACT

Frequent contacts with general public, patrons, or other outside representatives, wherein the manner of handling these contacts has a bearing on the organization's position and operation.

EMPLOYEE CONTACT

Contacts occasionally with others beyond immediate associates, but generally of a routine nature. May obtain, present or discuss data, but only as pertains to an immediate and specific assignment. No responsibility for obtaining cooperation or approval of action or decision.

USE OF MACHINES, EQUIPMENT AND/OR COMPUTERS

Occasional use of non-complex machines and equipment (adding machines, calculators, copy/fax machines, etc.)

WORKING CONDITIONS

Normal working conditions as found within an office setting, wherein there is controlled temperature and a low noise level, plus a minimum of distractions.

ENVIRONMENTAL CONDITIONS

The following work environment characteristics described here are representative of those an employee encounters while performing essential functions of this job. Reasonable accommodations may be made to enable individuals with disabilities to perform the essential functions.

While performing the functions of this job, the employee is regularly exposed to outdoor weather conditions, wet or humid conditions; occasionally exposed to extreme cold, risk of electrical shock. The noise level in the work environment is usually moderate.

PHYSICAL ACTIVITIES

The following physical activities described here are representative of those that must be met by an employee to successfully perform the essential functions of this job. Reasonable accommodations may be made to enable individuals with disabilities to perform the essential functions and expectations.

High diversity, low physical. Work activities which allow for considerable amount of diversity as an incumbent performs a variety of tasks. Such tasks might be performed from a given work area, or the individual may move about physically in performing a variety of duties.

While performing the functions of this job, the employee is regularly required to stand, walk, sit, use hands to finger, handle, or feel, reach with hands and arms, climb or balance, stoop, kneel, crouch, or crawl, talk or hear, taste or smell. The employee must occasionally lift and/or move up to 50 pounds; regularly lift and/or move up to 10 pounds. Specific vision abilities required by this job include close vision; distance vision; color vision; peripheral vision; and depth perception.

ADDITIONAL INFORMATION

Not indicated.

RESOLUTION No. 2015-

A RESOLUTION REGARDING A CLASSIFICATION AND COMPENSATION PLAN FOR THE CITY OF BRYANT

WHEREAS, the City Council wishes to create an additional job position and corresponding compensation plan for said position; and

NOW, THEREFORE, BE IT RESOLVED BY THE CITY COUNCIL OF BRYANT, ARKANSAS THAT:

Section 1. The position of Parks Recreation Supervisor is hereby added to the City's compensation plan.

Section 2. The salary range of the Parks Recreation Supervisor shall be as follows, depending on experience:

Parks Recreation Supervisor

Minimum	Midpoint	Maximum
\$17,825	\$22,281	\$26,738

Section 3. The compensation set forth in this resolution shall henceforth be in full force and effect, subject to further revisions as may be necessary. Any revisions shall be reviewed by Human Resource Director or his/her representative and approved by the City Council before taking effect.

Section 4. In the event any title, section, paragraph, item, sentence, clause, phrase, or word of this resolution is declared or adjudged to be invalid or unconstitutional, such declaration or adjudication shall not affect the remaining portions of the resolution which shall remain in full force and effect as if the portion so declared or adjudged invalid or unconstitutional was not originally a part of the resolution.

Section 5. All resolutions and other matters in conflict with this resolution are hereby repealed to the extent of any inconsistency.

PASSED AND APPROVED this ____ day of April, 2015.

ATTEST:

Mayor Jill Dabbs

Sue Ashcraft, City Clerk

CITY OF BRYANT-2011

Parks Recreation Supervisor - Part-Time Proposed Job Description

Job Code: 3000
Exempt: No
Department: Parks
Reports To: Parks Program Coordinator
Location: Parks
Date Prepared: November 05, 2009
Date Revised: April 08, 2015

GENERAL DESCRIPTION OF POSITION

Plan and coordinate activities for all members of the community. Promote and ensure safety for participants.

ESSENTIAL DUTIES AND RESPONSIBILITIES

1. Plan and conduct recreational activities for community members of all ages.
2. Prepare facility (fields, rooms, etc.) for planned events.
3. Ensure facility is maintained and safe procedures are followed.
4. Advertise upcoming events.
5. Monitor recreational events.
6. Order and maintain sporting equipment (balls, bats, exercise equipment, etc.).
7. Perform clerical duties. Answer inquiries on upcoming events. Reregister participants.
8. Train staff to conduct events and safety procedures.
9. Coordinate resuscitation and first aid classes. Apply resuscitation techniques when necessary.
10. Complete reports for injury, accidents and other incidents.
11. Plan, schedule, and prepare for events.
12. Perform any other related duties as required or assigned.

QUALIFICATIONS

To perform this job successfully, an individual must be able to perform each essential duty mentioned satisfactorily. The requirements listed below are representative of the knowledge, skill, and/or ability required.

EDUCATION AND EXPERIENCE

Knowledge of a specialized field (however acquired), such as basic accounting, computer, etc. Equivalent of four years in high school, plus night, trade extension, or correspondence school

specialized training, equal to two years of college, plus 12 to 18 months related experience and/or training, and 7 to 11 months related management experience, or equivalent combination of education and experience.

COMMUNICATION SKILLS

Ability to read a limited number of words and recognize similarities and differences between words and between series of numbers; Ability to write and speak simple sentences as a means for basic communication. Ability to write reports, business correspondence, and policy/procedure manuals; Ability to effectively present information and respond to questions from groups of managers, clients, customers, and the general public.

MATHEMATICAL SKILLS

Ability to add, subtract, multiply and divide numbers. Ability to perform these mathematical skills using money and other forms of measurement.

CRITICAL THINKING SKILLS

Ability to use common sense understanding in order to carry out simple multi-step instructions. Ability to deal with standardized situations with limited variables.

REQUIRED CERTIFICATES, LICENSES, REGISTRATIONS

None

PREFERRED CERTIFICATES, LICENSES, REGISTRATIONS

None

SOFTWARE SKILLS REQUIRED

Basic: Contact Management, Database, Spreadsheet, Word Processing/Typing

INITIATIVE AND INGENUITY

SUPERVISION RECEIVED

Under immediate supervision, with short assignments of work at frequent interval with regular check of work.

PLANNING

Limited responsibility with regard to specific assignments in planning time, method, manner, and/or sequence of performance of own work operations.

DECISION MAKING

Performs work operations which permit frequent opportunity for decision-making of minor importance and which would not only affect the operating efficiency of the individual involved, but would also affect the work operations of other employees and/or clientele to a slight degree.

MENTAL DEMAND

Slight mental demand. Operations requiring little attention and repeated successively at short intervals or non-repetitive, but of such a nature as to require little directed thinking.

ANALYTICAL ABILITY / PROBLEM SOLVING

Repetitive. Activities or duties using a pre-determined set of processes or directions coupled with nearby supervision. Learned things in situations where choice is simple or patterned.

RESPONSIBILITY FOR WORK OF OTHERS

Carries out supervisory responsibilities in accordance with the organization's policies and applicable laws. Responsibilities may include but not limited to interviewing, hiring and training employees; planning, assigning and directing work; appraising performance, rewarding and disciplining employees; addressing complaints and resolving problems.

Supervises a small group (1-3) of employees in the same or lower classification. Assigns and checks work; assists and instructs as required, but performs same work as those supervised, or closely related work, most of the time. Content of the work supervised is of a non-technical nature and does not vary in complexity to any great degree.

Supervises the following departments: Recreational Leads

RESPONSIBILITY FOR FUNDS, PROPERTY and EQUIPMENT

Ordinarily has little, if any, association with funds, supplies, equipment or other property where there would exist any appreciable opportunity for damage, misappropriation, or other monetary loss.

ACCURACY

Probable errors of internal scope readily detected in normal course of work by standard check or routine crosscheck within a single department or office. Errors resulting from inaccuracy would create minor confusion, delay or expense to correct the situation.

ACCOUNTABILITY

FREEDOM TO ACT

Established. Specific, detailed processes and instructions with immediate supervision.

ANNUAL MONETARY IMPACT

The amount of annual dollars generated based on the job's essential duties / responsibilities. Examples would include direct dollar generation, departmental budget, proper handling of organization funds, expense control, savings from new techniques or reduction in manpower.

None. Job does not create any dollar monetary impact for the organization.

IMPACT ON END RESULTS

Minimal impact. Job has little or no impact on the organization's end results. Job is focused on non-decision making activities or inconsequential duties.

PUBLIC CONTACT

Frequent contacts with general public, patrons, or other outside representatives, wherein the manner of handling these contacts has a bearing on the organization's position and operation.

EMPLOYEE CONTACT

Contacts of little importance and usually with immediate associates only. Requires only ordinary courtesy to avoid friction in relationship incidental to working with others.

USE OF MACHINES, EQUIPMENT AND/OR COMPUTERS

Occasional use of non-complex machines and equipment (adding machines, calculators,

copy/fax machines, etc.)

WORKING CONDITIONS

Normal working conditions as found within an office setting, wherein there is controlled temperature and a low noise level, plus a minimum of distractions.

ENVIRONMENTAL CONDITIONS

The following work environment characteristics described here are representative of those an employee encounters while performing essential functions of this job. Reasonable accommodations may be made to enable individuals with disabilities to perform the essential functions.

While performing the functions of this job, the employee is regularly exposed to outdoor weather conditions, wet or humid conditions; occasionally exposed to extreme cold, risk of electrical shock. The noise level in the work environment is usually moderate.

PHYSICAL ACTIVITIES

The following physical activities described here are representative of those that must be met by an employee to successfully perform the essential functions of this job. Reasonable accommodations may be made to enable individuals with disabilities to perform the essential functions and expectations.

High diversity, low physical. Work activities which allow for considerable amount of diversity as an incumbent performs a variety of tasks. Such tasks might be performed from a given work area, or the individual may move about physically in performing a variety of duties.

While performing the functions of this job, the employee is regularly required to stand, walk, sit, use hands to finger, handle, or feel, reach with hands and arms, climb or balance, stoop, kneel, crouch, or crawl, talk or hear, taste or smell. The employee must occasionally lift and/or move up to 50 pounds; regularly lift and/or move up to 10 pounds. Specific vision abilities required by this job include close vision; distance vision; color vision; peripheral vision; and depth perception.

ADDITIONAL INFORMATION

Not indicated.

ORDINANCE NO. 2015-___

AN ORDINANCE AMENDING ORDINANCE NO. 2014-10 THAT AUTHORIZED THE ACQUISITION OF CERTAIN LANDS BY EMINENT DOMAIN ALONG ALCOA ROAD; DECLARING AN EMERGENCY; AND FOR OTHER PURPOSES.

WHEREAS, the City of Bryant and the Arkansas Highway Transportation Department (AHTD) have determined that the expansion of Alcoa Road is necessary for the safe and continuous flow of traffic along said highway; and

WHEREAS, it is necessary for the City of Bryant to acquire ownership of certain lands located in the vicinity of Alcoa Road for the purpose of expanding the roadway as well as connecting streets which are a part of the expansion project; and

WHEREAS, the Briggs Field Services, Inc., was retained by Saline County, City of Benton and the City of Bryant, in partnership with the Arkansas Highway and Transportation Department and Metroplan to negotiate on behalf of the Cities and County, for acquisition of Right of Ways along Alcoa Road;

WHEREAS, Briggs Field Services, Inc., has indicated that it is not possible to acquire the property necessary through negotiation and purchase; and

WHEREAS, the Briggs Field Services, Inc., has provided a list of properties and property owners whom the city should exercise its right of eminent domain for the construction project; and

WHEREAS, Briggs Field Services, Inc., provided an incorrect property description that was included in Ordinance No. 2014-10, duly passed on June 10, 2014; and

WHEREAS, the appraisal provided by Briggs Field Services included lands that were not property described in the property description provided to the City of Bryant from Briggs Field Service, Inc.; and

WHEREAS, the property description included in Ordinance No. 2014-10 Attachment "D" described the property as being 28,406 square feet, more or less; and

WHEREAS, the appraisal and price paid into the Circuit Clerk of Saline County as part of the legal process to take ex-parte possession of the property was based upon total square footage of 29,024, more or less; and

WHEREAS, it is necessary to amend Ordinance No. 2014-10 to provide and correct the inaccurate property description; and

WHEREAS, the City Council of the City of Bryant has determined that amendment of Ordinance No. 2014-10 is proper and necessary for the continued growth and safety of citizens of Bryant; and

WHEREAS, the City Council of the City of Bryant desires to authorize the use of eminent domain on the heretofore described properties.

NOW, THEREFORE, BE IT ORDAINED BY THE CITY COUNCIL OF THE CITY OF BRYANT, ARKANSAS:

Section 1: Ordinance No. 2014-10, Attachment "D" is stricken in its entirety and replaced with the following:

ATTACHMENT "D"

*Tract 65 The Boone Trust, Dated 12/22/97
 5900 Boone Road
 Bryant, AR 72022-9729*

LEGAL DESCRIPTION

Part of the Southwest Quarter of the Southwest Quarter of Section 29, Township 1 South, Range 14 West, Saline County, Arkansas being more particularly described as follows:

Commencing at a ¾ inch pipe being used as the Southeast corner of the Southeast Quarter of the Southwest Quarter of Section 29; thence North 89° 14' 12" West along the South line thereof a distance of 1,333.88 feet to a point being used as the Southeast corner of the Southwest Quarter of the Southwest Quarter of Section 29; thence North 89° 14' 12" West along the South line thereof a distance of 1,235.55 feet to a point on the East right of way line of Alcoa Road as established by AHTD Job 061267 for the POINT OF BEGINNING; thence continuing North 89° 14' 12" West along said South line a distance of 30.02 to a point, thence continuing North 89° 14' 12" West along said South line a distance of 29.29 feet to a point on the East right of way line of Alcoa Road as established by AHTD Job C-62-4; thence North 3° 03' 29" East along said right of way line a distance of 255.81 feet to a point; thence North 1° 52' 14" East along said right of way line a distance of 562.25 feet to a point; thence South 88° 49' 00" East a distance of 92.83 feet to a point on the East right of way line of Alcoa Road as established by AHTD Job 061297; thence South 1° 47' 55" West along said right of way line a distance of 52.06 feet to point; thence South 22° 04' 53" West along said right of way line a distance

of 49.04 feet to a point; thence South 60° 50' 06" West along said right of way line a distance of 34.99 feet to a point; thence South 28° 31' 43" West along said right of way line a distance of 48.91 feet to a point; thence South 1° 47' 55" West along said right of way line a distance of 179.31 feet to a point; thence South 1° 03' 04" West along said right of way line a distance of 150.17 feet to a point; thence South 2° 17' 28" West along said right of way line a distance of 288.04 feet to a point; thence South 34° 18' 23" East along said right of way line a distance of 50.34 feet to the POINT OF BEGINNING and containing 0.67 acres, more or less, or 29,024 square feet, more or less.

SECTION 2: The remainder of Ordinance No. 2014-10 remains unchanged. The City of Bryant has already deposited such sums as necessary to take possession of the described lands as amended by this Ordinance. This amendment is necessary only to clarify a scrivener's error in the description of the property. The Mayor is directed to cause such filings as are necessary with the Saline County Circuit Court as may be necessary to amend the complaint for eminent domain and to take such actions as are necessary to correct the inaccurate property description that was provided by Briggs Field Service, Inc., and to seek an Order of the Court for possession of the lands as described by this Amendment.

SECTION 3: EMERGENCY CLAUSE:

It is hereby found and determined that the immediate passage of this Ordinance is necessary for the immediate correction to the described lands and to maintain the construction time table for the Alcoa Road project as utility relocation is beginning, and that taking of the property as properly described above and being necessary for the immediate preservation of public health, safety and welfare; THEREFORE, an emergency is hereby declared to exist and this Ordinance shall be in full force and effect from and after its passage and approval.

PASSED AND APPROVED this the _____ day of _____, 2015.

Jill Dabbs, Mayor

Sue Ashcraft, City Clerk

ORDINANCE NO.: 2015-_____

AN ORDINANCE DEFINING THE DUTIES AND RESPONSIBILITIES OF THE ELECTED CITY ATTORNEY FOR THE CITY OF BRYANT, ARKANSAS

WHEREAS, The City of Bryant has defined the duties of the Elected City Attorney, via Ordinance No. 2005-33, duly adopted by the City Council and taking effect on January 1, 2006;

WHEREAS, The City of Bryant, has since that time employed a full-time staff attorney and contracted with other attorneys to provide the duties identified in Ordinance No. 2005-33;

WHEREAS, The City of Bryant wishes to repeal Ordinance No. 2005-33 and replace it with the following list of duties and responsibilities for the Elected City Attorney for the City of Bryant, Arkansas.

NOW, THEREFORE, BE IT ORDAINED BY THE CITY COUNCIL OF THE CITY OF BRYANT, SALINE COUNTY, ARKANSAS:

Section 1: Definition of Duties.

The Elected City Attorney shall be responsible for prosecuting alleged violations of civil and criminal City of Bryant code violations occurring within the corporate limits of the City of Bryant, and shall prosecute all misdemeanor criminal violations occurring within the corporate limits of the City of Bryant, including appeals. The Elected City Attorney may not have to prosecute cases appealed to the Saline County Circuit Court if the Saline County Prosecuting Attorney's office elects to process any appeals of criminal violation convictions resulting from the Saline County District Court- Bryant Division. These duties are on a part-time basis for the City of Bryant. The Elected City Attorney may maintain a private practice that does not conflict with his duties assigned herein. The Elected City attorney shall not perform, nor has any responsibility for or supervision of any of the duties delegated or assigned to the City of Bryant staff attorney as described within the staff attorney's job description.

Section 2: Annual Salary.

The salary for the Elected City Attorney shall be \$30,000 per year (\$2500.00 per month).

Section 3: Severability and General Repealer.

All ordinances and part of ordinances of a permanent and general nature in effect at the time of adoption of this ordinance and not included herein, are hereby repealed where they are in conflict with this ordinance.

Section 4: Emergency Clause.

That whereas this Ordinance is necessary to preserve the public peace, health, safety and welfare, an emergency is declared to exist and this Ordinance shall be in full force and effect from and after the date of its passage.

PASSED AND APPROVED THIS _____ DAY OF _____, 2015, BY THE CITY COUNCIL OF BRYANT, ARKANSAS.

Jill Dabbs, Mayor

Attest:

Sue Ashcraft, City Clerk

Bryant Parks and Recreation Department 2014 Program Agreement

THIS AGREEMENT made and entered into on _____, **2015** by and between the CITY OF BRYANT PARKS AND RECREATION DEPARTMENT, doing business at 6401 Boone Road, Bryant, Arkansas (hereinafter called "THE CITY"), and Bryant Barracudas, doing business at 690 W. Lawson RD Alexander, Arkansas (hereinafter called "BB").

WITNESSETH

WHEREAS, THE CITY maintains property at Bishop Park Aquatic Center in Bryant, Arkansas; and

WHEREAS, the use of said property for the purpose of the Bryant Barracudas Swim Team has been considered the best use of this property for recreational purpose and to better service the citizens of Bryant, Arkansas.

WHEREAS, THE CITY provides and maintains certain recreational facilities for programs and parks in Bryant, and

WHEREAS, Bryant Barracudas provides program administration and operations of the Swim Program in Bryant, NOW, THEREFORE, in consideration of mutual covenants and promises set forth herein, the parties agree as follows:

THE CITY agrees to grant use of Bishop Park Aquatic Center between **May 4th, 2015 – July 19, 2015** and Mills Park Pool between **June 8th - July 19th** as outlined here to BB for the operation of Bryant Barracudas.

Named property will be used by BB for events, and practices on the dates and times listed on the schedules provided to THE DEPARTMENT.

The general conditions of this program agreement will be:

1. BB will operate programs in accordance with nondiscrimination requirements of *Title VI* of the 1964 Civil Rights Act.
2. It is further agreed that program personnel must adhere to all provisions of the Americans with Disabilities Act (ADA) that apply to a particular program.
3. Program personnel and participants agree to abide by all Federal, State, and Local laws in addition to the policies of THE CITY pertaining to parks and facilities.
4. It is understood that THE CITY will not be liable for any injuries incurred by participants who are participating in activities on or in THE DEPARTMENT's Facility. BB shall indemnify and hold the City of Bryant, its departments and all of its employees, and agents harmless against losses, claims, causes of action and liabilities on account of damage to property or injury to or death of persons arising out of negligent acts by BB, its agents, employees, or program participants.
5. It is agreed that the named facility, area, or property may not be assigned, subleased, rented, reserved or loaned to any other group, business, individual, or entity by BB without prior approval by THE CITY.

6. No alterations, changes, or modifications to change the intended use may be made to facilities by BB, without first receiving written approval from THE CITY. The BB must submit a detailed request in writing to THE CITY'S Park Department (hereinafter, "THE DEPARTMENT").

7. BB assumes full responsibility and liability for damage caused by participants of their programs. Any damage caused will be fixed by BB. If the repair is neglected for a long period of time THE CITY will make the necessary repairs and bill the BB.

8. BB must inspect facilities prior to each use. If damage is discovered to equipment or a facility that poses an immediate hazard or danger BB must immediately notify THE DEPARTMENT. Damaged equipment or facilities that do not pose a danger or hazard should be discussed with THE DEPARTMENT. BB must report any vandalism or theft to THE DEPARTMENT within 24 (twenty-four) hours or next business day.

9. With this agreement, BB agrees to pay the charge of Summer Swim League fee, \$1,750.00.

10. The team roster must be turned in 10 day prior to the practice start date. Roster must include Name, Last Name, and DOB, home address and phone number, emergency contact name, address and phone number. Any changes to roster must be reported to the Aquatics Coordinator.

11. Bishop Park Pool Practice Schedule

May 4th – June 5th;

Barracuda	MTWTR	4-445pm	Lanes 8,7,6
Barracuda	MW	730-8:15pm	Lanes 8,7,6
Barracuda	TTR	630-8pm	Lanes 8,7,6
Barracuda	TTR	730-815pm	Lanes 3,4,5

June 8th – July 19th;

Barracuda	MTWTRF	10-11:30am	Lanes 8,7,6,5
Barracuda	MWF	7-830am	Lanes 8,7,6,5
Barracuda	MTWTR	7:30-9:00pm	Lanes 8,7,6,5

Mills Park Pool Practice Schedule

June 1st – July 19th;

Monday through Thursday 7:00pm-8:00pm.

Monday through Friday 7:00-8:00am.

12. BB agrees to use Mills Park Pool outside of regular operation hours. Therefore BB is responsible closing up the facility and following closing procedures provided by THE CITY.

13. THE CITY will not provide lifeguards for Bishop Park and Mills Park Pool practices. BB is responsible providing necessary supervision for practices.

14. BB agrees to use only the Bishop Park Competition Pool with no more than four (4) lanes

during the provided practice times.

15. BB will be allowed to host 3 swim meets for six (6) hours limit on each meet for no charge. BB agrees to pay \$100.00 for every hour exceeding six (6) hours.

16. BB will NOT have an access to the timing system, starting system, and the scoreboard for the duration of the swim meets. Advertising on scoreboard, and hanging sponsor banners and signs requires an approval from the Department.

17. In order to participate on the Bryant Barracuda Swim Team and in its practices or meets, Bryant Barracuda Swim Team swimmers will not be required to be members of Bishop Park Community Center. However, swimmers who are not members may not under any circumstances be in the aquatic facility without a coach or teacher present and supervising them. When practice ends, all non-members must leave before the coach or teacher leaves.

18. BB agrees to provide a volunteer for each practice to make sure every Bryant Barracudas Swim Team member uses the facility for ONLY the practice hours provided by The Department. The Department is not responsible for any injuries or accidents at any time. Proof of insurance must be turned in with the roster.

19. Additional swim meets will be charged. The competition pool fee is \$100.00/hour; therapy pool usage fee is \$100/hour. The meet schedule must be turned in with this agreement. Dates and times must not conflict with THE DEPARTMENT work schedule without prior approval. Normal work hours for THE DEPARTMENT are: 8:00 AM - 5:00 PM Monday - Friday.

20. The Department has the first option to run the concession during those meets.

21. If requested by the Bryant Parks and Recreation Committee or City Council, BB agrees to provide a financial statement of the program(s) that this program agreement is written for, if requested in writing separately of this agreement.

22. BB agrees to return this agreement signed by the appropriate persons, and any and all additional requested material before the May 4th 2015.

23. Additional conditions to be agreed upon not previously listed:

A. BB will control all litter by picking up litter their program creates after each time the facility is used. The litter must be placed in the proper receptacle by BB.

B. BB will provide proper insurance for the programs they will be operating on city property. Proof of insurance must be attached to this program agreement before regular season starts. BB understands that their program participants are in no way covered by insurance by THE CITY OR THE DEPARTMENT.

C. BB will submit contact person(s) for after business hours emergencies. List responsibility of person submitted.

D. At the request of THE DEPARTMENT, BB will remove all their equipment at the

completion of this agreement period.

E. BB will insure that their employees or participants do not attempt to operate equipment belonging to THE DEPARTMENT.

24. THE DEPARTMENT agrees to the following specific conditions and assurances:

A. The Aquatic Center area will be maintained on a regular schedule.

B. THE DEPARTMENT will be responsible Monday - Sunday for the pool chemicals.

C. THE DEPARTMENT will purchase and replace light bulbs. If extensive damage is caused by weather or vandalism, the replacement time for lights may be longer than usual.

D. THE DEPARTMENT will attempt to repair damage to facilities in a timely manner, according to repairs needed.

E. THE DEPARTMENT upon written request by the BB will provide a liaison to the BB meetings to assure the maintenance program is satisfactory.

F. Permanent improvements to facilities and fields will become property of THE DEPARTMENT.

G. Non-permanent improvements will be retained by BB.

The term of this Agreement shall be one (1) year, and shall begin on the first day of the month in which this Agreement is executed by the parties. This Agreement shall automatically be renewed for like terms of one (1) year each successively until this Agreement is terminated, unless a party gives ninety (90) days' notice, in advance of the termination date, of its intention to not renew.

Bryant Parks and Recreation Department, or Bryant Barracudas may amend this agreement by the mutual assent of both parties. If this agreement is amended, it will be written, signed by both parties stated and attached to this original agreement.

IN WITNESS WHEREOF the parties hereto have caused this Agreement to be executed in their behalf on BB; and supersede any and/or all previous agreements, contracts, or leases.

CITY OF BRYANT,

A municipal Corporation, First Party,

_____, Mayor

User Organization,

Dated this ____ day of _____, 2015

BRYANT PARKS AND RECREATION

PARTNERSHIP AGREEMENT

This Agreement entered into this ____ day of _____, 20__, by and between CITY OF BRYANT AND ITS PARK AND RECREATION DEPARTMENT, hereinafter referred to as “Bryant,” and _____, hereinafter referred to as “Tenant,” hereby agree as follows:

1. Terms and Conditions - Under the terms and conditions herein set forth, Bryant grants vendor rights to the Tenant as stipulated in Attachment A.

2. Payment - Payments shall be made to the order of BRYANT PARK AND RECREATION as follows:

A check or cash payment of \$__ must be made prior to Tenant opening for each business day at said location(s). Payments must be made to a Bryant staff member at either Mills Park Pool Concessions or Bishop Park Reception.

3. Term of Agreement - This Agreement and the granting of vendor services, limited to shaved ice products only, hereunder shall be for an initial term beginning on __June 6, 2015__ and ending on __August 16, 2015__ at the designated space authorized by Bryant in Mills Park Pool Parking Lot located at 1003 Mills Park Road in Bryant, Arkansas.

4. Assignment - This agreement shall not be assigned by the Tenant, nor shall Tenant grant any other person any of its rights without prior consent of Bryant.

5. Hold Harmless and Indemnification - Tenant agrees to hold harmless and indemnify Bryant, its officers, agents and employees, from and against any and all actions, suits, damages, liability or other proceedings which may arise as the result of performing services hereunder. This section does not require Tenant to be responsible for or defend against any claims or damages arising solely from acts or omissions of Bryant, its officers, agents, or employees.

6. Applicable Law - This Agreement shall be governed by the laws of the State of Arkansas. Saline County Circuit Court shall be the sole court with jurisdiction over any matter arising from this agreement. If any provision of this Agreement is or becomes unenforceable, the other provisions shall remain valid and enforceable to the maximum extent possible.

7. Nondiscrimination - It is mutually agreed that there shall be no discrimination on the basis of a person's race, color, creed, religion, national origin, ancestry, citizenship, gender, sexual orientation, age or disability.

8. Default – At any time, either party may terminate this contract by giving a three (3) day notice to corresponding party. All parties' rights under this Section are in addition to, and are not a limitation on or in substitution for, any other rights which either party has by reason of any non-performance, including, without limitation, any claim for damages under law of equity. All rights are cumulative. Upon termination, all rights and obligations of the parties under this Agreement shall cease. Time is of the essence in the performance of all duties and obligations imposed by this Agreement. Each parties' course of dealing, or forbearance from, or delay in, the exercise of any of their rights, remedies, privileges or right to insist upon strict performance of any provisions contained in this Agreement, shall not be construed as a waiver by either party, unless any such waiver is in writing and is signed by the party. Written notice shall be mailed to the addresses and persons identified by their execution of this agreement below.

To the City of Bryant:

Office of the Mayor of the City of Bryant
c/o Notification of Default per written contract
Address: 210 S.W. 3rd Street
City, State, Zip: Bryant, Arkansas 72022

To _____:

???

???

???

On this day and year first above written, the parties hereto have executed this Agreement.¹

Name of Company and President

¹ An Original Executed Copy must be filed with the City Clerk for the City of Bryant, with copies to Parks and Finance Department.

Address: _____

City, State, Zip: _____

Phone: _____

Fax: _____

Email: _____

Authorized Signature and Title

Date

CITY OF BRYANT

Mayor Jill Dabbs

Address: 210 S.W. 3rd Street

City, State, Zip: Bryant, Arkansas 72022

Phone : 501-943-0444

Fax: 501-943-0048

Email: bgriffin@cityofbryant.com

Mayordabbs@cityofbryant.com

Authorized Signature and Title

Date

ATTACHMENT A
TERMS AND CONDITIONS

1. Bryant leases to the Tenant and the Tenant rents from Bryant the following described premises: Parking lot space for a 7*12 concession trailer as well as 15' x 15' space for tables and chairs as provided by the Tenant (if necessary).
2. The term of the lease shall commence June 6, 2015 and end August 16, 2015.
3. The Tenant shall pay Bryant \$_____ each day prior to opening for business.
4. The Tenant may only open for business during Mills Park Pool hours of operation (Monday thru Thursday 9am-7pm, Friday 9am-6pm, Saturday & Sunday 12pm-6pm).
5. The Tenant shall not make any alterations, additions, or improvements to the premises without the prior written consent of Bryant.
6. The Tenant must furnish their own utilities including: Water, Waste and Electricity. Use of Bryant utilities will result in a \$25 utility fee each day paid in addition to leasing fee.
7. The Tenant shall not commit waste to the premises.
8. The Tenant shall comply with rules, regulations, ordinance codes and laws of all government authorities having jurisdiction over the premises.
9. The tenant shall not permit or engage in any activity that will effect an increase in the rate of insurance for Bryant nor shall the Tenant permit or commit any nuisance therein.
10. The Tenant shall not sublet or assign the premises nor allow any other person or business to use or occupy the premises without prior written consent of Bryant, which consent may not be unreasonably held.
11. The Tenant agrees to maintain a \$1,000,000 liability insurance policy for the duration of the lease.
12. At the end of the leasing agreement, the Tenant shall surrender and deliver up the premises in the same condition (subject to any additions, alterations or improvements, if any) as presently exists, reasonable wear and tear included.
13. Upon default in any term or condition of this Lease, Bryant shall have the right to undertake any or all other remedies permitted by law.
14. This Lease shall be binding upon, and inure to the benefit of, the parties, their heirs, successors, and assigns.

RESOLUTION No. 2015- _____

**A RESOLUTION EXPRESSING THE WILLINGNESS OF CITY OF BRYANT
TO UTILIZE FEDERAL-AID RECREATIONAL TRAILS FUND**

WHEREAS, the City Council of the City of Bryant understands Federal-aid Recreation Trails Funds are available at 80% federal participation and 20% local match/in kind labor to develop or improve Mills Park Trail Resurfacing; and

WHEREAS, the City Council of the City of Bryant understands that Federal-aid Funds are available for this project on a reimbursable basis, requiring work to be accomplished and proof of payment prior to actual monetary reimbursement, and

WHEREAS, this project, using federal funding, will be open and available for use by the general public and maintained by the applicant for the life of the project.

NOW, THEREFORE, BE IT RESOLVED BY THE CITY COUNCIL OF BRYANT, ARKANSAS THAT:

Section 1. The City Council of the City of Bryant will participate in accordance with its designated responsibility, including maintenance of this project.

Section 2. The Mayor and the City Clerk are hereby authorized and directed to execute all appropriate agreements and contracts necessary to expedite the construction of the above stated project.

Section 3. The City Council of the City of Bryant pledges its full support and hereby authorizes the Arkansas State Highway and Transportation Department to initiate action to implement this project.

PASSED AND APPROVED this ____ day of _____, 2015.

APPROVED:

Jill Dabbs, Mayor

ATTEST:

Sue Ashcraft, City Clerk

ORDINANCE NO. 2015-____

AN ORDINANCE AMENDING ORDINANCE NOS.: 2000-30 AND 1998-17 REGARDING PERMISSIBLE POSSESSION AND CONSUMPTION OF ALCOHOL IN DESIGNATED AND PERMITTED AREAS WITHIN CERTAIN CITY PARKS; AND FOR OTHER PURPOSES

WHEREAS, The City of Bryant owns and operates park facilities within the City of Bryant; and

WHEREAS, Ordinance Nos. 2000-30 and 1998-17 have declared it unlawful for a person to linger or remain in a city park for the purpose of consuming or distributing alcoholic beverages, and/or to possess alcoholic beverages in a city park; and

WHEREAS, These Ordinances were written at a time when the sale of alcoholic beverages was prohibited in Saline County; and

WHEREAS, Saline County has voted to change the prohibitions on alcohol within its boundaries and now allows the sale of alcohol within the requirements of the Alcohol Beverage Control Division of the Arkansas Department of Finance and Administration; and

WHEREAS, The City Council of the City of Bryant has determined that allowing consumption of alcohol at certain city parks under permitted and within designated locations is beneficial to the economic competitiveness of the City of Bryant Park Department to attract events and assist local events; and

WHEREAS, The City Council of the City of Bryant has determined that Ordinance Nos.: 2000-30 and 1998-17 should be amended to allow alcohol within designated areas within certain city parks as allowed and defined by City of Bryant Parks Department Policies and approved permitting procedures.

THEREFORE BE IT ORDAINED, BY THE CITY COUNCIL OF THE CITY OF BRYANT, ARKANSAS THAT:

Section 1. Ordinance Nos. 2000-30 and 1998-17 shall be amended as follows:

SECTION FIVE: It shall be unlawful for any person to:

- 1. Linger or remain in a park for the purpose of engaging in any sexual activity;*
- 2. Linger or remain in a park for the purpose of buying, distributing or using any controlled substance;*
- 3. Linger or remain in an area not designated and properly Permitted by the City of Bryant Parks Department for an approved event for the purpose of consuming or distributing alcoholic beverages;*

4. *Possess any alcoholic beverages in a city park other than in designated areas under properly Permitted events and following the terms and conditions of the City of Bryant Parks Department Polices.*
5. *Possess any handgun, knife or club on or about his person or in a vehicle occupied by him otherwise readily available with the purpose to employ as a weapon;*
6. *Park a vehicle in any area other than that designated for vehicular parking;*
7. *Operate any motorized vehicle except in area designated for such use; or*
8. *Operate any all-terrain vehicle in any area within a city park, except that such all-terrain vehicles may be used for work purposes if prior approval is obtained from the Parks Director.*

Section 2. Repealer Clause

All ordinances or resolutions or any parts thereof in conflict with the hereinabove are repealed to the extent of the conflict.

Section 3. Severability Clause

If any provision of this ordinance or the application thereof to any person or circumstance is held invalid, such invalidity shall not affect other provisions or applications of the ordinance which can be given effect without the invalid provision or application, and to this end the provisions of this ordinance are declared to be severable.

PASSED AND APPROVED this the _____ day of _____, 2015.

Jill Dabbs, Mayor

ATTEST:

Sue Ashcraft, City Clerk



DO NOT PROMOTE YOUR EVENT BEFORE RECEIVING TENTATIVE APPROVAL FROM THE CITY OF BRYANT!

City of Bryant, Parks and Recreation Department
SPECIAL EVENT APPLICATION

This Box for Office Use Only
Date Received:

Return to: Bryant Parks Department
6401 Boone Road
Bryant, AR 72022

Phone: (501) 943-0444

City Ordinance(TBD) requires this fully completed application and signed indemnification agreement to be submitted to the City of Bryant Parks Department at least 45 DAYS PRIOR to the first day of the event. Sorry, facsimiles cannot be accepted! Any misrepresentation in this application or deviation from the final agreed upon route and/or method of operation described herein, may result in the immediate revocation of the permit. Please type or print information clearly and attach additional sheets as necessary. PLEASE CALL (501) 943-0444 IF YOU NEED ASSISTANCE COMPLETING THIS FORM!

EVENT INFORMATION

Event Name:

Event Type: (Check all that apply)
Concert, Exhibition, Protest, Run, Dance, Festival, Race, Walk, Drama, Parade, Ride, Other (Specify)

Table with 4 columns: Date (MM/DD/YY), Day of Week, Start Time, End Time. Rows for Day 1, Day 2, Day 3.

Event Location:

Event Purpose:

City facilities to be used: Park, Room, Other (please specify):

If your event is in a City park, have you completed a Parks Rules and regulation form? No, Yes Date Submitted:

Table with 3 columns: Street, Street, Street. Rows for Streets Affected.

Anticipated Crowd Size: Number of Support/volunteer personnel:

Has this event been produced previously? Any changes from previous event(s)? If "yes" please note the

Is there an admission fee? No, Yes If Yes, what is the fee? \$
Will there be any vending? No, Yes Check all that apply: Food/Beverage, Souvenirs/Clothing

Will alcohol be sold or otherwise dispensed? ** No, Yes If Yes, is a copy of your ABC application attached? No, Yes

- **IF ALCOHOL IS TO BE SOLD OR OTHERWISE DISPENSED, YOU MUST INCLUDE THE FOLLOWING ITEMS WITH THIS APPLICATION:
1. A COPY of your Division of Alcoholic Beverage Control of the State of Arkansas (ABC) permit application.
2. A written plan detailing how you intend to keep minors from obtaining alcohol served at the event. (See sample form pg5)
3. A written plan detailing how you intend to keep participants from bringing their own alcohol to the event. (See sample form pg5)
4. All permit balances must be paid in full 14 days prior to the event date
5. Alcohol sells must cease one hour before the event ends or by 12:00am the following midnight.

THIS EVENT APPLICATION MUST BE SUBMITTED AT LEAST 45 DAYS IN ADVANCE OF THE EVENT.

APPLICANT INFORMATION

Organization name: _____		<input type="checkbox"/> For Profit
Address: _____		<input type="checkbox"/> Non-Profit

City: _____ **State:** _____ **Zip Code:** _____

Phone: () _____ **Mobile:** () _____ **e-mail:** _____

Event Contact: _____

Address: _____

City: _____ **State:** _____ **Zip Code:** _____

Phone: () _____ **Mobile:** () _____ **e-mail:** _____

Other Contact: _____

Address: _____

City: _____ **State:** _____ **Zip Code:** _____

Phone: () _____ **Mobile:** () _____ **e-mail:** _____

Security Coordinator: _____

Address: _____

City: _____ **State:** _____ **Zip Code:** _____

Phone: () _____ **Mobile:** () _____ **e-mail:** _____

OTHER EVENT INFORMATION

Will animals be allowed at the event? No Yes Species: _____ Estimated Number: _____

Who is responsible for removing animal excrement? _____ Phone: () _____

Who will be responsible for after-event cleanup/trash removal? _____ Phone: () _____

Will separate receptacles be in place at this event for recycling? No Yes **THE CITY OF BRYANT WANTS YOU TO RECYCLE!**

Will fireworks be a part of the event? No Yes **Note: State and City permits must be obtained before event permit is issued!**

What pyrotechnic company is doing fireworks for the event? _____ Phone: () _____

How many flush toilets will be available? _____ How many portable restrooms will be in place? _____ **See attached chart for help.**

What is your electric source? Existing Source Temporary Pole Portable Generator++ No Electricity Needed

What electric contractor will be on hand for this event? _____ Phone: () _____

Is amplified sound planned? ++ No Yes If "Yes" what purpose? Public Address Music/Entertainment

++ Loud generators, amplified sound and other noise may violate the City's Noise Ordinance (2005-05) if the volume is such to disturb other dwellings, businesses or persons in the vicinity. Event promoters must ensure sound is kept below disturbing levels. LEGITIMATE NOISE COMPLAINTS MAY CAUSE THE IMMEDIATE REVOCATION OF THE EVENT PERMIT!

Briefly note your plans for providing:

1. Hand washing facilities for vendors/guests: _____
2. Handicapped restroom facilities: _____
3. Trash receptacles: _____
4. Recycling receptacles: _____
5. Removal of animal feces: _____
6. After-event cleanup: _____

**EVENT APPLICATIONS MUST INCLUDE A DETAILED
DIAGRAM OF THE EVENT AREA OR ROUTE**

EVENT SAFETY PLAN

How many law enforcement officers will provide event security? _____

How many law enforcement officers will provide traffic control? _____

How many licensed private security officers will be on hand for this event? _____

How many volunteer security monitors will be on hand for this event? _____

How many paramedics will be on hand for this event? _____

How many first responders will be on hand for this event? _____

SECURITY EXPENSES
All security expenses,
including law enforcement
personnel expenses
must be paid
by the event sponsor

NEED HELP DETERMINING PUBLIC SAFETY NEEDS? CALL (501)943-0943

Briefly note what you believe to be the major security and traffic control issues with your event:

The City of Bryant Special Events Ordinance requires the permittee/sponsoring organization to provide adequate security personnel as determined by the Chief of Police. Public safety needs are determined by evaluation of anticipated crowd size, similar event history and event type. For assistance, call (501)943-0943.

All parade, athletic event, or other special event costs, including but not limited to, costs for cleanup, repair, fire services and police services shall be borne by the applicant.

List planned parking locations for spectators, vendors and staff:

Spectator Parking: _____

Handicapped Parking _____

Vendor Parking: _____

Staff Parking: _____

REQUIRED INSURANCE INFORMATION

Evidence of insurance must be provided to the Parks Director no less than five (5) days prior to the event. **The City of Bryant at 210 SW 3rd St, Bryant, AR 72022, must be named "additional insured" to all coverage.** Notation of certificate will not be accepted! Surplus line policies must be issued and stamped in the State of Arkansas.

Minimum Limits as applicable:

\$250,000 each person **bodily injury** (\$300,000 minimum if the event is in a city park)

\$500,000 each occurrence **property damage** or

\$500,000 each occurrence combined single limit **bodily injury and property damage.**

If food or non-alcoholic beverages are to be sold or served, the policy must include a minimum \$250,000 endorsement for **product liability.**

If alcoholic beverages are to be sold or served, the policy must include a \$500,000 **liquor legal liability** endorsement.

A SPECIAL EVENT PERMIT CANNOT BE ISSUED UNTIL INSURANCE HAS BEEN SUBMITTED!

City of Bryant

Special Event Indemnification Agreement

In consideration of the issuance of a special events permit and use of the City of Bryant parks, facilities, and rights of way in connection with the permitted event the organization:

(Permittee/Sponsoring Organization)

hereby agrees to reimburse the City of Bryant for any and all costs incurred in repairing damage to City Property proximately caused by the actions of the permittee/sponsoring organization, its officers, employees, or agents, or any persons who are, under the permittee/sponsoring organization's control insofar as permitted by law occurring in connection with a special event known as:

(Event Name)

scheduled on:

(Event Date(s))

The permittee/sponsoring organization further agrees to hold harmless, indemnify and defend the City of Bryant, its officials, members, agents, and employees against any claims, costs, damages, demands, liability, and notices, of any kind or nature whatsoever arising or resulting from any damage or injury proximately caused by actions of the permittee/sponsoring organization, its officers, employees, or agents, or any person under its control in connection with the permitted event, regardless of whether the city is actively negligent or passively negligent.

I am authorized to act as an officer or agent of the permittee/sponsoring organization with full authority to execute this agreement in its name and on its behalf for the purposes herein stated.

Authorized Officer of Sponsoring Organization

Date

Permit Applicant

Date

Witness

Date

SAMPLE PLANS FOR PERMIT RELATED ALCOHOL ISSUES

PAGE #5

THESE SAMPLE PLANS ARE A GUIDE TO ASSIST YOU IN DEVELOPING
A STRATEGY TO PREVENT ALCOHOL MISUSE AT YOUR EVENT.

PLEASE MAKE SURE YOUR PLAN IS SIGNED BY AN AUTHORIZED OFFICER OF THE SPONSORING ORGANIZATION.

SAMPLE PLANS FOR KEEPING MINORS FROM OBTAINING ALCOHOL

- 1 (Event Sponsor) requires all patrons age twenty-one (21) and over to wear identification wristbands. Our gate personnel check all identification cards at the park entrance and place a wristband on all who are age twenty-one (21) and over who plan to purchase and consume alcohol.

Beverage sales personnel will have printed copies of this alcoholic beverage plan available at each alcoholic beverage point of sale. Additionally, each person dispensing alcoholic beverages will be given a briefing regarding the prohibition against the sale of alcoholic beverages to minors or to anyone not wearing an armband.

Alcohol will be served in cups of a single color, specifically designated for alcohol to aid police officers and security staff in identifying prohibited activity.

(# of Staff) event volunteers have been assigned the task of walking the event area in search of any minors or adults not in compliance with the alcohol regulations. All violators will be reported to the police.

- 2 (Event Sponsor) requires all patrons age twenty-one (21) and over to be stamped with a unique hand stamp that cannot be transferred to other patrons without easy detection. Our gate personnel will check all identification cards at the park entrance and place the unique indelible ink hand stamp on all who are age twenty-one (21) and over who plan to purchase and consume alcohol. Beverage sales personnel will be instructed to closely examine the hand stamp prior to selling alcoholic beverages to assure under aged persons do not display a reverse transfer of the hand stamp.

Beverage sales personnel will have printed copies of this alcoholic beverage plan available at each alcoholic beverage point of sale. Additionally, each person dispensing alcoholic beverages will be given a briefing regarding the prohibition against the sale of alcoholic beverages to minors or to anyone not wearing the proper hand stamp.

Alcohol will be served in cups of a single color, specifically designated for alcohol to aid police officers and security staff in identifying prohibited activity.

(# of Staff) event volunteers have been assigned the task of walking the event area in search of any minors or adults not in compliance with the alcohol regulations. All violators will be reported to the police.

SAMPLE PLANS FOR KEEPING SPECTATORS FROM BRINGING THEIR OWN ALCOHOLIC BEVERAGES

- 1 (Event Sponsor) will have signs posted at the entrance to the event and in designated parking areas, prohibiting any outside alcohol or weapons from being carried onto the event premises in ice chests, large bags or other containers. Volunteers posted at the entrance. Staff and/or Volunteers posted at the entrance have been instructed not to allow any ice chests, large bags, or otherwise from entering the event grounds without inspection to assure no alcoholic beverages and/or weapons are being transported into the event.

Alcohol will be served in cups of a single color, specifically designated for alcohol to aid police officers and security staff in identifying prohibited activity.

Persons found in violation of this prohibition inside the event premises will be banned from the event by event staff and are subject to arrest. Additionally, persons who refuse to allow event staff to search containers/bags/et cetera will not be allowed inside the event area.

- 2 (Event Sponsor) makes the general public aware of its policy/position regarding the prohibition of outside alcohol in the event area in all pre-event promotional and advertising efforts. Additionally, the group places signs noting “**NO OUTSIDE ALCOHOL OR PERSONAL ICE CHESTS ARE ALLOWED INSIDE THE EVENT AREA**” at all parking areas and entrances to the event area.

Alcohol will be served in cups of a single color, specifically designated for alcohol to aid police officers and security staff in identifying prohibited activity.

Persons found in violation of this prohibition inside the event premises will be banned from the event by event staff and are subject to arrest. Additionally, persons who refuse to allow event staff to search containers/bags/et cetera will not be allowed inside the event area.

POLICE EVENT CHECKLIST

This Bryant Parks Department Special Event Application is to be submitted to the Bryant Police Department at least 45 days prior to the event. Applications must be submitted *in person or by U.S. Mail*. No facsimiles!

SUCCESSFUL APPLICATIONS WILL INCLUDE THE FOLLOWING INFORMATION WHEN APPLICABLE:

<input type="checkbox"/>	Fully completed Special Event Application submitted at least 45 days prior to proposed event. <small>PLEASE CALL (501 943-0444) IF YOU NEED ASSISTANCE COMPLETING THE SPECIAL EVENT FORM!</small>
<input type="checkbox"/>	Detailed Diagram of event area.
<input type="checkbox"/>	Signed, witnessed and dated Indemnification Agreement.
<input type="checkbox"/>	Copy of APPLICATION for Arkansas Alcoholic Beverage Permit. <i>An actual copy of the alcoholic beverage PERMIT you receive from the state must be presented the week preceding the event.</i>
<input type="checkbox"/>	Signed and dated plan to prevent alcohol sales to minors during event.
<input type="checkbox"/>	Signed and dated plan to prevent patrons from bringing alcoholic beverages into event. <i>The two alcohol plans may be combined on one page if desired.</i>
<input type="checkbox"/>	Copy of insurance (in required amounts) showing the city as additional insured.
<input type="checkbox"/>	Copy of City Park Use Agreement (required if event is held in a city park).
<input type="checkbox"/>	Other supporting documentation.
<input type="checkbox"/>	Scheduled meeting with Parks Director & Events Coordinator to discuss event security/plans.

Other Helpful Links/Information

Arkansas Department of Finance and Administration/Alcohol Beverage Control Division
100 Main Street Suite #503, Little Rock, Arkansas 72201 // (501)682-1105 Fax: 501-682-2221
<http://www.state.ar.us/dfa/abcadministration/index.html>

Arkansas Festival Association <http://www.arkansasfestivalassociation.org/>

City of Bryant, Arkansas <http://www.cityofbryant.com>

Parks Director (501) 416-6396 or Event Coordinator: (501) 747-3829

City Ordinance available at <http://www.municode.com> Select "Online Library" then click on the map of "Arkansas" and select Bryant from the list.

International Portable Sanitation Association guidelines for estimating the number of sanitation units that may be necessary for a special event.										
Numbers of Hours for Event										
	1	2	3	4	5	6	7	8	9	10
Crowd Size	Number of Portable Restrooms									
1-500	4	4	4	6	6	6	8	8	8	8
501-1000	4	6	6	6	6	8	8	8	8	12
1001-2000	8	8	8	8	8	12	12	12	12	16

To meet ADA, 5% of facilities but not less than one toilet must be wheelchair accessible.

RESOLUTION NO. 2015-_____

RESOLUTION ADOPTING THE 2015 EDITION OF THE STANDARD SPECIFICATIONS FOR DESIGN AND CONSTRUCTION OF WATER LINES AND SEWER LINES FOR THE CITY OF BRYANT

WHEREAS, the City of Bryant owns and operates a water distribution system and a wastewater collection and treatment system; and

WHEREAS, the City has existing minimum standards for the design and construction of water lines and sewer lines; and

WHEREAS, it has been determined by the City of Bryant Department of Public Works that the existing minimum standards for design and construction of water and sewer lines do not provide adequate protections to the City and its water and wastewater system; and

WHEREAS, it is necessary from time to time to update and improve standards in order to protect the integrity of the systems and minimize future expenses resulting from substandard design and construction; and

WHEREAS, the City of Bryant Department of Public Works has developed its 2015 Edition of the Standard Specifications for Design and Construction of Water Lines and Sewer Lines; and

WHEREAS, 2015 Edition of the Standard Specifications for Design and Construction of Water Lines and Sewer Lines is awaiting approval by the Arkansas Department of Health; and

WHEREAS, The City Council of the City of Bryant finds that adoption of the 2015 Edition of the Standard Specifications for Design and Construction of Water Lines and Sewer Lines, as approved by the Arkansas Department of Health is necessary and proper to the continued management, growth and protection of the City of Bryant water and wastewater system.

NOW THEREFORE, BE IT RESOLVED BY THE CITY COUNCIL OF THE CITY OF BRYANT, ARKANSAS THAT:

Section 1. The City Council of the City of Bryant hereby adopts the 2015 Edition of the Standard Specifications for Design and Construction of Water Lines and Sewer Lines when and as approved by the Arkansas Department of Health.

Section 2. Any resolution, resolution section, policy or directive in conflict with this Resolution is repealed or amended to reflect and achieve the purposes stated herein.

PASSED AND APPROVED this _____ day of _____, 2015

{Signatures on the following page}

APPROVED:

Jill Dabbs, Mayor

Approved as to Form

ATTEST:

Sue Ashcraft, City Clerk

Richard Chris Maddison, Staff Attorney

**STANDARD SPECIFICATIONS FOR
DESIGN AND CONSTRUCTION OF
WATER LINES AND SEWER LINES**



**CITY OF
BRYANT
ARKANSAS**

City of Bryant, Arkansas

1019 S.W. 2nd Street

Bryant, AR 72022



2015 EDITION

City of Bryant - Water System Material Specifications - Short Form

Water System Material	City of Bryant Specification
PVC Pipe - Less than 4"	SDR-13.5
PVC Pipe - 4" through 8"	SDR-14 or C900
Ductile Iron Pipe - 10" and larger	250 PSI Pressure Class
Joint Restraint	Megalug Series 1100 by EBAA
Tracer Wire Splice Caps	Carsonite Model LCTSI508
Tracer Wire Splice Poles	Carsonite Model CTP307201
Marking Tape	Terra Tape "Extra Stretch" Rhino Marking and Protection Systems Harris Industries, Inc.
Water Line Marker Signs	Carsonite International
Gate Valves	Mueller Series 2360 American Flow Control Series 2500 Clow Corporation
Valve Boxes	East Jordan Iron Works 8550 Series Mueller Tyler Union 6850 Series
Butterfly Valves	Pratt HP250II Dezurik BAW
Tapping Sleeves	Smith-Blair 662 Style FAST by Ford Meter Box Company
Fire Hydrants	M&H Valve Company - Style 129 Mueller Super Centurion 250 American Flow Control 5-1/4" Waterous Pacer WB67-250 Clow
Blow-Off Hydrants	Mainguard No. 77
Air Relief Valves (1" & 2")	A.R.I. Model D-040
Air Relief Valves (3" to 10")	A.R.I. Model D-060-C HF
Combination Air Valve (2" & larger)	A.R.I. D-050
Meter Box	DFW Plastics Polymer Body
Meter Box Lid	DFW Plastics Polymer Lid - Bryant
Meter Setter	A.Y. McDonald NL 726-207WX2D 33
Tapping Saddle	A.Y. McDonald Hinged Saddle 3891 Romac 101 NS
Corp Stop	A.Y. McDonald NL Plug Style 74701-22 Ford FB1000-4-Q-NL Mueller B25008N
Service Tubing	SDR 9 HDPE Tubing

City of Bryant - Sewer System Material Specifications - Short Form

Sewer System Material	City of Bryant Specification
PVC Service Line (4" and larger)	SDR26 or SCH 40
Valve Box for Cleanouts	Model 70 East Jordan Iron Works
Cleanouts	Two-Way Memphis Code, SCH 40 PVC
PVC Force Main (4" or less)	SDR 21
PVC Force Main (4" to 12")	SDR 21 or AWWA C900 (DR 25 min.)
PVC Force Main (Greater than 12")	AWWA C905 (DR 25 min.)
Ductile Iron Pipe for Force Mains	Pressure Class 250 psi min. AWWA C1511A21.57
PVC Gravity Sewer Pipe (Solid Wall - 15" or less)	SDR 26 via ASTM D 3034
PVC Gravity Sewer Pipe (Solid Wall - Greater than 15")	ASTM F 679 - PS115
Ductile Iron Pipe for Gravity Sewer	AWWA C151/A21.51
Interior Lining for Ductile Iron Pipe and Fittings at Pump Station Site	Protecto 401 Ceramic Epoxy
Interior Lining for Ductile Iron Pipe and Fittings Not at a Pump Station	Cement Mortar Lining - AWWA C104
Centrifugally Cast Fiberglass Gravity Sewer Pipe	ASTM 3262 (PS 46 psi min.)
Joint Restraints (MJ)	D.I. Pipe 3"-16" Series 1100 by EBBA Iron, Inc.
	D.I. Pipe 18"-48" Series 1100 by EBBA Iron, Inc.
	PVC Pipe 3"-36" Series 2200 PV by EBBA Iron, Inc.
	PVC Pipe 42"-48" Series 2200 by EBBA Iron, Inc.
Bell Restraints - PVC (4" to 12") AWWA C900	EBBA Iron Series 1900 Restraint Harness
Bell Restraints - PVC (2"-12") SDR 21	EBBA Iron Series 6500 Restraint Harness
Bell Restraints - PVC (14"-36") AWWA C905	EBBA Iron Series 2800 Restraint Harness
Bell Restraints - Ductile Iron (4" to 48")	EBBA Iron Series 1700 Restraint Harness
Gate Valves	Mueller Series 2360
	American Flow Control Series 2500
	American AVK Company Series 25 or Series 45
Full port plug valves	AWWA C517
	Val-Matic
	Dezurik PEC
Sewage Air & Vacuum Release Valve	A.R.I. #D-025 NPT
Reinforced Flexible Rubber Couplings	Fernco with S.S. Sheer Ring
Interior Corrosion Protection for Manholes within 100' of 15" Sewer, on 15" & Larger Sewer Lines, and at Pump Station Site. Sewage Pump Station Wetwell	Quadex Structure Guard by Quadex, Inc. (80-100 mils)
	Strong Seal Epoxy by the Strong Company (80-100 mils)
	Raven Ultra High-Build Epoxy Coating, Raven 405 (80-100 mils)
All Other Manholes (Interior Protection)	Carboline Bitumastic - 300 M
External Joint Sealant for Manhole and Sewage Pump Stations	Bidco Butyl Wrap by NPC - 6" wide min.
	Infi-Shield® Gator Wrap by Sealing Systems, Inc. - 6" wide min.
Standard Manhole Ring & Cover	Model 1266 Deeter Foundary
	Model V1348-1 East Jordan Iron Works
Manhole Steps	None Required
Manhole Inserts (Rain Stoppers)	HDPE via ASTM D1248
	Stainless Steel Inflow Systems, Inc., Largo, Florida
Manhole Riser Rings Waterproofing	Trowelable EZ-STIK #3 by Press-Seal Gasket Corporation
Sewage Pump Station	Flygt Pump Equipment
Individual Grinder Pump Station	Environmental One Corporation
Tracer Wire	12 Gage Solid Coated Copper - Green in Color
Marking Tape	Terra Tape "Extra Stretch" - Green in Color
	Rhino Marking and Protection Systems - Green in Color
	Harris Industries, Inc. - Green in Color
Sewer Line Marker Signs	Carsonite International
	Rhino Marking and Protection Systems

City of Bryant, Arkansas
Water and Sewer Specifications and Standard Details

TABLE OF CONTENTS

WATER AND SEWER SPECIFICATIONS

<u>Section</u>	<u>Title</u>	<u>Pages</u>
1000	General Requirements and Procedures	2
1100	General Design Standards – Water	14
1200	General Design Standards – Sewer	13
2000	Trench Safety	1
2100	Erosion and Sediment Control	8
2200	Site Preparation	3
2300	Excavation, Backfilling, and Compacting	7
3000	Sewer Pipe, Fittings, and Materials	9
3100	Installation of Sewer Pipe, Fittings, and Materials	9
3200	Installation of Sewer Service Lines	6
3300	Manholes	10
3400	Steel Encasement Pipe	4
3500	Sewage Pump Stations	10
3501	Individual Sewage Grinder Pump Stations	12
3600	Cast-In-Place Concrete	3
4000	Water Pipe, Fittings, and Materials	14
4100	Installation of Water Pipe, Fittings, and Materials	13
4200	Water Line Pressure Reduction Procedures	1
5000	Sewer Line Cleaning	3
5100	Sewer Line Television Inspection	3
5200	Inspection and Testing of Sewer Lines, Manholes, and Service Lines	7
5300	Inspection and Testing of Water Lines and Service Lines	4
6000	Asphalt Pavement Repair	4
6001	Concrete Pavement Repair	5

City of Bryant, Arkansas
Water and Sewer Specifications and Standard Details

TABLE OF CONTENTS

WATER AND SEWER SPECIFICATIONS CONTINUED

6002	Gravel Surfacing Repair	2
6100	Lawn and Grass Restoration	8
6700	Fencing	5

WATER DETAILS

Section Title

W1	Water Main Trench (Non-Paved Area)
W2	Water Main Trench (Under Pavement)
W3	Water Main Installation Prior to Roadway Construction
W4	Gate Valve
W5	3-Way Gate Valves
W6	Butterfly Valve
W7	Valve Stem Extension
W8	Fire Hydrant and Valve
W9	Fire Hydrant Placement
W10	Meter Settings
W11	Meter Service Line Under Pavement
W12	1-1/2 inch and 2 inch Water Meter
W13	Tapping Sleeve and Valve
W14	Polyethylene Protection Material
W15	Steel Encasement
W16	Thrust Blocking
W17	Vertical Tie-Down Blocking
W18	Anchor Collar
W19	Blow-off Assembly

City of Bryant, Arkansas
Water and Sewer Specifications and Standard Details

TABLE OF CONTENTS

WATER DETAILS CONTINUED

W20	Swing Connection
W21	Valve Cut-In
W22	Valve Marker
W23	1 inch Air Release
W24	2 inch Air Release
W25	Vertical Offset
W26	Restrained Coupling
W27	Cut and Cap
W28	Abandon Water Valve
W29	Chain Link Fence Detail
W30	Wood Fence Detail

SEWER DETAILS

<u>Section</u>	<u>Title</u>
S1	Sewer Trench (Non-Paved Area)
S2	Sewer Trench (Under Pavement)
S3	Sewer Main Installation Prior to Roadway Construction
S4	Cast In Place Manhole
S5	Precast Manhole
S6	Manhole Frame and Cover
S7	Hinged Manhole Frame and Cover
S8	36-Inch Manhole Frame and Cover
S9	Manhole Joint Wrap
S10	Drop Manhole
S11	Manhole Coring

City of Bryant, Arkansas
Water and Sewer Specifications and Standard Details

TABLE OF CONTENTS

S12	Manhole Adjust to Grade
<u>SEWER DETAILS CONTINUED</u>	
S13	Manhole Abandonment
S14	Sewer Line Disconnect and Seal
S15	Sewer Service Lateral
S16	Sewer Service Cleanout
S17	Sewer Service Saddle
S18	Reinforced Flexible Coupling
S19	Connect to Existing Sewer Service
S20	Polyethylene Protection Material
S21	Steel Encasement
S22	Steel Encasement – Aerial Crossing
S23	Bank Stabilization
S24	Sewer Marker
S25	Force Main Thrust Blocking
S26	Air Release Valve
S27	Concrete Encasement
S28	Emergency Pump Connection
S29	Gate Valve
S30	3–Way Gate Valves
S31	Concrete Pier
S32	Gravel Drive For Sewage Pump Station
S33	Tracer Wire Test Station

SECTION 1000

GENERAL REQUIREMENTS AND PROCEDURES

PART 1 - GENERAL

1.01 WORK INCLUDED

- A. These Specifications for water and sewer design and construction are provided to outline the City of Bryant's procedures and minimum criteria for the design and construction of water and sewer lines within the City of Bryant.
- B. The Public Works Director's office is responsible for the issuance of construction permits for the installation of all water and sewer facilities constructed in the City of Bryant. Water and sewer facilities shall be designed and constructed in accordance with these Specifications.
- C. A preconstruction meeting shall be held before initializing work. Two (2) full sets of construction drawings shall be provided to the Water and Sewer Department before work begins.
- D. These Specifications set forth the minimum criteria for the design and all work in connection with the construction of water and sewer lines within the jurisdiction of the City of Bryant including the entire system and its appurtenances from the water distribution system to the point of connection at the water meter and the entire sewerage system and its appurtenances from the point of connection with the building plumbing to the discharge terminus of the treatment plants' outfalls. The City Municipal Code and all Ordinances of the City of Bryant shall be considered a part of these Standards; and all drawings, profiles, cut sheets, easement documents, and specifications shall conform to the standards and requirements herein established. Addenda and/or revisions to these Specifications by the City of Bryant may be issued periodically and will be distributed and made available to the public and contractors at the offices of the Public Works Director. Users of this text are urged to review the latest revisions or editions to these Specifications to apprise themselves of any changes/revisions.
- E. Where the requirements of another jurisdictional authority having influence on work outside the purview of the City of Bryant are greater than that provided by these Specifications, the work shall conform to the greater requirement of that respective jurisdictional authority.
- F. The Owners of the project shall be responsible for procuring all necessary permits and licenses, paying all charges and fees, acquiring and recording all easements and giving all notices necessary and incidental to the work.
- G. All construction projects shall conform to these Specifications for acceptance by the City of Bryant. All construction drawings and specifications must be approved by the City of Bryant before construction begins. Full time construction observation services shall be provided by the Engineer of record. Final acceptance testing will be coordinated with the City. The City of Bryant shall be given a minimum of forty-eight (48) hours notice prior to the commencement of construction projects for observation purposes.
- H. These Specifications are provided with the intent of reducing project document assembly and agency review, and to provide for the highest quality construction methods and materials.
- I. These Specifications are written in imperative and abbreviated form. The imperative language is directed at the Contractor, unless specifically noted otherwise. Incomplete sentences shall be completed by inserting "shall", "the Contractor shall", "shall be", and similar mandatory phrases by inference in the same manner as they are applied to notes on the Drawings. The words "shall be:" shall be supplied by inference where a colon (:) is used within sentences or phrases. Except as

worded to the contrary, all indicated requirements shall be performed whether stated imperatively or otherwise.

- J. Questions and comments concerning these Specifications should be directed to the Public Works Director's Office, 1019 S.W. 2nd Street, Bryant, Arkansas 72022, (501) 943-0447.

1.02 DEFINITIONS

- A. City – The City of Bryant.
- B. Engineer – The Engineer of record for the City.
- C. Owner – Any Individual, partnership, firm, corporation or other entity who, as property owner, is initiating the work.
- D. Provide – Furnish and install, complete in place, operating, tested and approved.
- E. Products – The materials, systems, and equipment provided by the Contractor.

1.03 SUBMITTALS

- A. Initial submittal for review shall be in PDF format.
- B. Five (5) hard copies and one (1) PDF copy of submittal documents must be sent to the Engineer.
- C. The Engineer of Record shall submit permitted submittal documents to the City of Bryant before releasing them to the contractor. Legible scanned copies will be permitted for review. The City of Bryant reserves the right to make corrections as necessary to ensure compliance with these specifications.
- D. Construction procedures other than those outlined in these specifications shall be submitted for approval of the City of Bryant.
- E. Complete specifications covering any unusual or special construction procedures shall be submitted for approval and approval must be received prior to beginning any construction operations.
- F. A minimum review time of two (2) weeks shall be required on all submittals.

1.04 MAINTENANCE BOND

- A. Once the City accepts the project for ownership, the Owner shall be responsible for the provision to the City of a two (2) year maintenance bond for 50 percent of the construction cost of water lines and sewer lines, which shall cover defects in materials and workmanship. A walk-through shall be performed at the end of the two year period and all deficiencies corrected prior to release of the bond. City maintenance shall begin after expiration of the two (2) year Maintenance Bond.
- B. If installation of water lines and sewer lines is in conjunction with a development project that includes other public works improvements such as streets, drainage, etc., then the maintenance bond shall be supplied for a period of two (2) years at the percentage of construction as outlined in the current City Ordinance.

END OF SECTION 1000

SECTION 1100**GENERAL DESIGN STANDARDS - WATER****PART 1 – GENERAL**

1.01 GENERAL

- A. Construction permits shall be obtained from the Code Enforcement/Permits Office for the installation of all water facilities connecting to Bryant Water System in accordance with the City Ordinance. Water lines shall be designed and installed in accordance with the Standard Specifications for Design and Construction of Water Lines and Sewer Lines.

1.02 PROTECTION OF EXISTING WATER SYSTEM

- A. Only authorized personnel from the City of Bryant Water & Sewer Department are permitted to operate valves on the existing water system. Under no circumstance shall the Contractor operate any valve on the existing water system.

1.03 WATER LINE MATERIALS

- A. Materials for water line mains up to and including 8-inch shall be PVC.
- B. Ductile iron pipe shall be used for all fire lines, fire hydrant connections, and all pipe greater than 8-inches in diameter.
- C. All buried iron pipe, valves, and fittings shall be poly wrapped in accordance with these specifications.

1.04 REQUIREMENTS TO EXTEND WATER SERVICE

- A. All new development of any kind shall be required to extend water services to that development at the owner's expense. Water lines shall be extended to each property to be served by City of Bryant water. This includes all new developments, infill projects, and lot splits. Water service shall include providing adequate domestic water flows as well as fire protection with hydrants spaced in accordance with the local and state fire codes.
- B. Water service lines shall extend perpendicular to the water main and extended to the property being served where an appropriately sized water meter will be installed.
- C. On subdivision or large scale development water systems, water lines shall be extended through all the development to the property line so that future development(s) can tie on without disrupting the service to or property of any existing customers or owners. Dead end lines shall be avoided whenever possible.
- D. All water lines with dead ends shall be installed with an upstream valve, one full joint of ductile iron pipe with a MJ restraining gland, concrete anchor collar, a MJ cap with restraint, and a blow off assembly. The seat of the MJ restraining gland on the ductile iron pipe shall face the valve.
- E. Developments shall tie to the existing water system at a minimum of two locations to maintain water quality and maintain water service in the event of a water line break in the immediately vicinity. An inline valve shall be installed on the existing water line between the two points of connection if one is not currently installed. Water line extensions shall be required off the development to loop with the existing water distribution system. Construction of such extensions shall be at the expense of the developer.

- F. At other locations easements may be required to facilitate future extension of lines to adjacent properties.
- G. The requirements to extend water service and provide lines adequate for both domestic and fire demands shall apply to all subdivisions regardless of whether they are inside the City Limits or not.

1.05 MINIMUM SIZE OF WATER LINES

- A. The minimum sized line that may be installed in the water system is six (6) inch. This is required even if the line is being extended from an existing line that is smaller than six (6) inches. Two (2) inch lines may be approved for cul-de-sacs provided the line could not be reasonably extended in the future to provide service to adjacent property and where a larger line is not needed to provide either fire protection or adequate domestic flows. Refer to Paragraph 1.21 – Fire Hydrant Spacing and Placement.
- B. The minimum line size requirement for the provision of fire protection shall be a looped 8-inch line or, in the event of a dead end line, an 8-inch. This minimum requirement shall apply regardless of the theoretical flow capacities existing in the system. Water lines larger than 8-inch may be required if they are needed to provide domestic and fire flow demands for a development.
- C. The current Bryant Water System Master Plan must be referenced for minimum water line sizes. Refer to Part 1.09 of this Section.

1.06 WATER SERVICE LINES

- A. Water service connections shall be made on 12-inch and smaller water lines.
- B. Service lines serving single meter sets and double meter sets shall be 1-inch HDPE tubing in accordance with these specifications.
- C. Service lines serving 1-1/2 inch and 2-inch meter sets shall be 2-inch HDPE tubing in accordance with these specifications.
- D. Water services lines installed across city streets shall be encased back of curb to back of curb, or state highway right-of-way to right-of-way. 1-inch lines shall be encased in 1-1/2 inch HDPE SDR9 tubing. 2-inch lines shall be encased in 3-inch HDPE SDR9 tubing.
- E. Service lines serving 3-inch and large meter sets shall be PVC in accordance with these specifications.

1.07 WATER METER SIZE

- A. Water meters serving flows up to 10 gpm continuous (15 gpm intermittent) shall be 5/8-inch water meter.
- B. Facilities that use flush valve style (tankless) toilets shall use a minimum 1-inch water meter.
- C. Water meters serving flows up to 25 gpm continuous (40 gpm intermittent) shall be 1-inch water meter.
- D. Water meters serving flows greater than 25 gpm continuous shall be approved by the City of Bryant during the plan review process.

1. For reference only, meter flow ranges may be as follows:
 - a. 1-1/2 inch meter up to 65 gpm continuous (100 gpm intermittent)
 - b. 2-inch meter up to 150 gpm continuous (200 gpm intermittent)

Water meters greater than 2-inch must be reviewed and approved by the Bryant Public Works Department on a case-by-case basis.

1.08 BACKFLOW PREVENTION

- A. The City of Bryant water distribution system shall be protected from the possibility of backflow by the use of a reduced-pressure principal backflow prevention assembly (RPZ), a double check valve assembly (DC), or an air gap in accordance with the Arkansas State Plumbing Code (ASPC), latest edition.
- B. The City of Bryant Water & Sewer Department shall review and sign off on all proposed backflow prevention installations.
- C. The following is a partial list of facilities which ordinarily will require a reduced-pressure principal backflow prevention assembly (RP) or an air gap in accordance with the ASPC, latest edition. Requirements are based upon the degree of hazard afforded the public potable water system.
 1. Automatic car washes.
 2. Auxiliary water systems (interconnected with the public water system).
 3. Exterminators and veterinary clinics.
 4. Facilities with boilers, condenser water or chilled water systems.
 5. Fire systems containing chemical additives.
 6. Hospitals, medical clinics, dental clinics, health clinics, sanitariums, morgues, mortuaries, autopsy facilities, nursing and convalescent homes.
 7. Irrigation systems and lawn sprinkler systems.
 8. Laboratories (industrial, commercial, photography, medical and school).
 9. Commercial laundries.
 10. Radiator and battery shops.
 11. Restricted, classified or other facilities closed to inspection.
 12. Sand, gravel and concrete plants.
 13. Wastewater treatment plants, pump stations, and storm water pumping facilities.
 14. Commercial swimming pools.
 15. Commercial farms using pesticides and herbicides.

16. Establishments holding livestock for sale or slaughter including cattle, horses, hogs, poultry, emus, ostriches, llamas, rabbits, etc.
 17. Others (with suspected high hazards).
- D. The following is a partial list of facilities which ordinarily will require a minimum of DC or an air gap in accordance with the ASPC, latest edition:
1. Tall buildings (over four stories) or any buildings with water booster pumps.
 2. Beauty parlors and barber shops.
 3. Hotels and motels.
 4. Restaurants, cafeterias, fast-food marts and other food handling facilities.
 5. Fire sprinkler systems (without chemicals).
 6. Others (with suspected medium hazards).

1.09 WATER SYSTEM MASTER PLAN

- A. The City's latest Water System Master Plan shall be the primary basis for decisions made in regard to required line sizes, water line locations, location of water pump stations, water tank sizes and location, and any other matter relating to the water distribution system.
- B. The Public Works Director shall have the discretion to alter these requirements.

1.10 CITY PARTICIPATION IN WATER LINE COSTS

- A. In cases where the City desires to have a larger sized water line in place than is required under Paragraph 1.03 of these Specifications, the City may enter into an agreement with the developer to provide for the construction of the larger sized line.
- B. In that event, the City shall be responsible for the difference in material costs only between the size line required for the developer and the size line desired by the City. The City shall not be responsible for any engineering cost associated with the up-sizing unless the larger size line is more than 12-inches in diameter. The City shall not participate in the cost of an 8-inch or smaller line, except that the City may consider participating in the cost of smaller lines when a small number of customers are involved in a non-development situation.
- C. The cost involved in up-sizing shall be determined by the developer's engineer by the taking of bids, and shall be approved by the Public Works Director and by the City Council.

1.11 EASEMENTS

- A. For water lines that are up to 10 feet deep, easements shall be at least 15 feet in width with the water line in the center of the easement. For water lines that are greater than 10 feet deep, easements shall be 1 foot per foot of depth to the bottom of the pipe on each side of the water line. The easement may be designated specifically for water line purposes or it may be a general utility easement.
- B. New developments that contain existing water lines must modify the existing easements as necessary to meet the above requirements for widths in relation to pipe location and size, including increasing the size of the easement if proposed fill will cause the depth of bury to exceed ten feet.

- C. Easements of a lesser width will be considered when adjacent to another easement or under other special circumstances.

1.12 PERMITS

- A. All permits required to accomplish the work shall be the responsibility of the owner. Such permits may include but are not limited to permits for work within Highway Department right of way, railroad crossing permits, "Notice of Intent" for Erosion Control (Arkansas Department of Environmental Quality) Drainage Permit, Grading Permit. Work shall not be started without the appropriate permit(s) in place.

1.13 APPROVAL OF WATER EXTENSION PLANS

- A. Detailed plans and specifications shall be required for all extensions and shall be prepared by a professional engineer registered to do business in the State of Arkansas.
- B. The plans and specifications shall be first approved by the Public Works Director and then shall be forwarded to the Arkansas Department of Health by the Engineer of Record for their approval. In no case shall any water line construction be allowed before the City has written approval from the Arkansas Department of Health.
- C. Private lines constructed for fire prevention purposes which have no metering device or backflow prevention device at the point of tie-in to the City main shall be treated as a public line and be subject to these specifications as far as engineering, construction techniques, materials, testing, and inspections are concerned. After a final inspection and acceptance of the work, the line shall be owned and maintained by the owner of the property it serves.
- D. No construction of any kind may begin without an erosion control plan on file with the City. The erosion control measures (see stormwater manual) must be in place in the field prior to construction. For projects that require a permit, it is the responsibility of the contractor to have on file with the Arkansas Department of Environmental Quality a "Notice of Intent".
- E. Written notice of the intent to begin construction must be given to the City no less than three (3) days nor more than ten (10) days prior to the construction start date. A pre-construction conference involving the Engineer of Record, Contractor, and the City is required prior to beginning construction.

1.14 LOCATION OF WATER LINES

- A. Water lines shall be placed on public streets either in the right of way or in an easement adjacent to the street right of way except that lines can go between lots when there is no other reasonable way to access a line or provide for future service. In no case shall lines intended for individual services be placed in the rear of lots or along back property lines.
- B. Water lines shall be located a minimum of 36-inches from any other parallel utilities or structures.

1.15 LOCATION OF WATER METERS

- A. Water meters shall be located in non-paved areas and readily accessible to the City without going through fences or gates.
- B. Water meters shall be free of obstructions for a minimum of a 3-foot radius from the center of the water meter box.
- C. Water meters shall be located on the Owner's side of the property line (edge of easement or right-of-way).

- D. Double meter sets shall be located on the common property line between the two properties being served.

1.16 VALVE MARKERS

- A. In all rural settings except those in cleaned yards, when valve boxes, bends, air release valves, blow-offs, meter boxes and other similar hardware are installed in an easement location, water system marker signs shall be installed so that the items may be easily found.

1.17 WATER LINE DEPTH

- A. Minimum depth to the top of pipe for all water main lines shall be 3.0 feet.
- B. Minimum depth to the top of pipe for water lines 18-inches and greater shall be 4.0 feet.
- C. Maximum water line cover shall be 5.0 feet under normal conditions. Cover greater than 5.0 feet shall be allowed for short distances where required by field conditions and approved by the City. Water line depth shall be shown on the as-built drawings.
- D. Minimum depth of all water service lines from the main to the water meter shall be 30-inches.

1.18 WATER PRESSURE

- A. The water distribution system shall be designed to maintain a minimum working water pressure of 45 psi at the water meter.
- B. Design of new construction that results in less than 45 psi working pressure at the water meter shall be approved by the Public Works Director on a case by case basis.
- C. Under no circumstances shall the working pressure of the water distribution system be below 20 psi.

1.19 VELOCITIES

- A. Velocities in the water distribution system shall be sized such that velocities will be no greater than five (5) feet per second during normal operation conditions.
- B. Velocities during fire flow conditions shall not exceed ten (10) feet per second.

1.20 VALVES

- A. Valves for 2-inch through 12-inch water distribution shall be resilient seat gate valves.
- B. Valves 14-inch and larger shall be butterfly valves.
- C. Valve spacing in the water distribution system shall not exceed 500 feet in commercial areas, or more than one block or 800 feet in all other areas.
- D. Valves at tees shall be such that a valve is located immediately adjacent to each leg of the tee.
- E. Valves shall be located on each side of a major stream crossing along with leak detection.

1.21 FIRE FLOW DESIGN

- A. Fire flow design for single family dwellings and duplexes shall be 1,500 gpm for a duration of two (2) hours.
- B. Fire flow design for apartment complexes, commercial structures, and industrial structures shall be as outlined the International Fire Code, latest edition.

1.22 FIRE HYDRANT SPACING AND PLACEMENT

- A. Fire hydrants for single family dwellings and duplexes shall be installed so that (1) the distance between two consecutive fire hydrants does not exceed 500 feet, and (2) no lot is more than 250 feet from a fire hydrant.
- B. Fire hydrants in areas for apartment complexes, commercial structures, and industrial structures shall be installed so that the distance between two consecutive fire hydrants does not exceed 400 feet. The Fire Chief shall have the authority to require additional fire hydrants upon a determination that such additional fire hydrants are necessary to provide adequate fire protection as outlined in the International Fire Code, latest edition.
- C. Fire hydrants shall be free of obstructions for a minimum of a 3-foot radius from the center of the fire hydrant. Fire hydrants shall be placed outside of all fences.

1.23 FIRE LINES

- A. Fire lines, backflow prevention, and FDC shall be installed and inspected the same as water lines.
- B. Fire lines shall be constructed of ductile iron pipe and shall be poly wrapped.
- C. All valves for fire lines shall have the word "FIRE" on the valve box lid, this includes the valve on the water main. Post indicator valves shall be installed on all fire lines to demarcate ownership. Post indicator valves shall match the valve manufacturer.

1.24 AIR RELEASE VALVES

- A. Air release valves shall be required on uphill, dead-end lines or on other specific applications to protect the water distribution system at the discretion of the Public Works Director.

1.25 STEEL ENCASEMENTS

- A. Water lines under culverts, creeks, concrete channels, retaining walls, or other difficult and/or dangerous to maintain areas shall be encased in a smooth steel encasement pipe. The steel encasement shall extend 5 feet either side of the area.
- B. Water lines through steel encasement shall be installed with three spacers per joint such that the spacers are equally spaced along the length of the pipe.
- C. Self-restraining gaskets (DIP only) or bell restraints shall be used for all joints inside the encasement pipe and for the first joint in each direction outside the encasement pipe.
- D. End seals shall be used on all encasement pipes.
- E. Ductile iron water pipe shall be used in situations where fittings other than a "tee" are required on either side of the steel encasement to change direction or overcome varying field conditions. Additional joint restraints and the use of anchor collars shall be required as directed by the City.

1.26 PLANNED WATER OUTAGES

- A. Under no circumstances shall water be shut off to any active service in the course of new construction without written permission from the City of Bryant. If water pressure needs to be reduced to facilitate construction, a preconstruction meeting shall be held. The work shall be performed as described in Section 4200 – Water Line Pressure Reduction Procedures.

1.27 PROTECTION OF WATER SUPPLIES

- A. There shall be no physical connections between a public or private water supply system and a sanitary sewer or appurtenances thereto which would permit the passage of any polluted water into the potable supply. Sanitary sewers shall be installed at least ten (10) feet horizontally from any existing or proposed water line. The distance shall be measured edge to edge. In cases where it is not practical to maintain a ten (10) foot separation, the appropriate reviewing agency may allow deviation on a case-by-case basis if supported by data from the design engineer. Such deviation may allow installation of the sewer closer to a water main provided that the water main is in a separate trench or on an undisturbed earth shelf located to one side of the sewer, and at an elevation so the bottom of the water main is at least 18-inches above the top of the sewer.
- B. Sewer lines installed under a water line must have a clear distance between pipes of at least eighteen (18) inches.
- C. The sewer line shall be installed such that a joint of pipe is centered along the water line and the joints are as far as possible from the water line.
- D. If 18-inches of clearance cannot be provided or when the water main must pass under the sewer main, either the sanitary sewer main or the water main shall be encased in twenty (20) feet of watertight encasement pipe, centered over the point of crossing. Crossings that are not perpendicular will require more than twenty (20) feet of encasement. The encasement shall extend a minimum of ten (10) feet perpendicular from the outside edges of the line that is not being encased. The ends of the encasement pipe shall be sealed watertight. Refer to Section 3400 – Steel Encasement Pipe for end seals.

1.28 EXISTING UTILITY STRUCTURES AND FACILITIES

- A. The drawings shall show the location of overhead and underground utility lines and existing water and sewer lines according to the best information presented and available. Drawings shall be submitted to the utilities and shall have indicated to the best of their records the locations of their facilities and the route of the proposed water line.

1.29 UTILITY COORDINATION

- A. It is the responsibility of the Owner or his authorized representative to coordinate with and get approval from the various Utilities, including other Departments of the City. Further, it is the responsibility of the Owner to get authorization to encroach upon any other utilities' easement(s) and secure such recorded encroachment as a requirement for dedication of the water system.

1.30 DRAFTING STANDARDS

A. GENERAL

These standards have been established for the purpose of ensuring uniformity in the design and drafting techniques of projects to be submitted for review and acceptance.

1. All projects submitted shall have a title sheet which shall include:

- a. General overall area map;
 - b. Vicinity location map;
 - c. A site plan map detailing the project;
 - d. Name/title of project including section number if applicable;
 - e. Owner and Engineer's name; and
 - f. Professional Engineer's seal and signature.
2. All plan and profile sheets are to be certified and dated by a professional engineer of the State of Arkansas.
 3. All sheets are to be numbered, with total number of sheets included; i.e., sheet 4 of 12.
 4. Include detail sheet(s)/specification sheet(s), as applicable.
 5. Design drawings shall be 22-inch by 36-inch, or 24-inch by 36-inch.

B. SCALES

The following scales for drawings are required:

1. Plan and profile: variable; not to exceed
 - 1" = 50' horizontal
 - 1" = 10' vertical
2. Cross sections: 1" = 10' horizontal and vertical.

C. LETTERING

Minimum sizes for lettering shall be:

1. Titles: 1/4" or larger.
2. General: 1/8" or larger.

D. MATERIALS

High quality bonded paper shall be used for all originals and reproduction "originals" to be submitted as record drawings. Any drawing deemed not usable by the Public Works Director will be rejected.

E. ORIENTATION

Drawings shall be situated so that north is either toward the top or toward the right side of the sheet. The north arrow shall be clearly visible.

F. PLAN AND PROFILE DRAWINGS

All plan sheets shall include the following information when applicable:

1. A north arrow;

2. The scales used;
3. Project name and number, sheet number, date drawn, date and nature of revisions;
4. All topography in the area affected by construction;
5. Right-of-way lines, property lines and easements;
6. Locations of benchmarks and their descriptions;
7. Locations of all existing and proposed utilities in the project area; and
8. Match lines shall be easily identifiable.

All profiles shall include the following:

1. Existing and finished grade lines;
2. Size and type of pipe;
3. Elevations to USGS datum;
4. Profile of existing and proposed utilities; and
5. Special construction required due to unfavorable soil conditions.

G. USE OF STANDARD SYMBOLS AND NOTATIONS

1. Water plans shall be prepared using standard symbols and notations commonly used in the practice of civil engineering. If necessary, legends shall be provided to define the symbols used.
2. At a minimum the following symbols shall be used:
 - a. FH – Fire Hydrant
 - b. WM – Water Meter
 - c. GV – Gate Valve
 - d. BFV – Butterfly Valve
 - e. WV – Water Valve (unknown type)
 - f. WL-x – Water Line where x identifies diameter in inches
 - g. SS-x – Sewer Line where x identifies diameter in inches
 - h. FL-x – Fire Lines where x identifies diameter in inches

1.31 RECORD DRAWINGS

A. DATUM REQUIREMENTS

1. Horizontal Datum: NAD83 (1986) Arkansas State Plane, North Zone, US foot (Grid System).
 2. Vertical Datum: NAVD88 (feet)
- B. TOLERANCES
1. Horizontal: +/- 0.5 feet
 2. Vertical: +/- 0.05 feet
- C. Water drawings submitted as record ("as-built") drawings shall indicate the location where the water line was installed and have the following items surveyed during/after construction and shown on the drawings:
1. Fire hydrant, location and top operating nut elevation
 2. Water valves, location
 3. Water fittings, location
 4. Water service saddle, location
 5. Water service saddles used for testing, location
 6. Water meters, location
 7. Tapping sleeves, location
 8. Any other pipe penetrations, location
 9. Steel encasements, location
 10. Details shall be provided for all vertical offset water lines, profile drawing
- D. Manufacturing data shall be collected for pipe, valves, and hydrants as follows:
1. Pipe
 - a. Manufacturer
 - b. Material (DI or PVC)
 - c. Diameter
 - d. Production run code or lot code
 2. Valves
 - a. Manufacturer
 - b. Model number
 - c. Year manufactured
 - d. Type (gate, butterfly, ball)

- e. Diameter
3. Hydrants
- a. Manufacturer
 - b. Model number
 - c. Year manufactured
 - d. Depth of bury, including extensions
- E. All sheets shall have the phrase "as-built" or "record drawing" boldly printed on them with the as constructed date, and shall be stamped and signed by a professional engineer registered in the State of Arkansas. Record drawings shall be submitted in hard copy, .dwg electronic format, and .pdf electronic format.

1.32 INSPECTIONS AND TESTING PROCEDURES

- A. All field tests required for a project shall be witnessed by the City in the presence of the Engineer of Record or his authorized representative and the Contractor.
- B. The City requires a 24 hour working day notice on all tests. Calls to the City for the purpose of setting test times shall be made by no later than 10:00 AM for test on the following work day.
- C. Tests delayed by weather or other factors will be rescheduled on the same basis. If a test cannot be reasonably scheduled so that a representative of the City can be present, the Engineer of Record will witness the test and certify to the City the results.
- D. In no case shall a test be made without the presence of the Engineer of Record and the Contractor. It is the responsibility of the Engineer of Record and/or the Contractor to coordinate the scheduling of tests with the City and with the other parties involved.
- E. The tests generally associated with water line construction are:
 - 1. Pressure testing of tapping sleeve installations
 - 2. Pressure testing of lines after installation
 - 3. Disinfection
 - 4. Bacteriological (Bac-T) testing
 - 5. Fire hydrant flow testing
 - 6. Trace wire continuity testing
- F. Generally, no Contractor or Engineer of Record involvement is required in the taking of samples for the Bac-T test except that the Contractor is responsible for the proper flushing of the line prior to samples being taken by the City. However, the City may require the presence of the Contractor or Engineer of Record when questions have been raised as to the methodology or techniques used in the sampling process.

- G. Bac-T samples are sent to the Arkansas Department of Health for testing. Results obtained by the City shall be forwarded to the Engineer of Record either by email, fax, or mail upon receipt by the City.
- H. Lines failing the Bac-T tests shall be re-sampled as soon as practicable. If a line fails two (2) consecutive Bac-T tests, the line must be re-chlorinated before Bac-T samples can be taken again. The City shall not be responsible for rescheduling Bac-T tests.
- I. The fire hydrant test shall consist of checking the operation of the fire hydrant valve and flowing the fire hydrant. This shall be done after the pressure test has been completed. The fire hydrant valve shall be left in the open position during the test and after the test is completed.
- J. All equipment, materials, and labor required for testing shall be furnished by the Contractor at his expense.

1.33 FINAL ACCEPTANCE BY THE CITY

- A. The City will be deemed to have accepted water lines and appurtenances for ownership upon completion of the following.
 - 1. Acceptable Final Inspection by the following:
 - a. A representative of the City Engineer's Office
 - b. A representative of the Bryant Water and Sewer Department
 - c. The Engineer of Record
 - d. The Contractor
 - 2. Acceptable walk-through by the City for location, grade, and condition of water meter settings
 - 3. Construction Cost is received by the City
 - 4. Record Drawings are received by the City:
 - a. Two (2) full-size sets of paper drawings
 - b. One (1) CD with electronic versions of the drawings, in both .pdf and AutoCAD versions.
 - 5. Engineer of Record Certification is received by the City
 - 6. Letter of Acceptance is granted by the City
- B. No water meter shall be set until all final acceptance requirements are met and the line is accepted in writing by the City.

1.34 APPLICABILITY

- A. These regulations and requirements contained in these Standard Specifications shall be applicable to all land or parcels of land being developed for commercial, industrial, or residential use. The material and construction specifications shall be applicable to all water line construction under the control of the City of Bryant.

END OF SECTION 1100

SECTION 1200

GENERAL DESIGN STANDARDS - SEWER

PART 1 – GENERAL

- A. Construction permits shall be obtained from the Code Enforcement/Permits Office for the installation of all sanitary sewer facilities discharging into the Bryant Sanitary Sewer System in accordance with the City Ordinance. Sanitary sewer facilities shall be designed and installed in accordance with the Standard Specifications for Design and Construction of Water Lines and Sewer Lines.

1.01 REQUIREMENTS TO EXTEND SEWER SERVICE

- A. All new development of any kind shall be required to extend sewer services to that development at the owner's expense. Sewer lines shall be extended to each property to be served by City of Bryant sewer. This includes all new developments, infill projects, and lot splits.
- B. Sewer service lines shall extend perpendicular to the sewer main and extended to the property being served.

1.02 PROTECTION OF EXISTING SEWER SYSTEM

- A. Only authorized personnel from the City of Bryant Water and Sewer Department are permitted to operate valve, pumps, etc. on the existing sewer system. Under no circumstance shall the Contractor operate any valve or pump on the existing sewer system.

1.03 DESIGN CRITERIA

A. GENERAL

All sanitary sewers shall be designed to carry the estimated flow from the area ultimately contributing to the respective reach of the sanitary sewer. The required capacity shall either be established by the City or at the City's option by means of a basin study developed by the Owner or his authorized engineer/designer. In no instance shall a gravity sewer, other than a building sewer, be less than eight (8) inches in diameter. The following design standards for gravity sewers within or contributing to the City of Bryant Sanitary Sewer System have been established:

1. Population Density

Population density shall be in accordance with the Comprehensive Plan for Bryant projected by the Division of Planning for the City of Bryant or actual count or character of proposed development, whichever is greatest.

2. Average Family

For the purposes of design the average family unit is considered to be 3.0 persons per single family home.

3. Design Flow

The design of all sanitary sewer facilities shall be based on future area population growth and land development characteristics provided by the Department of Planning including the servicing of existing contiguous developed areas not currently served by sanitary sewers. The values of Average and Peak Flow and Design Population hereby shall be the

values which include the future flows and population. The City reserves the right to review and determine the appropriateness and/or applicability of the estimated flow volumes provided.

The following shall be used as a guide:

a. Average Design Flows

- 1) Single Family Residential: The average design flow for single family dwellings shall be one hundred (100) gallons per person per day.
- 2) Commercial/Industrial/Institutional: Based upon information either submitted by the Owner or developed by the City. These flow volume guidelines may be modified at the City's discretion.

b. Peak Design Flow

- 1) Single Family Residential: The peak design flow for a single family development shall be calculated as follows:

$$Peak\ Flow = (Avg.\ Flow) \left[\frac{18 + \sqrt{P}}{4 + \sqrt{P}} \right]$$

Where P is equal to the total Design Population in thousands.

- 2) Commercial/Industrial/Institutional: The peak design flow from commercial, industrial or institutional developments shall be the average daily flow determined multiplied by 2.5. **The peak design flow shall not be less than 90% of the peak water demand or exceed the flow limits of the water meter supplying the facility.**

4. Design Capacities: Collector and trunk sewers shall be designed on the following basis:

a. Collector Sewers Twelve (12) Inches and Smaller

Peak design flow capacities shall be based on sewers flowing 90% full.

b. Trunk Sewers Fifteen (15) Inches and Larger

Peak design flow capacities for trunk or interceptor sewers shall be based on sewers flowing 90% full, without head, using the design population density and appropriate land use determined by the Division of Planning; and shall include an allowance for infiltration which will be reviewed on a case-by-case basis and is subject to the approval of the City.

1.04 MINIMUM PIPE SIZES AND STANDARDS

A. PIPE DIAMETER

1. The required diameter of gravity sewers shall be determined by Manning's formula using a roughness coefficient, "n" of 0.013 or the pipe manufacturer's recommendation, whichever is greater. The minimum pipe diameter for gravity sewers lines shall be eight (8) inches.

B. MINIMUM SLOPES AND VELOCITIES

1. All sanitary collector and trunk sewers shall be designed and constructed to provide a minimum velocity when flowing full of two (2) feet per second. The slope of the sewer pipe shall be such that these minimum velocity requirements are attained. The minimum acceptable slopes for the design and construction of sanitary sewers are as follows:
2. THESE ARE MINIMUM SLOPES REQUIRED OF THE DESIGN. AS CONSTRUCTED SANITARY SEWERS FOUND TO HAVE LESS THAN THIS MINIMUM SLOPE SHALL NOT BE ACCEPTED.

Pipe Size * (inches)	Minimum Slope (Feet per 100 Feet, %)
8	0.40
10	0.28
12	0.22
15	0.15
18	0.12
21	0.10
24 and greater	0.08

*4" and 6" lines are allowed for building sewers only. For details see UPC (Uniform Plumbing Code), latest edition.

C. MINIMUM DEPTH

1. For the protection of the sanitary sewer lines from damage caused by utilities installed after the sanitary sewer has been constructed, the minimum depth to crown of all gravity sanitary sewers shall be 3.0 feet, and the minimum depth to crown of all force main sanitary sewers shall be 3.0 feet.

D. BUILDING SEWERS

1. Building sewers shall conform to the latest edition of the Uniform Plumbing Code and to these Standards.
2. The building sewer shall connect to the public sewer at a mainline fitting. **Sewer service connections shall be made on 12-inch and smaller sewer lines.** Connections to manholes shall only be allowed at upstream terminating manholes or by approval of the City. Inside drop connections to manholes are only allowed under extenuating circumstances at the discretion of the City of Bryant.
3. Building sewers requiring a 6-inch or larger sewer connection shall be connected at a manhole. If an existing manhole is not available, a new manhole must be constructed.
4. Homes or buildings where the lowest elevation to have gravity sewer service is less than 1 foot above the cover of either the first upstream or downstream manhole on the sewer

main shall have a cleanout with a pop-up type, non-locking cover at an elevation no less than 6-inches below the lowest sanitary facility in the structure.

5. Homes or buildings with a slope from the lowest sanitary facility to the public sewer main less than 1 percent shall be served with a pump system. The system shall be purchased, installed, and maintained by the owner. If the pump system is manufactured by Environment One (E-One) Corporation, the City of Bryant will maintain the pump system. At the discretion of the City of Bryant, a maintenance fee may be required.
6. Building sewers within the right-of-way or easement shall be a minimum of four (4) inches in diameter. Building sewers shall have a wye cleanout located within three (3) feet of the building's exterior wall and extended to 3-inches above grade and shall have a watertight, removable cap.
7. Cleanouts installed under concrete or asphalt paving shall be made accessible by a short bodied cast iron valve box.
8. Building sewers installed for future connections shall be terminated at the right-of-way or easement and plugged to ensure 100 percent water tightness. Mark wyes for future connections using marking tape, tracer wire, yellow nylon rope, and 1/2" x 4' rebar or fence tee-post.

1.05 SEWER LINE MATERIALS

- A. Materials for sewer line mains shall be PVC unless approved by the City of Bryant or otherwise indicated in these specifications.

1.06 LOCATION OF SEWER LINES

- A. Sewer lines shall be placed on public streets either in the right of way or in an easement adjacent to the street right of way except that lines can go between lots when there is no other reasonable way to access a line or provide for future service. Sewer lines located in easements behind houses without a dedicated, paved alley shall have the manholes located adjacent to the nearest street right-of-way.
- B. Sewer lines shall be located a minimum of 36-inches from any other parallel utilities or structures.

1.07 SEWER STRUCTURES

A. MANHOLES

1. General

- a. Manholes shall be installed at the end of each line; at all changes in grade, size, materials or alignment; at all sewer intersections and at the following intervals:

Pipe Diameter (inches)	Maximum Interval Between Manholes (feet)
8 to 18	400
21 and larger	500

- b. Manholes shall be located such that they are readily accessible to sewer cleaning equipment. Sewer mains located in easements behind houses without a dedicated, paved alley shall have the manholes located adjacent to the nearest street right-of-way.
- c. The minimum inside diameter of manholes shall be as stated in Section 3300-Manholes.
- d. Flow channels shall be shaped and formed in each manhole to provide a smooth transition of flow from all inlets to the outlet. The bench wall shall be formed from the center of the manhole to the outlet pipe in the shape of a "U" as shown in the Standard Details.
- e. At changes in sewer alignment and/or sizes, the energy gradient elevation shall not increase. This shall be accomplished by keeping the crown elevation continuous where possible for changes in sewer sizes.
- f. Connections to manholes on trunk sewer lines shall be installed at such elevations that will not cause a backup in the collector sewer. Trunk sewers are designed to flow completely full during peak operation. Therefore, connections should not be made below the crown of the trunk sewer line pipe.
- g. Minimum drop across the manhole from inlet invert to outlet invert shall be 0.10 feet.
- h. Manholes proposed to be installed in unpaved areas shall be designed and constructed such that the top of the casting is a minimum of three (3) inches and a maximum of five (5) inches above the finished grade to prevent ponding of water over the casting. Positive drainage away from the manhole shall be provided.
- i. Manholes constructed within a 100-yr floodplain shall be constructed such that the rim elevation is a minimum of 2-feet above the flood elevation or be constructed with hinged and gasketed covers. Manholes that are within the 100-yr floodplain and also within the ROW shall have hinged and gasketed covers.
- j. Manholes located on 15-inch and larger sewer lines or manholes on sewer lines within 100 feet of a 15-inch and larger sewer line shall be epoxy coated on the interior after the manhole is installed. Refer to Section 3300 Manholes for epoxy lining requirements.
- k. Manholes within a pump station site shall be epoxy coated on the interior after the manhole is installed. Refer to Section 3300 Manholes for epoxy lining requirements.
- l. Manholes in which a force main discharges into shall be epoxy coated on the interior after the manhole is installed. If a new force main connects to an existing manhole that is not epoxy coated then the existing manhole shall be epoxy coated after the force main is installed. Refer to Section 3300 Manholes for epoxy lining requirements.
- m. All manholes not included in item j, k or l above shall be coated with Carboline Bitumastic 300 M, or approved equal. Manholes may be coated before or after installation.

2. Outside Drop Connections

- a. Outside drop pipe connections shall be provided for all sanitary sewers entering a manhole at an elevation greater than twenty-four (24) inches above the invert of the manhole.
- b. In areas where future residential, commercial, and/or industrial growth can occur, all new manholes 15 feet deep or deeper shall be equipped with up to two (2) outside drop connections of a size and at an elevation to be determined by the City at the time of design to allow for future connections at these points. The drops shall extend from the base to within 10 feet of the final graded surface elevation.

NOTE: THIS SHOULD NOT IMPLY THAT EVERY MANHOLE SHALL BE PROVIDED WITH 2 OUTSIDE DROP CONNECTIONS.

B. SEWER PUMP STATIONS

1. If requested by the City, an economic analysis shall be provided that proves to the satisfaction of the City that a pump station exhibits a lower 20-year life cycle cost than extending a gravity sewer to the development.
2. The analysis shall be per latest standard practice for least cost (life cycle) as developed by ASTM C1131 and evaluate labor costs, maintenance costs (including parts replacements), operation costs and rehabilitation costs. The analysis shall take into consideration both interest and inflation rates.
3. The following minimum assumptions shall be made when calculating life cycle costs.
 - a. Pump Station Construction Costs = Actual cost
 - b. SCADA System = \$7,500
 - c. Pump Station Routine O&M labor = 50 hrs/year @ \$40/hr
 - d. Effective Energy Costs = \$0.25/kW·hr
 - e. Interest Rate = 5%
 - f. Inflation Rate = 3%
 - g. Replace pumps in year 11
4. In the event that a pump station is more cost effective than gravity sewer, the operation and maintenance expenses for the pump station must be paid in addition to the monthly sewer service charges paid by the benefiting customers. The Developer must pay, in advance, the present value of the estimated operation and maintenance costs for the estimated service life of the pump station. The estimated service life shall be 20 years.
5. If a pump station is more cost effective, the City of Bryant reserves the right to cost share with the developer to pay for a gravity sewer extension in lieu of a pump station.

1.08 EASEMENTS AND DEEDS

A. GENERAL

1. Whenever possible, sanitary sewers shall be constructed within the public right-of-way. Should the construction be outside the limits of the public right-of-way, recorded sewer easements shall be acquired, dedicated and recorded solely for the benefit of the City. Easement boundaries shall be so shown on the plans and specifications as "Water and Sewer Easement" in lieu of "Utility Easement". Sanitary sewers may be constructed within "platted" utility easements if the work is performed in conjunction with a development approved by the City.
2. The minimum permanent easement widths to be dedicated to the City are as follows:

Depth of Sewer from Finished Grade	Easement (ft)
Up to 10 feet	20
> 10 feet to 20 feet	25
Greater than 20 feet	30

3. All sanitary sewers shall be centered in the easement. For those sanitary sewers constructed in the public right-of-way, the easement shall extend the distance outside the right-of-way necessary to provide the required easement width. Sewers not centered in the easements shall have an easement width equal to 1/2 that designated above on each side of the easement.
4. A minimum 50 foot by 50 foot deeded property shall be provided for all submersible lift stations with wet wells up to 20 feet deep. Deeds for lift stations with wet wells greater than 20 foot deep and/or wet well/dry pit lift stations shall be handled on a case by case basis.
5. The sewer easements shall be exclusively under the discretion and control of the City. Ingress and egress shall be available to the City's crews at all times. No utility companies are allowed to use the sewer easements for installation of their utility lines without the expressed written permission of the City. All plan sheets shall clearly identify the sanitary sewer easement and the location of all other proposed utilities. The horizontal and vertical plans shall identify all utilities proposed to cross the sanitary sewer easement.

1.09 DRAFTING STANDARDS

A. GENERAL

These standards have been established for the purpose of ensuring uniformity in the design and drafting techniques of projects to be submitted for review and acceptance.

1. All projects submitted shall have a title sheet which shall include:
 - a. General overall area map;
 - b. Vicinity location map;
 - c. A site plan map detailing the project;
 - d. Name/title of project including section number if applicable;
 - e. Owner and Engineer's name; and

- f. Professional Engineer's seal and signature.
2. All plan and profile sheets are to be certified and dated by a professional engineer of the State of Arkansas.
3. All sheets are to be numbered, with total number of sheets included; i.e., sheet 4 of 12.
4. Include detail sheet(s)/specification sheet(s), as applicable.
5. Design drawings shall be 22-inch by 36-inch, or 24-inch by 36-inch.

B. SCALES

The following scales for drawings are required:

1. Plan and profile: variable; not to exceed
 - 1" = 50' horizontal
 - 1" = 10' vertical
2. Cross sections: 1" = 10' horizontal and vertical.

C. LETTERING

Minimum sizes for lettering shall be:

1. Titles: 1/4" or larger.
2. General: 1/8" or larger.

D. MATERIALS

1. High quality bonded paper shall be used for all originals and reproduction "originals" to be submitted as record drawings. Any drawing deemed not usable by the Public Works Director will be rejected.

E. ORIENTATION

1. Drawings shall be situated so that north is either toward the top or toward the right side of the sheet. The north arrow shall be clearly visible.

F. PLAN AND PROFILE DRAWINGS

All plan sheets shall include the following information when applicable:

1. A north arrow;
2. The scales used;
3. Project name and number, sheet number, date drawn, date and nature of revisions;
4. All topography in the area affected by construction;
5. Right-of-way lines, property lines and easements;

6. Locations of benchmarks and their descriptions;
7. Locations of all existing and proposed utilities in the project area; and
8. Match lines shall be easily identifiable.

All profiles shall include the following:

1. Existing and finished grade lines;
2. Inverts at all manholes;
3. Length and size of pipe between manholes;
4. Slope of pipe in percent;
5. Elevations to USGS datum;
6. Top of casting elevations;
7. Types of materials used;
8. Profile of existing and proposed utilities; and
9. Special construction required due to unfavorable soil conditions.

G. SEWER PUMP STATION DRAWINGS

Sewer pump station drawings shall, at a minimum, contain the following:

1. At least two views of the station, plan view and cross section;
2. Electrical panel detail;
3. All electrical designs shall be sealed by a licensed electrical engineer;
4. Pump and alarm control elevations;
5. Inlet and outlet pipe elevations;
6. Finished grade and foundation elevations;
7. Special construction required due to unfavorable soil conditions;
8. Design pump capacity, rated horsepower, total dynamic head, manufacturer and model number;
9. Wetwell capacity and cycle time;
10. Also, the Engineer shall submit a copy of the head discharge curve and the complete design calculations for the lift station and force main; and
11. Fence and access drive detail.

H. USE OF STANDARD SYMBOLS AND NOTATIONS

1. Sanitary sewer plans shall be prepared using standard symbols and notations commonly used in the practice of civil engineering. If necessary, legends shall be provided to define the symbols used.

1.10 RECORD DRAWINGS

A. DATUM REQUIREMENTS

1. Horizontal Datum: NAD83 (1986) Arkansas State Plane, North Zone, US foot (Grid System).
2. Vertical Datum: NAVD88 (feet)

B. TOLERANCES

1. Horizontal: +/- 0.5 feet
2. Vertical: +/- 0.05 feet

C. Sanitary sewer drawings submitted as record ("as-built") drawings shall indicate the location where the sewer line was installed and have the following items surveyed during/after construction and shown on the drawings:

1. Manholes, location and rim elevation
2. Pipe material, diameter, and invert elevations
3. Sewer main percent slope (calculated and setting from pipe laser)
4. Lateral connections. Lateral measurements shall be indicated by their distance from the downstream manhole in the form of stationing. Lateral stationing shall begin at 0+00 at each downstream manhole.
5. Location of capped service lines
6. Cleanouts (if installed during construction)
7. Location of fittings, valves, and valve boxes on force mains
8. Location of steel encasements
9. TV video (DVD format) and logs shall be delivered to the City of Bryant. Video shall play in a standard DVD player without the need of viewing software.

D. All sheets shall have the phrase "as-built" or "record drawing" boldly printed on them with the as constructed date, and shall be stamped and signed by a professional engineer registered in the State of Arkansas. Record drawings shall be submitted in hard copy, .dwg electronic format, and .pdf electronic format.

1.11 PROTECTION OF WATER SUPPLIES

- A. There shall be no physical connections between a public or private water supply system and a sanitary sewer or appurtenances thereto which would permit the passage of any polluted water into the potable supply. Sanitary sewers shall be constructed at least ten (10) feet horizontally from any existing or proposed water line. The distance shall be measured edge to edge. In cases where it is not practical to maintain a ten (10) foot separation, the appropriate reviewing agency may allow

deviation on a case-by-case basis if supported by data from the design engineer. Such deviation may allow installation of the sewer closer to a water main provided that the water main is in a separate trench or on an undisturbed earth shelf located to one side of the sewer, and at an elevation so the bottom of the water main is at least 18-inches above the top of the sewer.

- B. Sewer lines installed under a water line must have a clear distance between pipes of at least eighteen (18) inches.
- C. The sewer line shall be installed such that a joint of pipe is centered along the water line and the joints are as far as possible from the water line.
- D. If 18-inches of clearance cannot be provided or when the water main must pass under the sewer main, either the sanitary sewer main or the water main shall be encased in twenty (20) feet of watertight encasement pipe, centered over the point of crossing. Crossings that are not perpendicular will require more than twenty (20) feet of encasement. The encasement shall extend a minimum of ten (10) feet perpendicular from the outside edges of the line that is not being encased. The ends of the encasement pipe shall be sealed watertight. Refer to Section 3400 – Steel Encasement Pipe.

1.12 EXISTING UTILITY STRUCTURES AND FACILITIES

- A. The drawings shall show the location of overhead and underground utility lines and existing sewers according to the best information presented and available. Drawings shall be submitted to the utilities and shall have indicated to the best of their records the locations of their facilities and the route of the proposed sewer.

1.13 UTILITY COORDINATION

- A. It is the responsibility of the Owner or his authorized representative to coordinate with and get approval from the various utilities, including other Departments of the City. Further, it is the responsibility of the Owner to get authorization to encroach upon any other utilities' easement(s) and secure such recorded encroachment as a requirement for dedication of the sanitary sewer system.

1.14 STEEL ENCASEMENTS

- A. Sanitary sewers shall be encased in steel encasement pipe wherever the sanitary sewer crosses under, through, or over a drainage way (i.e. creeks, rivers, streams, concrete channels, concrete storm drains, or any storm drain 30-inch diameter and larger, or all storm drains with multiple pipe runs). Wherever applicable, the sanitary sewer crossing the drainage way shall be pressure tested to assure 100 percent water tightness prior to backfilling.
- B. Sewer lines through steel encasement shall be installed with three spacers per joint such that the spacers are equally spaced along the length of the pipe.
- C. End Seals shall be used on all encasement pipes.

Attachment to Section 1200

WASTEWATER FLOWS*

Type of Establishments *	Gallons Per Person Of Wastewater Per Day Unless Otherwise Noted
1. Institution other than hospitals	180 - 120
2. Schools (without gym and showers)	15
3. Schools (with gyms and showers)	25
4. Organization camps only	
a. With showers and hand washing facilities	20 +
b. With toilets, showers, and hand washing facilities + Cooking or central food service included.	40 +
5. Campgrounds	
a. With individual sewer connections (per site)	100
b. With community building only (per site)	50
6. Mobile home parks (per mobile home park space)	200
7. Motels and hotels (per room)	100
8. Restaurants along an interstate or major highway; 24 – hour operation (per seat)	70
9. Restaurants; 24 – hour operation (per seat)	50
10. Restaurants; less than 24 – hour operation (per seat)	35
11. Bars and cocktail lounges (per seat)	35
12. Bowling alleys (per alley)	100
13. Places of employments (does not include industrial waste, per employee per shift)	15 - 35
14. Day workers at offices	15
15. Picnic parks and areas	5
16. Drive-in theaters (per ramp parking space)	7
17. Service stations (per vehicle served)	10
18. Swimming pool bathhouse (per person)	10
19. Private dwelling (per dwelling)	300
20. Apartments	
a. One bedroom (per apartment)	200
b. Two bedroom or more (per bedroom)	150

21. Shopping center (where stores are not known) per square foot building area	.45
22. Churches	
a. Without kitchen (per sanctuary seat)	3
b. With kitchen (per sanctuary seat)	5
23. Beauty Salon	35
24. Day Care Center	20

* The flows listed indicate a reasonable approach for the type of establishment referred to. Additional considerations will be necessary in some cases.

For uses not mentioned in this table, flow estimates should be submitted for preliminary design review and possible approval prior to proceeding with final plans.

END OF SECTION 1200

SECTION 2000

TRENCH SAFETY

PART 1 - GENERAL

1.01 WORK INCLUDED

- A. The Contractor is responsible for ensuring that safe working conditions exist and safety procedures are being followed at the work site. The Contractor is responsible to notify OSHA of the commencement of all water or sewer construction.
- B. If the Contractor is working for any public body (state agency, county, municipality, school district, or other local tax unit or improvement district), they shall be responsible for notifying the Arkansas Department of Labor Safety Division, (501) 682-9091 when water or sewer construction jobs are to begin. A copy of a letter or reporting form shall be sent to the City of Bryant Public Works Director.
- C. Regarding Trench Safety Systems, the Contractor shall design, install, and maintain a "Trench Safety System" in strict compliance with OSHA (Occupational Safety and Health Administration) Part 1926 of the Code of Federal Regulations and all other applicable federal, state, and local requirements.

END OF SECTION 2000

SECTION 2100**EROSION AND SEDIMENT CONTROL****PART 1 – GENERAL****1.01 WORK INCLUDED**

- A. The Contractor shall accomplish temporary and permanent erosion protection related to grubbing, grading, excavation, paving, and other work as directed by the Engineer and as shown on the approved drawings. An erosion control plan shall be submitted to the Engineer prior to the commencement of construction.
- B. The Contractor is responsible for implementing Best Management Practices (BMPs) during construction activities, (including, but not limited to, sediment and erosion control structures) and achievement of final stabilization upon completion of construction activities.
- C. The Contractor shall be responsible for implementing all applicable requirements of the ADEQ General Stormwater Permit for Construction Activity, the Spill Prevention Control and Countermeasures Plan (SPCCP), as required by USEPA, local Municipal Separate Storm Sewer requirements, and all other environmental regulatory requirements that are associated with the construction activities that they are contracted to perform. The Contractor is responsible for managing all materials, equipment, and activities at the work site in a manner that is in compliance with local, State, and Federal environmental regulations.

PART 2 – PRODUCTS

- A. Not used

PART 3 – EXECUTION**3.01 TEMPORARY EROSION CONTROL**

- A. The Contractor shall construct temporary berms, dikes, dams, ditching or sediment basins, and maintain such control features until permanent erosion control features are placed all in accordance with the City or State "Erosion Control Standards".

3.02 SILT FENCES

- A. Silt Fences: In areas where silt fencing is required, Contractor shall use the following installation specifications:
 - 1. Posts for silt fences shall be 2-inch diameter pine, 2-inch diameter oak, or 1.33-lb/linear ft. steel with a minimum length of 3 feet.
 - 2. Contractor shall use silt fence geotextile fabric specifications, in accordance with Section 625 of the Arkansas 2003 Standard Specifications for Highway Construction: Type 3 or Type 4. Only those fabric types specified for use as silt fence by the manufacturer shall be used.
 - 3. Filter fabric shall be stretched and securely fastened to the fence with wire fasteners, staples, or preformed clips.
 - 4. Fabric shall be attached to “upgradient” side of posts to prevent stormwater flow from tearing fabric from posts.

5. All silt fences shall be installed at level grade following contours. Both ends of each fence section shall be extended at least 8 feet upslope at 45 degrees to the main fence alignment to allow for pooling of water and prevent stormwater runoff from flowing around end of silt fence.
6. Ends of a silt fence shall be tied into the landscape to prevent flow around the end of the fence before the pool reaches design level. Contractor shall provide stabilized outlets to protect the fence system and release storm flows that exceed the design storm. At fabric ends, both ends shall be overlapped a minimum of 6 inches, folded, and secured to the fence. The fabric toe should be placed in the bottom of the trench, backfilled, and compacted.
7. Contractor shall be responsible for maintenance of silt fences. Silt accumulations shall be removed before they reach 1/3 of the silt fence height. Silt fences shall be replaced, as necessary, should they fail to achieve adequate sedimentation control.
8. Contractor shall ensure that the depth of impounded water does not exceed 1.5 feet at any point along the silt fence.
9. The design life of a synthetic silt fence should be approximately 6 months.
10. The slope length is the distance from the fence to the drainage divide or the nearest upslope channel. The maximum slope length above silt fence shall not exceed the following dimensions:

Slope - Percent	Maximum Slope Length (ft) Above Fence	
	18 - Inch High Fence	30 - Inch High Fence
2 (or less)	150	500
5	100	250
10	50	150
15	35	100
20	25	70
25	20	55
30	15	45
35	15	40
40	15	35
45	10	30
50	10	25

11. “Super” silt fence with chain-link fencing or 2-inch by 4-inch wire backing shall be used to control runoff from small disturbed areas where the maximum slope lengths for standard 18-inch or 30-inch silt fence cannot be met and sufficient room for construction of sediment traps or basins does not exist.
12. “Super” silt fence shall not be used in areas where rock or rocky soils prevent the full and uniform anchoring of the fence or proper installation of the fence posts. It shall be used only where access exists or can be made for the construction equipment required to install and remove the fencing.
13. Wire reinforcement for “super” silt fence shall be a minimum 14 gauge and a maximum mesh spacing of 4 inches.

14. The maximum slope length above any “super” silt fence should not exceed the following dimensions:

Slope Percent	Maximum Slope Length (ft)
2 (or less)	1,000
5	500
10	300
20	200
30	100
40	75
50	50

15. Poles for “super” silt fence shall be 2.5-inch diameter galvanized or aluminum posts, or 4 feet long steel “T-posts”, set at 6-foot maximum spacing. Poles shall be driven a minimum 18 inches below the ground surface and extend a minimum of 30 inches above the ground surface.
16. The “super” silt fence shall be entrenched into an 8-inch deep trench and the disturbance on the downslope side shall be minimized. The bottom of the trench should be at level grade. Maximum deviation from level grade should be 5 percent, and not extend for more than 50 feet, where practicable.
17. “Super” silt fence shall be installed at level grade. Both ends of each fence section shall be extended at least 8 feet upslope at 45 degrees to the main fence alignment to allow for pooling of water.
18. Silt fence shall be installed so as to serve a 10-year peak storm event. A 10-year, 24-hour peak storm event equates to approximately 5 inches of rainfall, resulting in 2.3 inches to 4.9 inches of runoff.
19. Silt accumulations shall be removed before they reach 1/3 of the silt fence height.

3.03 STRAW BALE CHECK DAMS

- A. According to the EPA BMP Manual, the use of hay bales in concentrated flow areas is not recommended as a best management practice.
- B. Contractor shall use straw bale check dams only where the following conditions apply:
1. Where contributing area is approximately 1/2 acre, or less.
 2. Where there is not concentration of water in a channel above the barrier.
 3. Where length of slope above the barrier is less than 100 feet.
 4. Where straw bales are used in conjunction with silt fence.
- C. Straw bales shall not be used on high silt producing areas, above high-risk areas, where water concentrates, or where there would be a possibility of a washout.

- D. Straw bales shall not be used in excess of a three-month time period. If construction continues beyond this time period, the existing straw bales shall be replaced with new bales.
- E. Contractor shall install straw bales to the following specifications:
 - 1. Anchors shall be No. 5 reinforcing bars, 2 inch x 2 inch oak stakes, or steel pickets.
 - 2. A trench shall be excavated along the areas where straw bales will be used to a depth of 4 inches and to the width of one straw bale. The straw bales then shall be placed in the trench with excavated material placed on upgradient side of the check dam and compacted.
 - 3. Straw bales shall be anchored with a minimum of 2 stakes or rebars per bale, driven into the underlying soil, making sure that the binding wire or twine is facing the sides and not touching the soil. The first stake into each bale shall be driven toward the previously laid bale to force them together.
 - 4. Spacing between the bales shall be tightly chinked with loose straw and overlapped with an additional straw bale.
 - 5. Ends of a check dam shall be angled outward and upgradient to prevent flow around the end of the check dam before the pool reaches design level.
 - 6. After straw bales are in place the excavated soil shall be backfilled against the upslope side of the straw bales to a height of 4 inches after compacting.
 - 7. Straw bales shall be routinely inspected to determine if any repairs or replacements to the straw bales are needed. If it is determined that the straw bales need to be repaired or replaced, the work will occur immediately. Silt accumulations shall be removed before they reach 1/3 the barrier height.

3.04 WATTLES

- A. Wattles are a sediment and stormwater velocity control device. They are tubes of straw, rice straw, or coconut husk encased in ultraviolet (UV) degradable plastic netting or 100% biodegradable burlap material. Wattles help stabilize slopes by breaking up the length, and by slowing and spreading overland water flow.
- B. Wattles may be suitable along the toe, top, face, and at grade breaks of exposed and erodible slopes to shorten slope length and spread runoff as sheet flow; at the end of a downward slope where it transitions to a steeper slope; along sidewalks and curbs to prevent sediment from washing into gutters; around storm drains and drop inlets; down-slope of exposed soil areas; and around temporary material spoil and stockpiles, such as topsoil and for streambank (sensitive area) protection.
- C. Contractor shall install wattles to the following specifications:
 - 1. Installation of wattles begins by constructing a shallow trench, 2 to 4 inches deep, and shaped to accept the wattle, along the contour of the slope. All debris (rocks and clods) that would prevent close contact between the wattle and soil should be removed. The wattle is placed in the trench, and excavated material from the trench is packed tightly along the base of the wattle, on the uphill side. The wattle should be secured with 1-inch by 1-inch wooden stakes. The stakes should be placed at a 4-foot spacing and driven in perpendicular to the slope through the center of the wattle leaving less than 2 inches of stake exposed above the wattle. The terminating ends of each wattle installation should

be turned uphill a minimum of 6 inches to prevent runoff from flowing around the ends of the wattle.

2. Flat ground application. Install along sidewalks and behind curbs, fitting tightly against the concrete before backfilling, then backfill the wattle to create a trench.
3. Storm drain inlet protection. Wattles placed along the back of curb should be offset, as required to go around structures such as curb intakes that project behind the back of curb. At these locations, the wattle should be placed behind the structure (not over it) and shaped to direct water around either side of the structure to prevent ponding. At area intake locations, a shallow trench should be constructed 1 to 2 feet away from the edge of the intake. The wattle should be placed in the trench and firmly staked in place.
4. Slope application. Wattles should be installed on the contour from the bottom of the slope upward.
5. Materials. Wattles can be made from straw, rice straw, coconut husk, or other approved material. The netting consists of biodegradable burlap or ultraviolet (UV) degradable plastic netting. Straw should be Certified Weed Free Forage, by a manufacturer whose principle business is wattle manufacturing. Coir (coconut fiber) can be in bristle and mattress form, and should be obtained from freshwater cured coconut husk.
6. Application. Wattles are available in a variety of diameters ranging from 9 inches to 20 inches. The most common sizes are 9 and 12-inch wattles. The allowable spacing for these diameters shall be, as follows:

Slope	Spacing Intervals (ft)	
	9" Diameter	12 " Diameter
<4:1	20	40
2:1 to 4:1	15	30
2:1 or greater	10	20

7. For soft, loamy soils, the spacing interval should be decreased. For hard, rocky soils, the spacing interval may be increased.
8. For highly erosive soils, and for slopes 2:1 or greater, an additional row of wooden stakes should be provided on the downhill side of the wattle.
9. Maintenance. Repair or replace split, torn, unraveling or slumping wattles. If the wattle is used as a sediment capture device, or as an erosion control device to maintain sheet flows, sediment that accumulates in the wattle must be periodically removed when accumulation reaches one-half the designated sediment storage depth, usually one-half the distance between the top of the fiber roll and the adjacent ground in order to maintain effectiveness. If wattles are used for reduction of slope length, sediment removal should not be required as long as the system continues to control the grade. Additional sediment control practices are required to be used in conjunction with this type of application.

3.05 PIT/TRENCH DEWATERING

- A. Water removed from open pits and/or trenches shall have silt removed prior to leaving the immediate site of construction. Silt shall be removed by natural vegetation, a straw bale trench dewatering inlet device, settling pond, filter bag, a rock/geotextile fabric sediment trap/basin, or other appropriate sediment control measure. Water filtered through a basin shall not violate any

water quality standard and shall have efficient sediment/silt removal prior to discharging to a waterbody.

- B. Contractor shall be responsible for providing adequate number of pumps for prompt and efficient dewatering. Ends of discharge hoses shall be provided with flow dispersion and filtration devices to prevent scouring of surface soils, discharge of turbid water, and/or washout of stream banks. Discharges from dewatering activities shall not be conveyed into or upon any roadside ditch, curb and gutter, street or publicly used thoroughfare.
- C. The direct discharge of silty/muddy water to a stream is strictly prohibited.
- D. The direct discharge of silty/muddy water off of the project site is strictly prohibited.
- E. The direct discharge across areas of equipment access points and/or construction haul roads is strictly prohibited.
- F. Contractor is solely responsible for adequate maintenance of dewatering filtration and sedimentation structures to assure they are working in an efficient manner.

3.06 OTHER CONTROLS

- A. A dedicated concrete truck wash out area shall be maintained to include adequate containment to prevent runoff of concrete truck wash water. Concrete truck drivers shall be notified to use wash out area.
- B. Contractor shall follow the appropriate waste storage and disposal practices, as per applicable environmental regulatory requirements. Solid waste dumpsters/roll-offs, or other appropriate waste receptacles will be maintained and used at the site. Good housekeeping practices will preclude trash, construction wastes, and debris to be dumped or scattered on the construction site. There shall be no open burning of any waste material. No solid materials, including building materials, shall be discharged to waters of the State.
- C. No liquid waste chemicals, fuels, and/or oils are to be leaked or spilled on ground surfaces. Bulk storage of liquid chemical wastes will be provided with secondary containment with a capacity sufficient to contain the volume of the largest container within the secondary containment. All waste materials shall be stored in a manner to prevent releases and should be disposed of by a qualified waste disposal firm at an acceptable waste disposal facility. Records of the disposal of all solid, hazardous, non-hazardous, and liquid wastes are to be maintained by the Contractor. Contractor shall notify the Engineer of any spills or leaks that occur in spite of the preventive measures taken. Contractor will prepare a report of any spills or leaks in accordance with the reporting and recordkeeping measures described in the BMPs. No contaminants from fuel storage areas, hazardous waste storage and truck wash areas shall be discharged to waters of the State. These areas should not be located near a water body, if there is a water body on or near the project.
- D. Contractor shall maintain compliance with applicable State and/or local sanitary sewer, septic system, and waste disposal regulations.
- E. Used and/or waste oil generated from equipment maintenance is exempt from the hazardous waste rules, as long as it is transported offsite to be recycled/reused. Contractor shall be responsible for disposal of waste oils, fuels, and fluids at a recycling/reuse facility and shall provide written documentation of the final waste disposal method and facility location, including EPA identification number of transporter and disposal facility to the Engineer.
- F. Off-site vehicle tracking of sediments and the generation of dust must be minimized. Measures such as stone at construction access points, parking areas, and unpaved roads that carry significant amounts of traffic (e.g. more than 25 vehicles per day), providing entrance wash racks or stations

for trucks, and/or street sweeping shall be implemented where appropriate. Application of water to construction haul roads should be done, as appropriate, to control dust generation. Application of excessive levels of water that create mud should be avoided.

3.07 PERMANENT EROSION CONTROL

A. The Contractor shall incorporate permanent erosion control features into the project at the earliest practicable time as the construction progresses all in accordance with the City or State "Erosion Control Standards", and the following as necessary:

1. EROSION CONTROL FABRIC

- a. The fabrics shall act to block the force of rain and act as a mulch.
- b. The mat shall be clean and weed free using biodegradable materials that will not leave a residue.
- c. The application of the specific seed, lime, and fertilizer shall be applied immediately before laying the fabric.
- d. The fabric shall be laid according to the manufacturer's recommendations and as approved by the City.

2. RIPRAP

- a. Riprap shall be placed where indicated on the approved plans and in accordance with the State of Arkansas Highway Standards.
- b. The type of riprap required shall be indicated on the Drawings and as directed and approved by the City.
- c. Non-woven filter fabric shall be placed beneath the riprap as shown on the Drawings. Filter fabric shall be a minimum of 12 oz/sy by weight.

3. SEED/SOD

- a. Seed mixtures and mulched seeding shall be placed as early as practicable to keep the area of bare soil exposed at any one time by construction operations to a minimum.
- b. Sod shall be placed as shown on the approved Drawings and as directed by the City.
- c. Seed and sod shall be placed according to Section 6100.

4. GABIONS (STONE FILLED)

- a. Gabion materials shall be non-corrosive, high strength polyethylene, or galvanized steel.
- b. Stone fill material shall be placed in the gabion by hand. The stone shall be hard durable rock not less than three (3) inches.
- c. The gabion shall be constructed, installed, and filled as recommended by the manufacturer and as directed by the City.

3.08 APPROVED ALTERNATIVES

- A. The Contractor may use alternate permanent erosion control protection methods only with written authorization from the City.

END OF SECTION 2100

SECTION 2200
SITE PREPARATION

PART 1 - GENERAL

1.01 WORK INCLUDED

- A. Excavation, grading, cutting and removal of trees, shrubs and underbrush, and the removal of any debris existing above natural ground surface and within the cleared area necessary to permit the construction of the improvements.

1.02 RELATED WORK

- A. Section 3000 – Sewer Pipe, Fittings, and Materials
- B. Section 3100 – Installation of Sewer Pipe, Fittings, and Materials
- C. Section 3200 – Installation of Sewer Service Lines
- D. Section 3300 – Manholes
- E. Section 3400 – Steel Encasement Pipe
- F. Section 4000 – Water Pipe, Fittings, and Materials
- G. Section 4100 – Installation of Water Pipe, Fittings, and Materials

1.03 PROTECTION

- A. In all cases the Contractor is responsible for protecting public and private property and protecting any person or persons who might be injured as a result of the Contractor's work.
- B. All utilities shown on the drawings may not represent the exact location however, the Contractor is responsible for verifying these locations and contacting the Arkansas One Call System before excavating.

PART 2 - MATERIALS

- A. Not used

PART 3 - EXECUTION

3.01 GENERAL

- A. The Contractor will be required to submit a plan to build access roads/trails for approval by the Engineer.
- B. It shall be the responsibility of each bidder to examine the site carefully and make his own calculations as to costs to be incurred by reason of the requirements of this section.
- C. Trees, shrubs, underbrush and debris removed from the improvement right of way shall be disposed of by the Contractor in a manner approved by the City.

3.02 SITE PREPARATION

- A. Clear areas necessary for performance of the work and confine operations to that area provided through easements, licenses, agreements and rights-of-way. Entrance upon any lands outside of that area provided by easements, licenses, agreements or public rights-of-way, shall be at the Contractor's sole liability
- B. Do not occupy any portion of the project site prior to the date established in the Notice to Proceed without prior approval of the Owner.
- C. Contractor shall be aware of certain requirements by individual property owners as stipulated in easement documents pertaining to the project.
- D. Remove, relocate, reconstruct or work around natural obstructions, existing facilities and improvements encountered during site preparation as herein specified. Take care while performing site preparation work adjacent to facilities intended to remain in place. Promptly repair damage to existing facilities. Dispose of waste materials in a satisfactory manner off the work site.
- E. Protect, move, or brace public and private utilities as required by the affected utility.
- F. Maintain mailboxes in the manner that the Postal Service requires to prevent interruption of mail delivery.
- G. Site preparation includes the removal of trees, shrubs, brush, crops, and other vegetation within the limits of the easements (right-of-way), or as may be provided for in licenses, permits and agreements. All efforts shall be made to retain existing landscaping. In the event that trees, shrubbery, and hedges cannot be saved, then prior approval of the Owner and the Owner's Representative must be obtained before the existing landscaping is removed.
 - 1. Trees
 - a. All trees shall be saved unless removal is approved by the City and the Inspector. Trim trees in accordance with the City's instructions.
 - 2. Shrubbery
 - a. Shrubbery shall be saved unless removal is approved by the City and the Owner's Representative. Make reasonable efforts to save all shrubbery by trimming, in accordance with acceptable pruning practices, and treating wound surfaces with a commercial pruning compound.
 - 3. Small Plants and Flowers
 - a. At least two weeks prior to the start of construction, notify property owners of the proposed starting date so that the property owners can remove any small plants or flowers.
 - 4. Protection of Existing Facilities
 - a. The Contractor shall notify all property owners in the immediate vicinity of the construction area that may be affected by the construction activities a minimum of 24-hours before starting work in that area. The notification shall include a description of the work, work hours, and a 24-hour contact name and number for the contractor.

- b. Fences interfering with construction, and located within public rights-of-way or as may be allowed for in permits or agreements, may be removed only if the opening is provided with a temporary gate which will be maintained in a closed position except to permit passage of equipment and vehicles, unless otherwise herein specified. Fences within temporary construction easements may be removed provided that temporary fencing is installed in such a manner as to serve the purpose of the fencing removed.
- c. Fencing removed shall be restored to the condition existing prior to construction unless otherwise specified. The Contractor is solely liable for the straying of any animals protected or corralled or other damage caused by any fence so removed.
- d. Driveways and driveway approaches removed or damaged during construction shall be restored to the original condition or better condition prior to construction.
- e. Make every reasonable effort to protect private sewer facilities. Private sewer facilities may not be shown on the Plans.
- f. Preserve property corners, pins and markers. In the event any property corners, pins, or markers are removed by the Contractor, such property points shall be replaced at the Contractor's expense and shall be re-set by competent surveyors properly licensed to do such work. In the event such points are section corners or Federal land corners, they shall be referenced and filed with the appropriate authority.
- g. Where existing utilities and service lines are encountered, notify the owner thereof at least 48 hours (not including weekends and/or holidays) in advance of performing any work in the vicinity.
- h. Excavate, install pipeline and backfill in the vicinity of such utilities in the manner required by the respective owner and, if requested, under his direct supervision. The Contractor shall be responsible for damages to a public or private utility that may occur as the result of the construction.
- i. Protect, move, or brace public and private utilities as required by the affected utility.
- j. Make a reasonable effort to ascertain the existence of obstructions and locate obstructions by digging in advance of machine excavation where definite information is not available as to their exact location. Where such facilities are unexpectedly encountered and damaged, notify responsible officials and other affected parties and arrange for the prompt repair and restoration of service.

END OF SECTION 2200

SECTION 2300**EXCAVATION, BACKFILLING, AND COMPACTING****PART 1 - GENERAL****1.01 WORK INCLUDED**

- A. Excavation, backfilling, and compaction for water lines, sewer lines, appurtenances, and incidental construction.

1.02 RELATED WORK

- A. Section 3000 – Sewer Pipe, Fittings, and Materials
- B. Section 3100 – Installation of Sewer Pipe, Fittings, and Materials
- C. Section 3200 – Installation of Sewer Service Lines
- D. Section 3300 – Manholes
- E. Section 3400 – Steel Encasement Pipe
- F. Section 4000 – Water Pipe, Fittings, and Materials
- G. Section 4100 – Installation of Water Pipe, Fittings, and Materials
- H. Section 6000 - Pavement Repair
- I. Section 6100 - Lawns & Grasses

1.03 QUALITY ASSURANCE

- A. If requested by the City, one moisture/density relationship test (AASHTO T-99 with Note 7, or AASHTO T-180 with Note 8) shall be taken at the beginning of the project, and one additional moisture/density relationship test shall be taken for every 5,000 cubic yards of imported material. ASTM testing methods for moisture/density relationships may not be used for embankment and subgrade materials.
- B. Determine the field density of backfill in accordance with AASHTO Designation T-147.
- C. A minimum of one density test per 500 lineal feet of pipe or portion thereof when the pipe is located in the street or under the curb and gutter.

1.04 REFERENCES

- A. Not Used.

1.05 PROTECTION

- A. The Work included in this Project may require excavation and related activities in close proximity to existing buried and aerial utility lines and facilities, such as water lines, sewer lines, storm drains, natural gas lines, electrical power lines, telephone cables, and TV cables. Where their presence is known, the approximate location of such utilities is shown on the Drawings, but all such utilities and individual service lines are not shown. The Contractor shall be aware of the potential for such utility lines to conflict with intended construction efforts, and the Contractor

shall use appropriate precautionary measures to locate and protect such utility lines and services so as to avoid damage and interruptions to service.

- B. The Contractor shall contact the owners of the various existing utilities lines and services as may be affected by the construction and solicit their assistance in identifying, locating, marking, and protecting these facilities prior to the beginning of any excavation or other work which might endanger the existing utilities. If such utilities are damaged or impaired because of the Contractor's actions or omissions, the Contractor shall be responsible for the cost of repairs or replacements of the affected or damaged utility or service line.
- C. The Contractor shall comply with the Arkansas One-Call System and shall alert potentially conflicting utility systems accordingly.
- D. In all cases, the Contractor is responsible for protecting public and private property; and, protecting any person or persons who might be injured as a result of the Contractor's work.

1.06 DUST CONTROL

- A. The Contractor shall be responsible for maintaining the site and adjoining paved surfaces in a dust free condition. Fugitive dust control is the sole responsibility of the Contractor.

1.07 SEDIMENT CONTROL

- A. The Contractor shall be responsible for all sediment control in accordance with Section 2100 – Erosion and Sediment Control.

PART 2 - PRODUCTS

2.01 EMBEDMENT MATERIALS - GENERAL

- A. Embedment materials are restricted to materials as described below.
- B. Gravel material for select backfill across streets, roads, driveways, and for placement of "gravel" surfaced areas, shall be Class 7 material conforming to the Standard Specifications of the Arkansas Highway & Transportation Department, latest edition.

2.02 CLASS I EMBEDMENT MATERIAL

- A. Class I embedment material shall be in accordance with ASTM D 2487, latest edition and shall conform to class 1A embedment materials in accordance with ASTM D 2321, latest edition. Material shall meet the grading requirements of ASTM C 33, gradation 67, commonly referred to as ASTM #67 (3/4" concrete aggregate or 5/8" aggregate) or ASTM C 33, gradation 7, commonly referred to as ASTM #7 (1/2" aggregate). Maximum aggregate size shall be 3/4 inch. This includes materials such as crushed stone or rock.

2.03 GRIT EMBEDMENT MATERIAL

- A. Grit embedment material is permitted for the installation of water lines. It is not permitted for the installation of sewer lines. Grit shall be the by-product of rock crushing, generally consisting of 1/4" and smaller limestone material.

2.04 SELECT NATIVE BACKFILL MATERIAL

- A. Select native material shall be good earth, sand, or gravel that is free from large rocks or hard lumpy materials. Never use materials of perishable, frozen, spongy or otherwise unsuitable nature as select material.

2.05 FLOWABLE FILL MATERIAL

- A. Flowable fill material for select backfill across streets, roads, and driveways shall be Flowable Select Material conforming to the Standard Specifications of the Arkansas Highway & Transportation Department, latest edition.

2.06 RIPRAP

- A. Riprap material for bank stabilization and erosion control shall conform to the Standard Specifications of the Arkansas Highway & Transportation Department, latest edition. Riprap shall be designed by an Engineer for the application, including area, size, and depth of placement.

PART 3 - EXECUTION

3.01 EXCAVATION - GENERAL

- A. All excavation shall be carried accurately to the line and grade shown on the Drawings and as established by the Engineer.
- B. When excavation is necessary to be carried below or beyond that which is required, fill the over-excavated space with compacted Class I material, or with concrete as approved by the Engineer.
- C. The Contractor shall use a trench box or provide and install shoring where necessary to protect the labor, the work, or adjacent property. Shoring shall be maintained in place until the backfill has proceeded to a point where it can be safely removed.
- D. Dewater all excavations before any construction is undertaken in accordance with Section 2100 of these specifications.
- E. Install pipe only in dry trenches. Place concrete upon dry, firm foundation material only.

3.02 DISPOSAL OF EXCAVATED MATERIALS

- A. The Contractor shall be responsible for disposal of excess material, or disposal of excavated material unsuitable for backfilling.
- B. Disposal of excess material shall only be allowed on private property with written permission of the owner of the property. A copy of the written permission must be forwarded to the Engineer along with any permits as may be required by the governing authority, city or county. Grading permits are required for any disposal within the City of Bryant city limits.

3.03 EXPLOSIVES

- A. Notify the Engineer in advance if the use of explosives is necessary for the efficient execution of the work.
- B. All work pertaining to the use of explosives shall be performed by qualified personnel.
- C. The Contractor shall obtain all the necessary permits from all governmental bodies. Copies of permits must be submitted to the Engineer and the Contractor shall keep a copy of all permits on the job site at all times.
- D. Follow all governing OSHA safety regulations.

- E. Exercise every precaution to prevent damage to adjoining improvements or property.
- F. Always use a blasting shield or mat.
- G. Any damage to private property resulting from the use of explosives is the liability of the Contractor.

3.04 TRENCH DEWATERING

- A. Dewater all trenches, in accordance with Section 2100, to the extent that water or sewer pipe can be placed on a dry and firm trench bottom. Never place pipe in a wet or unstable trench. The allowable dewatering methods are:
 - 1. Well pointing; and,
 - 2. Over Excavation and Sump Pumping. Submit for approval other trench dewatering procedures.
- B. Well Pointing Procedure
 - 1. Install well points where required to keep the excavation dry and the subgrade stable.
 - 2. Install well points when the excavation is within two (2) feet of the water table.
 - 3. Provide sufficient pumping equipment, in good working order and available at all times, to remove any water that accumulates in excavations so a stable subgrade is obtained.
 - 4. Keep all dewatering equipment in continuous operation until backfill is completed.
- C. Pump, pipe, and drain all water resulting from dewatering operations into a properly designed dewatering structure or device in accordance with Section 2100. Prevent flooding of streets or private property.
- D. Soil that cannot be properly dewatered: excavate and install 2" – 3" rock to provide a firm trench bottom.
- E. Divert surface runoff water away from the excavation. Where the excavation crosses natural drainage channels, care should be taken to prevent unnecessary damage or delays. Route diverted surface water into existing drainage structures, such as storm sewers, ditches, or streams. Prevent flooding of streets or private property.
- F. Discharge of trench water or surface runoff into a sanitary sewer is a violation of City of Bryant Ordinance and violators will be prosecuted as prescribed by law.

3.05 SHEETING AND SHORING

- A. Provide sheeting and shoring of trenches to:
 - 1. Protect the safety of workers;
 - 2. Provide suitable means for constructing the sewer line;
 - 3. To maintain the trench free from slides or cave-ins;

- 4. And, to protect public or private property, including existing utilities, buildings, streets, or other structures that are close to the trench.
- B. Follow all governing OSHA safety regulations.
- C. Keep shoring in place until the backfill has proceeded to a point where it can safely be removed.

3.06 EXCAVATION –TRENCHES

- A. Trench For Water or Sewer Line - During excavation, all pipe to be replaced shall be removed and disposed of offsite at a suitable landfill. Trench excavation for water or sewer lines shall be kept within the maximum width limits as shown on the Drawings. The specified maximum trench width from the bottom of the trench to 24-inches above the outside top of the pipe shall not be exceeded unless specifically authorized by the Engineer.
- B. Trench For Water or Sewer Line in Paved Area – Prior to excavation in paved areas, the Contractor shall saw-cut (or other acceptable method approved by the Engineer) the existing pavement to minimize the destruction of the existing pavement outside the limits of the trench. The maximum trench width for the installation of water or sewer lines, up to 12-inches in diameter, in paved areas shall not exceed 36-inches without written approval from Engineer. The pavement shall be repaired in accordance with Section 6000 – Pavement Repair. Contractor is responsible for damage to paved areas by construction equipment outside the limits of trench excavation.
- C. Keep the trench widths within the limits specified below. This requirement is to avoid superimposed loading in excess of the designed and specified pipe strength; and to provide sufficient room for proper installation and bedding of water and sewer lines.

Inside Pipe Diameter (inches)	Maximum Width of Trench From Top of Pip to 2' Above Top of Pipe
6, 8, 10	2' – 6"
12, 14, 15, 16	3' – 0"
18, 21	3' – 6"
24, 30	4' – 0"
36	4' – 6"
42	5' – 0"

- D. If necessary to prevent sliding and caving, cut the trench banks back on a slope above an elevation two (2) feet above the outside top of the pipe to reduce the earth load on the trench sides. Never exceed the specified maximum width until 2 ft. above the outside top of the pipe. See Section 2000 – Trench Safety.
- E. Do not advance trench excavation more than three hundred (300) feet ahead of the completed pipe work and backfill.

3.07 OVER EXCAVATION

- A. Over excavate below the required subgrade only under the conditions as listed below.

1. The soil at the bottom of the trench is mucky or in such condition that it cannot be properly shaped and graded.
 2. The subgrade material is too soft to properly support the pipe.
- B. After over excavating, provide and install a fill consisting of 2" – 3" rock thoroughly tamped into place in a maximum of eight (8) inch lifts up to an elevation sufficient to prepare the subgrade for the particular bedding class required.

3.08 BEDDING AND BACKFILLING - GENERAL

- A. Install all sewer pipe using Class I embedment materials only. Refer to Standard Detail Drawings.
- B. Install all water pipe using Class I embedment materials or grit embedment materials. Refer to Standard Detail Drawings.
- C. It is essential that the complete backfill be done in such a manner to minimize voids in the backfill.
- D. Backfilling includes refilling and consolidating the fill in the excavation up to the surrounding ground surface or road grade.
- E. Use select native materials for backfilling in unpaved areas.
- F. Where trenches are to be located beneath existing or proposed streets, drives, and parking areas, all backfilling procedures shall be in accordance with the Standard Detail Drawings.
- G. Use mechanical compaction devices manufactured for that purpose to compact backfill materials in trenches.
- H. Pipe marking tape shall be provided in all trenches for water or sewer line construction. Installation shall be per manufacturer's recommendations and shall be as close as practical to finished grade while maintaining a required minimum of 18 inches between the marking tape and the top of any pipe line.

3.09 BEDDING AND BACKFILLING PIPE

- A. Bed pipe as described below and in accordance with the standard trench details shown in Standard Detail Drawings. The intent of the bedding is to create a uniform support which will protect the pipe from localized stress points and to provide for a well graded trench bottom.
- B. Provide a minimum cover of thirty-six (36) inches over the top of pipe.
- C. Extend the trench excavation to a minimum depth of six (6) inches below the bottom of the pipe.
- D. Install bedding materials in no greater than eight (8) inch compacted lifts. Install bedding from six (6) inches below the pipe to six (6) inches above the pipe. Shovel slice bedding beneath the pipe haunches. Tracer wire shall be installed six (6) inches above the top of pipe.
- E. Compact all bedding material to a minimum density of 80% standard proctor as outlined in AASHTO T-99.
- F. The maximum depth of bury for PVC pipe is sixteen (16) feet. Any depths greater than sixteen (16) feet require ductile iron pipe, unless approved by the City of Bryant.

- G. Install pipe in accordance with Section 3100 and Section 4100.
- H. Backfill and compact the excavation.

3.10 EXCAVATION, BACKFILLING AND COMPACTION FOR MISCELLANEOUS STRUCTURES

- A. Excavate a sufficient distance from walls and footings to allow for forms and for proper inspection.
- B. Leave at least (12) inches between the outer surface of miscellaneous structures and the excavation or shoring.

3.11 RIPRAP

- A. The slope shall be properly prepared to receive riprap and shall include all necessary excavation and backfill and the construction of a toe trench if required.
- B. Place riprap as shown on the Drawings or as directed by the Engineer.

END OF SECTION 2300

SECTION 3000**SEWER PIPE, FITTINGS, AND MATERIALS****PART 1 - GENERAL****1.01 WORK INCLUDED**

- A. This section covers the manufacture, transportation, and storage of pipe, pipe joints, and fittings for sanitary sewer pipelines and service lines.
- B. Use only pipe, fittings, and adapters approved by the City of Bryant.
- C. Use bends, tees, plugs, wyes, or other approved fittings constructed from the same material as the pipe in which they are installed. Use only standard, approved fittings.

1.02 RELATED WORK

- A. Section 3100 - Sanitary Sewer Pipelines
- B. Section 3200 - Sanitary Sewer Service Lines
- C. Section 3300 - Manholes
- D. Section 5200 - Inspection and Testing of Sanitary Sewer Pipelines, Manholes, and Service Lines

1.03 SUBMITTALS

- A. Use of materials other than those specifically listed below is prohibited.
- B. Submit the manufacturer's certificate that the pipe meets with these Specification requirements including material testing requirements.

1.04 REFERENCES

- A. Not Used.

PART 2 - PRODUCTS**2.01 PROHIBITED PIPE MATERIALS**

- A. The following materials are specifically forbidden for use either in city sewers or service lines:
 - 1. Asphalt impregnated fiber tube pipe.
 - 2. Clay pipe.
 - 3. Concrete pipe.
 - 4. Open profile PVC pipe as defined in ASTM F794.
 - 5. "No Hub" cast iron soil pipe or other non bell and spigot pipe.

2.02 SERVICE LINES AND FITTINGS

- A. Service lines are four (4) inches in diameter or larger.

- B. Furnish the following:
 - 1. Polyvinyl chloride (PVC) pipe for service lines shall be SCH 40, glue joints, and shall be completely bedded as required for larger PVC pipe or SDR 26 PVC meeting the requirements of section 2.04 of these specifications.
- C. Fittings for service lines shall be:
 - 1. SCH 40 PVC with glue joints or SDR 26 PVC meeting the requirements of section 2.04 of these specifications.

2.03 CLEANOUTS

- A. Cleanouts shall be Two-Way Memphis Code, SCH 40 PVC. The riser pipe shall be topped off with a screw type plug.
- B. Cleanouts installed in asphalt or concrete shall be protected by a cast iron short bodied valve box, Model 70 as manufactured by East Jordan Iron Works.

2.04 POLYVINYL CHLORIDE (PVC) GRAVITY SEWER PIPE (Solid Wall)

- A. Pipe fifteen (15) inches in diameter and less: conform to ASTM D 3034. Maximum standard dimension ratio (SDR) shall be twenty six (SDR 26).
- B. Pipe greater than (15) inches in diameter: conform to ASTM F 679 (PS 115).
- C. Joint connections: push on, elastomeric gasket type conforming to ASTM D 3212 and ASTM F477.
- D. Marking: The date of manufacture, class of pipe, specification designation, size of pipe, name or trademark of manufacturer, and identification of plant/location shall be legibly marked on the outside of each pipe section in accordance with the ASTM D-3034.

2.05 POLYETHYLENE ENCASEMENT (PIPE WRAP)

- A. Polyethylene encasement shall be in conformance to ANSI/AWWA C105, latest revision. The virgin linear low-density polyethylene film shall have a minimum normal thickness of .008 inches (8 mils), and shall be provided in either flat tube or sheet form.
- B. The color shall be black with nominal 2% carbon black UV inhibitor and printed per the AWWA C105 standard.
- C. Tape for field taping of polywrapped pipe, fittings, etc. or field repair of missing polyethylene encasement material shall be Polyken #900, Scotchrap #50 or equal, at least 2-inches wide, and installed as per the Polyethylene Encasement Installation Guide published by DIPRA. Duct Tape is not permitted.
- D. All buried iron pipe and fittings shall be poly wrapped.

2.06 INTERIOR AND EXTERIOR LINING FOR DUCTILE IRON PIPE AND FITTINGS

- A. All gravity and force main pipe and fittings located at a pump station site shall be furnished with a 40 mil nominal dry film thickness protective lining on the interior consisting of an amine cured novalac epoxy containing at least 20% by volume of ceramic quartz pigment. The lining material

shall be Protecto 401 Ceramic Epoxy or approved equal. All other ductile iron pipe and fittings shall have interior cement mortar lining in accordance with AWWA C104.

- B. All cut ends shall be immediately repaired with a field epoxy touch-up kit.
- C. All buried ductile iron pipe and fittings shall be furnished with standard bitumastic coating on the exterior per AWWA standard.
- D. Exposed ductile iron pipe and fittings shall be coated on the exterior with Tnemec 140-1211 primer, Series 66 HB Epoxoline at 4 to 6 mils, followed by Series 74 Endura Shield at 2 to 4 mils, or equal coating

2.07 DUCTILE IRON PIPE FOR GRAVITY MAINS

- A. Ductile Iron Pipe shall conform to the requirements of "Ductile-Iron Pipe, Centrifugally Cast" AWWA Standard C151/A21.51, latest revision.
- B. Minimum Pressure Class shall be as follows:
 - 1. 18-inch and smaller 350 psi
 - 2. 24-inch 250 psi
 - 3. 30-inch and greater 200 psi
- C. All gravity ductile iron pipe located at a pump station site shall be furnished with a 40 mil nominal dry film thickness protective lining on the interior consisting of an amine cured novalac epoxy containing at least 20% by volume of ceramic quartz pigment. The lining material shall be Protecto 401 Ceramic Epoxy or approved equal. All cut ends shall be immediately repaired with a field epoxy touch-up kit. All other gravity ductile iron pipe and fittings shall have interior cement mortar lining in accordance with AWWA C104.
- D. Joint connections, pipe and fittings:
 - 1. Push on and mechanical rubber gasket joints: ANSI/AWWA C111/A21.11.
 - 2. Flanged: ANSI/AWWA C115/A21.15, ANSI B16.1.
 - 3. Grooved and shouldered ANSI/AWWA C606.
- E. Weights and Marking: Weights of pipe and fittings shall conform strictly to the requirements of ANSI Specifications. The class designations for the various classes of pipe and fittings shall be cast onto fittings in raised numerals, and cast or stamped on the outside of each joint of pipe. Weights shall be plainly and conspicuously painted in white on the outside of each joint of pipe and each fitting after the exterior coating has hardened.
- F. Corrosion Control
 - 1. Polyethylene wrap in tube or sheet form conforming to the requirements of ANSI/AWWA C105/A21.5. The pipe shall be double wrapped.
 - 2. All buried ductile iron pipe and fittings shall be furnished with standard bitumastic coating on the exterior per AWWA standard.

3. Exposed ductile iron pipe and fittings shall be coated on the exterior with Tnemec 140-1211 primer, Series 66 HB Epoxoline at 4 to 6 mils, followed by Series 74 Endura Shield at 2 to 4 mils, or approved equal.

2.08 DUCTILE IRON FITTINGS

- E. All ductile iron fittings shall conform to the requirements of ANSI/AWWA C153/A21.53, latest revision, for Ductile Iron Compact Fittings.
- F. All ductile iron fittings located within a pump station site shall have a interior ceramic epoxy coating suitable for sewer service, Protecto 401, or equal. All other ductile iron fittings shall have interior cement mortar lining in accordance with AWWA C104.
- G. Buried ductile iron fittings shall be furnished with standard bitumastic coating on the exterior per AWWA standard.
- H. Exposed ductile iron pipe fittings shall be coated on the exterior with Tnemec 140-1211 primer, Series 66 HB Epoxoline at 4 to 6 mils, followed by Series 74 Endura Shield at 2 to 4 mils, or equal coating.

2.09 CENTRIFUGALLY CAST FIBERGLASS GRAVITY SEWER PIPE

- A. Pipe shall conform to all requirements of ASTM 3262 for fiberglass pipe.
- B. Pipe stiffness shall meet or exceed manufacturer's recommendations. Minimum pipe stiffness shall be 46 psi.
- C. Manufactured by Hobas USA, Inc.

2.10 REINFORCED FLEXIBLE RUBBER COUPLINGS

- A. Materials: Chemical resistant rubber. Flexible rubber coupling shall be Fernco or equal.
- B. Flexible rubber coupling shall be reinforced with a stainless steel shear ring.
- C. Clamping bands: two (2) each stainless steel bands.
- D. Dimensions: Inside diameter to fit the outside diameter of the different pipe materials being connected: take care that proper alignment is maintained and the spacing between pipes does not exceed 1/2 inch as shown in the Standard Detail Drawings.

2.11 SERVICE SADDLES

- A. A composite saddle using a Virgin SBR compound gasket (ASTM D-2000 3 BA715) and a ductile iron saddle casting (ASTM A 536 Grade 65-44-12) as shown in the Standard Details.
- B. All saddles shall be approved by the City of Bryant prior to installation.

2.12 SERVICE WYES

- A. The wye material and joint type must match that of the mainline pipe.
- B. Wyes shall terminate in a bell suitable for connection of a 4 inch SCH 40 PVC service line pipe as specified herein.

2.13 MECHANICAL JOINT RETAINER GLANDS

- A. Restraint devices for mechanical joint fittings and appurtenances for nominal pipe sizes 3-inch through 48-inch shall consist of multiple gripping wedges incorporated into a follower gland meeting the applicable requirements of ANSI/AWWA C110/A21.10.
- B. Mechanical joint retainer glands shall be made from ductile iron and shall be designed for a working pressure of at least 350-psi for 3-inch through 16-inch ductile iron pipe, at least 250-psi for 18-inch through 48-inch ductile iron pipe. Mechanical joint retainer glands for Series 1100 by EBBA Iron, Inc. for 3-inch through 48-inch ductile iron pipe, Series 2000 PV for 3-inch through 36-inch PVC pipe, and Series 2200 for 42-inch through 48-inch PVC pipe.
- C. Retainer glands shall have an approved coating system for corrosion resistance equivalent to MEGA-BOND® and manufacturing traceability.
- D. Retainer glands shall be furnished on all mechanical joint fittings.

2.14 PIPE RESTRAINTS

- A. Bell restraints for AWWA C900 PVC sizes 4-inch through 12-inch shall be Series 1900 Restraint Harness, as manufactured by EBAA Iron, Inc. Devices shall have an approved coating system for corrosion resistance equivalent to MEGA-BOND® and manufacturing traceability.
- B. Bell restraints for AWWA C905 PVC sizes 14-inch through 36-inch shall be Series 2800 as manufactured by EBAA Iron, Inc. Devices shall have an approved coating system for corrosion resistance equivalent to MEGA-BOND® and manufacturing traceability.
- C. Bell restraints for SDR21 PVC sizes 2-inch through 12-inch shall be provided as required and shall be Series 6500 by EBBA Iron, Inc. Devices shall have an approved coating system for corrosion resistance equivalent to MEGA-BOND® and manufacturing traceability.
- D. Bell restraints for Ductile Iron Pipe sizes 4-inch through 48-inch shall be Series 1700 Restraint Harness, as manufactured by EBAA Iron, Inc. Devices shall have an approved coating system for corrosion resistance equivalent to MEGA-BOND® and manufacturing traceability.
- E. When all-thread attachments are required, eye-bolt style attachments are not acceptable. Romac “Ductile Lug” style attachments or approved equal shall be used. All-threads shall be made of 316 stainless steel.

2.15 BOLTS

- A. All bolts for valves, fittings, and restraints shall be 316 stainless steel. Anti-seize lubricant shall be used when assembling all stainless steel hardware to reduce galling.

2.16 FORCE MAIN MATERIALS

- A. Each material acceptable for force main construction is described below.

2.17 POLYVINYL CHLORIDE (PVC) PIPE FOR FORCE MAINS

- A. PVC pipe less than 4 inches in size shall be manufactured in accordance with ASTM D-2241 and shall be minimum SDR 21. Pressure class of pipe shall be increased as appropriate for the design conditions and shall be as shown on the Drawings.
- B. PVC pipe 4 inches through 12 inches in size shall be manufactured in accordance with ASTM D-2241 minimum SDR 21 (200 psi) or AWWA C900, latest revision, and shall be minimum DR 25

(165 psi). Pressure class of pipe shall be increased as appropriate for the design conditions and shall be as shown on the Drawings.

- C. PVC pipe greater than 12 inches in size shall be manufactured in accordance with AWWA C905 and shall be minimum DR 25 (165 psi). Pressure class of pipe shall be increased as appropriate for the design conditions and shall be as shown on the Drawings.
- D. PVC pipe, couplings, and fabricated fittings shall be made from virgin PVC resin that has been compounded to provide physical and chemical properties that equal or exceed cell class 12454 as defined in ASTM D1784, latest revision. Clean, reworked material generated from the manufacturer's own production shall be acceptable as long as the pipe produced meets all the requirements of the Specifications.
- E. Joints for PVC pipe shall conform to ASTM Specification D-3139, latest revision. Rubber gaskets shall comply with ASTM F-477, latest revision.
- F. Nominal laying length shall be 20 feet. Minimum length of a cut section of pipe shall be 5 feet.
- G. Pipe shall be green in color.
- H. Marking on pipe and shall include the following and shall be applied at intervals of not more than 5 feet.
 - 1. Nominal size in inches and OD base (for example, 4 CI).
 - 2. PVC.
 - 3. Dimension ratio (for example, DR 14).
 - 4. AWWA pressure class (for example, PC 305).
 - 5. Test pressure for hydrotested pipe (for example, T330) or if not tested, "NOT HYDROSTATIC PROOF TESTED."
 - 6. AWWA designation number for this standard (ANSI/AWWA C900 or ASTM D-2241).
 - 7. Manufacturer's name or trademark and production run record or lot code.
 - 8. Seal (mark) of the testing agency verifying the suitability of the pipe material for potable-water service.

2.18 DUCTILE IRON PIPE FOR FORCE MAINS

- A. Ductile Iron Pipe shall conform to the requirements of "Ductile-Iron Pipe, Centrifugally Cast" AWWA Standard C151/A21.51, latest revision.
- B. Ductile iron pipe shall be designed in accordance with the requirements of "Thickness Design of Ductile-Iron Pipe", ANSI/AWWA C150/A21.50, latest revision. Minimum pressure class shall be 250 psi.
- C. Joint connections, pipe and fittings (latest revision):
 - 1. Push on and mechanical rubber gasket joints: ANSI/AWWA C111/A21.11.
 - 2. Flanged: ANSI/AWWA C115/A21.15, ANSI B16.1.

3. Grooved and shouldered ANSI/AWWA C606.
- D. Nominal laying length shall be 20 feet. Minimum length of a cut section of pipe shall be 5 feet.
- E. Weights and Marking: Weights of pipe and fittings shall conform strictly to the requirements of ANSI Specifications. The weight, class or nominal thickness, and casting period shall be shown on each pipe. The manufacturer's mark, country where cast, year in which the pipe was produced, and the letters "DI" or "DUCTILE" shall be cast or metal stamped on the pipe, and letters and numerals on pipe sizes 14 in. (356 mm) and larger shall be not less than 1/2 in. (13 mm) in height.
- F. Corrosion Control
1. Ductile iron pipe and fittings shall be furnished with standard bitumastic coating on the exterior per AWWA standard. Exposed ductile iron pipe and fittings shall be coated on the exterior with Tnemec 140-1211 primer, Series 66 HB Epoxoline at 4 to 6 mils, followed by Series 74 Endura Shield at 2 to 4 mils, or approved equal.
 2. All gravity and force main ductile iron pipe and fittings located within a pump station site shall be furnished with a 40 mil nominal dry film thickness protective lining on the interior consisting of an amine cured novalac epoxy containing at least 20% by volume of ceramic quartz pigment. The lining material shall be Protecto 401 Ceramic Epoxy or approved equal. All cut ends shall be immediately repaired with a field epoxy touch-up kit. All other ductile iron fittings shall have interior cement mortar lining in accordance with AWWA C104.
 3. Cut sections of pipe shall be immediately repaired with a field kit to restore the ceramic epoxy coating system.
 4. Polyethylene wrap in tube or sheet form conforming to the requirements of ANSI/AWWA C105/A21.5, latest revision. The pipe shall be wrapped.

2.19 VALVES FOR FORCE MAINS

- A. Gate valves shall be the same as water valves.
- B. Full port (100% area) plug valves shall be AWWA C517, latest revision shall be manufactured by Val-Matic or Dezurik PEC.
- C. Valves shall be installed along the length of the force main, not to exceed 1000' unless a variance is approved by the City for long force mains. All lids shall have the word "SEWER" and a concrete collar with a minimum of 18 inches square or round dimension as appropriate.

2.20 AIR / VACUUM RELIEF VALVES

- A. Sanitary sewer force mains shall be designed to avoid the need for air or vacuum release lines. If possible, force mains shall be designed without high points and with the top of the force main below the hydraulic grade line at the minimum pumping rate so that relief valves will not be needed.
- B. If high points in the force main cannot be eliminated, a stainless steel or composite A.R.I. (model #D-025 NPT) sewage air release valve or approved equal shall be installed at each significant high point where air could become trapped. The air release valve shall be installed in a manhole structure in accordance with the requirements of Section 3300-Manholes, and provisions shall be required for draining the structure.

2.21 TRACER WIRE

- A. Tracer wire shall be 12-gauge solid coated copper for underground burial.
- B. Jacket color shall be GREEN, and made of High Density Polyethylene (HDPE) or High Molecular Weight Polyethylene (HMWPE) designed for direct burial.
- C. Connectors shall be used for all splices or repairs. Connectors shall be moisture displacement style as manufactured by 3M DBR, or equal.
- D. A locate or conductivity test shall be performed prior to signing off on the project.
- E. A tracer wire test station shall be installed every 1,000 feet, in the vicinity of the discharge manhole, and at fittings that cause a change in direction where the tracer wire can be brought to grade for a point of connection to aid in tracing the force main. All lids shall have the word "SEWER" and a concrete collar with a minimum of 18 inches square or round dimension as appropriate. Tracer wire test station shall be in accordance with the standard sewer details.

2.22 MARKING TAPE

- A. Non-metallic sanitary sewer marking tape shall be warning tape as manufactured by Rhino Marking and Protection Systems, Terra Tape Extra Stretch, Harris Industries, Inc., or approved equal.
- B. Tape shall have a minimum thickness of 4 mils and manufactured with heavy metal-free polyethylene tape that is impervious to all known alkalis, acids, chemical reagents, and solvents found in soil. The minimum overall width of the tape shall not be less than 3-inches. Standard rolls shall be 1000' length.
- C. The tape shall be color coded Safety Green and imprinted with the following message: Caution – Buried Sewer Line Below

2.23 SEWER LINE MARKERS

- A. Sewer line markers shall be fiberglass reinforced composite, 3.75-inches wide and green in color.
- B. Sewer line markers shall be as manufactured by Rhino Marking and Protection Systems, Carsonite International, or approved equal. All markers shall be installed according to the manufacturer's recommendations.
- C. Fiberglass sewer line markers shall have decals for visible identification of buried sewage force main day or night on both sides of the marker.
- D. Sewer line pipeline markers shall be installed every 500 feet and beside all manholes that are located in easements and backyards. Manholes located in front yards and in streets do not require markers.
- E. Sewer line pipeline markers shall be installed along sewer force mains at valves and at fittings that cause a change in direction.

PART 3 - EXECUTION

3.01 INSTALLATION

- A. Sanitary Sewer Pipelines: Refer to Section 3100
- B. Sanitary Sewer Service Lines: Refer to Section 3200

END OF SECTION 3000

SECTION 3100

INSTALLATION OF SEWER PIPE, FITTINGS, AND MATERIALS

PART 1 - GENERAL

1.01 WORK INCLUDED

- A. Installation of sanitary sewer pipelines.
- B. Point repairs on existing sanitary sewer pipelines.

1.02 RELATED WORK

- A. Section 2300 - Excavation, Backfilling, and Compacting.
- B. Section 3000 – Sewer Pipe, Fittings, and Materials.
- C. Section 3200 - Sanitary Sewer Service Lines.
- D. Section 3300 - Manholes.
- E. Section 3600 - Cast-in-place Concrete.
- F. Section 5200 - Inspection and Testing of Sewer Lines, Manholes, and Service Lines.
- G. Section 6000 - Pavement Repair.

1.03 DEFINITIONS

- A. New Sewer Lines – Sewer lines installed in such a manner that there is no sewage flow during construction.
- B. Replacement Sewer Lines – Sewer lines installed in a trench while there is a flow from "live" service connections.
- C. Point Repairs - Replacement of a short section (less than 50 feet in length) in an existing sewer lines.
- D. Force Mains - Sewer pipelines that transport wastewater under pressure from a pump station to a discharge point.

1.04 QUALITY ASSURANCE

- A. Inspect all sewer lines per Section 5200 - Inspection and Testing of Sewer Lines, Manholes, and Service Lines.

1.05 SUBMITTALS

- A. Submit to the Engineer for approval all materials and procedures not described in these specifications.

1.06 REFERENCES

- A. Not Used.

1.07 PROTECTION

- A. In all cases, the Contractor is responsible for protecting public and private property; protecting any person or persons who might be injured as a result of the Contractors' Work.
- B. All utilities shown on the plans may not represent the exact location; however, the Contractor is responsible for verifying these locations and contacting "Arkansas One Call System" before excavating.

PART 2 - PRODUCTS

2.01 BEDDING AND BACKFILL

- A. Refer to Section 2300 - Excavation, Backfilling, and Compacting.

2.02 PIPE, FITTINGS, AND MATERIALS

- A. Refer to Section 3000 – Sewer Pipe, Fittings, and Materials.

2.03 MANHOLES, MANHOLE FRAMES, AND COVERS

- A. Refer to Section 3300 - Manholes.

2.04 CONCRETE

- A. Refer to Section 3600 - Cast-In-Place Concrete.

PART 3 - EXECUTION

3.01 EXCAVATION - GENERAL

- A. Perform excavation and prepare bedding in accordance with Section 2300 - Excavation, Backfilling, and Compacting.
- B. Never lay pipe in a water-filled trench, or when trench conditions or weather are unsuitable for such Work.
- C. Divert surface water and de-water trenches during excavation.
- D. Excavate for bells so that the entire barrel of the pipe will be uniformly supported on the pipe bedding before placing pipe in the trench.

3.02 LAYOUT

- A. The Contractor shall install sewer lines, wyes, and manholes as shown on the Plans.

3.03 SHALLOW BURY

- A. Ductile iron pipe shall be required when the existing grade or the proposed finish grade, whichever is less, provides less than 36 inches of cover. The ductile iron pipe shall extend from manhole to manhole. The ductile iron pipe shall meet the requirements of Section 3000 – Sewer Pipe, Fittings, and Materials, of these Specifications.

3.04 PIERS

- A. Install concrete piers as indicated on the plans per Section 3600 - Cast-In-Place Concrete.

3.05 STEEP GRADES

- A. Whenever the grade of the sewer line exceeds 15 percent, ductile iron pipe shall be required. The ductile iron pipe shall meet the requirements of Section 3000 – Sewer Pipe, Fittings, and Materials, of these Specifications.
- B. Sewers on 15 percent slopes or greater shall be anchored securely with concrete anchors spaced as follows:
 - 1. Not over 36 feet center to center on grades 15 percent and up to 35 percent.
 - 2. Not over 24 feet center to center on grades 35 percent and up to 50 percent.
 - 3. Not over 16 feet center to center on grades 50 percent and over.
- C. Anchor collars should be placed on downstream side of bell. Where no bell is available, a retainer gland shall be installed.

3.06 CONCRETE DAM

- A. Concrete dams shall be constructed at each connection location of new sewer pipe to the existing sewer system. Dams are to be constructed to control the migration of groundwater from the new sewer trench to the exiting sewer system. Dams shall be constructed in the sewer trench, outside the limits of excavation for manholes.
- B. Hand excavate around the sewer pipe into undisturbed earth a minimum of six inches into bottom of the trench and the trench wall perpendicular to the pipe. The hand excavated void around the pipe shall be filled with concrete and a form shall be used to hold the concrete in place. The form may be left in place after backfilling and restoration. The dam shall be a minimum 8-inches thick and extend two (2) feet above the top of the bedding for the pipe.

3.07 PIPE INSTALLATION

- A. Inspect each joint of pipe carefully internally and externally before it is placed in the trench. Plainly mark and separate from the remaining pipe any joint found to be cracked, warped, or otherwise damaged. Remove these damaged joints from the project site as soon as possible.
- B. Cut pipe in a neat and workmanlike manner without damage to pipe or pipe lining when trimming joint length. Cut ends shall be beveled according to the manufacturer's recommendations to prevent damage to the bell gasket. Cut ends for Protecto 401 lined pipe shall be immediately repaired using a field repair kit.
- C. Lay all pipe with the bell upstream.
- D. Use proper equipment for lowering sections of pipe into trenches. Lower pipe carefully into the trench so the spigot and bell will not become contaminated.
- E. Lay each pipe joint to line and grade using laser beam grade light, keeping a minimum of six inches between the pipe and the trench wall.
- F. Keep the pipe joints' interior clean from all dirt and other foreign matter as the Work progresses. Maintain the pipe's interior cleanliness until accepted or put in service.
- G. Close the open ends of the pipeline temporarily with an appropriate manufactured watertight plug at the end of each day's Work or when discontinuing pipe installation for an appreciable period.

H. COLD WEATHER INSTALLATION

1. The City reserves the right to order pipe installation discontinued whenever, in its opinion, there is danger of the quality of work being impaired because of cold weather. The Contractor shall be responsible for heating the pipe and jointing material so as to prevent freezing of joints. Do not lay any pipe on frozen ground. No flexible or semi-rigid pipe shall be laid when the air temperature is less than 32o F unless proper precautions per the manufacturer's recommendations are taken by the Contractor and the method is approved by the Engineer and City.
2. When pipes with rubber gaskets or resilient-type joints are to be laid in cold weather, sufficiently warm the gasket or joint material so as to facilitate making a proper joint.

I. TRACER WIRE

1. Tracer wire shall be installed on all buried sewer force mains.
2. Tracer wire shall be installed 6-inches above the top of the pipe.

J. MARKING TAPE

1. Marking tape shall be installed on all buried sewer pipelines. This includes gravity sewer mains, sewer force mains, and gravity sewer laterals.

3.08 PIPE TO PIPE CONNECTIONS

A. Make all pipe joints in strict accordance with the manufacturer's recommendation and as stated below for the particular type of connection. Make all joints watertight in accordance with the latest ASTM Standards.

B. Slip-type or Push-on Joints Connection Procedure

1. Clean the bell and spigot end of the pipes prior to jointing thoroughly with a brush. Exercise particular care to clean the gasket seat.
2. Apply pipe lubricant and attach gasket in strict accordance with the specific joint manufacturer's recommendations. Clean and insert the rubber gasket in the gasket seat within the bell. Insert the spigot end of the upstream pipe in the bell of the downstream pipe. Push the upstream joint until it is in firm contact with the shoulder of the bell.

C. Mechanical Joints Connection Procedure

1. Clean thoroughly the spigot end of the pipe, the bell of the connecting pipe, and the rubber gasket as specified for slip-type or push-on joints. Clean the gland in a similar manner.
2. After the gland and gasket are placed on the spigot end of the pipe, a sufficient distance from the end to avoid fouling the bell, insert the spigot end in the fitting bell to the point of firm contact with the bell shoulder. Then advance the rubber gasket into the bell and seat in the gasket seat. Exercise care to center the spigot end within the bell. Bring the gland into contact with the gasket, enter all bolts, and make all nuts hand tight. Exercise continued care to keep the spigot centered in the bell.
3. Make the joints tight by turning the nuts with a torque wrench: First partially tightening a nut, then partially tightening the nut 180 degrees away from it. Work around the pipe

with uniformly applied tension until the required torque is applied to all nuts. Required torque ranges and indicated wrench lengths for bolts are as follows:

Diameter (inches)	Range of Torque Foot Pounds	Length of Wrench (inches)
5/8	40-60	8
3/4	60-90	10
1	70-100	12
1-1/4	90-120	14

D. Reinforced Flexible Rubber Couplings

1. Install reinforced flexible rubber coupling only where dissimilar pipe materials are connected.
2. Take care that proper alignment is maintained and a maximum spacing between pipes does not exceed one-half inch.
3. Encase reinforced flexible rubber coupling in Class A concrete as shown on the Standard Details.

3.09 WYE FITTINGS FOR SERVICE CONNECTIONS

- A. Use in-line wye fittings for all service connections except on ductile iron pipe and polyethylene pipe.
- B. The wye material and joint type must match that of the mainline pipe.
- C. Use taps instead of wyes only on ductile iron pipe and polyethylene pipe.
- D. Install wye branches at the location of live services or as indicated on the construction plans. Install wye connections for services in accordance with the manufacturer's recommendations.
- E. Place Class "A" concrete under each wye branch to prevent cracking or twisting under earth loads.
- F. Mark wyes for future connections using marking tape, tracer wire, yellow nylon rope, and 1/2" x 4' rebar or fence tee-post.
- G. Terminate wyes for future connections in a bell suitable for connection of a four-inch SCH-40 PVC service line. Securely plug all wyes and service stubs for future connections.
- H. For Service Wye Details, see the Standard Detail Drawings.

3.10 CLEANOUTS FOR SERVICE CONNECTIONS

- A. Install cleanouts on service lines at the property line where the main line is in the paved right-of-way, as required by plumbing code, or as indicated on the construction plans.

- B. For Cleanout Details, see the Standard Detail Drawings.

3.11 BACKFILLING AND INSPECTION

- A. Before backfilling, place concrete encasement at transitions between different types of pipe and around all flexible rubber couplings as shown on the Drawings. Use Class A concrete per Section 3600-Cast-In-Place Concrete.
- B. Before backfilling, install concrete anchor collars in accordance with the details at the location and interval and shown on the Drawings. Use Class B concrete and reinforce with steel bars per Section 3600-Cast-In-Place Concrete.
- C. After the pipeline is installed and visually inspected by the Engineer, backfill the trench per Section 2300-Excavation, Backfilling, and Compacting.
- D. Test the pipeline per Section 5200-Inspection and Testing of Sewer Lines, Manholes, and Service Lines.
- E. Repair all pavements per Section 6000-Pavement Repair.
- F. Repair all incidental damage to buildings, structures, utilities, pavements, landscaping, etc.
- G. Repair sodded and grass areas to original condition.

3.12 CONNECTION OF NEW SEWER LINES TO EXISTING SEWER LINES

- A. Construct, clean, test, and obtain Engineer's approval for sewer lines and manholes before connecting new sewer lines to the existing sewer.
- B. If, in the opinion of the Engineer, conditions exist which require connection prior to final line acceptance, plug all lines entering the manhole connecting to the existing system until the new system is accepted. In addition, plug the line leaving the first manhole upstream. Never allow water being used to flush the new lines to enter the existing system.
- C. All new sewer lines must connect to the existing system at a new or existing manhole. If a new manhole is built over an existing sewer line, do not break out the top of the existing pipe until the new line is accepted.
- D. If a new sewer line is to discharge into an existing manhole, divert the sewage flow around the existing manhole while the tie-in is under construction. Intercept the sewage flow at the existing manhole first upstream from the tie-in construction. Provide suitable pumping equipment and re-routing conduit to pump the sewage around the tie-in construction. Discharge into an appropriate manhole downstream from the construction.
- E. Connection to an existing manhole shall be made by core drilling. A concrete manhole adapter shall be installed on the sewer pipe, and the annular space grouted in accordance to Section 3300 – Manholes.
- F. Connect new sewer lines to existing manholes in a neat, workmanlike manner, to ensure a watertight connection.

3.13 GRAVITY SEWER LINE INSTALLATION – LIVE SEWER LINES AND POINT REPAIRS

- A. Install sewer lines and point repairs as detailed above for new sewer lines with the following exceptions:

1. Divert all upstream flow around the section to be replaced with plugs or pumps. The bedding must be kept dry during installation. If trench bottom is too wet, excavate wet portion and replace with bedding material.
2. Make transitions to original pipe using materials and procedures specified. Take care that replacement pipe is aligned properly with no offsets. Install concrete encasement around transitions. Take care that no concrete from the encasement enters the existing pipeline. If this occurs, remove the concrete.
3. At the end of each day's work, and when for any reason the laying of pipe will be discontinued for an appreciable period, place a temporary section of pipe in the live line.
4. Pressure testing is not required. Visual and television testing are required.
5. Mandrel testing is required.
6. Service line pressure testing is not required.
7. A temporary debris catcher, as shown in the Standard Detail Drawings, shall be used in the downstream manhole.

3.14 GRAVITY SEWER LINE INSTALLATION - AERIAL CROSSINGS

- A. Construct piers as shown on Drawings.
- B. Install encasement pipe on piers to grade.

3.15 FORCE MAIN PIPE INSTALLATION

- A. Install all pipe and fittings to the line and grade as detailed on the Drawings. All bolted valves, fittings, etc. shall be installed the same as water lines. Refer to Section 4100.
- B. The force main shall have tape marked sewer installed in the trench 18" above the top of the sewer force main.
- C. Remove all dirt and other foreign matter from the inside of pipe and fittings before they are lowered into the trench. Keep pipe and fittings clean during and after laying. Take care to keep dirt out of the bells. Plug all pipe openings at the end of each days work or when pipe laying is discontinued.
- D. Use proper equipment for lowering sections of pipe into trenches. Lower pipe carefully into the trench so the spigot and bell will not become contaminated.
- E. Cut pipe in a neat and workmanlike manner without damage to pipe or pipe lining when trimming joint length.
- F. Install pipe with bell ends facing in the direction of laying. Face bells upgrade on lines on an appreciable slope.
- G. When necessary to deflect pipe from a straight line in either the horizontal or vertical plan to avoid obstructions, do not deflect the pipe beyond the point recommended by the pipe manufacturer.
- H. Before backfilling, install concrete thrust blocking in accordance with Standard Details on Plans. Thrust blocking shall be designed based on pressures of at least 25 percent greater than the maximum pump design shutoff head plus a water hammer allowance with an appropriate factor of safety.

- I. Sewer line pipeline markers shall be installed beside all manholes and valve boxes that are located in easements and backyards. Manholes and valve boxes located in front yards and in streets do not require markers.
- J. Test the pipeline per Section 5200-Inspection and Testing of Sewer Lines, Manholes, and Service Lines.
- K. After the pipeline is installed and visually inspected by the Engineer, backfill the trench per Section 2300-Excavation, Backfilling, and Compacting. Repair all pavements per Section 6000-Pavement Repair. Repair all incidental damage to buildings, structures, utilities, pavements, landscaping, etc.
- L. Repair sodded and grass areas to original condition.

3.16 INSTALLATION OF POLYETHYLENE PROTECTION MATERIAL

- A. Polyethylene material, either in tubing form or in the form of flat sheet or rolls, as specified herein, shall be placed around all buried mechanical joints of pipe and fittings, valves, sleeves, couplings, and any other appurtenance with exposed bolts. Any and all iron or steel components installed below ground shall be double wrapped with the polyethylene material.
- B. Ductile iron and steel pipe and appurtenances shall be completely encased in polyethylene tubing material. It is not the intent that the material form an enclosure that is absolutely air or water tight, but to prevent pipe to soil contact.
- C. Polyethylene tubing shall be applied to pipe by one of the following methods:
 - 1. Method "A": Cut polyethylene tubes to a length approximately two feet (2') longer than the length of the pipe section. Slip the tubes around the pipe, centering it to provide a one foot (1') overlap on each adjacent pipe section, and bunching it accordion fashion lengthwise until it clears the pipe ends. Lower the pipe into the trench and make up the pipe joint with the preceding section of pipe. A shallow bell hole must be made at joints to facilitate installation of the polyethylene tube. After assembling the pipe joint, take bunched polyethylene from the preceding length of pipe, slip it over the end of the new length of pipe, and secure in place. Then slip the end of the polyethylene from the new pipe section of the end of the first wrap until it overlaps the joint at the end of the preceding length of pipe. Secure the overlap in place. Take up the slack width to make snug, but not tight, fit along the barrel of the pipe, securing the fold at quarter points with tape.
 - 2. Method "B": Cut polyethylene tubes to a length approximately one foot (1') shorter than the length of the pipe section. Slip the tubes around the pipe, centering it to provide six inches (6") of bare pipe at each end. Make polyethylene snug, but not tight; secure ends. Before making up a joint, slip section of three foot (3') length of polyethylene tube over the end of the preceding pipe section, bunching it accordion fashion lengthwise. After completing the joint, pull the section of three foot (3') length of polyethylene over the joint, overlapping the polyethylene previously installed on each adjacent section of pipe by at least one foot (1'); make snug and secure each end.
- D. Pipe-Shaped Appurtenances. Bends, reducers, offsets, and other pipe-shaped appurtenances shall be covered with double layers of polyethylene in the same manner as the pipe.
- E. Odd-Shaped Appurtenances. Valves, tees, crosses and other odd-shaped pieces which cannot practically be wrapped in a tube, shall be wrapped with two layers of flat sheets or split length of polyethylene tubes. The sheets shall be passed under the appurtenance and brought up around the

body. Seams shall be made by bringing the edges together, folding over twice, and taping down. Slack width and overlaps at joints shall be handled as described in Paragraph 3.13.C.1 above. Tape polyethylene securely in place at valve stem and other penetrations.

- F. Openings in Tubing Material. Openings for branches, service taps, blow-offs, air valves, and similar appurtenances shall be made by making an “X” shaped cut in the polyethylene and temporarily folding the film back. After the appurtenance is installed, tape the slack securely to the appurtenance and repair the cut, as well as any other damaged areas in the polyethylene with tape.
- G. Junctions Between Wrapped and Unwrapped Pipe. Where polyethylene wrapped pipe joins a pipe that is not wrapped, extend the polyethylene tube to cover the unwrapped pipe a distance of at least two feet (2’) and secure the end.
- H. The polyethylene material shall be secured around the pipe and appurtenances by at least three (3) circumferential wraps of tape (see Section 3000 for materials).
- I. All tongs, cables, or chains that are used for lifting pipe and appurtenances that have been encased in polyethylene material shall be adequately padded to prevent damage to the material.
- J. Repair any rips, punctures, or other damage to the polyethylene with tape or with a short length of polyethylene tube cut open, wrapped around the pipe and secured in place.
- K. Polyethylene material shall be stored on the job site in such a manner that it is not exposed to direct sunlight. Exposure during installation shall not exceed forty-eight (48) hours.
- L. Backfill material shall be the same as specified for pipe without polyethylene wrapping. Special care shall be taken to prevent damage to the polyethylene wrapping when placing backfill. Backfill material shall be free from cinders, refuse, boulders, rocks, stones, and/or other material that could damage polyethylene.

3.17 WATER LINE CROSSINGS

- A. Sewer lines installed under a water line must have a clear distance between pipes of at least eighteen (18) inches.
- B. The sewer line shall be installed such that a joint of pipe is centered along the water line and the joints are as far as possible from the water line.
- C. If 18-inches of clearance cannot be provided or when the water main must pass under the sewer main, either the sanitary sewer main or the water main shall be encased in twenty (20) feet of watertight encasement pipe, centered over the point of crossing. Crossings that are not perpendicular will require more than twenty (20) feet of encasement. The encasement shall extend a minimum of ten (10) feet perpendicular from the outside edges of the line that is not being encased. The ends of the encasement pipe shall be sealed watertight. Refer to Section 3400 – Steel Encasement Pipe.

3.18 STORM SEWER CROSSINGS

- A. All sewer lines crossing under all concrete storm drains, or any storm drain 30-inch diameter and larger, or all storm drains with multiple pipe runs, shall be installed in steel encasement a minimum of 5 feet either side of the storm drain.

END OF SECTION 3100

SECTION 3300**MANHOLES****PART 1 - GENERAL****1.01 WORK INCLUDED**

- A. This section covers the materials and procedures used in the construction and repair of sanitary sewer manholes.

1.02 RELATED WORK

- A. Section 2300 – Excavation, Backfilling, and Compacting.
- B. Section 3100 – Installation of Sewer Pipe, Fittings, and Materials.
- C. Section 3200 – Installation of Sewer Service Lines.
- D. Section 3600 – Cast-in-Place Concrete.

1.03 SUBMITTALS

- A. Furnish Shop Drawings and Submittal Data for approval prior to the delivery of any pre-cast manhole sections.
- B. Submit for approval any materials not listed specifically below.

1.05 REFERENCES

- A. Not Used.

1.06 MANHOLE DIMENSIONS AND LAYOUT

- A. Construct all manholes in accordance with the Standard Manhole Details in Standard Detail Drawings.
- B. The required dimensions on manholes are:
 - 1. Cone section height: 24 inches, minimum; 36 inches, maximum.
 - 2. Throat section height: 18 inches, maximum.
- C. Locate the manhole so the centerlines of all pipelines entering and leaving pass through the center of the manhole.
- D. The following are minimum manhole diameters for sanitary sewers entering/exiting a manhole at the following range of angles:

Pipe Size	<u>MANHOLE DIAMETERS</u>	
	Pipes Entering/Leaving At 0° - 45° Bend	Pipes Entering/Leaving at 45° - 90° Bend
8" - 15"	48"	48"
16" - 30"	60"	60"
33" - 42"	72"	72"

1.07 PROTECTION

- A. In all cases, the Contractor is responsible for protecting public and private property; and, protecting any person or persons who might be injured as a result of the Contractor's work.
- B. All utilities shown on the plans may not represent the exact location; however, the Contractor is responsible for verifying these locations and contacting "Arkansas One Call System" before excavating.

PART 2 - PRODUCTS

2.01 WATER FOR MORTAR AND GROUT

- A. Water: Potable water free from injurious amounts of acids, alkalis, oils, sewage, vegetable matter, and dirt.

2.02 CEMENT

- A. Portland Cement, conforming to AASHTO M 85, Type I.

2.03 MANHOLE GROUT

- A. Cementitious non-shrink grout for use in manholes shall be one specially formulated for stopping active infiltration and filling voids in manholes and similar locations. Grout mix shall provide a quick-setting, volume-stable, cementitious product suitable for patching the interior of manholes when mixed and applied according to the manufacturer's recommendations. Grout mix shall be Strong Seal QSR, or equal.

2.04 CAST-IN-PLACE MANHOLES

- A. Construct with Class B concrete only as outlined in Section 3600 - Cast-In-Place Concrete.
- B. Reinforcement shall be as outlined in Section 3600 - Cast-In-Place Concrete.
- C. The frame for the cover shall be installed when the manhole is constructed.

2.05 PRECAST CONCRETE MANHOLES

- A. Conform to the latest requirements of ASTM C478.
- B. Never transport sections to the site until they have achieved a minimum strength of 3,200 psi (80% of 4,000 psi design) as determined by a concrete cylinder test for the concrete batch.

- C. Mark each piece plainly with manhole numbers and date of manufacture so it can be installed in the proper location, as shown on the plans.
- D. Make sure factory-installed cutouts in the bottom section are appropriate for the pipe being laid.
- E. Pipe connections at manhole - Cutouts should be equipped with rubber boots to ensure a watertight connection. Material shall be equal to A-Lok compression connector or A-Lok G3 Boot System, as manufactured by A-Lok Products, Inc.
- F. Joint Sealant - Flexible rubber sealant for joints in pre-cast manhole sections shall provide permanently flexible watertight joints, shall remain workable over a wide temperature range and shall not shrink, harden or oxidize upon aging. Material shall be equal to RFS Prelubricated Gaskets by Press-Seal Gasket Corporation and shall meet ASTM C 443 and ASTM C 1619 (Classes C and E) requirements.
- G. **No supplemental joint sealant material is permitted.**
- H. All manhole joints shall be sealed with a 6-inch wide butyl external joint wrap material. Material shall be equal to Bidco Butyl Wrap as manufactured by NPC or Infi-Shield® Gator Wrap by Sealing Systems, Inc. The external joint wrap material must be approved by the City of Bryant.
- I. The frame for the cover shall be installed after the cone section is installed in the field.
 - 1. Joint surfaces between the frame, adjustments, and cone section shall be free of dirt, stones, debris, and voids to ensure a watertight seal. Place a flexible butyl gasket joint material, E-Z STIK as manufactured by Press-Seal Gasket Corporation, or equal to ASTM C 990, Section 6.2 Butyl Rubber Sealants, minimum 1/2 inch thick, in two concentric rings along the inside and outside edge of each joint. Position the butt joint for each length of joint material on opposite sides of the manhole. No steel shims, wood, stones, or any material not specifically accepted by the Engineer may be used to obtain final surface elevation of the manhole frame.
 - 2. All grade adjustments, the exterior surfaces of the frame base, and four inches below the top of the manhole cone shall be cleaned with a wire brush and then waterproofed with trowelable bitumastic gasket material, Trowelable EZ-STIK #3 as manufactured by Press-Seal Gasket Corporation, or equal, in accordance with the manufacturer's specifications. A protective polyethylene cover shall be placed over the waterproofing material when backfilling, following sealing of the frame to the manhole. Trowelable bitumastic gasket material is not required if no grade adjustment rings are used.
 - 3. When grade adjustment rings are placed on the manhole structure to obtain proper grade, no more than 18 vertical inches from the top of the frame to the top of the manhole cone may be used.
- K. **REJECTION OF PRECAST MANHOLE SECTIONS**

Precast reinforced concrete manholes, risers and tops shall be subject to rejection for failure to conform to any of the following specification requirements:

 - 1. Fractures or cracks passing through the shell, except for a single end crack that does not exceed the depth of the joint;
 - 2. Defects that indicate imperfect proportioning, mixing and molding;
 - 3. Surface defects indicating honeycombed or open texture;

4. Damaged ends, where such damage would prevent making a satisfactory joint;
5. Infiltration into manhole exceeding allowed limits;
6. The internal diameter of the manhole section shall not vary more than one (1) percent from the nominal diameter;
7. Not clearly marked date of manufacturer, trade name, size designation part number, and ASTM number;
8. Having a deviation more than 1/4" from the straight edge at any point across the top of manhole cone section or riser ring; and/or
9. Having any visible steel bars along inside or outside surface of the manhole except for reinforcement stirrups or spacers used to position the cage during manufacture.

2.06 CORROSION PROTECTION

- A. Manholes located on 15-inch and larger sewer lines shall be epoxy coated on the interior after the manhole is installed.
- B. Manholes on sewer lines within 100 feet of a 15-inch and larger sewer line shall be epoxy coated on the interior after the manhole is installed.
- C. Manholes located within a pump station site shall be epoxy coated on the interior after the manhole is installed.
- D. Manholes in which a force main discharges into shall be epoxy coated on the interior after the manhole is installed. If a new force main connects to an existing manhole that is not epoxy coated then the existing manhole shall be epoxy coated on the interior after the force main is installed.
- E. The products shall only be applied by personnel thoroughly familiar with handling of the coating material, and in accordance with the manufacturer's specifications, recommendations and requirements.

1. Quadex Structure Guard as manufactured by Quadex, Inc., with a minimum thickness of 80 to 100 mils.
2. Strong Seal Epoxy as manufactured by the Strong Company with a minimum thickness of 80 to 100 mils.
3. Raven Ultra High-Build Epoxy Coating, designated as Raven 405, with a minimum thickness of 80 to 100 mils.
4. All epoxies shall meet the following minimum requirements:

Flexural Strength	ASTM D790	6,000 psi
Compressive Strength	ASTM D695	8,000 psi
Tensile Strength	ASTM D638	4,000 psi
Tensile Elongation	ASTM D638	0%
Adhesion	ASTM D4541	Concrete Substrate Failure

F. All manholes not included in items A, B, C and D above shall be coated with Carboline Bitumastic 300 M, or approved equal. Manholes may be coated before or after installation.

- F. Any damage to an epoxy system on existing manholes shall be repaired at the expense of the contractor.

2.07 MANHOLE DROP

- A. Drop on the outside of the manhole: Concrete encased PVC pipe and fittings as specified in Section 3000 – Sewer Pipe, Fittings, and Materials.

2.08 STANDARD MANHOLE FRAME AND COVER

- A. Covers located on manholes owned by the City of Bryant, generally within the Bryant City Limits, shall have the words SANITARY SEWER cast in the top. Also, include two closed pick holes in top side of cover.
- B. Covers located on manholes operated and maintained by the City of Bryant, generally outside the Bryant City Limits, shall have the words SANITARY SEWER cast in the top. Also, include two closed pick holes in top side of cover.
- C. Minimum combined weights of the manhole frame and cover is 210 pounds. Minimum cover weight is 110 pounds. Minimum frame weight is 100 pounds.
- D. All casting shall be AASHTO H-20 rated.
- E. All castings shall be cast with the approved foundry's name, manufacturing foundry mark, part number, and production date in mm/dd/yy format. All castings shall be manufactured in the USA and shall be clearly marked "Made in USA."
- F. All castings: Free from porosity, blowholes, hard spots, shrinkage, distortion and other defects; smooth and well cleaned by sandblasting; manufactured true to pattern.
- G. Frame and cover dimensions: Refer to Standard Detail Drawings. Final casting dimensions may vary one-half the maximum shrinkage possessed by the metal or no more than +/- 1/16 inch per foot.
- H. Cover and frame bearing surface: smooth finish, non-rocking design or machined bearing surfaces to prevent rocking and rattling under traffic.
- I. Cast Iron: ASTM A 48, Class 35B.
- J. Ductile Iron: ASTM A 536, Grade 80-55-06.
- K. Standard manhole ring and covers shall be V1348-1 manufactured by East Jordan Iron Works, Model 1266 manufactured by Deeter Foundary, or approved equal.

2.09 HINGED AND GASKETED MANHOLE FRAME AND COVER

- A. Manhole frame shall be cast or ductile iron. Manhole cover shall be ductile iron. Seal shall be by replaceable t-gasket.
- B. Covers located on manholes owned by the City of Bryant, generally within the Bryant City Limits, shall have the words SANITARY SEWER cast in the top. Also, include two closed pick holes in top side of cover.
- C. Covers located on manholes operated and maintained by the City of Bryant, generally outside the Bryant City Limits, shall have the words SANITARY SEWER cast in the top. Also, include two closed pick holes in top side of cover.

- D. Hinged and gasketed manhole frame and cover shall open to 120°, remove at 120°, and have a safety stop at 90°.
- E. All casting shall be AASHTO H-20 rated.
- F. All castings shall be cast with the approved foundry's name, manufacturing foundry mark, part number, and production date in mm/dd/yy format. All castings shall be manufactured in the USA and shall be clearly marked "Made in USA."
- G. All castings: Free from porosity, blowholes, hard spots, shrinkage, distortion and other defects; smooth and well cleaned by sandblasting; manufactured true to pattern.
- H. Frame and cover dimensions: Refer to Standard Detail Drawings. Final casting dimensions may vary one-half the maximum shrinkage possessed by the metal or no more than +/- 1/16 inch per foot.
- I. Cover and frame bearing surface: smooth finish, non-rocking design or machined bearing surfaces to prevent rocking and rattling under traffic.
- J. Cast Iron: ASTM A 48, Class 35B.
- K. Ductile Iron: ASTM A 536, Grade 80-55-06.
- L. Frame shall be anchored to the manhole cone per standard detail.

2.10 MANHOLE STEPS

- A. Manhole steps shall NOT be installed in any manholes.

2.11 RUBBER WATERSTOP GASKETS

- A. Waterstop gaskets shall be required at ALL manhole connections. Manhole seals shall be concrete manhole adapter by Fernco, A-Lok, or approved equal.

2.12 MANHOLE RISER RING

- A. Manhole riser rings shall be compatible with the size and type of manhole cover with which it will be used.
- B. A maximum of 6 inches of riser rings shall be permitted. Adjustments greater than 6 inches will require grade adjustment rings.

2.13 MANHOLE GRADE ADJUSTMENT RINGS

- A. Grade adjustment rings shall be required to adjust the frame and cover to grade as required.
- B. Sloped grade adjustment rings may be required to match the slope of paved areas.
- C. Grade adjustment rings shall be injection molded, recycled HDPE as manufactured by Ladtech, Inc.

2.14 RAIN STOPPERS (MANHOLE INSERT)

Rain stoppers shall be installed in ALL manholes that are not hinged with gaskets.

A. Polyethylene Insert

1. The manhole insert shall be of corrosion-proof high density polyethylene that meets or exceeds the requirements of ASTM D1248, Category 5, Type III with a minimum impact brittleness temperature of -180.F.
2. The minimum thickness of the manhole insert shall be 3/16".
3. The manhole insert shall have a strap for removing the insert. The strap shall be made of minimum 1" wide woven polypropylene or nylon webbing, with the ends treated to prevent unraveling, Stainless steel hardware shall be used to securely attach strap to the insert.
4. The manhole insert shall have one or more vent holes or valves to release gases and allow water inflow at a rate no greater than 5 gallons per 24 hours. The valve shall be installed by the manufacturer at the factory.
5. There shall be a minimum 10-year warranty on the body of the dish and a 5-year warranty on all other parts of the insert.
6. The insert shall have proof of durability in traffic impact loads and shall have an Engineer certified proof test passing H-20 loading.

B. Stainless Steel

1. Stainless steel inserts shall be installed at locations with pipe size diameters of outfalls 15 inches or greater and as directed by the Engineer.
2. Insert shall be 304 stainless steel.
3. The manhole insert shall be as manufactured by Inflow Systems, Inc., Largo, Florida or approved equal.

PART 3 - EXECUTION

3.01 MANHOLES - GENERAL

- A. Perform excavation and prepare base area in accordance with Section 2300 - Excavation, Backfilling, and Compacting.
- B. Never install base in a water filled excavation.
- C. Place base per the Standard Detail Drawings and Section 3600 - Cast-In-Place Concrete. Extend base a minimum of six inches beyond finished sides of manhole.
- D. Extend all pipes entirely through the manhole wall so that a joint occurs no closer than 24 inches outside the manhole wall.
- E. Pipe installed for future extensions shall have one full joint of pipe installed
- F. After manhole is constructed, wait no less than 48 hours, then backfill per Section 2300 - Excavation, Backfilling, and Compacting.

3.02 CAST-IN-PLACE MANHOLES

- A. Dimension and layout: Per City of Bryant Detail Drawings and Tables. The top section or cone must be concentric with the barrel unless otherwise noted.
- B. The frame shall be set in accordance with City of Bryant Details. The frame shall be installed to match the slope of paved areas.
- C. Install rubber waterstop gaskets in the walls around all pipes.
- D. Interior finish: Smooth, free of fins or sharp edges.
- E. Flow channels shall be shaped and formed in each manhole to provide a smooth transition of flow from all inlets to the outlet. The bench wall shall be formed from the center of the manhole to the outlet pipe in the shape of a "U" as shown in the Standard Details.
- F. Care should be taken to prevent the end of the pipe from deflecting, due to loads imposed by the weight of the concrete.
- G. Construction joints on manholes of excessive depth shall be connected with reinforcement approved by the Engineer.

3.03 PRECAST MANHOLES

- A. Dimension and layout: Per City of Bryant Detail Drawings. The top section or cone must be concentric with the barrel unless otherwise noted.
- B. The bottom section for pre-cast manholes shall be manufactured as an integral part of the manhole base slab.
- C. Install remaining sections in a truly vertical plane.
- D. The frame shall be set in accordance with City of Bryant Details. The frame shall be installed to match the slope of paved areas.
- E. Fill space between pipe and periphery of cutout on the interior of the manhole with non-shrink grout from the bottom of the invert to the spring line of the sewer pipe (1/2 pipe depth).
- F. Grout joints between sections, interior only.
- G. Interior finish: smooth, free of fins or sharp edges.
- H. Flow channels shall be shaped and formed in each manhole to provide a smooth transition of flow from all inlets to the outlet. The bench wall shall be formed from the center of the manhole to the outlet pipe in the shape of a "U" as shown in the Standard Details.
- I. Grout and/or plug lifting holes for manholes.
- J. All manhole joints shall be sealed with an external joint wrap material.

3.04 DROP MANHOLES

- A. Install a drop manhole when the vertical difference between the pipe entering and leaving the manhole exceeds two (2) feet.
- B. Construct manhole base, barrel, and top per the requirements for cast-in-place or pre-cast manholes.

- C. Construct drop of PVC pipe and fittings per Standard Details.
- D. Encase the pipe and fittings in Class A or B concrete as per Standard Details.

3.05 MANHOLE FRAME AND COVER

- A. Set the manhole frame for Cast-In-Place manholes in Class B concrete as shown on the Standard Details as an integral part of the manhole construction.
- B. Set manhole frame and cover top level and to the elevation shown on the Drawings. In public rights-of-way, set the ring and cover flush with pavements, sidewalks, or other paved surfaced areas.

3.06 MANHOLE INVERT

- A. Invert depth at the flow line: the same as the pipe diameter.
- B. In curved inverts, make curves with the longest possible radius to facilitate smooth flow and the insertion of cleaning and televising equipment.
- C. Flow channels shall be shaped and formed in each manhole to provide a smooth transition of flow from all inlets to the outlet. The bench wall shall be formed from the center of the manhole to the outlet pipe in the shape of a "U" as shown in the Standard Details.
- D. Invert materials and finish: Class B Concrete, smooth finish.
- E. Invert grade: Constant, smooth grade; no offsets.
- F. Bench: Slope grout upward from the edge of the invert to the manhole wall.
- G. Form a flow channel in the bench for any services stubbed into manhole. Form invert and finish per above.
- H. Cut the upper half of any pipe extending inside the manhole wall flush with the wall. Smooth rough edges with grout.

3.07 MANHOLE REPAIRS

- A. Make all repairs in accordance with these specifications.
- B. Use manhole grout in patching around new taps.
- C. Plaster all brickwork with mortar.

3.08 MANHOLE ADJUSTMENTS

- A. Manhole riser rings may be used to raise manhole covers to grade.
- B. Manhole riser rings shall be sealed with Adeka P-201 or Manus-Bond 75AM to create a water tight seal.
- C. Adjustments greater than 6 inches will require grade adjustment rings in accordance with the details.
- D. The exterior surfaces of the frame base, and four inches below the top of the manhole cone shall be cleaned with a wire brush and then waterproofed with trowelable bitumastic gasket material,

Trowelable EZ-STIK #3 as manufactured by Press-Seal Gasket Corporation, 6-inch wide butyl external joint wrap material, or equal, in accordance with the manufacturer's specifications. A protective polyethylene cover shall be placed over the trowelable waterproofing material when backfilling, following sealing of the frame to the manhole.

- E. The throat section height shall not exceed 18 inches. The throat section shall be defined as the distance from the bottom of the integral cast manhole ring to the top of the manhole cover.

END OF SECTION 3300

SECTION 3400
STEEL ENCASEMENT PIPE

PART 1 - GENERAL

1.01 WORK INCLUDED

- A. Provide encasement pipe jacked through bored tunnel for crossing of water lines under roadways where shown on the Drawings.
- B. Provide encasement pipe by open cut construction where shown on the Drawings.
- C. Pulling or jacking carrier pipe through encasement pipe.
- D. Providing synthetic end seals at ends of encasement pipe.

1.02 RELATED WORK

- A. Section 3100 – Installation of Sewer Pipe, Fittings, and Materials
- B. Section 4100 – Installation of Water Pipe, Fittings, and Materials

1.03 REFERENCES

- A. American Society for Testing and Materials (ASTM):
 - 1. ASTM A139 Specification for Electric-Fusion (Arc) - Welded Steel Pipe (sizes 4” and over).
 - 2. ASTM A211 Specifications for Spiral-welded Steel or Iron Pipe.
- B. American Welding Society (AWS):
 - 1. AWS D1.1 Structural Welding Code.

PART 2 - PRODUCTS

2.01 MATERIALS

- A. Encasement pipe: Smooth wall steel pipe conforming to ASTM A-53 / ASTM A283 / ASTM A-135, Grade B, CW, physical tests only (no hydrostatic test required). The pipe shall have beveled ends prepared for welded joints. The pipe steel shall have a minimum yield strength of 35,000 psi.
- B. Welding materials: Type required for materials being welded and conforming to applicable AWS Specifications.
- C. Grout: Cementitious grout shall consist of a preblend of lightweight aggregate, cement, fly ash and admix to prevent segregation and promote expansion upon setting. Loose bulk density for the dry mix materials shall be 30 to 35 pounds per cubic foot. Grout shall equal or exceed Strong-Seal Grout 250 - Product Code 2133 and shall be packaged in 2 cubic foot bags.
- D. Flowable Fill: Flowable fill shall conform to Section 206 – Flowable Select Material of the Arkansas State Highway and Transportation Department’s Standard Specifications for Highway Construction, latest edition.

- E. Casing Spacers: Shall be stainless steel, Cascade Model CCS as manufactured by Cascade Waterworks Mfg. Co., or approved equal.
- F. Casing End Seals: Casing end seals shall be one-piece and be of the pull-over type construction. Overlapping style end seals are not permitted. Casing end seals shall be of a synthetic material that is designed for the specific application. Casing end seals shall be secured to the encasement pipe and the carrier pipe with stainless steel bands. Casing end seals shall be Cascade Model CCES, or approved equal.
- G. Polyethylene Encasement: Polyethylene encasement shall be in conformance to ANSI/AWWA C105/A21.5, latest revision.

2.02 MINIMUM THICKNESS

- A. The encasement pipe shall be capable of supporting all traffic and earth loads. The Contractor shall submit design calculations supporting the selection of the encasement pipe thickness used.
- B. Minimum wall thickness for encasement shall be as follows:

<u>Diameter of Encasement Pipe</u>	<u>Minimum Wall Thickness</u>
20" or less	0.250" (1/4")
24"	0.3125" (5/16")
30"	0.3750" (3/8")
36"	0.500 (1/2")
48" to 66"	0.625" (5/8")
72"	0.750" (3/4")

Sizes not listed above shall be determined on an as-needed basis by the City.

- C. When boring under railroad right-of-way, minimum thickness shall be determined by railroad standards.

2.03 MINIMUM DIAMETER

- A. The minimum diameter for encasement pipe shall be such that the carrier pipe, along with casing spacers and joint restraints, will not bind against the inside of the encasement pipe during installation. The minimum diameter of encasement pipe shall be as follows:

<u>Diameter of Carrier Pipe</u>	<u>Diameter of Encasement</u>
2"	6"
3"	6"
4"	8"
6"	12"
8"	16"
10"	20"
12"-14"	24"
16"-18"	30"
20"-24"	36"
30"-36"	48"
42"	60"
48"	66"
54"	72"

PART 3 - EXECUTION

3.01 EXCAVATION

- A. Highway Bore: Do not set up equipment or begin excavating pit on state highway without permission of Arkansas Highway and Transportation Department District Engineer or his authorized representative.
- B. Railroad Bore: Do not set up equipment or begin excavating pit on or near railroad property without permission of the respective railroad company.
- C. Highway and railroad permits will be obtained by the City. Contractor shall coordinate with City on obtaining Right-of-way permit from railroad and shall conform to all requirements there in.

3.02 INSTALLATION, ENCASEMENT PIPE

- A. General: Install encasement pipe at grade and alignment shown on Drawings. Allow for height of casement spacers when establishing grade for gravity line encasement pipe. Refer to Standard Details.
- B. Bores:
 - 1. Excavate pits and trenches required at each side of crossing to minimum width and length necessary for boring and jacking operation and carrier pipe installation.
 - 2. Carefully set steel guide rails in pit to attain specified grade and alignment.
 - 3. Keep pit pumped free of standing water. Maintain pit bottom to provide stable base for rails and equipment and firm footing for workmen. Granular material used in bottom of pit will not be paid for as "Additional Trench Bedding".
 - 4. Provide temporary sheeting and bracing as necessary to prevent earth slides.
 - 5. Bore tunnel and simultaneously jack encasement pipe forward one section at a time. Connect sections by full penetration butt welding performed in accordance with AWS D1.1.
 - 6. Remove excavated soil from boring operation as it enters pit and dispose of it offsite.
 - 7. End seal shall be installed after the carrier pipe has been installed.
- C. Open Cut:
 - 1. Excavate trench as required.
 - 2. Steel encasement pipe shall be installed, bedded, and backfilled the same as ductile iron pipe.
 - 3. Steel encasement pipe shall be poly wrapped.
 - 4. End seal shall be installed after the carrier pipe has been installed.

3.03 INSTALLATION, CARRIER PIPE

- A. Joint pipe as specified in Section 3100 or 4100. Pull or jack carrier pipe through encasement pipe. Do not allow cables or jacks to be in direct contact with carrier pipe while pulling or jacking pipe. Use timber or padded steel member.
- B. A minimum of three casing spacers shall be installed on pipe up to 20-foot pipe joints.
- C. All carrier pipe installed through the encasement shall be fully restrained. Over-belling of the carrier pipe shall be prevented.

3.04 BACKFILL

- A. Prior to backfill, seal ends of encasement pipe with an end seal as shown in the Standard Details.
- B. Use material excavated from pit.
- C. Backfill against ends of encasement pipe.
- D. Backfill pit and carrier pipe in same manner as specified in Section 2300 – Excavation, Backfilling, and Compacting.

3.05 CLEANUP

- A. Clean up ground surface around work area in same manner as specified for line work in Section 2300 - Excavation, Backfilling and Compacting.

END OF SECTION 3400

SECTION 3500**SEWAGE PUMP STATIONS**

PART 1 - GENERAL

1.01 GENERAL REQUIREMENTS

- A. This Section pertains to the requirements for the design and construction of submersible type lift stations, which are the primary type constructed as part of private development. Their design and approval will be handled on a case-by-case basis.
- B. A registered Civil Engineer shall seal the civil portion of the drawings. A registered Electrical Engineer shall seal the electrical portion of the drawings. All engineers shall be registered in the State of Arkansas.
- C. Pump stations meeting or exceeding the requirements set herein will be approved. Any proposed alteration of the pump station dimensions, equipment, controls, etc. from the standards set forth herein will be approved only upon the submittal of plans and specifications of the proposed changes to the City, and upon the City's written approval.
- D. Pump Stations, in general, shall be submersible type including a minimum of two (2) pumps and motors of minimum pumping capacity of 100 gpm under site operating conditions, wet basin, separate valve pit, valves, piping, hatches, guide rails, pump removal components, control center, level controls, interconnecting electrical wiring, incoming power and telephone supply, and all other features regularly and normally required as a part of a complete and functional facility. All work shall be in accordance with site requirements, details in the Drawings, these Standards and the manufacturer's recommendations. Pump stations with check valves, isolation valves, etc. inside the wet well shall not be acceptable.
- E. All Pump Stations shall be designed for and operate on 480 V, three (3) phase power. No deviation from this requirement shall be permitted without the express prior written approval of the City; specifically, approval is required for operation from single-phase power.
- F. The station shall be equipped with a pump control system capable of monitoring the status of the lift station and communicating with the City's existing SCADA system housed at the wastewater treatment plant.
- G. All of the mechanical and electrical equipment shall be an integral package supplied by the pump manufacturer with local representation so as to provide undivided responsibility. The package shall be equal in construction and performance to Flygt Pump equipment and other specific requirements set forth herein and in the approved plans.
- H. The Contractor shall submit to the City for review and approval three (3) sets of shop drawings, detailed specifications, pump warranty, and performance characteristics for all of the equipment and fixtures to be furnished and installed. The Shop Drawings and equipment data shall be submitted with a cover letter, Contractor's stamp of approval, and Engineer's stamp of approval indicating that he has reviewed, checked, and approved the data submitted. The City will review the submittal and render a decision in writing as to the acceptability of the equipment. Without prior written City approval, the item of work may not be accepted.
- I. Any exceptions to this Standard or associated approved Plans shall be submitted in writing and clearly stated. The exceptions must be approved by the City prior to proceeding with the work.
- J. All mounting and fastening hardware shall be stainless steel.

- K. All components of the pump station that are exposed to weather shall be constructed of material that is resistant to corrosion and will not require surface protection throughout the expected life of the lift station. In general, these materials are stainless steel, aluminum, fiberglass reinforced polyester (FRP), and ultraviolet stabilized PVC.
- L. All valves and ductile iron fittings in wet well, dry well or valve pit shall be epoxy coated inside and out. All ductile iron piping coming in contact with wastewater or installed in the wet well, dry well or valve pit shall be coated with epoxy inside and out. Acceptable interior epoxy for ductile iron pipe shall be Protecto 401, or approved equal. Acceptable field applied exterior coating of ductile iron pipe shall be Tnemec Series 66 HB Epoxoline at 4 to 6 mils followed by Series 73 Endura-shield at 2 to 4 mils, or approved equal.

1.02 PUMP STATION SITE

- A. The pump station site shall have minimum dimensions of 50' x 50' with a maximum cross slope of 5%. The site shall have a surface consisting of 8-inches of AHTD Class 7 Crushed Stone. Additional site area may be required depending on the diameter and depth of the wet well and other accessories. Final dimensions of the site shall be determined by the Bryant Water and Sewer Department.
- B. The City of Bryant must own the land, by deed and not by plat, on which sewage pump stations are located or anticipated to be constructed.
- C. The pump station shall be provided with a 16 foot wide access drive to the nearest public road. The access drive shall have a surface consisting of 8-inches of AHTD Class 7 Crushed Stone. If the slope is greater than 10%, the surface shall be constructed in such a way that the surface material cannot creep down slope. The drive shall enter the public road at a curb cut.
- D. The pump station site perimeter shall be secured by a minimum 6' high wooden fence or 6' high black nylon coated chain link fence. Chain link fence shall have 3 strands of barb wire at top of fence. Wooden fence shall have 4"x4" pressure treated posts. Chain link posts shall be a minimum of 3" SCH 40 galvanized steel. Wooden and chain link gate posts shall be a minimum of 4" SCH 40 galvanized steel. Wooden fence rails shall be pressure treated 2"x4". A minimum of 3 rails shall be provided for wooden fence. All pickets shall be constructed of pressure treated pine, and shall be a minimum of 1"x6"x6". All hardware used to anchor the pickets to the rails shall be designated for use with pine pickets. A 16' wide double gate with lockable hasp shall be provided. Gates shall have sufficient clearance above finished grade so that the gate will fully open a minimum of 90 degrees.
- E. The wetwell shall be designed so that there is only one pipe entry into the wetwell. Provide a manhole within the pump station site with all wastewater flowing through the manhole and outlet pipe to the wetwell. No other connections between the manhole and wetwell are permitted.

1.03 OPERATING CONDITIONS

- A. The characteristics and operating conditions of the lift station and pumps shall be provided in detail as part of the ENGINEER'S design and submitted for approval to the City.
- B. Prior to installation the Contractor shall submit the following information for each pump to the City for review and approval:
 1. Pump capacity in gallons per minute;
 2. Total dynamic head (TDH) and operating RPM; Use C=130
 3. Motor horsepower;

4. Motor rpm;
 5. Motor voltage, phase and cycle;
 6. Make and model number; and
 7. Pump curves for the pumps to be provided.
- C. Pump station acceptance will be based upon pump drawdown tests. The acceptable range is +10% and -5% of the reported pump capacity in GPM. Pump flows outside of this range will result in non-compliance of the standard and the pump station will not be accepted.

1.04 NOTES TO DESIGN ENGINEER

A. SIZING OF WET BASIN

1. The wetwell storage depth below the lowest inlet (new pump stations shall only have one inlet into the wetwell) shall be a minimum of 5'-0" and shall also meet the following criteria:
 - a. All pumps OFF shall be set at the pump manufacturer's recommended level but no less than 1'-6" from the bottom of the wetwell.
 - b. The distance between all pumps OFF and the lead pump ON shall be set to provide storage capacity equal to:

$$\frac{15 \times \text{RATED PUMP GPM}}{4}$$

4

(i.e. 15 minute cycle minimum)

- c. The lag pump ON shall be set a minimum of 6" above the lead pump ON and a minimum of 12" below the lowest inlet invert.
- d. The high water alarm float shall be set a minimum of 6" above the lag pump ON and minimum of 6" below the lowest inlet invert.
- e. All level control elevations shall be set below the lowest inlet invert.

1.05 SMALL DIAMETER PRESSURE SEWERS

- A. Small diameter pressure sewer systems incorporating the use of individual home grinder pump units will be allowed on a case-by-case basis subject to the written approval of the City of Bryant and the Arkansas Department of Health. In general, these systems shall only be considered in areas where the surrounding areas are currently served by sanitary sewers and the site cannot be sewer by gravity.
- B. The maintenance of the grinder pump station and building force main to the point of connection with the collector force main shall be the responsibility of the home owner if the low pressure grinder pump station is not manufactured by Environment One Corporation. The City shall only be responsible for the maintenance of the grinder pump station and building force main to the point of connection with the collector force main if the station is manufactured by Environment One Corporation.

- C. Refer to Section 3501 “Individual Sewage Grinder Pump Stations” for requirements on Individual Sewer Grinder Pump Stations.

1.06 COVER ABOVE CONTROL PANEL

- A. Control panels shall be equipped with a slanted cover over the control panel. Provide a minimum clearance of 4 feet above the control panel. Covers shall be a minimum of 8 feet by 10 feet with metal posts and roof. Provide a light with weatherproof switch suitable for outdoor use under the cover.

1.07 CONCRETE SLAB FOR CONTROL PANEL

- A. Control panels shall be mounted on a concrete slab. Concrete slab shall be a minimum of 8 feet x 10 feet x 4 inches thick with reinforcement.

1.08 PUMP STATION WARRANTY

- A. Pump station warranty shall be two (2) years from the date of acceptance per City maintenance bond requirements.

PART 2 – PRODUCTS

2.01 PUMPING EQUIPMENT

- A. Pumps shall be of the submersible type for handling raw unscreened sewage. Pump volute, motor and seal housing are to be high quality gray cast iron. Impeller shall be either cast iron or cast bronze of a non-clog design capable of handling minimum three (3) inch sphere solids, fibrous material, heavy sludge, and other matter found in normal sewage applications. Impeller shall have pump-out vanes on the back shroud of the impeller to keep pumped material away from the seal area and increase operating life. Impeller shall be either slip fit or taper fit with key to securely lock the impeller to the driving shaft. The pump volute shall be fit with a replaceable bronze wear ring to minimize wear on the impeller and help achieve longer balanced operating life. All fasteners shall be of stainless steel.
- B. All mating surfaces where watertight sealing is required shall be machined and fitted with nitrile rubber O-rings. Sealing shall be accomplished when metal-to-metal contact is made, resulting in controlled compression of the rubber O-rings without requirement of a specific torque limit.
- C. The pump shall be provided with a mechanical rotating shaft seal system running in an oil reservoir having separate, constantly lubricated lapped seal faces. The lower seal unit between the pump and oil chamber shall consist of one (1) stationary seat and one (1) rotating ring held in place by its own spring. The lower seal shall be removable without disassembling the seal chamber. The upper seal between the motor and the seal chamber shall be of the same design with its own separate spring system. The seals shall require neither maintenance nor adjustment, but shall be easily inspected and replaceable. The shaft sealing system shall be capable of operating submerged to pressures equivalent to two hundred (200) feet. No seal damage shall result from operating the pump unit out of its liquid environment. The seal system shall not rely upon the pumped media for lubrication.
- D. The seal chamber shall also be equipped with a seal failure sensor probe which will sense water intrusion through the lower seal. This sensor is to be connected to an alarm in the control panel to indicate lower seal failure.
- E. The stator winding, rotor and bearings are to be mounted in a sealed submersible type housing. Insulation utilized in the stator windings shall be Class F with maximum temperature capability of 155.C. Motor housing shall be filled with a high dielectric oil to give superior heat transfer and

allow the bearing to run in a clean, well lubricated environment; or the housing shall be air filled with grease lubricated bearings. The pump and motor are to be specifically designed so that they may be operated partially or completely submerged in the liquid being pumped. The pump should not require cooling water jackets. Stator shall be securely held in place with a removable end ring and threaded fasteners so that it may be easily removed in the field without use of heat or press. Shaft shall be of stainless steel and supported by ball bearings. Motor shall be provided with heat sensing units attached to the motor windings which shall be connected to the control panel to shut down pump if overheating occurs.

- F. Pump motor cable and heat sensor/seal failure sensor cable shall be suitable for submersible pump applications and this shall be indicated by a code or legend permanently embossed on the cable. Cable sizing shall conform to NEC specifications for pump motors and shall be of adequate size to allow motor voltage conversion (460V to 230V) without replacing the cable. Cable of the proper length shall be provided to eliminate need for splices or junction boxes between pump and "control center". The cable shall enter the motor through a cord cap assembly which is double sealed allowing disassembly and disconnect of the wires and the motor and still not damage the sealed characteristics of the motor housing. Each individual conductor shall be color coded in accordance with generally accepted industry standards. The color coding shall designate the application of the conductor.
- G. The pump mounting base shall include adjustable guide rail supports and a discharge connection with a one hundred twenty-five (125) pound standard flange. The base and the discharge piping shall be permanently mounted in place. The base plates shall be anchored in place utilizing epoxy type anchors with stainless steel studs and nuts as manufactured by HILTI Fasteners, Inc. or equal.
- H. A rail system shall be provided for easy removal of the pump and motor assembly for inspection and service. The system shall not require a man to enter the wetwell to remove the pump and motor assembly. Two (2) rails of minimum two (2) inch stainless steel pipe shall be provided for each pump. The guide rails shall be positioned and supported by the pump mounting base. The guide rails shall be aligned vertically and supported at the top by attachment to the access hatch frame. One (1) intermediate guide rail support is required for each fifteen (15) feet of guide rail length for stainless steel pipe.
- I. The pumps shall be equipped with sliding brackets or rail guides. To insure easy removal of the pumps, the rail guides attached to each pump shall not encircle the rails. A stainless steel lifting chain or manufacturer's pump removal system (similar to the Flygt Lift) of adequate length for the basin depth shall be provided for each pump. Each pump shall be equipped with a permanent, stationary lifting handle with a minimum clearance of 12" between the top of pump and bottom of handle.
- J. The rails and the rail guides shall function to allow the complete weight of the pumping unit to be lifted on dead center without binding and stressing the pump housing. The rail system shall function to automatically align the pumping unit to the discharge connection by a simple downward movement of the pump. No twisting or angle approach will be considered acceptable. The actual sealing of the discharge interface may be of the metal-to-metal contact. No sealing gaskets will be permitted.
- K. Pump warranty shall be provided by the pump manufacturer and shall warrant the units being supplied to the Owner against defects in workmanship and materials for a period of five (5) years under normal use, operation and service. The warranty shall be in printed form and apply to all similar units. A copy of the warranty statement shall be submitted with the approval drawings.

2.02 BASIN, VALVE PIT AND ACCESSORIES

- A. The basin and separate valve pit are to be constructed of precast concrete meeting the requirements of ASTM C-478. Cast-in-place monolithic structures may be substituted with the

prior written approval of the City. Minimum valve vault and wetwell diameter shall be 6'-0'. The actual arrangement of the structures are to be as shown in the approved Plans. The wetwell basin top shall be provided with a six (6) inch stainless steel vent having a downward pointing inlet and screen over the inlet opening. Under certain conditions and situations, the City of Bryant may allow fiberglass basins and valve vaults. The use of fiberglass basins and vaults shall be at the discretion of the City of Bryant.

- B. The basin, valve pit, flat tops, and base slabs are to be constructed of precast or cast-in-place reinforced concrete manhole sections conforming to ASTM C-478. All joints between precast sections shall be made with an approved rubber O-Ring in accordance with ASTM C-443 and a 1/2 inch diameter non-asphaltic mastic conforming to AASHTO M-198 and Federal Specification SS-521-A. All manhole joints shall be sealed with an external joint wrap material. Material shall be equal to Bidco Butyl Wrap as manufactured by NPC or Infi-Shield® Gator Wrap by Sealing Systems, Inc. The top and bottom of the chambers shall be precast or may be poured in place concrete if approved by the Bryant Water and Sewer Department.
- C. The wetwell pump basin and the valve pit chamber shall be enclosed at grade level with a reinforced concrete pad rectangular in shape and extending a minimum of 1'-0' from the chambers outside dimension.
- D. All concrete surfaces within the wet well shall be coated with one of the products listed below. These products shall only be applied by personnel thoroughly familiar with handling of the coating material, and in accordance with the manufacturer's specifications, recommendations and requirements.
 - 1. Quadex Structure Guard as manufactured by Quadex, Inc. with a minimum thickness of 80 to 100 mils.
 - 2. Strong Seal Epoxy as manufactured by the Strong Company with a minimum thickness of 80 to 100 mils.
 - 3. Raven Ultra High-Build Epoxy Coating, designated as Raven 405, with a minimum thickness of 80 to 100 mils.
 - 4. All epoxies shall meet the following minimum requirements:

Flexural Strength	ASTM D790	6,000 psi
Compressive Strength	ASTM D695	8,000 psi
Tensile Strength	ASTM D638	4,000 psi
VOC	ASTM D2584	0%
Adhesion	ASTM D4541	Concrete Substrate Failure
- E. The pump supplier shall provide an aluminum two (2) door access hatch frame and door assembly to be installed in the concrete basin top. This door assembly shall provide access for removal of the pumps and shall support the guide rails. The doors shall be provided with lifting handle, safety latch to hold door in the open position and a hasp suitable for padlock. The doors shall have a nonskid finish and be designed for light, medium, or heavy duty, depending on the location of the pumping station.
- F. An aluminum single door access hatch frame and door assembly similar to the one described above shall be provided for use as entry to the valve pit. Minimum opening for the valve box entry shall be thirty-six (36) inch by thirty-six (36) inch.
- G. A swing check valve with external swing arm and a full port (100% area) eccentric plug valve shall be installed in the valve pit in each pump's discharge piping. A minimum clearance of twelve (12) inches shall be allowed from the bottom of the valves to invert of the pit. A drain shall be

provided from the valve vault to the wetwell. Drain shall have a minimum diameter of 4-inches. A duck-billed check valve shall be provided on the end of the 4-inch drain inside the wetwell. Check valve shall be model TF-1 manufactured by Tideflex, or approved equal. In addition, a 1/2" NPT tap and ball valve shall be provided on the discharge side of the pumps past the valves to facilitate pressure readings for the pump discharge.

- H. All yard piping within the pump station site shall be centrifugally cast ductile iron and shall conform to ANSI Specifications A21.51 and AWWA C-151, latest revision and shall be Pressure Class 350, 300, 250, or 200 wall thickness dependent upon site conditions. All direct buried ductile iron pipe and fittings shall be poly-wrapped.
- I. Force main and gravity pipe shall be DIP or PVC in accordance with Section 3000.
- J. All pipe and fittings inside the wetwell shall be as follows.
 - 1. Pipe 4-inch in diameter and larger shall be ductile iron meeting the requirements of Section 3000.
 - 2. Pipe less than 4-inches in diameter shall be stainless steel.
- K. Sewer line markers shall be in accordance with Section 3000.

2.03 EMERGENCY BYPASS PUMP CONNECTION

- A. An emergency bypass pump connection shall be provided on the force main within the pump station site. Emergency bypass pump connection shall be in accordance with the Standard Sewer Details.
- B. All piping for the emergency bypass pump connection shall be ductile iron meeting the requirements of Section 3000 and shall conform to ANSI Specifications A21.51 and AWWA C-151, latest revision and shall be Pressure Class 350, 300, 250, or 200 wall thickness dependent upon site conditions. All direct buried ductile iron pipe and fittings shall be poly-wrapped.

2.04 GENERAL ELECTRICAL

- A. A single main fusible or breaker disconnect switch of adequate size to provide power for the "control center" and its related components shall be provided by the Contractor. The disconnect switch shall be housed in a NEMA 4X stainless steel enclosure with an external operation handle capable of being locked in the ON position.
- B. Provide a manual transfer switch rated for the station operating voltage and of an ampere rating equal to or larger than the main fuse or circuit breaker rating, with a NEMA 4X stainless steel enclosure with an external operation handle for On/Off/On capable of being locked in either ON position.
- C. Provide a generator inlet connector wired to the manual transfer switch for City's connection of a portable generator. Coordinate with City personnel on type and size of inlet connector before ordering. Inlet shall be weather protected with cap or cover.
- D. A minimum four (4) inch PVC schedule 40 wall conduit shall be provided from the wetwell basin to the control center which will allow the pump power cables, sensor cables and level controls to be pulled through without difficulty and allow the use of one (1) piece cables from the pumps and level controls to the control center. The conduit shall be sealed at the control center to avoid entrance of sewer gases into the control panel.
- E. All vertical conduit and transitions from horizontal to vertical runs shall be rigid metallic conduit. Horizontal, below grade, conduit runs may be either Schedule 40 PVC or rigid metallic conduit.

2.05 CONTROL CENTER

- A. The control center shall be built in a NEMA 4X white epoxy powder painted stainless steel enclosure and shall be suitable for the specified horsepower and voltage for the pumping equipment. The outer door of the panel shall be hinged dead front with provisions for locking with a padlock. Inside shall be a separate hinged panel to protect all electrical components. H-O-A switches, run lights, circuit breakers, etc. shall be mounted such that only the faces protrude through the inside swing panel and no wiring is connected to the back side of the inside swing panel. The control center shall be located so as to provide safe access to the panel while wetwell hatch doors are opened, and shall be positioned so as not to be between the access drive and the wetwell.
- B. Three-phase powered panels shall include a circuit breaker and magnetic starter with three (3) leg overload protection and manual reset for each pump. Single phase powered panels shall include Variable Frequency Drives, PWM type, for each pump, sized to operate 3-phase pumps from the single phase source.
- C. Separate circuit breakers shall be supplied for:
 - 1. A control voltage transformer to reduce supply voltage to 120 volts.
 - 2. 24 volt DC power supply with battery backup, 4 hour capacity, for the float circuit and associated relays.
 - 3. Condensate heater.
 - 4. Transformer for external convenience receptacle, see Par. H. below.
- D. A terminal strip shall be provided to make field connections of pump power leads, level control, seal sensor leads, heat sensor leads, and remote monitor panel interconnections.
- E. The control center shall have a high water alarm built into the main enclosure. The high water alarm shall consist of a flashing alarm light with red Lexan plastic cover or red glass globe with metal guard mounted on top of the enclosure such that it is visible from all directions. An alarm horn shall be mounted on the side of the enclosure. A push to test horn and light button as well as a push to silence horn button shall be provided and mounted on the side of the enclosure.
- F. The control center shall include a condensate heater to protect against condensation inside the enclosure. The heater shall be placed so as not to damage any other component or wiring in the control center.
- G. The control center shall include lightning and surge protection.
- H. The pump station site shall include a GFI convenience outlet with 20 amp breaker and suitable transformer, minimum 2 KVA, or power supply to provide 120 volt single phase power to the convenience outlet.
- I. All component of the control center shall be available from local sources. In particular, items such as circuit breakers, overload protection, relays, starters, VFDs, etc. shall be available and in stock by local sources.
- J. Pump control shall consist of a Multitrode brand "Multismart" Pump Station Manager & RTU. If the pump motors are 20 HP or larger, the Multismart shall include the Energy Monitoring & Motor Protection Module. Provide a serial cell modem compatible with the Multitrode "Pumpview" monitoring service.

- K. Level sensor shall be a Multitrode probe rod, or a submersible level transducer, "LevelRat" by Keller America Inc. Contractor shall coordinate with City personnel for direction before ordering these items.
- L. Provide three tilting float switches, to be suspended in the wetwell, with circuitry in the control center for backup level control and alarm.
- M. In order to maintain unit responsibility and warranty on the pumping equipment and control center, the control center must be accepted in writing by the pump manufacturer as suitable for operation with the pumping equipment.

2.07 SPARE PARTS

- A. The Contractor shall supply one set of spare parts for each pump for each station, including at a minimum the following:
 1. Impeller;
 2. Upper seal assembly;
 3. Lower seal assembly;
 4. Upper bearing assembly;
 5. Lower bearing assembly;
 6. Wear rings; and
 7. O-Rings and gaskets (two (2) sets).
 8. One set of main power fuses if applicable.
 9. Five of each type of fuse used in the control center.

2.08 OPERATION AND MAINTENANCE MANUALS

- A. Three (3) operation and maintenance manuals shall be submitted to the City
- B. Manuals shall include, at a minimum:
 1. Operation instructions;
 2. Maintenance instructions;
 3. Recommended spare parts list;
 4. Lubrication schedules;
 5. Structural diagrams;
 6. As-built wiring diagrams; and
 7. Bill of materials.
 8. Copy of design engineer's pump operating point calculations, population assumptions, average daily flow, and peaking factor

PART 3 – EXECUTION

3.01 SYSTEM OPERATION

- A. On wet well level rise, the lead pump shall start at the lead pump ON elevation. With the lead pump operating, the wet well level shall lower to all pumps OFF and turn off the pump. The alternating function in the control center shall index on stopping of the pump so that the lag pump will start on the next operation.
- B. If the wet well level continues to rise when lead pump is operating, the control system shall energize and start the lag pump. Both lead and lag pumps shall operate together until low level setting turns off both pumps. If level continues to rise when both pumps are operating, alarm level switch shall energize and signal the alarm.
- C. If one pump should fail for any reason, the second pump shall operate. If the Multismart fails, the floats shall operate the pumps.
- D. If the pumps fail to turn off for any reason after receiving the signal for all pumps OFF, a low level alarm shall signal.
- E. All level controls shall be adjustable for level setting from the surface.

END OF SECTION 3500

SECTION 3501**INDIVIDUAL SEWAGE GRINDER PUMP STATIONS****PART 1 - GENERAL****1.01 GENERAL REQUIREMENTS**

- A. This Section pertains to the requirements for the design and construction of individual sewage grinder pump stations.
- B. Small diameter pressure sewer systems incorporating the use of individual home grinder pump units will be allowed on a case-by-case basis subject to the written approval of the City of Bryant and the Arkansas Department of Health. In general, these systems shall only be considered in areas where the surrounding areas are currently served by sanitary sewers and the site cannot be sewerer by gravity.
- C. The maintenance of the grinder pump station and building force main to the point of connection with the collector force main shall be the responsibility of the home owner if the low pressure grinder pump station is not manufactured by Environment One Corporation. The City shall only be responsible for the maintenance of the grinder pump station and building force main to the point of connection with the collector force main if the station is manufactured by Environment One Corporation.
- D. The station shall be a complete factory-built and tested grinder pump unit(s), each consisting of a grinder pump core suitably mounted on an integral stand of stainless steel, tank, electrical quick disconnect (NEMA 6P), pump removal harness, discharge assembly/shut-off valve, anti-siphon valve/check valve assembly, electrical alarm assembly and all necessary internal wiring and controls.
- E. Grinder pump stations shall be complete with all appurtenances and form an integral system. The equipment shall be a product of a company experienced in the design and manufacture of grinder pumps for specific use in low pressure sewage systems. The company shall submit detailed installation and user instructions for its product, submit evidence of an established service program including complete parts and service manuals, and be responsible for maintaining a continuing inventory of grinder pump replacement parts.
- F. The Contractor shall submit to the City for review and approval three (3) sets of shop drawings, detailed specifications, pump warranty, and performance characteristics for all of the equipment and fixtures to be furnished and installed. The Shop Drawings and equipment data shall be submitted with a cover letter, Contractor's stamp of approval, and Engineer's stamp of approval indicating that he has reviewed, checked, and approved the data submitted. The City will review the submittal and render a decision in writing as to the acceptability of the equipment. Without prior written City approval, the item of work may not be accepted.

1.02 OPERATING CONDITIONS

- A. The pumps shall be capable of delivering 15 GPM against a rated total dynamic head of 0 feet (0 PSIG), 11 GPM against a rated total dynamic head of 92 feet (40 PSIG), and 7.8 GPM against a rated total dynamic head of 185 feet (80 PSIG). The pump(s) must also be capable of operating at negative total dynamic head without overloading the motor(s). Under no conditions shall in-line piping or valving be allowed to create a false apparent head.

1.03 WARRANTY

- A. The grinder pump manufacturer shall provide a part(s) and labor warranty on the complete station and accessories, including, but not limited to, the panel for a period of 24 months after notice of City of Bryant acceptance, but no greater than 27 months after receipt of shipment. Any manufacturing defects found during the warranty period will be reported to the manufacturer by the City and will be corrected by the manufacturer at no cost to the City.

PART 2 – PRODUCTS

2.01 PUMP

- A. The pump shall be a custom designed, integral, vertical rotor, motor driven, solids handling pump of the progressing cavity type with a single mechanical seal. Double radial O-ring seals are required at all casting joints to minimize corrosion and create a protective barrier. All pump castings shall be cast iron, fully epoxy coated to 8-10 mil Nominal dry thickness, wet applied. The rotor shall be through-hardened, highly polished, precipitation hardened stainless steel. The stator shall be of a specifically compounded ethylene propylene synthetic elastomer. This material shall be suitable for domestic wastewater service. Its physical properties shall include high tear and abrasion resistance, grease resistance, water and detergent resistance, temperature stability, excellent aging properties, and outstanding wear resistance. Buna-N is not acceptable as a stator material because it does not exhibit the properties as outlined above and required for wastewater service.

2.02 GRINDER

- A. The grinder shall be placed immediately below the pumping elements and shall be direct-driven by a single, one-piece motor shaft. The grinder impeller (cutter wheel) assembly shall be securely fastened to the pump motor shaft by means of a threaded connection attaching the grinder impeller to the motor shaft. Attachment by means of pins or keys will not be acceptable. The grinder impeller shall be a one-piece, 4140 cutter wheel of the rotating type with inductively hardened cutter teeth. The cutter teeth shall be inductively hardened to Rockwell 50 – 60c for abrasion resistance. The shredder ring shall be of the stationary type and the material shall be white cast iron. The teeth shall be ground into the material to achieve effective grinding. The shredder ring shall have a staggered tooth pattern with only one edge engaged at a time, maximizing the cutting torque. These materials have been chosen for their capacity to perform in the intended environment as they are materials with wear and corrosive resistant properties.
- B. This assembly shall be dynamically balanced and operate without objectionable noise or vibration over the entire range of recommended operating pressures. The grinder shall be constructed so as to minimize clogging and jamming under all normal operating conditions including starting. Sufficient vortex action shall be created to scour the tank free of deposits or sludge banks which would impair the operation of the pump. These requirements shall be accomplished by the following, in conjunction with the pump:
 - 1. The grinder shall be positioned in such a way that solids are fed in an upward flow direction.
 - 2. The maximum flow rate through the cutting mechanism must not exceed 4 feet per second. This is a critical design element to minimize jamming and as such must be adhered to.

3. The inlet shroud shall have a diameter of no less than 5 inches. Inlet shrouds that are less than 5 inches in diameter will not be accepted due to their inability to maintain the specified 4 feet per second maximum inlet velocity which by design prevents unnecessary jamming of the cutter mechanism and minimizes blinding of the pump by large objects that block the inlet shroud.
 4. The impeller mechanism must rotate at a nominal speed of no greater than 1800 rpm.
- C. The grinder shall be capable of reducing all components in normal domestic sewage, including a reasonable amount of "foreign objects," such as paper, wood, plastic, glass, wipes, rubber and the like, to finely-divided particles which will pass freely through the passages of the pump and the 1-1/4" diameter stainless steel discharge piping.

2.03 ELECTRIC MOTOR

- A. As a maximum, the motor shall be a 1 HP, 1725 RPM, 240 Volt 60 Hertz, 1 Phase, capacitor start, ball bearing, air-cooled induction type with Class F installation, low starting current not to exceed 30 amperes and high starting torque of 8.4 foot pounds. The motor shall be press-fit into the casting for better heat transfer and longer winding life. Inherent protection against running overloads or locked rotor conditions for the pump motor shall be provided by the use of an automatic-reset, integral thermal overload protector incorporated into the motor. This motor protector combination shall have been specifically investigated and listed by Underwriters Laboratories, Inc., for the application. Non-capacitor start motors or permanent split capacitor motors will not be accepted because of their reduced starting torque and consequent diminished grinding capability. The wet portion of the motor armature must be 300 Series stainless. Oil-filled motors shall not be accepted.

2.04 MECHANICAL SEAL

- A. The pump/core shall be provided with a mechanical shaft seal to prevent leakage between the motor and pump. The seal shall have a stationary ceramic seat and carbon rotating surface with faces precision lapped and held in position by a stainless steel spring.

2.05 TANK

2.05.01 HDPE Tank

- A. High Density Polyethylene (HDPE) construction. The tank shall be a wetwell design made of high density polyethylene of a grade selected for environmental stress cracking resistance. Corrugated sections are to be made of a double wall construction with the internal wall being generally smooth to promote scouring. Corrugations of the outside wall are to be of a minimum amplitude of 1-1/2" to provide necessary transverse stiffness. Any incidental sections of a single wall construction are to be a minimum .250 inch thick. All seams created during tank construction are to be thermally welded and factory tested for leak tightness. Tank wall and bottom must withstand the pressure exerted by saturated soil loading at maximum burial depth. All station components must function normally when exposed to maximum external soil and hydrostatic pressure.
- B. The tank shall be furnished with a factory installed PVC inlet flange to accept a 4.50" OD (4" DWV or SCH 40) inlet pipe.
- C. The tank shall include a lockable cover assembly providing low profile mounting and watertight capability. The cover shall be high density polyethylene or fiberglass, green in color, with a load rating of 150 lbs per square foot. The cover assembly shall also include an integral 2-inch vent to prevent sewage gases from accumulating in the tank. The accessway design and construction shall

facilitate field adjustment of station height in increments of 3" or less without the use of any adhesives or sealants requiring cure time before installation can be completed.

- D. The power and control cable shall connect to the pump by means of the provided NEMA 6P Electrical Quick Disconnect (EQD) and shall enter the tank through a factory installed watertight strain relief connector. An electrical junction box shall not be permitted in the tank.
- E. The station shall have all necessary penetrations factory sealed and tested. No field penetrations shall be acceptable.

2.05.02 Fiberglass Tank

- A. **Fiberglass Construction.** The tank shall be a wetwell design consisting of a single wall, laminated fiberglass construction. The resin used shall be of a commercial grade suitable for the environment. The reinforcing material shall be a commercial grade of glass fiber capable of bonding with the selected resin. The inner surface shall have a smooth finish and be free of cracks and crazing. The exterior tank surface shall be relatively smooth with no exposed fiber or sharp projections present.
- B. The tank wall and bottom shall be of sufficient thickness and construction to withstand the imposed loading due to saturated soil at the specified burial depth for each available tank height. All station components must function normally when exposed to the external soil and hydrostatic pressures developed at the specified burial depth. The tank bottom shall be reinforced with a fiberglass plate extending beyond the tank walls to support concrete anchoring, as required, to prevent flotation.
- C. The Fiberglass tank shall have a stainless steel discharge bulkhead which terminates outside the tank wall with a 1-1/4" female pipe thread. The discharge bulkhead shall be factory installed and warranted by the manufacturer to be watertight. The tank shall be furnished with a field installed EPDM grommet to accept a 4.50" OD (4" DWV or SCH 40) inlet pipe.
- D. The power and control cable shall connect to the pump by means of the provided NEMA 6P Electrical Quick Disconnect (EQD) and shall enter the tank through a field installed watertight strain relief connector supplied by the manufacturer. An electrical junction box shall not be permitted in the tank. Installation of the inlet grommet and cable strain relief shall require field penetration of the tank wall by the installing party. The tank shall also be vented to prevent sewage gases from accumulating inside the tank by means of a factory-provided, field-installed mushroom vent. The station cover shall be factory drilled to accept the mushroom vent. The tank and stainless steel discharge bulkhead shall be factory-tested to be watertight.

2.06 DISCHARGE HOSE AND DISCONNECT/VALVE

- A. **Discharge Hose and Disconnect/Valve:** All discharge fittings and piping shall be constructed of polypropylene, EPDM or PVC. The discharge hose assembly shall include a shut-off valve rated for 200 psi WOG and a quick disconnect feature to simplify installation and pump removal. The bulkhead penetration shall be factory installed and warranted by the manufacturer to be watertight.

2.07 ELECTRICAL QUICK DISCONNECT

- A. The grinder pump core shall include a factory-installed NEMA 6P electrical quick disconnect (EQD) for all power and control functions. The EQD will be supplied with 32', 25' of useable, electrical supply cable (ESC) to connect to the alarm panel. The EQD shall require no tools for assembly, seal against water before the electrical connection is made, and include radial seals to assure a watertight seal regardless of tightening torque. Plug-type connections of the power cable onto the pump housing will not be acceptable due to the potential for leaks and electrical shorts.

Junction boxes are not acceptable due to the large number of potential leak points. The EQD shall be so designed to be conducive to field wiring as required.

2.08 CHECK VALVE

- A. The pump discharge shall be equipped with a factory installed, gravity operated, flapper-type integral check valve built into the discharge piping. The check valve will provide a full-ported passageway when open, and shall introduce a friction loss of less than 6 inches of water at maximum rated flow. Moving parts will be made of a 300 Series stainless steel and fabric reinforced synthetic elastomer to ensure corrosion resistance, dimensional stability, and fatigue strength. A nonmetallic hinge shall be an integral part of the flapper assembly providing a maximum degree of freedom to assure seating even at a very low back-pressure. The valve body shall be an injection molded part made of an engineered thermoplastic resin. The valve shall be rated for continuous operating pressure of 235 psi. Ball-type check valves are unacceptable due to their limited sealing capacity in slurry applications.

2.09 ANTI-SIPHON VALVE

- A. Anti-Siphon Valve: The pump discharge shall be equipped with a factory-installed, gravity-operated, flapper-type integral anti-siphon valve built into the discharge piping. Moving parts will be made of 300 Series stainless steel and fabric-reinforced synthetic elastomer to ensure corrosion resistance, dimensional stability, and fatigue strength. A nonmetallic hinge shall be an integral part of the flapper assembly, providing a maximum degree of freedom to ensure proper operation even at a very low pressure. The valve body shall be injection-molded from an engineered thermoplastic resin. Holes or ports in the discharge piping are not acceptable anti-siphon devices due to their tendency to clog from the solids in the slurry being pumped. The anti-siphon port diameter shall be no less than 60% of the inside diameter of the pump discharge piping.

2.10 CORE UNIT

- A. Core Unit: The grinder pump station shall have an easily removable core assembly containing pump, motor, grinder, all motor controls, check valve, anti-siphon valve, electrical quick disconnect and wiring. The watertight integrity of the core unit shall be established by a 100% factory test at a minimum of 5 PSIG.

2.11 CONTROLS

- A. All necessary motor starting controls shall be located in the cast iron enclosure of the core unit secured by stainless steel fasteners. Locating motor starting controls in a plastic enclosure is not acceptable. Wastewater level sensing controls shall be housed in a separate enclosure from motor starting controls. Level sensor housing must be sealed via a radial type seal; solvents or glues are not acceptable. Level sensing control housing must be integrally attached to pump assembly so that it may be removed from the station with the pump and in such a way as to minimize the potential for the accumulation of grease and debris accumulation, etc. Level sensing housing must be a high-impact thermoplastic copolymer over-molded with a thermo plastic elastomer. The use of PVC for the level sensing housing is not acceptable.
- B. Non-fouling wastewater level controls for controlling pump operation shall be accomplished by monitoring the pressure changes in an integral air column connected to a pressure switch. The air column shall be integrally molded from a thermoplastic elastomer suitable for use in wastewater and with excellent impact resistance. The air column shall have only a single connection between the water level being monitored and the pressure switch. Any connections are to be radial sealed with redundant O-rings. The level detection device shall have no moving parts in direct contact with the wastewater and shall be integral to the pump core assembly in a single, readily-exchanged unit. Depressing the push to run button must operate the pump even with the level sensor housing removed from the pump.

- C. All fasteners throughout the assembly shall be 300 Series stainless steel. High-level sensing will be accomplished in the manner detailed above by a separate air column sensor and pressure switch of the same type. Closure of the high-level sensing device will energize an alarm circuit as well as a redundant pump-on circuit. For increased reliability, pump ON/OFF and high-level alarm functions shall not be controlled by the same switch. Float switches of any kind, including float trees, will not be accepted due to the periodic need to maintain (rinsing, cleaning) such devices and their tendency to malfunction because of incorrect wiring, tangling, grease buildup, and mechanical cord fatigue. To assure reliable operation of the pressure switches, each core shall be equipped with a factory installed equalizer diaphragm that compensates for any atmospheric pressure or temperature changes. Tube or piping runs outside of the station tank or into tank-mounted junction boxes providing pressure switch equalization will not be permitted due to their susceptibility to condensation, kinking, pinching, and insect infestation. The grinder pump will be furnished with a 6 conductor 14 gauge, type SJOW cable, pre-wired and watertight to meet UL requirements with a factory installed NEMA 6P EQD half attached to it.

2.12 ALARM PANEL

- A. Each grinder pump station shall include a NEMA 4X, UL-listed alarm panel suitable for wall or pole mounting. The NEMA 4X enclosure shall be manufactured of thermoplastic polyester to ensure corrosion resistance. The enclosure shall include a hinged, lockable cover with padlock, preventing access to electrical components, and creating a secured safety front to allow access only to authorized personnel. The enclosure shall not exceed 10.5" W x 14" H x 7" D, or 12.5" W x 16" H x 7.5" D if certain options are included.
- B. The alarm panel shall contain one 15-amp, double-pole circuit breaker for the pump core's power circuit and one 15-amp single-pole circuit breaker for the alarm circuit. The panel shall contain a push-to-run feature, an internal run indicator, and a complete alarm circuit. All circuit boards in the alarm panel are to be protected with a conformal coating on both sides and the AC power circuit shall include an auto resetting fuse.
- C. The alarm panel shall include the following features: external audible and visual alarm; push-to-run switch; push-to-silence switch; redundant pump start; and high level alarm capability. The alarm sequence is to be as follows when the pump and alarm breakers are on:
1. When liquid level in the sewage wet-well rises above the alarm level, the contacts on the alarm pressure switch activate, audible and visual alarms are activated, and the redundant pump starting system is energized.
 2. The audible alarm may be silenced by means of the externally mounted, push-to-silence button.
 3. Visual alarm remains illuminated until the sewage level in the wet-well drops below the "off" setting of the alarm pressure switch.
- D. The visual alarm lamp shall be inside a red, oblong lens at least 3.75" L x 2.38" W x 1.5" H. Visual alarm shall be mounted to the top of the enclosure in such a manner as to maintain NEMA 4X rating. The audible alarm shall be externally mounted on the bottom of the enclosure, capable of 93 dB @ 2 feet. The audible alarm shall be capable of being deactivated by depressing a push-type switch that is encapsulated in a weatherproof silicone boot and mounted on the bottom of the enclosure (push-to-silence button).
- E. The entire alarm panel, as manufactured and including any of the following options shall be listed by Underwriters Laboratories, Inc.
- F. Sentry Simplex Protect - Provide protection from the following operating conditions:

1. **Low Voltage (Brownout) Protection** – A lockout cycle will prevent the motor from operating and will illuminate an LED if:
 - the incoming AC Mains voltage drops below a predetermined minimum, typically 12% of nameplate (211 volts for a 240 volt system) for 2 to 3 seconds, regardless of whether the motor is running
 - the lockout cycle will end if the incoming AC Mains voltage returns to a predetermined value, typically 10% of nameplate (216 volts for a 240 volt system)

The system continues to retest the voltage every second indefinitely. If the lockout cycle has been initiated and the voltage comes back above the predetermined starting voltage, the system will function normally. The LED remains illuminated during a Brownout condition and remains latched until the pump breaker is turned off and then on again (reset). The audible and visual alarm will not be activated unless there is a high wastewater level in the tank.
2. **Run Dry Protection** – A 20-minute lockout cycle will prevent the motor from operating and will illuminate an LED when the wastewater level in the tank is below the pump inlet level. The condition is rechecked every 20 minutes. If the lockout cycle has been initiated and the condition is satisfied, the pump is not allowed to cycle normally but the LED remains latched. The LED will remain latched until the pump breaker is turned off and then on again (reset). If the condition is not satisfied after 3 consecutive attempts, the visual alarm will be activated until the pump breaker is turned off and on (reset) or until there is one cycle of normal operation. If a high level condition is presented at any time, a pump run cycle will be activated.
3. **High System Pressure Protection** – A 20-minute lockout cycle will prevent the motor from operating and will illuminate an LED when the pressure in the discharge line is atypically high (closed valve or abnormal line plug). The condition is rechecked every 20 minutes. If the condition is satisfied, the pump is allowed to cycle normally but the LED remains latched. If the condition is not satisfied after 3 consecutive attempts, the pump is locked out indefinitely until the condition is removed and power is reset. The LED will remain latched until the pump breaker is turned off and then on again (reset). The audible and visual alarm will be activated.
4. In all of the above cases, if more than one error condition is presented, the LED depicting the most recent error condition will be displayed.
5. Include these following features:
 - a) Alarm Activated Dry Contacts – Normally open relay contact closes upon alarm activation.
 - b) Alarm Activated Contacts for Remote Indoor Alarm Module – Will work with or without power to the alarm panel and is designed to work with E/One’s Remote Sentry.
 - c) Includes Inner Door Dead Front
 - d) Separate LED’s for each condition

2.13 DUPLEX STATIONS

- A. Duplex station shall be model T260 DUPLEX manufactured by Environment One Corporation:

- B. Each grinder pump station shall include a NEMA 4X, UL-listed alarm panel suitable for wall or pole mounting. The NEMA 4X enclosure shall be manufactured of thermoplastic to ensure corrosion resistance. The enclosure shall include a hinged, lockable cover with padlock, preventing access to electrical components, and creating a secured safety front to allow access only to authorized personnel. The standard enclosure shall not exceed 12.5" W x 16" H x 7.5" D.
- C. The panel shall contain one 15-amp single pole circuit breaker for the alarm circuit and one 15-amp double pole circuit breaker per core for the power circuit. The panel shall contain a push-to-run feature, an internal run indicator, and a complete alarm circuit. All circuit boards in the alarm panel are to be protected with a conformal coating on both sides and the AC power circuit shall include an auto resetting fuse.
- D. The visual alarm lamp shall be inside a red, oblong lens at least 3.75" L x 2.38" W x 1.5" H. Visual alarm shall be mounted to the top of the enclosure in such a manner as to maintain NEMA 4X rating. The audible alarm shall be externally mounted on the bottom of the enclosure, capable of 93 dB @ 2 feet. The audible alarm shall be capable of being deactivated by depressing a push-type switch that is encapsulated in a weatherproof silicone boot and mounted on the bottom of the enclosure (push-to-silence button).

The high-level alarm system shall operate as follows:

1. The panel will go into alarm mode if either pump's alarm switch closes. During the initial alarm mode both pumps will run and the alarm light and buzzer will be delayed for a period of time based on user settings (default is 3-1/2 minutes). If the station is still in high-level alarm after the delay, the light and buzzer will be activated.
2. The audible alarm may be silenced by means of the externally mounted push-to-silence button.
3. The visual alarm remains illuminated until the sewage level in the wet well drops below the "off" setting of the alarm switch for both pumps.

The entire alarm panel, as manufactured and including any of the following options shall be listed by Underwriters Laboratories, Inc.

2.14 SERVICEABILITY

- A. The grinder pump core, including level sensor assembly, shall have two lifting hooks complete with lift-out harness connected to its top housing to facilitate easy core removal when necessary. The level sensor assembly must be easily removed from the pump assembly for service or replacement. All mechanical and electrical connections must provide easy disconnect capability for core unit removal and installation. Each EQD half must include a water-tight cover to protect the internal electrical pins while the EQD is unplugged. A pump push-to-run feature will be provided for field trouble shooting. The push-to-run feature must operate the pump even if the level sensor assembly has been removed from the pump assembly. All motor control components shall be mounted on a readily replaceable bracket for ease of field service.

2.15 OSHA CONFINED SPACE

- A. All maintenance tasks for the grinder pump station must be possible without entry into the grinder pump station (as per OSHA 1910.146 Permit-required confined spaces). *“Entry means the action by which a person passes through an opening into a permit-required confined space. Entry includes ensuing work activities in that space and is considered to have occurred as soon as any part of the entrant’s body breaks the plane of an opening into the space.”*

2.16 SAFETY

- A. The grinder pump shall be free from electrical and fire hazards as required in a residential environment. As evidence of compliance with this requirement, the completely assembled and wired grinder pump station shall be listed by Underwriters Laboratories, Inc., to be safe and appropriate for the intended use. UL listing of components of the station, or third-party testing to UL standard are not acceptable.
- B. The grinder pump shall meet accepted standards for plumbing equipment for use in or near residences, shall be free from noise, odor, or health hazards, and shall have been tested by an independent laboratory to certify its capability to perform as specified in either individual or low pressure sewer system applications. As evidence of compliance with this requirement, the grinder pump shall bear the seal of NSF International. Third-party testing to NSF standard is not acceptable.

PART 3 - EXECUTION

3.01 FACTORY TEST

- A. Each grinder pump shall be submerged and operated for 1.5 minutes (minimum). Included in this procedure will be the testing of all ancillary components such as, the anti-siphon valve, check valve, discharge assembly and each unit’s dedicated level controls and motor controls. All factory tests shall incorporate each of the above listed items. Actual appurtenances and controls which will be installed in the field shall be particular to the tested pump only. A common set of appurtenances and controls for all pumps is not acceptable. Certified test results shall be available upon request showing the operation of each grinder pump at two different points on its curve. Additional validation tests include: integral level control performance, continuity to ground and acoustic tests of the rotating components.
- B. All HDPE basins shall be factory leak tested to assure the integrity of all joints, seams and penetrations. All necessary penetrations such as inlets, discharge fittings and cable connectors shall be included in this test along with their respective sealing means (grommets, gaskets etc.). Fiberglass basins with stainless steel discharge bulkhead shall be factory tested to be watertight.

3.02 CERTIFIED SERVICE PROGRAM

- A. The grinder pump manufacturer shall provide a program implemented by the manufacturer’s personnel as described in this specification to certify the service company as an authorized serviced center. As evidence of this, the manufacturer shall provide, when requested, sufficient evidence that they have maintained their own service department for a minimum of 30 years and currently employ a minimum of five employees specifically in the service department.

- B. As part of this program, the manufacturer shall evaluate the service technicians as well as the service organization annually. The service company will be authorized by the manufacturer to make independent warranty judgments. The areas covered by the program shall include, as a minimum:
1. Pump Population Information — The service company will maintain a detailed database for the grinder pumps in the territory that tracks serial numbers by address.
 2. Inventory Management — The service company must maintain an appropriate level of inventory (pumps, tanks, panels, service parts, etc.) including regular inventory review and proper inventory labeling. Service technicians will also maintain appropriate parts inventory and spare core(s) on service vehicles.
 3. Service Personnel Certification — Service technicians will maintain their level-specific certification annually. The certifications are given in field troubleshooting, repair, and training.
 4. Service Documentation and Records — Start up sheets, service call records, and customer feedback will be recorded by the service company.
 5. Shop Organization — The service company will keep its service shop organized and pumps will be tagged with site information at all times. The shop will have all required equipment, a test tank, and cleaning tools necessary to service pumps properly.

3.03 DELIVERY

- A. All grinder pump core units, including level controls, will be delivered to the job site 100 percent completely assembled, including testing, ready for installation. Grinder pump cores will be shipped separately from the tanks. Installing the cores and discharge piping/hose into the tanks is the only assembly step required and allowed due to the workmanship issues associated with other on-site assembly. Grinder pump cores must be boxed for ease of handling.

3.04 INSTALLATION

- A. The contractor shall be responsible for any necessary sheeting and bracing.
- B. The Contractor shall be responsible for handling ground water to provide a firm, dry subgrade for the structure, and shall guard against flotation or other damage resulting from general water or flooding.
- C. Remove packing material. User instructions MUST be given to the City. Hardware supplied with the unit, if required, will be used at installation. The basin will be supplied with a standard 4" inlet grommet (4.50" OD) for connecting the incoming sewer line. Appropriate inlet piping must be used. The basin may not be dropped, rolled or laid on its side for any reason.
- D. Installation shall be accomplished so that 1" to 4" of accessway, below the bottom of the lid, extends above the finished grade line. The finished grade shall slope away from the unit. The diameter of the excavated hole must be large enough to allow for the concrete anchor.
- E. A 6" inch (minimum) layer of naturally rounded aggregate, clean and free flowing, with particle size of not less than 1/8" or more than 3/4" shall be used as bedding material under each unit.

- F. A concrete anti-flotation collar, as detailed on the drawings, and sized according to the manufacturer's instructions, shall be required and shall be pre-cast to the grinder pump or poured in place. Each grinder pump station with its pre-cast anti-flotation collar shall have a minimum of three lifting eyes for loading and unloading purposes.
- G. If the concrete is poured in place, the unit shall be leveled, and filled with water, to the bottom of the inlet, to help prevent the unit from shifting while the concrete is being poured. The concrete must be manually vibrated to ensure there are no voids. If it is necessary to pour the concrete to a level higher than the inlet piping, an 8" sleeve is required over the inlet prior to the concrete being poured.
- H. The electrical enclosure shall be furnished, installed and wired to the grinder pump station by the Contractor. An alarm device is required on every installation, there shall be no exceptions. It will be the responsibility of the Contractor to coordinate with the individual property owner(s) to determine the optimum location for the alarm panel.
- I. The Contractor shall mount the alarm device in a conspicuous location, as per national and local codes. The alarm panel will be connected to the grinder pump station by a length of 6-conductor type TC cable as shown on the contract drawings. The power and alarm circuits must be on separate power circuits. The grinder pump stations will be provided with 32', 25' of useable, electrical supply cable to connect the station to the alarm panel. This cable shall be supplied with a factory installed EQD half to connect to the mating EQD half on the core.

3.05 BACKFILL REQUIREMENTS

- A. Proper backfill is essential to the long-term reliability of any underground structure. Several methods of backfill are available to produce favorable results with different native soil conditions. The most highly recommended method of backfilling is to surround the unit to grade using Class I or Class II backfill material as defined in ASTM 2321. Class 1A and Class 1B are recommended where frost heave is a concern; Class 1B is a better choice when the native soil is sand or if a high, fluctuating water table is expected. Class 1, angular crushed stone, offers an added benefit in that it doesn't need to be compacted.
- B. Class II, naturally rounded stone, may require more compactive effort, or tamping, to achieve the proper density. If the native soil condition consists of clean compactible soil, with less than 12% fines, free of ice, rocks, roots and organic material, it may be an acceptable backfill. Soil must be compacted in lifts not to exceed one foot to reach a final Proctor Density of between 85% and 90%. Heavy, non-compactible clays and silts are not suitable backfill for this or any underground structure such as inlet or discharge lines.
- C. Another option is the use of a flowable fill (i.e., low slump concrete). This is particularly attractive when installing grinder pump stations in augured holes where tight clearances make it difficult to assure proper backfilling and compaction with dry materials. Flowable fills should not be dropped more than four feet from the discharge to the bottom of the hole to avoid separation of the constituent materials.
- D. Backfill of clean, native earth, free of rocks, roots, and foreign objects, shall be thoroughly compacted in lifts not exceeding 12" to a final Proctor Density of not less than 85%. Improper backfilling may result in damaged accessways. The grinder pump station shall be installed at a minimum depth from grade to the top of the 1 1/4" discharge line, to assure maximum frost

protection. The finish grade line shall be 1" to 4" below the bottom of the lid, and final grade shall slope away from the grinder pump station.

- E. All restoration will be the responsibility of the Contractor. The properties shall be restored to their original condition in all respects, including, but not limited to streets, drives, curb, sidewalk, landscaping, etc.

3.06 START-UP AND FIELD TESTING

- A. The manufacturer shall provide the services of qualified factory trained technician(s) who shall inspect the placement and wiring of each station, perform field tests as specified herein, and instruct the City or Owner's personnel in the operation and maintenance of the equipment before the stations are accepted by the City or Owner.
- B. All equipment and materials necessary to perform testing shall be the responsibility of the Contractor. This includes, as a minimum, a portable generator and power cable (if temporary power is required), water in each basin (filled to a depth sufficient to verify the high level alarm is operating), and opening of all valves in the system. These steps shall be completed prior to the qualified factory trained technician(s) arrival on site.
- C. The services of a trained, factory-authorized technician shall be provided at a rate of 40 hours for every 100 grinder pump stations supplied.
- D. Upon completion of the installation, the authorized factory technician(s) will perform the following test on each station:
 - 1. Make certain the discharge shut-off valve in the station is fully open.
 - 2. Turn ON the alarm power circuit and verify the alarm is functioning properly.
 - 3. Turn ON the pump power circuit. Initiate the pump operation to verify automatic "on/off" controls are operative. The pump should immediately turn ON.
 - 4. Consult the Manufacturer's Service Manual for detailed start-up procedures.
- E. Supply three copies of operation and maintenance manuals to the City or Owner.

END OF SECTION 3501

SECTION 3600**CAST-IN-PLACE CONCRETE****PART 1 - GENERAL****1.01 WORK INCLUDED**

- A. This section covers cast-in-place concrete materials, reinforcing steel, forms, and finishing in conjunction with water and sewer construction.
- B. Use Class B Concrete for all structures.
- C. Use Class A Concrete for bedding and blocking only.

1.02 RELATED WORK

- A. Section 2300 – Excavation, Backfilling, and Compacting
- B. Section 3100 – Installation of Sewer Pipe, Fittings, and Materials
- C. Section 3200 – Installation of Sewer Service Lines
- D. Section 3300 – Manholes
- E. Section 4100 – Installation of Water Lines and Service Lines
- F. Section 6000 - Pavement Repair

1.03 QUALITY ASSURANCE

- A. Not used.

1.04 SUBMITTALS

- A. Submit mix design, equipment details, and vendor name for field batched concrete.

1.05 REFERENCES

- A. Not used.

PART 2 - PRODUCTS**2.01 CONCRETE**

- A. Concrete: composed of Portland Cement; fine and coarse aggregate; water; and, an air entraining agent. Provide either Class A concrete or Class B concrete as described below.
- B. For Class A and Class B concrete use ready-mixed concrete; conform to ASTM C 94, latest edition; deliver and place within one hour after all materials have been placed in the mixing drum.
- C. The concrete mix shall be designed so that the proportions will produce results that will meet the requirements of Class A or Class B concrete. Proportion components, except water, by weight. Water may be measured by volume. One sack of Portland Cement consists of one cubic foot or 94 pounds. Proportion components to meet these requirements:

1. Class A Concrete:
 - a. Maximum net water/cement ratio = 0.49
 - b. Slump range: 1 - 4 inches
 - c. Minimum 28 day compressive strength: 3,000 PSI
2. Class B Concrete:
 - a. Maximum net water/cement ratio = 0.49
 - b. Slump range: 1 - 4 inches
 - c. Minimum 28 day compressive strength: 4,000 PSI
 - d. Air Content: 4 - 7
- D. Before beginning any concrete work, the Contractor shall have the concrete mix designed and the ingredients selected and proportioned by an approved independent testing laboratory meeting the requirements of ASTM E 329. Certified copies of all laboratory trial mix reports shall be sent to the Engineer from the testing laboratory for review. Do not place concrete prior to the Engineer's review and acceptance in writing of the concrete mix design.
- E. Cement: Portland Cement conforming to AASHTO M 85, Type I. Use Type III cement (high early strength) only if approved by the Engineer.
- F. Fly ash: Fly ash may be used as a partial cement replacement not exceeding 10% by weight of the cement when approved by the City. When fly ash is used, the total weight of both cement and fly ash will be used in design calculations.
- G. Water: potable water free from injurious amounts of acids, alkalis, oils, sewage, vegetable matter and dirt.
- H. Air entraining agent: use in all Class B concrete as required; conform to AASHTO M 154; add to the mixing water in solution; proportion to provide four (4) to seven (7) percent air in the concrete.
- I. Fine aggregate: clean, hard, durable particles of natural sand free from injurious amounts of organic impurities; conform to the gradation requirements of AASHTO T 27.
- J. Coarse aggregate: clean, hard and durable crushed stone or washed gravel; reasonably well graded from course to fine; per AASHTO T 27.

2.02 REINFORCING STEEL

- A. Steel bars: deformed, conforming to ASTM A 615 or A 617.
- B. Steel wire: conform to ASTM A 82, Cold-Drawn Steel Wire for Concrete Reinforcement.
- C. Wire mesh: conform to ASTM A 185; gauge and mesh per plans.
- D. Submit reinforcing steel bars shop drawings for approval.
- E. All steel reinforcement: free from rust, scale, mortar, dirt, or other objectionable coatings.

PART 3 - EXECUTION

- A. Perform excavation per Section 2300 - Excavation, Backfilling, and Compacting.
- B. Build forms neat, square, and flat so concrete will have smooth finish when forms are pulled. Construct forms to provide finished concrete to dimensions shown on plans.
- C. Place reinforcing steel accurately in accordance with details shown on the plans and properly secure in position.
- D. Concrete shall not be placed when the temperature is below 40° F and dropping or below 35° F if the temperature is rising, unless approved by the Engineer.
- E. Vibrate all structural concrete as it is placed using internal vibrators capable of transmitting vibration to the concrete at frequencies not less than 4,500 impulses per minute. Do not use form vibrators. Limit vibration to provide satisfactory consolidation without causing segregation. Do not insert vibrator more than six (6) inches into the lower courses previously vibrated. Use vibrators in a substantially vertical position; insert at uniformly spaced points no farther apart than the visible effectiveness of the vibrator.
- F. Allow concrete to cure for at least 48 hours before stripping forms. If concrete is in a structural member, do not remove forms until the concrete can withstand safely all superimposed loads.
- G. On all exposed surfaces, remove all fins and projections so the surface is smooth. Cut out and fill with grout any honeycombed areas. Extensive honeycombing is not allowable.
- H. All concrete shall be properly protected from too rapid curing or from freezing while green. If the weather is hot or dry, all freshly placed concrete shall be covered with a matting or other suitable material and kept moist for at least ten (10) days after pouring, or an approved curing compound may be used with the approval of the Public Works Director.

END OF SECTION 3600

SECTION 4000**WATER PIPE, FITTINGS, AND MATERIALS**

PART 1 - GENERAL

1.01 WORK INCLUDED

- A. This section covers the manufacture, transportation, and storage of pipe, pipe joints, fire hydrants, fittings, and other materials for water lines and service lines.
- B. Use only materials approved by the City of Bryant.

1.02 RELATED WORK

- A. Section 3600 – Cast-In-Place Concrete
- B. Section 4100 – Installation of Water Pipe, Fittings, and Materials
- C. Section 5300 - Inspection and Testing of Water Lines and Service Lines

1.03 SUBMITTALS

- A. Use of materials other than those specifically listed below is prohibited.
- B. Submit the manufacturer's certificate that the materials meet with these Specification requirements including material testing requirements.

1.04 LEAD-FREE BRASS

- A. **All brass shall be manufactured in accordance with the Safe Drinking Water Act as amended to be LEAD-FREE brass (< 0.25% Pb).**

PART 2 - PRODUCTS

2.01 POLYVINYL CHLORIDE (PVC) PIPE FOR WATER LINES

- A. PVC pipe less than 4 inches in size shall be manufactured in accordance with ASTM D-2241 and shall be SDR 13.5.
- B. PVC pipe 4 inches through 8 inches in size shall be manufactured in accordance with AWWA C900, latest revision, and shall be DR 14.
- C. PVC pipe, couplings, and fabricated fittings shall be made from virgin PVC resin that has been compounded to provide physical and chemical properties that equal or exceed cell class 12454 as defined in ASTM D1784, latest revision. Clean, reworked material generated from the manufacturer's own production shall be acceptable as long as the pipe produced meets all the requirements of the Specifications.
- D. Pipe shall have push-on rubber gasketed joints designed in accordance with ASTM D3139 and rubber gaskets complying with ASTM F-477.
- E. Nominal laying length shall be 20 feet. **Minimum length of a cut section of pipe shall be 5 feet.**
- F. Marking on pipe and shall include the following and shall be applied at intervals of not more than 5 feet.

1. Nominal size in inches and OD base (for example, 8 PVC).
2. PVC.
3. Dimension ratio (for example, DR 14).
4. AWWA designation number for this standard (ANSI/AWWA C900, or ASTM D-2241).
5. Manufacturer's name or trademark and production run record or lot code.

2.02 DUCTILE IRON PIPE FOR WATER LINES

- A. Ductile Iron Pipe shall conform to the requirements of "Ductile-Iron Pipe, Centrifugally Cast" AWWA Standard C151/A21.51, latest revision.
- B. Ductile iron pipe shall be designed in accordance with the requirements of "Thickness Design of Ductile-Iron Pipe", ANSI/AWWA C150/A21.50, latest revision. Minimum pressure class shall be 250 psi.
- C. Joint connections, pipe and fittings (latest revision):
 1. Push on and mechanical rubber gasket joints: ANSI/AWWA C111/A21.11.
 2. Flanged: ANSI/AWWA C115/A21.15, ANSI B16.1.
 3. Grooved and shouldered ANSI/AWWA C606.
- D. Nominal laying length shall be 20 feet. **Minimum length of a cut section of pipe shall be 5 feet.**
- E. Weights and Marking: Weights of pipe and fittings shall conform strictly to the requirements of ANSI Specifications. The weight, class or nominal thickness, and casting period shall be shown on each pipe. The manufacturer's mark, country where cast, year in which the pipe was produced, and the letters "DI" or "DUCTILE" shall be cast or metal stamped on the pipe, and letters and numerals on pipe sizes 14 in. (356 mm) and larger shall be not less than 1/2 in. (13 mm) in height.
- F. Corrosion Control
 1. Outside coating shall be an asphaltic coating approximately 1 mil thick. The coating shall be applied to the outside of all pipe.
 2. The interior lining for use under normal conditions shall be a cement- mortar lining and seal coat in accordance with the latest revision of ANSI/AWWA C104/A21.4, latest revision and NSF 61.
 3. Polyethylene wrap in tube or sheet form conforming to the requirements of ANSI/AWWA C105/A21.5, latest revision.

2.03 POLYETHYLENE (PE) PRESSURE PIPE AND TUBING

- A. PE pipe 3/4 inches through 2 inches in size shall be manufactured in accordance with AWWA C901, latest revision, and shall be SDR 9. Color shall be black.
- B. PE pipe shall be made from virgin PE material compounds that meet ASTM D3350 requirements. The pipe shall have a standard designation code of PE3608. Clean, reworked material generated

from the manufacturer's own production shall be acceptable as long as the pipe produced meets all the requirements of the Specifications.

- C. Marking on pipe and tubing shall include the following and shall be applied at intervals of not more than 5 ft.
1. Nominal size and diameter base (e.g., ID, OD, IPS, or CTS).
 2. SIDR, SDR, or minimum wall thickness.
 3. The manufacturer's name or trademark.
 4. The material designation code (e.g., PE 3608)
 5. The AWWA pressure class (e.g., PC 200)
 6. The AWWA designation number for this standard (e.g., AWWA C901).
 7. The manufacturer's production (lot) code that includes information such as resin source, manufacturing location, extrusion outlet (line), and manufacturing date.
 8. If not included in the manufacturer's production code, the manufacturing date, including day, month, and year in a recognized standard format. The date format should be readily recognized as a date.
 9. The seal or mark of the testing agency that certifies the material.

2.04 STAINLESS STEEL INSERTS FOR POLYETHEYLENE TUBING

- A. Inserts for PE tubing shall be solid tubular 304 stainless steel, dimpled, and flanged to retain placement within PE tubing. Inserts shall be used on all PE tubing connections. The SS steel inserts shall be specifically sized (diameter and length) for the PE tubing that is being used with.

2.05 POLYETHYLENE ENCASEMENT (PIPE WRAP)

- A. Polyethylene encasement shall be in conformance to ANSI/AWWA C105/A21.5, latest revision. The virgin linear low-density polyethylene film shall have a minimum normal thickness of .008 inches (8 mils), and shall be provided in either flat tube or sheet form.
- B. The color shall be black with nominal 2% carbon black UV inhibitor and printed per the AWWA C105 standard.
- C. Tape for field taping of polywrapped pipe, fittings, etc. or field repair of missing polyethylene encasement material shall be Polyken #900, Scotchrap #50 or equal, at least 2-inches wide, and installed as per the Polyethylene Encasement Installation Guide published by DIPRA. Duct Tape is not permitted.
- D. All buried iron pipe, valves, and fittings shall be double wrapped.

2.06 DUCTILE IRON FITTINGS

- A. All ductile iron fittings shall conform to the requirements of ANSI/AWWA C153/A21.53, latest revision, for Ductile Iron Compact Fittings. All fittings shall be MJ x MJ.
- B. Solid sleeves shall be long bodied only.

2.07 FOSTER ADAPTERS

- A. Compact MJ restraints shall be Foster Adapter by Infact Corporation.

2.08 SWIVEL ADAPTERS AND HYDRANT TEES

- A. Swivel adapters and hydrant tees shall be designed for a working pressure of at least 250-psi and to fit standard mechanical joint fittings (AWWA C111). One end of the swivel adapter and the branch of the hydrant tee shall be provided with a gland that may be rotated 360 degrees on the fitting. Lengths of swivel adapters shall be as specified.

2.09 MECHANICAL JOINT RETAINER GLANDS

- A. Restraint devices for mechanical joint fittings and appurtenances for nominal pipe sizes 3-inch through 48-inch shall consist of multiple gripping wedges incorporated into a follower gland meeting the applicable requirements of ANSI/AWWA C110/A21.10.
- B. Mechanical joint retainer glands shall be made from ductile iron and shall be designed for a working pressure of at least 350-psi for 3-inch through 16-inch ductile iron pipe, at least 305-psi for 3-inch through 12-inch PVC, and at least 250-psi for 18-inch through 48-inch ductile iron pipe. Buried pipe mechanical joints shall comply with AWWA C153 and AWWA C111.
- C. Retainer glands shall have an approved coating system for corrosion resistance equivalent to MEGA-BOND® and manufacturing traceability. Retainer glands shall be manufactured by EBAA Iron.

2.10 PIPE RESTRAINTS

- A. Devices for the prevention of “over-insertion” of AWWA C900 PVC sizes 4-inch through 12-inch shall be Series 5000 MEGA-STOP Bell Protection System, as manufactured by EBAA Iron, Inc. Devices shall have an approved coating system for corrosion resistance equivalent to MEGA-BOND® and manufacturing traceability.
- B. Bell restraints for AWWA C900 PVC sizes 4-inch through 12-inch shall be Series 1900 Restraint Harness, as manufactured by EBAA Iron, Inc. Devices shall have an approved coating system for corrosion resistance equivalent to MEGA-BOND® and manufacturing traceability.
- C. Bell restraints for Ductile Iron Pipe sizes 4-inch through 48-inch shall be Series 1700 Restraint Harness, as manufactured by EBAA Iron, Inc. Devices shall have an approved coating system for corrosion resistance equivalent to MEGA-BOND® and manufacturing traceability.
- D. When all-thread attachments are required, **eye-bolt style attachments are not permitted**. Romac “Ductile Lug” style attachments or approved equal shall be used. All-threads shall be made of 316 stainless steel.

2.11 RESTRAINED FLANGED COUPLING ADAPTERS

- A. Flanged coupling adapters used to transition from plain end pipe to a flanged fitting, above ground, shall be EBAA Iron Series 2100 Megaflange or Smith-Blair 911 or 920.
- B. Pressure rating shall be a minimum of 200 psi.

2.12 RESTRAINED COUPLINGS

- A. Restrained couplings to connect two pieces of pipe, size on size, shall be EBAA Iron Series 3800 Restrained Coupling or Smith-Blair 471, 472, or 473.

- B. Pressure rating shall be a minimum of 200 psi.

2.13 BOLTS AND NUTS

- A. All bolts and nuts for valves, fittings, and restraints shall be 316 stainless steel unless otherwise indicated. Anti-seize lubricant shall be used when assembling all stainless steel hardware to reduce galling.

2.14 GATE VALVES

- A. Gate valves 2-inch through 12-inch nominal pipe size shall be resilient-seated type, non-rising stem gate valves, in conformance with the requirements of AWWA C509 or AWWA C515, latest revision.
- B. Gate valves shall be Made in USA and shall be Mueller Series 2360, American Flow Control Series 2500, or American AVK Company Series 25 or Series 45.
- C. All gate valves shall be designed for a minimum of 200 psi working pressure. All gate valves shall have 304 stainless steel bolts.
- D. All gate valves shall have O-ring stem seals. The O-ring stem seal shall be so designed that the seal above the stem collar can be replaced with the valve under pressure in the full-open position.
- E. Gate valves shall have standard mechanical joint ends unless otherwise indicated on the Drawings.
- F. Buried gate valves shall be designed for operation with a nominal 2-inch square operating nut. The standard direction of opening shall be open left as viewed from the top.
- G. Handwheels for gate valves shall be in conformance to AWWA C515, latest revision.
- H. The interior and exterior of the valve body and bonnet shall have factory applied fusion bonded epoxy coating meeting AWWA C550, latest revision.
- I. Valves shall be tested in accordance with AWWA C515, latest revision.
- J. Markings shall be cast on the bonnet or body, or stamped on a permanently affixed corrosion-resistant tag of each valve.
 1. Manufacturer's name or mark.
 2. Year the valve casting was made.
 3. Size of the valve.
 4. Letters C509 or C515
 5. Working water pressure (e.g. 250W)

2.15 BUTTERFLY VALVES

- A. Butterfly valves 14-inch and larger shall conform with the requirements of AWWA C504, latest revision, for Rubber-Seated Butterfly Valves.
- B. Butterfly valves shall be Pratt HP250II or Dezurik BAW.

- C. Butterfly valves shall be designed for a minimum of 250 psi working pressure. Butterfly valves shall have 304 stainless steel bolts.
- D. Butterfly valves shall be of the tight closing, synthetic rubber-seat type, as follows.
 - 1. Valves 20 inches (nominal diameter) and smaller shall have bonded seats which are simultaneously molded in, vulcanized and bonded to the body. Seat bond must withstand 75 pounds pull under test procedure ASTM D429, Method B.
 - 2. On valves 24 inches and larger, all seats shall be of a synthetic rubber compound. Seats shall be retained in the valve body by mechanical means without retaining rings, segments, screws or hardware of any kind in the flow stream. Seats shall be a full 360° without interruption and have a plurality of grooves mating with a spherical disc edge seating surface. Valve seats shall be field adjustable around the full 360° circumference and replaceable without dismantling operator, disc or shaft and without removing the valve from the line.
- E. Valve discs shall utilize an on-center shaft and symmetrical design and be cast from Ductile Iron ASTM A536 Gr. 65-45-12. The disc edge shall be stainless steel type 316.
- F. Butterfly valves shall have standard mechanical joint ends unless otherwise indicated on the Drawings.
- G. Buried butterfly valves shall be designed for operation with a nominal 2-inch square operating nut. The standard direction of opening shall be open left as viewed from the top. The valve shaft shall be constructed of stainless steel and the bearings shall be corrosion resistant and self-lubricating. The valves shall be equipped with a totally enclosed type operator, fully gasketed and grease packed, suitable for direct burial.
- H. The interior and exterior of the valve body and bonnet shall have factory applied epoxy coating system meeting AWWA C550, latest revision.
- I. Valves shall be tested in accordance with AWWA C504, latest revision.
- J. Markings shall be cast on the bonnet or body, or stamped on a permanently affixed corrosion-resistant tag of each valve.
 - 1. Manufacturer's name or mark.
 - 2. Year the valve casting was made.
 - 3. Size of the valve.
 - 4. Class (e.g. 250B)

2.16 BALL VALVES

- A. Ball valves shall be Made in USA, and shall be Ford B11-777-NL or James Jones E1900, with "tee-head" style operating nut.

2.17 VALVE BOXES

- A. Valve boxes shall be Made in USA, and shall be East Jordan Iron Works 8550 Series or Tyler Union 6850 Series, screw type, and shall be of correct length to match the bury of the main.

- B. The valve box and appurtenances shall include a base and a top section with a drop lid. The lid shall be marked with the word "WATER". All lids shall have a concrete pad with a minimum of 18 inches square or round dimension as appropriate.
- C. Lids on valves on fire lines shall be marked with the word "FIRE".
- D. Markings shall be cast on each part:
 - 1. Manufacturer's name or mark.
 - 2. Model number
 - 3. Year the casting was made.
 - 4. Material of construction
 - 5. USA
- E. A valve box alignment device shall be provided and installed for each valve box installation. The device shall be of HDPE or Glass Filled Polypropylene construction. It shall be furnished in two pieces that will lock together under the operating nut of the valve without requiring the removal of the operating nut. The device shall not affect the operation of the valve. The device shall be AFC Alignment Ring as manufactured by American Flow Control.

2.18 OPERATING NUT EXTENSIONS

- A. Operating nut extensions shall be used when the top of the operating nut is greater than 4 feet from the top of finished surface.
- B. The stem shall be 1" SCH40 steel pipe with a 2-inch square bar steel operating nut attached to the upper end. **The stem extension shall be of adequate length to reach from the valve operating nut to a point within 24-inches to 12-inches of the finished surface.** A box wrench, 2 1/8" I.D. square, made from steel 3/16-inches thick shall be welded to the lower end of the stem extension which will fit over the valve operating nut. Two-inch valves with a tee-head operating nut will require a rectangular shaped box wrench on the end of the valve stem extension. The extension shall be secured to the valve operating nut by two 3/8" set screws. A round center guide made from 1/8-inch or 3/16-inch steel plate shall be placed on the valve stem extension approximately 6-inches from the upper end. The diameter of the guide shall be slightly less than the inside diameter of the valve box. The guide shall be affixed to the stem extension in such a way that it can rotate freely on the stem. Welds on stem extensions (top and bottom nut) shall be 1/8" - 3/16" fillet weld around full circumference.
- C. Shop drawings shall be submitted to the City of Bryant for approval prior to installing the stem extension pieces.

2.19 FIRE HYDRANTS

- A. Fire hydrants shall be dry barrel hydrants in conformance with AWWA C502, latest revision. Fire hydrants shall be designed for a working pressure of 250 pounds per square inch gauge. Fire hydrants shall be three-way.
- B. Paint for Bryant hydrants:
 - 1. Surface preparation standard shall be SSPC-SP6/NACE 3 Commercial Blast Cleaning.

2. Fire hydrants, hydrant caps, and cap chains shall be coated with a base coat of Sherwin Williams (SW) Corothane I Mio-Aluminum B65S14.
 3. The hydrant bonnet shall be coated with SW Corothane I HS, blue in color.
 4. The Operating Nut and Hydrant Cap Nuts shall be coated with SW Corothane I HS B65T54, blue in color.
 5. Any part of the hydrant not coated with Corothane I HS shall receive a top coat of Corothane I Mio-Aluminum.
 6. All coating thicknesses shall be according to manufacturer's recommendations.
 7. The brass tag on the bonnet of the hydrant will not be painted.
- C. Permitted fire hydrants are American Flow Control 5-1/4" Waterous Pacer WB67-250, Mueller Super Centurion 250, and M&H Valve Company-Style 129 hydrants.
- D. Hydrants shall have a 6 inch mechanical joint inlet in conformance to the dimensions shown in ANSI/AWWA C110/A21.10, latest revision. Three-way hydrants shall have a 5-1/4 inch valve opening.
- E. Fire hydrants shall be equipped with a two-piece barrel with a safety stem coupling and a break-away flange at the ground line and shall be designed for a 48-inch bury.
- F. Hydrants shall be equipped with two 2-1/2 inch hose nozzles and one 4-1/2 inch pumper nozzle. The operating nut shall be a nominal 1-1/2 inch pentagon, National Standard operating nut designed to open left (counterclockwise).
- G. Hydrants shall be supplied with heavy duty, non-kinking nozzle cap chains.
- H. Fire hydrants in non-paved areas shall be installed with a 8" x 16" square, 4" thick concrete pad, reinforced with 2 layers of #5 rebar, around the lower barrel of the hydrant six inches below the bottom of the break-away flange.
- I. A fire hydrant extension shall be installed in all locations where the centerline of the pumper nozzle is less than 18-inches above the finished grade elevation. The extension shall bring the centerline of the pumper nozzle between 18-inches and 24-inches above the finished grade elevation. The centerline of the pumper nozzle shall be 24-inches above rough grade elevations where sidewalks and yards will be installed in the future, in new subdivisions only. Extensions shall be Waterous K562 or Mueller A-320, with no more than one extension allowed per hydrant.
- J. Identifications tags shall be installed indicating the depth of bury of all hydrants. Additional tags shall be installed indicating the length of any extension installed.

2.20 BLOW-OFFS

- A. Blow-off hydrants shall be 2-inch post type with 2-1/2 inch hose nozzle having National Standard threads.
- B. Hydrant shall have 2-inch shut-off valve and integral drain.
- C. Hydrant shall have threaded inlet.
- D. Hydrant shall be furnished for 3'-6" bury, with cap chain, and shall be painted red.

- E. Blow-Off Hydrants shall be Mainguard Hydrant No. 77 by Eclipse-Kupferle Iron Foundry, or approved equal.

2.21 AIR RELIEF VALVES

- A. All water mains shall have 1"-2" single bodied air and or combination air and vacuum valves or 3"-10" dual bodied combination air and vacuum valve where indicated on the drawings. Valves shall have fiberglass reinforced nylon body or epoxy coated and lined cast iron bodies with stainless steel or non-metallic internal parts. Valve shall have rolling seal mechanism to allow full or partial opening and sealing of orifice or metal to metal stainless steel seating. The 1" – 2" valves float shall be made of foamed polypropylene and shall disrupt vortex and allow float to remain open until a 11 psi differential is achieved. Valves shall have a 250 psi working pressure. Valves shall be listed under NSF-61 and shall have ISO 9001 certificate. Valves shall be supplied with a male thread outlet or flanged outlet. All nipples and isolation valves for 1"-2" valves shall be brass or stainless steel. Ball style isolation valve shall be full port. Isolation valves for 3"-10" shall conform to Paragraph 2.12 – Gate Valves.
- B. Air release valves shall be A.R.I. Model D-040 for 1" and 2" or A.R.I. Model D-060-C HF NS for 3" – 10", or approved equal.

2.22 SERVICE SADDLES

- A. Service saddles for 1" and 2" NPT service taps shall be sized for use on C900 PVC. Service saddles shall be Romac 101NS.

2.23 TAPPING SLEEVES

- A. Tapping sleeves shall be designed for a minimum 200 psi working pressure and the material being tapped. All bolts and nuts shall be stainless steel.
 1. Tapping sleeves for 4-inch through 24-inch shall be stainless steel. Tapping sleeves shall have a MJ outlet. Tapping sleeves shall be Smith-Blair 663 or Ford FAST.
 2. Tapping sleeves for greater than 24-inches shall be Smith-Blair 622 with Flexi-Coat epoxy. Tapping sleeves shall have a MJ outlet.

2.24 SERVICE CONNECTION MATERIALS

- A. Materials and standards for larger meters (3-inch and greater) are not listed in the standard specifications. Larger meter installations require a site specific design. Please contact the City of Bryant Meter Department if you require a meter size 3-inch or greater.
- B. The minimum size of meters based upon demand (load) fixture units are as follows:

Demand (Load) Fixture Units	Demand (Load), gpm system with Flush Tanks	Demand (Load), gpm system with Flush Valves	Min Meter Size	Meter Series
1	0	0	5/8"	Mueller 400 Series ISS or Model MVR
2	1	0	5/8"	Mueller 400 Series ISS or Model MVR
3	3	0	5/8"	Mueller 400 Series ISS or Model MVR
4	4	0	5/8"	Mueller 400 Series ISS or Model MVR
5	6	0	5/8"	Mueller 400 Series ISS or Model MVR
10	8	27	3/4"	Mueller 400 Series ISS or Model MVR
20	14	35	3/4"	Mueller 400 Series ISS or Model MVR
30	20	41	1"	Mueller 400 Series ISS or Model MVR
40	25	47	1"	Mueller 400 Series ISS or Model MVR
50	29	52	1"	Mueller Model MVR
60	32	55	1-1/2"	Mueller Model MVR
70	35	59	1-1/2"	Mueller Model MVR
80	38	62	1-1/2"	Mueller Model MVR
90	41	65	1-1/2"	Mueller Model MVR
100	44	68	1-1/2"	Mueller Model MVR
140	53	78	1-1/2"	Mueller Model MVR
180	61	87	1-1/2"	Mueller Model MVR
200	65	92	1-1/2"	Mueller Model MVR
250	75	101	2"	Mueller Model MVR
300	85	110	2"	Mueller Model MVR
400	105	126	2"	Mueller Model MVR
500	125	142	2"	Mueller Model MVR

- C. Brass for meter materials shall be manufactured by Ford Meter Box Company, Inc. or Mueller Company. Equivalent cross referencing for corporation stops and meter setters shall be permitted as approved by the City of Bryant. Materials for standard meter sets 5/8", 1", 1-1/2", and 2" are as follows:

Single Meter Set

main diameter x 1" saddle	Romac 101NS
	A. Y. McDonald Hinged Saddle 3891
1" corporation	Ford FB1000-4-Q-NL
	Mueller B25008N
1" SDR 9 HDPE pipe w/ inserts	
5/8" x 3/4" x 12" meter yolk	Ford VB72-12W-44-43-SQ-NL
	Mueller 238B2567-R--93N
	A. Y. McDonald NL 726-207WX2D 33
1/2" x 16" SCH 40 PVC brace	
3/4" SDR 9 tail piece w/ insert, 4' long	
18" diameter x 24" deep SDR51 PVC meter box	DFW Plastics DFW1818TEX-1BA MINET BRY
18" solid black polymer meter lid	DFW Plastics, w/ Bryant logo

Double Meter Set

main diameter x 1" saddle	Romac 101NS
	A. Y. McDonald Hinged Saddle 3891
1" corporation stop	Ford FB1000-4-Q-NL
	Mueller B25008N
	A. Y. McDonald NL Plug Style 74701-22
1" SDR 9 HDPE pipe w/ inserts	
1" x 7.5" x 3/4" U branch	Ford U48-43-7.5-Q-NL
	Ford multipurpose end C31-23-NL (x2)
	Mueller H15363N (1" compression inlet)
	Mueller end connection H14222N (x2)
5/8" x 3/4" x 12" meter yolk	Ford VB72-12W-14-33-Q-NL
	Mueller 238B2567-RN
	A. Y. McDonald NL 726-207WX2D 33
1/2" x 16" SCH 40 PVC brace	
3/4" SDR 9 tail piece w/ insert, 4' long	
18" diameter x 24" deep SDR51 PVC meter box	
18" solid black polymer meter lid	DFW Plastics, w/ Bryant logo (DFW18AMR-1BA)

1 – inch Meter Set

main diameter x 1" saddle	Romac 101NS
	A. Y. McDonald Hinged Saddle 3891
1" corporation stop	Ford FB1000-4-Q-NL
	Mueller B25008N
1" SDR9 HDPE pipe w/ inserts	
1" x 12" meter yolk	Ford VB74-12W-44-44-Q-NL
	Mueller B24701RN
3/4" x 16" SCH40 PVC brace	
1" SDR 9 tail piece w/ insert, 4' long	
24" diameter x 24" deep SDR51 PVC meter box	
24" cast iron flat meter lid	East Jordan 111, w/ Bryant logo (35108004)

1-1/2 inch and 2 – inch Meter Set

main diameter x 2" saddle	Romac 101NS
	A. Y. McDonald Hinged Saddle 3891
2" brass close nipple	
2" ball valve	Ford B11-777-NL
	James Jones E1900
2" MIP x quick joint	Ford C84-77-Q-NL
	Mueller H15428N
2" SDR 9 HDPE pipe w/ inserts (x2)	
2" MIP x quick joint	Ford C84-77-Q-NL
	Mueller H15428N
2" meter setter	Ford VVB77-15HB-11-77-NL
	Mueller 605H1423--30N
	A. Y. McDonald NL 726-207WX2D 33
1" x 24" SCH40 PVC brace (x2)	
2" x 24" brass nipple tail piece	
36" diameter x 36" deep composite meter box w/ top ring	East Jordan 8428 Assembly (38003636A01)
28" outer cover, w/ lock	East Jordan 8428E, w/ Bryant lettering (00842845A01)
11" inner cover, w/o lock	East Jordan D Meter Cover (32193001)

2.25 TRACER WIRE

- A. Tracer wire shall be 12-gauge solid coated copper for underground burial.
- B. Jacket color shall be BLUE, and made of High Density Polyethylene (HDPE) or High Molecular Weight Polyethylene (HMWPE) designed for direct burial.
- C. Connectors shall be used for all splices or repairs. Connectors shall be moisture displacement style as manufactured by 3M DBR, or equal.
 - 1. A locate or conductivity test shall be performed prior to signing off on the project.
 - 2. Wire shall be new and shall have the size, grade of insulation, voltage, and manufacturer's name permanently marked on outer covering at regular intervals. Insulation shall be type THHN, THWN, or XHHW and rated 600 volt, 75 degrees C or higher for wet locations.
 - 3. Splice repair kits shall be 3M™ Model DBY-6 electrical/telephone direct bury splice kit or equal.
 - 4. Trace wire splice caps shall be Carsonite Model LCTSI508.
 - 5. Trace wire splice poles shall be Carsonite Model CTP307201.

2.26 MARKING TAPE

- A. Non-metallic water marking tape shall be warning tape as manufactured by Terra Tape "Extra Stretch", Rhino Marking and Protection Systems, Harris Industries, Inc., or approved equal.
- B. Tape shall have a minimum thickness of 4 mils and manufactured with heavy metal-free polyethylene tape that is impervious to all known alkalis, acids, chemical reagents, and solvents found in soil. The minimum overall width of the tape shall not be less than 3-inches. Standard rolls shall be 1000' length.
- C. The tape shall be color coded Safety Blue and imprinted with the following message: Caution – Buried Water Line Below

2.27 WATER LINE MARKERS

- A. Fiberglass post utility markers shall be fiberglass reinforced composite, 3.75 inches wide, and 72 inches long.
- B. Fiberglass post utility markers shall be blue in color.
- C. Fiberglass post utility markers shall have decals for visible identification of buried water line day or night.
- D. Signs shall be by Carsonite International, or equal.

PART 3 - EXECUTION

3.01 INSTALLATION

- A. Water Lines: Refer to Section 4100
- B. Water Service Lines: Refer to Section 4100

END OF SECTION 4000

SECTION 4100

INSTALLATION OF WATER PIPE, FITTINGS, AND MATERIALS

PART 1 – GENERAL

1.01 WORK INCLUDED

- A. Installation of water lines.
- B. Installation of water service lines.

1.02 RELATED WORK

- A. Section 2300 - Excavation, Backfilling, and Compacting.
- B. Section 4000 - Water Pipe, Fittings, and Materials.
- C. Section 3600 - Cast-In-Place Concrete.
- D. Section 5300 - Inspection and Testing of Water Lines and Service Lines.
- E. Section 6000 - Pavement Repair.
- F. Section 6100 - Lawn and Grass Restoration.

1.03 QUALITY ASSURANCE

- A. Inspect all pipelines per Section 5300 - Inspection and Testing of Water Lines and Service Lines.

1.04 SUBMITTALS

- A. Submit to the Engineer for approval all materials and procedures not described in these specifications.

1.05 PROTECTION

- A. In all cases, the Contractor is responsible for protecting public and private property and protecting any person or persons who might be injured as a result of the Contractors' Work.
- B. All utilities shown on the drawings may not represent the exact location; however, the Contractor is responsible for verifying these locations and contacting "Arkansas One Call System" before excavating.

PART 2 - PRODUCTS

2.01 BEDDING AND BACKFILL

- A. Refer to Section 2300 - Excavation, Backfilling, and Compacting.

2.02 PIPE, FITTINGS, AND MATERIALS

- A. Refer to Section 4000 – Water Pipe, Fittings, and Materials.

2.03 CONCRETE

- A. Refer to Section 3600 - Cast-In-Place Concrete.

PART 3 - EXECUTION

3.01 EXCAVATION - GENERAL

- A. Perform excavation and prepare bedding in accordance with Section 2300 - Excavation, Backfilling, and Compacting.
- B. Never lay pipe in a water-filled trench, or when trench conditions or weather are unsuitable for such Work.
- C. Divert surface water and de-water trenches during excavation.
- D. Excavate for bells so that the entire barrel of the pipe will be uniformly supported on the pipe bedding before placing pipe in the trench.

3.02 LAYOUT

- A. The Contractor shall install water lines, valves, fire hydrants, water meters, and other work as shown on the Drawings.

3.03 PIERS

- A. Install concrete piers as indicated on the plans per Section 3600 - Cast-In-Place Concrete.

3.04 COLD WEATHER INSTALLATION

- A. The City reserves the right to order pipe installation discontinued whenever, in its opinion, there is danger of the quality of work being impaired because of cold weather. The Contractor shall be responsible for heating the pipe and jointing material so as to prevent freezing of joints. Do not lay any pipe on frozen ground. **No flexible or semi-rigid pipe shall be laid when the air temperature is less than 32° F unless proper precautions per the manufacturer's recommendations are taken by the Contractor and the method is approved by the Engineer and City.**
- B. When pipes with rubber gaskets or resilient-type joints are to be laid in cold weather, sufficiently warm the gasket or joint material so as to facilitate making a proper joint.

3.05 PIPE INSTALLATION – PUSH-ON JOINTS

- A. Inspect each joint of pipe carefully internally and externally before it is placed in the trench. Plainly mark and separate from the remaining pipe any joint found to be cracked, warped, or otherwise damaged. Remove these damaged joints from the project site as soon as possible.
- B. Cut pipe in a neat and workmanlike manner without damage to pipe or pipe lining when trimming joint length. Cut ends shall be beveled according to the manufacturer's recommendation to prevent damage to the bell gasket.
- C. Use proper equipment for lowering sections of pipe into trenches. Lower pipe carefully into the trench so the spigot and bell will not become contaminated.
- D. Lay each pipe joint to line and grade as shown on the drawings. Keep a minimum of six inches between the pipe and the trench wall.

- E. Keep the pipe joints' interior clean from all dirt and other foreign matter as the Work progresses. Maintain the pipe's interior cleanliness until accepted or put in service.
- F. Close the open ends of the pipeline temporarily with an appropriate manufactured watertight plug at the end of each day's Work or when discontinuing pipe installation for an appreciable period.
- G. TRACER WIRE
 - 1. Tracer wire shall be installed on all buried PVC water lines and service lines.
 - 2. Tracer wire shall be installed 6-inches above the top of the pipe.
 - 3. Run wire continuous from valve box to valve box, meter box, or other access points. If no access point is available and a splice is required, provide a tracer wire splice pedestal consisting of a tracer wire splice pole and cap at nearest property line or at a location as approved by the Engineer.
 - 4. Pipe testing shall include trace wire. Contractor shall replace the trace wire along the pipe route for any areas in which the pipe cannot be located from the original trace wire installation.
 - 5. Wire breaks shall be repaired with repair kit at no additional expense to the Owner. Repair kits are to be used only to repair wire breaks that occur on tracer wire which has already been backfilled. The splice kit is used because there is not enough slack available in the tracer wire to splice the wire in a tracer wire splice pedestal. If the tracer wire is broke during installation, the Contractor should splice the wire in a tracer wire splice pedestal.
- H. MARKING TAPE
 - 1. Marking tape shall be installed on all buried water lines and service lines.
 - 2. Marking tape shall be installed 12-inches to 18-inches above the top of pipe.
- I. WATER LINE MARKERS
 - 1. Fiberglass post markers shall be installed every 1,000 feet (at nearest property line) and at highway crossings, creek crossings, railroad crossings, and changes in direction.

3.06 PIPE INSTALLATION – MECHANICAL JOINT CONNECTIONS

- A. The spigot end of the pipe, the bell of the connecting pipe, and the rubber gasket shall be thoroughly cleaned using soapy water and cloth, removing all foreign materials from the bells, especially the gasket seats as specified for push-on joints. Clean the gland in a similar manner. An approved pipe lubricant shall be applied to the spigot end of the pipe and the gasket.
- B. After the gland and gasket are placed on the spigot end of the pipe, a sufficient distance from the end to avoid fouling the bell, insert the spigot end in the fitting bell to the point of firm contact with the bell shoulder. Then advance the rubber gasket into the bell and seat in the gasket seat. **Hammering the gasket into the seat is not permitted.** Exercise care to center the spigot end within the bell. Bring the gland into contact with the gasket, enter all bolts, and make all nuts hand tight. Exercise continued care to keep the spigot centered in the bell.
- C. Make the joints tight by turning the nuts with a torque wrench: First partially tighten a nut, then partially tighten the nut 180 degrees away from it. Work around the pipe with uniformly applied tension until the required torque is applied to all nuts.

- D. The Contractor shall provide a torque wrench suitable for measuring tension on bolts for at least such a time as the workmen making the joints have gotten the "feel" of the required tension. At no time should handles longer than those supplied by the wrench manufacturer be permitted. The torque range shall be as follows:

<u>Diameter</u> <u>Inches</u>	<u>Range of Torque</u> <u>Foot Pounds</u>
5/8	45 – 60
3/4	75 – 90
1	85 – 100
1-1/4	105 – 120

- E. Proper actuation of the gripping wedges for restraining glands shall be ensured with torque limiting twist off nuts. Tightening sequence shall be as follows. First partially tighten a nut, then partially tighten the nut 180 degrees away from it. Work around the pipe with uniformly applied tension until the required torque is applied to all nuts. **Failure to follow proper tightening sequence will result in the disassembly of the joint, removal of the current restraining gland, and installation of a new restraining gland. Any damage to PVC pipe shall be removed as well.**
- F. All buried iron pipes, valves, and fittings shall be double poly wrapped.

3.07 SOLID SLEEVE INSTALLATION

- A. Solid sleeves shall be installed the same as mechanical joint connections for pipe installation.
- B. The maximum gap between the two pipes being connected by a solid sleeve shall be one-half (1/2) inch.

3.08 VALVE INSTALLATION

- A. Valves shall be jointed in accordance with the methods of jointing pipe as specified elsewhere herein. Valve stems shall be plumb and there shall not be any obstructions that will prohibit the installation of valve boxes directly over the stem. Mechanical joint retainer glands shall be installed on all valves with mechanical joint ends.
- B. All valves shall be firmly supported from below with compacted crushed stone up to and including 12-inch valves, or concrete for all valves 14-inches and greater.
- C. All valves shall be shall be poly wrapped.
- D. Valve boxes shall be installed over the operating nut of each valve and be of adequate length to reach the finished ground or paved surface. Valve boxes shall be installed with a HDPE Valve Box Alignment Device of the proper size and manufacture to fit the valve and the valve box. Boxes shall be firmly supported, plumb, and centered over the valve operating nut. No part of the box shall rest on the valve. The box cover shall be flush with the finished surface.
- E. Operating nut extensions shall be used when the top of the operating nut is greater than 4 feet from the top of finished surface. **The stem extension shall be of adequate length to reach from the valve operating nut to a point within 24-inches to 12-inches of the finished surface.**
- F. Tracer wire shall be brought up on the OUTSIDE of the valve box. A hole or notch shall be made through the valves box approximately 4-inches below the top. The tracer wire shall be pushed through the hole or notch. Approximately 12-inches of wire shall be coiled inside the valves box for traceability. The tracer wire shall not interfere with the insertion of the lid onto the valve box.

- G. All lids shall have a concrete pad with a minimum dimension of 18 inches square or round as appropriate. A concrete pad with a minimum dimension of 36 inches square or round as appropriate shall be installed for all valves 24-inches and larger.

3.09 FIRE HYDRANT INSTALLATION

- A. **Pipe used to install fire hydrants from the main line to the base of the fire hydrant shall be 6-inch ductile iron pipe. All pipe from the valve on the water main to the fire hydrant shall be fully restrained.**
- B. A separate maintenance valve, in addition to the valve anchored to the main, shall be installed on all fire hydrant leads exceeding 30 feet.
- C. Hydrants shall be thoroughly cleaned before setting, removing all dirt and foreign matter from the barrel and bottom section up to the main valve. The main valve shall be in the "closed" position and the waste outlet shall be free of any obstructions.
- D. **The Contractor shall take great care to protect the factory applied coating system.** Means and methods for the protection of the fire hydrant are the responsibility of the Contractor. At no time shall chains or other abrasive materials come into contact with the factory applied coating system.
- E. Minor touchup for "incidental" scratches is permitted using factory provided touchup kits.
- F. **When the factory applied coating system (from the bury line up), as identified by the City of Bryant, has damage other than "minor scratches," a new upper barrel section shall be ordered and delivered from the factory, inclusive of all internal working parts up to the operating stem breakaway. The upper barrel shall be replaced, and the damaged upper barrel returned to the factory at no cost to the City of Bryant.** This includes, but is not limited to, excessive scratches, appearance of rust, or other aesthetic flaws. Field repainting of new fire hydrant installations is not permitted.
- G. Hydrants shall be located a safe distance from driveways, roadways and narrow type sidewalks and in a manner to provide complete accessibility, and they shall stand plumb with nozzles at proper elevation. The hydrant's "bury line" shall be set at or no more than four (4) inches above the finished grade elevation; therefore the bottom of hydrant nozzles shall be 18 to 24 inches above the finished grade elevation.
- H. Installation of fire hydrant extensions shall be made in the presence of the Engineer or the Engineer's representative and shall be per the manufacturer's instructions. **The breakable flange and breakable stem coupling shall be removed and installed above ground level.**
- I. The Contractor shall, if necessary, rotate the hydrant barrel or nozzle section at the flanged joint to obtain the desired nozzle position as specified by the Engineer. The pumper nozzle shall be at a right angle to and face the street unless otherwise directed by the Engineer.
- J. The bowl or bottom of the hydrant shall be supported firmly on the bottom and shall be braced against unexcavated earth at the end of the trench with concrete reaction backing. Solid concrete blocks may be used to support the bottom of the hydrant. If considered necessary by the Engineer, the hydrant shall be tied to the branch pipe with suitable Series 300 stainless steel rods or clamps. These rods or clamps shall be furnished by the Contractor without additional compensation.
- K. A drainage bed shall be provided under and around the base of the hydrant of at least six (6) cubic feet in volume and extending at least six inches (6") above the drain outlet and shall consist of

ASTM #67 gravel. Under no circumstances shall the drain outlet on the hydrant or the drainage bed be connected to a sewer.

- L. Backfilling and tamping around hydrant barrels shall be continuous in operation.
- M. If a fire hydrant is not located inside a concrete paved area, then a 15.0" x 15.0" x 4.0" (deep) Class "B" concrete pad shall be poured just below the break-away joint of the fire hydrant barrel.
- N. Fire hydrants, immediately after installation, shall be covered and wrapped with a heavy cloth, water-resistant sack, or black polyethylene sheeting, well taped in place around the hydrant, to identify the hydrant as being "not in service".
- O. All fire hydrants installed within the City of Bryant water operational territory shall be painted with a base coat of Sherwin Williams (SW) Corothane I Mio-Aluminum B65S14.
- P. All fire hydrant nozzle caps and operating nuts shall be painted with paint according to Section 4000 – Water Pipe, Fittings, and Materials.
- Q. The City of Bryant shall provide the flow under fire conditions for each new fire hydrant installation based upon the current water modeling software or based upon a current fire hydrant fire flow test performed in the area.

3.10 METER SETTINGS

- A. Meter settings shall be installed where shown on the Drawings and/or as directed by the City. Installation shall be as per the Standard Details. Meter setters shall be installed in a horizontal and plumb position within the meter box and at a depth to provide the required space between the top of the meter and the bottom of the meter box lid.
- B. A drainage bed consisting of ASTM #67 stone shall be placed a minimum of 6-inches thick and 6-inches outside the edge of the bottom of the meter box. Non-woven filter fabric consisting of 8 oz/sy shall be placed on top of the drainage bed. The filter fabric shall extend 12-inch outside the edge of the bottom of the meter box. After the installation of the water service line, meter setter, meter box, and lid, the filter fabric shall be wrapped up the meter box and service line penetrations and taped securely to the meter box to provide a "dirt seal" before backfilling.
- C. Tracer wire shall be brought up on the INSIDE of the meter box with the water service line. Sufficient tracer wire shall be provide such that approximately 12-inches of wire will extend beyond the top of the box when pulled taunt. The tracer wire shall be loosely coiled and place inside the meter box. Do not wrap the tracer wire around the meter setter.
- D. The bottom of the meter setter connections shall be visible at the bottom of the meter box at the time of testing and of final inspection. Any dirt or debris in the bottom of the meter box shall be removed before the project is released for final payment and/or acceptance.
- E. The final grade at the meter box location shall be determined by the Engineer of Record and the meter box shall be placed at that grade. Final grade should take into account probable future installation of topsoil and/or sod. Any boxes falling in driveways or sidewalks shall be relocated at the expense of the developer or lot owner. No meters shall be set by the City until the meter box is adjusted to the proper grade.

3.11 BLOW-OFF INSTALLATION

- A. Blow-off hydrants shall be thoroughly cleaned before setting, removing all dirt and foreign matter from the barrel and bottom section up to the main valve. The main valve shall be in the "closed" position and the waste outlet shall be free of any obstructions.

- B. Blow-off hydrants shall be installed in such a manner to provide complete accessibility, and they shall stand plumb with nozzles at proper elevation. The discharge nozzle shall be a minimum of 24-inches above finished grade elevation.
- C. Hydrants shall be set plumb, resting on 15"x15"x4" concrete block, and backed with Class "B" concrete.
- D. The bowl or bottom of the blow-off hydrant shall be supported firmly on the bottom and shall be well braced against unexcavated earth on the backside of the blow-off hydrant. Solid concrete blocks, or other suitable material may be used to block the blow-off hydrant.
- E. A drainage bed shall be provided under and around the base of the blow-off hydrant of at least six (6) cubic feet in volume and extending at least six inches (6") above the drain outlet and shall consist of ASTM #67 gravel. Under no circumstances shall the drain outlet on the hydrant or the drainage bed be connected to a sewer.
- F. Backfilling and tamping around blow-off hydrant barrels shall be continuous in operation.
- G. Blow-off hydrants, immediately after installation, shall be covered and wrapped with a heavy cloth, water-resistant sack, or black polyethylene sheeting, well taped in place around the hydrant, to identify the hydrant as being "not in service".

3.12 TAPPING SADDLE INSTALLATION

- A. Tapping saddles shall be used for 1-inch and 2-inch service taps.
- B. The pipe shall be free of dirt and other debris before attaching tapping saddle. That part of the pipe barrel, other than concrete pipe, which will be in contact with the gasket of tapping saddles, shall be smooth. All rough areas on the pipe barrel shall be smoothed. The Contractor shall field verify all pipe and fitting dimensions. Tapping saddles shall be installed at least twenty-four (24) inches from bell joints, fittings, end of pipe joint, or another tap.
- C. Tapping saddles shall be bolted securely to the pipe. The face of the outlet shall be zero to ten (0-10) degrees from horizontal. The bolts for tapping saddles shall be alternately tightened "snug" and then alternately tightened to a torque as recommended by the manufacturer.
- D. The tapping valve shall be attached securely to the tapping saddle to provide a water tight seal. **Proper tools for installing brass hardware shall be used.**
- E. The pilot drill and shell cutter shall be in good condition. The pilot, shell cutter, and any other component of the tapping machine that will or may come into contact with the interior of the tap valve or potable water pipe, shall be thoroughly sterilized with straight bleach or super-chlorinated solution. The shell cutter shall be the size required to cut the full opening specified.
- F. **After the tap is complete and the tapping machine has been removed, the bolts for the tapping saddle must be re-torqued per the manufacturer's specifications to ensure a proper seal.**
- G. The tapping saddle shall be enclosed in polyethylene material in accordance with Paragraph 3.14 of these specifications.

3.13 TAPPING SLEEVE INSTALLATION

- A. The pipe shall be free of dirt and other debris before attaching tapping sleeve. That part of the pipe barrel that will be in contact with the gasket of tapping sleeve, shall be smooth. All rough

areas on the pipe barrel shall be smoothed. The Contractor shall field verify all pipe and fitting dimensions. Tapping sleeves shall be installed at least twenty-four (24) inches from bell joints, fittings, end of pipe joint, or another tap.

- B. Tapping sleeves shall be bolted securely to the pipe. The face of the outlet shall be plumb. Mechanical joint glands for tapping sleeves shall be installed in accordance with Paragraph 3.06 herein. The bolts for tapping sleeves shall be alternately tightened "snug" and then alternately tightened to a torque as recommended by the manufacturer.
- C. The tapping valve shall be bolted securely to the tapping sleeve. The tapping valve shall be adequately supported from beneath. The weight of the tapping valve shall not be supported by the tapping sleeve. A concrete "mud slab" at least six (6) inches thick shall be poured under the location of all tapping valves 14 inches and larger and the weight of the valve shall be supported by the mud slab. The tapping machine shall be bolted securely to the valve.
- D. After installation of the tapping sleeve and the tapping valve and before drilling through the pipe, the assembly shall be hydrostatically tested at the pressure specified in Section 5300, herein, by introducing water through the sleeve test tap.
- E. The pilot drill and shell cutter shall be in good condition. The pilot, shell cutter, and any other component of the tapping machine that will or may come into contact with the interior of the tap valve or potable water pipe, shall be thoroughly sterilized with straight bleach or super-chlorinated solution. The shell cutter shall be the size required to cut the full opening specified.
- F. Openings in the pipe barrel for tapping saddles installed on dry pipe shall be cut with a pilot drill and shell cutter. Torch cutting is not permitted.
- G. Tapping operations must not commence before inspection by the Engineer or his authorized representative. Tapping operations must not commence before the tapping assembly has passed a pressure test as detailed in Section 5300 herein.
- H. Only qualified operators shall operate the tapping machine. The "coupon" shall be withdrawn and be given to the Engineer for inspection. Care shall be exercised to avoid drilling or cutting the backside of the pipe by carefully assuring the engagement of the pilot drill and shell cutter shaft.
- I. **After the tap is complete and the tapping machine has been removed, the bolts for the tapping sleeve must be re-torqued per the manufacturer's specifications to ensure a proper seal.**
- J. All taps 14-inch and larger shall require the installation of a butterfly valve immediately after the tapping valve. The tapping valve shall be fully opened and abandoned in place.
- K. The tapping sleeve shall be enclosed in polyethylene material in accordance with Paragraph 3.14 of these specifications.
- L. Tapping sleeves shall be adequately thrust blocked with concrete.

3.14 INSTALLATION OF POLYETHYLENE PROTECTION MATERIAL

- A. Polyethylene material, either in tubing form or in the form of flat sheet or rolls, as specified herein, shall be placed around all buried mechanical joints of pipe and fittings, valves, fire hydrants, and all saddles, sleeves, and couplings, tapping saddles, and any other appurtenance with exposed bolts. Any and all iron or steel components installed below ground shall be wrapped with the polyethylene material.

- B. Ductile iron and steel pipe and appurtenances shall be completely encased in polyethylene tubing material. It is not the intent that the material form an enclosure that is absolutely air or water tight, but to prevent pipe to soil contact.
- C. Polyethylene tubing shall be applied to pipe by one of the following methods:
1. Method "A": Cut polyethylene tubes to a length approximately two feet (4') longer than the length of the pipe section. Slip the tubes around the pipe, centering it to provide a one foot (2') overlap on each adjacent pipe section, and bunching it accordion fashion lengthwise until it clears the pipe ends. Lower the pipe into the trench and make up the pipe joint with the preceding section of pipe. A shallow bell hole must be made at joints to facilitate installation of the polyethylene tube. After assembling the pipe joint, take bunched polyethylene from the preceding length of pipe, slip it over the end of the new length of pipe, and secure in place. Then slip the end of the polyethylene from the new pipe section of the end of the first wrap until it overlaps the joint at the end of the preceding length of pipe. Secure the overlap in place. Take up the slack width to make snug, but not tight, fit along the barrel of the pipe, securing the fold at quarter points with tape.
 2. Method "B": Cut polyethylene tubes to a length approximately one foot (1') shorter than the length of the pipe section. Slip the tubes around the pipe, centering it to provide six inches (6") of bare pipe at each end. Make polyethylene snug, but not tight; secure ends. Before making up a joint, slip two sections of six foot (6') length of polyethylene tube over the end of the preceding pipe section, bunching it accordion fashion lengthwise. After completing the joint, pull the two sections of six foot (6') length of polyethylene over the joint, overlapping the polyethylene previously installed on each adjacent section of pipe by at least two feet (2'); make snug and secure each end.
- D. Pipe-Shaped Appurtenances. Bends, reducers, offsets, and other pipe-shaped appurtenances shall be covered with double layers of polyethylene in the same manner as the pipe.
- E. Odd-Shaped Appurtenances. Valves, tees, crosses and other odd-shaped pieces which cannot practically be wrapped in a tube, shall be wrapped with two layers of flat sheets or split length of polyethylene tubes. The sheets shall be passed under the appurtenance and brought up around the body. Seams shall be made by bringing the edges together, folding over twice, and taping down. Slack width and overlaps at joints shall be handled as described in Paragraph 3.13.C.1 above. Tape polyethylene securely in place at valve stem and other penetrations.
- F. Openings in Tubing Material. Openings for branches, service taps, blow-offs, air valves, and similar appurtenances shall be made by making an "X" shaped cut in the polyethylene and temporarily folding the film back. After the appurtenance is installed, tape the slack securely to the appurtenance and repair the cut, as well as any other damaged areas in the polyethylene with tape.
- G. Junctions Between Wrapped and Unwrapped Pipe. Where polyethylene wrapped pipe joins a pipe that is not wrapped, extend the polyethylene tube to cover the unwrapped pipe a distance of at least two feet (2') and secure the end.
- H. The polyethylene material shall be secured around the pipe and appurtenances by at least three (3) circumferential wraps of tape (see Section 4000 for materials).
- I. All tongs, cables, or chains that are used for lifting pipe and appurtenances that have been encased in polyethylene material shall be adequately padded to prevent damage to the material.
- J. Repair any rips, punctures, or other damage to the polyethylene with tape or with a short length of polyethylene tube cut open, wrapped around the pipe and secured in place.

- K. Polyethylene material shall be stored on the job site in such a manner that it is not exposed to direct sunlight. Exposure during installation shall not exceed forty-eight (48) hours.
- L. Backfill material shall be the same as specified for pipe without polyethylene wrapping. Special care shall be taken to prevent damage to the polyethylene wrapping when placing backfill. Backfill material shall be free from cinders, refuse, boulders, rocks, stones, and/or other material that could damage polyethylene.

3.15 CONCRETE THRUST BLOCKS AND ANCHOR COLLARS

- A. Concrete thrust blocks and anchor collars shall be provided along the water line in accordance with the construction details, plan sheets, or as directed by the Engineer. The concrete mix (as defined in Section 3600 herein) shall be Class "B" for anchor collars and Class "A" for thrust blocks. All bends, tees, caps, plugs, and fire hydrants shall be thrust blocked unless specifically detailed in the construction drawings that no thrust blocking is required. Anchor collars shall be constructed on ductile iron pipe only; if the pipeline being restrained is primarily PVC or other non ductile iron pipe, at least one full joint of ductile iron pipe shall be inserted in the pipeline run to receive the concrete anchor collar.
- B. Concrete for thrust blocks and anchor collars shall be placed against undisturbed soil. The excavation shall be hand shaped and free of loose material. Forms shall be used to confine the concrete in areas other than that part that is in contact with undisturbed soil in the direction of the thrust.
- C. No concrete shall be placed around any part of a joint or placed so that it interferes with the removal of any joint accessories such as bolts, followers, threads, collars, couplings, etc. Fire hydrant drains shall not be restricted.
- D. The top of the concrete thrust block or anchor collar shall be struck off with a wood straight edge or float.
- E. Concrete shall not be placed when the temperature is below 40° F and dropping or below 35° F if the temperature is rising, unless approved by the Engineer.
- F. Admixtures are not to be used without the approval of the Engineer.
- G. All reinforcement shall be inspected by the Engineer prior to placement of concrete. All placement of concrete must be in the presence of the Engineer or his representative. The Contractor is cautioned that he may be required to remove, without compensation, any concrete placed in the absence of the Engineer or his representative.
- H. Backfill over concrete thrust blocks or anchor collars shall not be placed before the concrete has attained initial set.
- I. No thrust blocks shall be less than six inches (6") thick between the pipeline or appurtenances and undisturbed soil in the direction of thrust on pipes 12-inch diameter and smaller. On larger pipes, the thickness of thrust blocks shall be as directed by the Engineer. A thrust block with any component of its length to width to depth ratio exceeding two (2) shall be reinforced with steel reinforcement bars as directed by the Engineer. The Engineer will consider the size of the thrust block, the size of the water main, and the system pressure in the determination of the size and spacing of the steel reinforcement.
- J. The excavation shall be free of water before concrete is placed. Steel reinforcement shall be placed as specified on the drawings.

- K. The pipe or appurtenances to be in direct contact with concrete shall be cleaned before placing the concrete.
- L. The area of contact of the thrust blocks and anchor collars shall be sufficient to resist the thrust. This will vary depending on the safe bearing value of the soil. Suggested safe soil bearing values are as follows:

TYPE OF SOIL SUGGESTED SAFE BEARING VALUES (TONS \ SQ. FT.)	
Solid Rock	25.00
Hard Shale	6.00
Medium Shale	4.00
Soft Shale	2.00
Dry Clay or Gravel	4.00
Dry Sand or Loam	3.00
Wet Sand	2.00
Firm Clay	2.00
Soft Clay	1.50
Wet Clay	1.00

The above values are approximate, will vary considerably, and are intended to be used only as a guide. The Contractor is responsible for determining the soil bearing value or taking other action to assure that the bearing area is adequate to restrain the pipe or appurtenances.

- M. Where the soil is unstable or in the case of recent fill areas, the following procedures shall apply either singly or in a combination:
 1. Thrust blocks shall be of adequate size to restrain pipe or appurtenances by mass alone without depending on horizontal bearing of the soil.
 2. The excavation shall extend deep enough to contact firm soil and the thrust block concrete brought up to the pipe or appurtenances. The thrust block shall be constructed so that the block acts as a beam and will provide the restraint required. Such block shall be reinforced with steel reinforcing bars.
 3. Anchor blocks shall be constructed in a firm soil and tie rods extended to the pipe or appurtenances. Tie-rods shall be used only for temporary restraint. Concrete thrust blocks and/or anchor collars must be placed for permanent restraint.
- N. Thrust blocks for vertical bends shall be adequate to resist the thrust by mass alone when the thrust is upward.
- O. Thrust blocks and anchor collars shall be adequate to restrain the pipeline and appurtenances at design pressure equal to 150% of the static pressure at the lowest point with a minimum pressure of 200 psi. The following table lists the resultant thrust at certain fittings at a pressure of 100 psi. In order to determine the thrust at the test pressure, these values are to be multiplied by a factor equal to the design pressure divided by 100.

Thrust per 100 psi Pressure											
Thrust (tons)											
Fitting	6"	8"	12"	16"	18"	20"	24"	30"	36"	42"	48"
11 1/4	0.4	0.6	1.3	2.3	2.9	3.6	5.1	7.9	11.3	15.2	19.9
15	0.5	0.8	1.8	3.1	3.9	4.8	6.8	10.5	15.0	20.3	26.5
22 1/2	0.7	1.3	2.7	4.6	5.8	7.1	10.2	15.7	22.5	30.3	39.5
30	1.0	1.7	3.5	6.2	7.7	9.5	13.5	20.8	29.8	40.3	52.5

45	1.4	2.5	5.2	9.1	11.4	14.0	20.0	30.8	44.1	59.5	77.6
90	2.6	4.5	9.7	16.8	21.1	25.9	37.0	56.9	81.5	110.0	143.3
Plug/Tee/ Dead End	1.9	3.2	6.8	11.9	14.9	18.3	26.1	40.2	57.6	77.8	101.3

- P. Concrete thrust blocks and anchor collars on 12-inch and smaller pipelines shall have a minimum curing time of three days (72 hours) before any pressure is placed against the block or collar. Concrete thrust blocks and anchor collars on 14-inch and larger pipelines shall have a minimum curing time of seven days before any pressure is placed against the block or collar.
- Q. Concrete thrust blocks or anchor collars that fail to restrain the pipe or appurtenances shall be replaced by the Contractor at his expense.
- R. Reducers receiving an anchor collar shall be long bodied fittings.
- S. All water lines with dead ends shall be installed with an upstream valve, one full joint of ductile iron pipe with a MJ restraining gland, concrete anchor collar, a MJ cap with restraint, and a blow off assembly. The seat of the MJ restraining gland on the ductile iron pipe shall face the valve.
- T. Anchor collars subject to two-way thrust shall have two identical "A"/"B" reinforcement steel mats as shown in the Detailed Drawings. Anchor collars for 24" and smaller diameter pipe with two-way thrust shall have two (2) Mega-Lug retaining glands placed back-to-back, spaced just inside the two reinforcing steel mats. Anchor collars for 26" and larger diameter pipe shall have two weld-on thrust rings, spaced just inside the two reinforcing steel mats.

3.16 BACKFILLING AND INSPECTION

- A. Before backfilling, install concrete thrust blocks and anchor collars in accordance with the details at the location and interval and shown on the Drawings. Use concrete as specified in Section 3600-Cast-In-Place Concrete.
- B. After the pipeline is installed and visually inspected by the Engineer, backfill the trench per Section 2300-Excavation, Backfilling, and Compacting.
- C. Test the pipeline per Section 5300-Inspection and Testing of Water Lines and Service Lines.
- D. Repair all pavements per Section 6000-Pavement Repair.
- E. Repair all incidental damage to buildings, structures, utilities, pavements, landscaping, etc.
- F. Repair sodded and grass areas to original condition per Section 6100-Lawn and Grass Restoration.

3.17 WATER LINE INSTALLATION - AERIAL CROSSINGS

- A. Construct piers as shown on Drawings.
- B. Install encasement pipe on piers as shown on the Drawings.
- C. Insulate encasement as required by the City.

3.18 SEWER LINE CROSSINGS

- A. Sewer lines installed under a water line must have a clear distance between pipes of at least eighteen (18) inches.

- B. The sewer line shall be installed such that a joint of pipe is centered along the water line and the joints are as far as possible from the water line.
- C. If 18-inches of clearance cannot be provided or when the water main must pass under the sewer main, either the sanitary sewer main or the water main shall be encased in watertight steel encasement pipe a minimum of 10 feet either side of the line, centered over the point of crossing. The ends of the encasement pipe shall be sealed watertight. Refer to Section 3400 – Steel Encasement Pipe for end seals.

3.19 STORM SEWER CROSSINGS

- A. All water lines crossing under all concrete storm drains, or any storm drain 30-inch diameter and larger, or all storm drains with multiple pipe runs, shall be steel encased a minimum of 5 feet either side of the storm drain.

3.20 CUT AND CAP

- A. Water lines that are to be abandoned shall be cut and capped as shown on the detail drawings.
- B. Mechanical joint restraints and concrete shall be used to resist thrust loads.

3.21 ABANDON CORPORATION STOP

- A. All corporation stops used for testing and/or chlorination need to be properly abandoned by fully closing the corporation stop, removing all service line materials, installing a solid copper disk, and reinstalling the corporation nut resulting in a water tight seal in the event that the corporation valve fails.

END OF SECTION 4100

SECTION 4200

WATER LINE PRESSURE REDUCTION PROCEDURES

PART 1 - GENERAL

1.01 WORK INCLUDED

- A. This section covers the procedures associated with reducing water line pressure for construction.

1.02 PROCEDURES

- A. Water lines may need to have the pressure significantly reduced to facilitate construction in a project area, i.e tie-ins or cut and caps.
- B. Water pressure reductions shall be approved and coordinated with the City of Bryant Water & Sewer Department.
- C. The maximum amount of time that the line is permitted to be shut down shall be determined by the City of Bryant Water & Sewer Department.
- D. The Contractor shall have sufficient materials, labor, and necessary backup provisions in place prior to initiating water line pressure reduction to ensure that construction activities can be completed within the time determined by the City of Bryant Water & Sewer Department.
- E. A minimum of 72-hour notice shall be provided to each affected customer using the attached water pressure reduction notice.
- F. The Contractor shall distribute the notices and generate a list of each address that the notices are delivered to. The list shall be given to the City of Bryant Water & Sewer Department for their files.

1.02 CONSTRUCTION REQUIREMENTS

- A. The excavation in the project area shall be dewatered prior to pressure in the water main being reduced.
- B. All water pipe, fittings, and materials shall be disinfected per AWWA C651, latest revision.
- C. Immediately after construction is complete, the existing water lines shall be flushed thoroughly and background chlorine levels re-established.

END OF SECTION 4200

SECTION 5000
SEWER LINE CLEANING

PART 1 - GENERAL

1.01 WORK INCLUDED

- A. This Section covers the cleaning of sewer lines.

1.02 RELATED WORK

- A. Standard Detail Drawings
- B. Section 3100 – Installation of Sewer Pipe, Fittings, and Materials
- C. Section 3200 – Installation of Sewer Service Lines
- D. Section 3300 – Manholes
- E. Section 5100 – Sewer Line Television Inspection

1.03 SUBMITTALS

- A. The Contractor shall submit for approval manufacturer's brochures and specifications for his proposed cleaning equipment. The equipment and methods selected for cleaning shall be approved by the Engineer.

PART 2 - PRODUCTS

2.01 EQUIPMENT

- A. Equipment selected for cleaning shall be of a type generally recognized by the trade for the purpose being used and that has proved satisfactory. The equipment shall be capable of removing all roots, dirt, grease, rock and other deleterious material and obstructions from the sewer lines and manholes that would prevent efficient use of the inspection equipment.
 - 1. Hydraulic cleaning equipment shall be of a movable dam type and shall be constructed in such a way that a portion of the dam may be collapsed at any time during the cleaning operation to protect against flooding of the sewer. Sewer cleaning balls or other such equipment which cannot be collapsed instantly will not be considered acceptable cleaning equipment. The moveable dam shall be of the same diameter as the pipe being cleaned and shall provide a flexible scraper around the outer periphery to insure total removal of grease. If a line segment is found to be completely stopped up or plugged or heavily intruded with roots, then a mechanical root cutter shall be used.
 - 2. High velocity hydro-cleaning equipment shall be truck mounted for ease of operation. The equipment shall have minimum of 600 feet of 1 inch I.D. high pressure hose with a selection of two or more high velocity nozzles. The nozzles shall have a capacity of 60 GPM at a minimum working pressure of 1000 pounds per square inch (psi). The nozzles shall be capable of producing a scouring action from 15 degrees to 45 degrees in all size lines designated to be cleaned. Equipment shall also have a high velocity gun for washing and scouring manhole walls and floor. The equipment shall carry its own water tank capable of holding corrosive or caustic cleaning or sanitizing chemicals, auxiliary engines, pump and a hydraulically driven hose reel. All controls shall be located so that

equipment can be operated above ground with minimal interference to traffic and/or danger to the operator.

3. Mechanical cleaning equipment shall be used to remove heavy accumulations of silt, sludge, etc., and roots. Bucket machines shall be operated in pairs with each machine powered by an engine with a minimum of 16 horsepower (HP) to ensure sufficient pulling power. Machines shall be capable of operating at least two speeds to match job conditions. Sufficient accessories and tools shall be furnished to accomplish the required cleaning in a complete and efficient manner.
4. Power rodding machines shall be of a continuous rod type, capable of holding a minimum of 1000 feet of rod. The rod shall be specifically treated steel. The machine shall have a positive rod drive and produce a 2000 pound rod pull. To insure safe operation, the machine shall have a fully enclosed body and an automatic safety throw-out clutch.
5. Cleaning equipment shall be provided that includes an air conveying vacuum system to provide for the simultaneous removal of the debris flushed to the manhole.
6. A temporary debris catcher, as approved by the Engineer, shall be used in the downstream manhole. See Standard Detail Drawings.

2.02 PERSONNEL

- A. Contractor personnel shall be thoroughly familiar with all phases of sewer line cleaning to insure satisfactory end results without causing damage to the sewer lines or adjacent property.

PART 3 - EXECUTION

3.01 CLEANING EQUIPMENT

- A. Since the success of related work depends a great deal upon the cleanliness of the lines, the importance of the cleaning operation cannot be too strongly emphasized. The equipment selected for cleaning shall be capable of removing all dirt, grass, rocks and other deleterious materials from the sewer lines and manholes. Particular emphasis is placed on the removal of grease accumulations so that cracks and breaks can be observed during television inspection and so that joints can be isolated during testing and sealing operations.
- B. The Contractor shall make an inspection of the lines to be cleaned in order to determine the type of cleaning equipment that is required. It is anticipated that hydraulic cleaning will be adequate for most of the line segments.

3.02 CLEANING REQUIREMENTS

- A. Prior to inspection, the designated sewer lines, as shown on the project drawings, will be thoroughly cleaned as specified below:
 1. The sewer lines shall be cleaned by using standard mechanically powered or hydraulically propelled cleaning tools or combinations thereof, such as rodding machines, boring machines, hydraulic balls, cones, ferrets, or other similar devices.
 2. All roots, sludge, dirt, sand, rock, grease and other solid or semi-solid material resulting from the cleaning operations shall be removed at the downstream manhole without passing the material from section to section, which could cause stoppage of the lines or accumulation in the wet well and damage to pumping equipment. When cleaning equipment is used, a debris catch riser as shown in the standard details shall be used in

the downstream manhole so that both solids and water shall be trapped. All solids or semi-solids resulting from the cleaning operations shall be removed from the site and disposed of at no additional cost to the Owner. It the responsibility of the Contractor to secure a legal dump site for the disposal of this material.

3. Satisfactory precautions shall be taken to protect the sewer lines from damage that might be inflicted by the improper use of cleaning equipment. Whenever hydraulically propelled cleaning tools, which depend upon water pressure to provide their cleaning force or any tools which retard the flow of water in the sewer lines are used, precautions shall be taken to insure that the water pressure created does not cause any damage or flooding to public or private property being served by the manhole section involved. The flow of sewage present in the sewer lines shall be utilized to provide necessary fluid for hydraulic cleaning devices whenever possible. When additional quantities of water from fire hydrants are necessary to avoid delay in normal working procedures, the water shall be conserved and not used unnecessarily. No fire hydrant shall be obstructed or used when there is a fire in the area. Before using any water from the City water supply system, the Contractor shall obtain a hydrant meter from the Meter Department. The Contractor shall be responsible for the water meter and related charges for the set up, including the water usage bill. All expenses shall be considered incidental to cleaning.
4. **UNDER NO CIRCUMSTANCES SHALL SEWAGE OR SOLIDS REMOVED THEREFROM BE DUMPED ONTO STREETS OR INTO DITCHES, CATCH BASINS, STORM DRAINS OR SANITARY SEWER MANHOLES.**

END OF SECTION 5000

SECTION 5100**SEWER LINE TELEVISION INSPECTION****PART 1 – GENERAL****1.01 WORK INCLUDED**

- A. All new sewer lines constructed shall be inspected via internal television inspection.
- B. This section covers the television inspection of sewer lines.
 - 1. The inspection of each line shall be by a television (TV) camera especially designed to accurately show the condition of the lines from the interior and with the ability to pinpoint the locations of line faults and necessary repairs.
 - 2. A sewer line joint means the junction of two adjacent lengths of sewer pipe, and a fault is any crack too small to warrant pipe replacement. The term “manhole section” as used in these specifications shall mean the length of pipe connecting two manholes.

1.02 RELATED WORK

- A. Section 3100 – Installation of Sewer Pipe, Fittings, and Materials
- B. Section 3200 – Installation of Sewer Service Lines
- C. Section 5000 – Sewer Line Cleaning

1.03 SUBMITTALS

- A. The Contractor shall submit for approval manufacturer’s brochures and specifications for proposed TV equipment.

1.04 INSPECTION

- A. Immediately upon cleaning the sewer line in one location, it shall be televised to determine the condition of the line and location of existing service connections, etc.
- B. The sewer lines shall be visually inspected by TV camera. The section being inspected shall be suitably isolated from the remainder of the sewer line as necessary.
- C. The camera shall be moved through the line in either direction at a uniform slow rate not to exceed 60 feet per minute, by means of cable winches, or similar mechanisms. Under no circumstances shall the camera be tethered to a hydraulically propelled or high-velocity jet cleaning device while the cleaning device is on.
- D. The camera shall stop at each service connection and provide a view up the service line.
- E. Telephone, or similar suitable means of communications, shall be set up between the two winches, the pumping unit and the monitor control.
- F. Under certain conditions, it may be impossible for inspection equipment to pass through a manhole section due to damaged pipe or other obstructions not correctable by internal methods. In such cases, the Engineer will be notified.

- G. TV inspection will be done one manhole section at a time and the flow in the section being inspected will be suitably controlled. Sewer flow will not exceed those shown below as measured in the manhole:
- | | |
|----------------|----------|
| 6" - 10" Pipe | 1 inch |
| 12" - 14" Pipe | 2 inches |
| 14" - 24" Pipe | 3 inches |
| Over 24" Pipe | 4 inches |
- H. The Contractor will make all provisions for pumping or bypassing the flow around the manhole section and the cost shall be incidental to TV inspection. Contractor shall not be allowed to float the camera unless permitted by the City.
- I. It is possible that some sections of the sewer line cannot be televised; therefore, house or building connection lines will have to be located on the ground by the Contractor. All cost for locating these service lines shall be included in the cost bid for house or building service line reconnection.

PART 2 - PRODUCTS

2.01 TELEVISION INSPECTION EQUIPMENT

- A. The television camera and monitoring equipment shall be specifically designed and constructed to perform the work as specified. The camera shall be operative in conditions of 100% humidity and/or under water. The camera shall be small enough to pass through a 6 inch diameter sewer and shall be waterproof with a self contained lighting system capable of producing enough light to produce clear, bright, sharp pictures on the monitor. The lighting and camera quality shall be suitable to allow a clear, in focus picture of a minimum of 6 linear feet of the entire inside periphery of the sewer pipe. Picture quality and definition shall be to the satisfaction of Engineer; otherwise, the equipment shall be removed from the line without pay.
- B. The monitor shall be located within a temperature controlled television unit that will accommodate three people to watch the sewer line inspection. The monitor will have a 12-inch minimum viewing screen. The Engineer will have access to view the television monitor at all times.

PART 3 - EXECUTION

3.01 TELEVISION INSPECTION BY THE CONTRACTOR

- A. The Contractor shall furnish video media of the lines televised to the Engineer for review and comments, which may require up to thirty (30) calendar days from the date submittal to the City. The video media shall be DVD format. Video shall play in a standard DVD player without the need of viewing software. Each video media shall be permanently labeled with the following information furnished:
1. Project Job Number
 2. Manhole to Manhole Designation
 3. Name of Contractor
 4. Date Televised
- B. The following information shall be recorded and visible onscreen for 10 seconds immediately before the start of televising each line segment:

1. Project Job Number
 2. Manhole to Manhole Designation (Number, Pipe Material, Size of Line, and Direction of Televising)
 3. Name of Contractor
 4. Date Televised
 5. Street and or Easement Location
 6. Drawing Sheet Number
- C. A continuous uninterrupted recording of distance from the insertion manhole shall be visible at the lower left corner of the screen at all times during inspection.
- D. The following information shall be provided in hard copy to accompany each tape:
1. Project Job Number
 2. Name of Contractor
 3. Date Televised
 4. Street or Other Location
 5. Upstream Manhole Designation
 6. Downstream Manhole Designation
 7. Pipe Material
 8. Pipe Diameter
 9. Direction of Televising (Downstream or Upstream)
 10. Continuous Time Log Designating Start and Finish of Each Line Segment Televised. Time shall begin at 0hr 0min 0sec at the beginning of each tape.
 11. Location of Service Connections
- E. Media will become the property of the City. If the video is of such poor quality that the Engineer is unable to evaluate the condition of the sewer line or to locate service connections, the Contractor will be required to retelevising and provide a good video of the line at no additional cost to the City.

END OF SECTION 5100

SECTION 5200
INSPECTION AND TESTING OF
SEWER LINES, MANHOLES, AND SERVICE LINES

PART 1 - GENERAL

1.01 WORK INCLUDED

- A. This section covers the inspection and testing of sewer lines, manholes, and service lines. Holiday testing shall be required on all epoxy line manholes and sewer wet wells. Testing is required before final acceptance of sewer lines and service lines by the City.

1.02 RELATED WORK

- A. Section 3000 – Sewer Pipe, Fittings, and Materials
B. Section 3100 – Installation of Sewer Pipe, Fittings, and Materials
C. Section 3200 – Installation of Sewer Service Lines
D. Section 3300 – Manholes
E. Section 5100 – Sewer Line Television Inspection

1.03 SCOPE OF WORK

- A. All pipelines shall be inspected and tested before final acceptance. The methods to be used are as follows:
1. New Gravity Sewer Lines
 - a. Visual inspection during installation and before backfill
 - b. Low pressure air test.
 - c. Television inspection.
 - d. Mandrel test (Flexible pipes only)
 - e. Final Visual Inspection
 2. Manholes
 - a. Visual inspection during installation and before backfill.
 - b. Vacuum testing.
 - c. Final visual inspection.
 - d. Holiday test (epoxy coatings).
 3. Replacement Sewer Lines and Point Repairs

- a. Visual inspection during installation and before backfill.
 - b. Low pressure air test/exfiltration, infiltration.
 - c. Television inspection.
 - d. Mandrel test.
 - e. Final visual inspection.
4. Force Mains
- a. Visual inspection during installation and before backfill.
 - b. Hydrostatic pressure test.
 - c. Tracer wire continuity test.
5. Service Lines
- a. Visual inspection during installation and before backfill.
 - b. Low pressure air test.
 - c. Exfiltration test.

1.04 DELIVERABLES

- A. **The Engineer shall provide a complete and comprehensive testing report summary complete with all inspection and testing dates and results.**

PART 2 - PRODUCTS

- A. Not Used.

PART 3 - EXECUTION

3.01 VISUAL INSPECTION DURING INSTALLATION AND BEFORE BACKFILL

- A. The Engineer shall be responsible for inspecting sewer lines, manholes, and service lines during all phases of construction. The Engineer shall provide full time inspection services. All work not conforming to these specifications that is discovered during this inspection phase will be corrected by the Contractor.

3.02 PRESSURE TEST FOR GRAVITY SEWER PIPELINES

- A. The Contractor will perform pressure tests on all gravity sewer lines.
- B. Lines will not be accepted until they pass all required tests.
- C. Perform the tests in the presence of the City representative. Provide at least 48 hours notice before beginning testing.

- D. The primary test method is the Low Pressure Air Loss test.

3.03 LOW PRESSURE AIR LOSS PROCEDURE FOR GRAVITY SEWER PIPELINES

- A. Plug all pipe outlets with suitable test plugs. Brace each plug securely.
- B. Pipe air supply to pipeline to be tested so that air supply may be shut off, pressure observed, and air pressure released from the pipe without entering the manhole. Install a valved branch in the supply line past the shut-off valve terminating in a 1/4" female pipe thread for installation of the test gauge.
- C. Add air slowly to portion of pipe under test until test gauge reads at least 4 psig, but less than 5 psig.
- D. Shut air supply valve and allow at least two minutes for internal pressure to stabilize.
- E. The pressure shall then be decreased to 3.5 psig.
- F. Upon reaching 3.5 psig, the time in minutes.seconds for the pressure to fall 1 psig so that pressure at the end of time of the test is at least 2.5 psig shall be observed.
- G. Compare observed time with minimum allowable times in the following chart for pass/fail determination.

TEST CHART FOR AIR TESTING SEWERS												
Leakage Testing of Sewers by Low Pressure Air Loss (Time Pressure Drop Method) (Min.Sec)												
Pipe Diameter In.	Minimum Time, Min : s	Length for Minimum Time, ft.	Time for Longer Length, s	Specification Time for Length (L) Shown, min:s								
				100ft	150ft	200ft	250ft	300ft	350ft	400ft	450ft	
4	1:53	597	0.190 L	1:53	1:53	1:53	1:53	1:53	1:53	1:53	1:53	1:53
6	2:50	398	0.427 L	2:50	2:50	2:50	2:50	2:50	2:50	2:50	2:51	3.12
8	3:47	298	0.760 L	3:47	3:47	3:47	3:47	3:47	3:48	4:26	5.04	5.42
10	4:43	239	1.187 L	4:43	4:43	4:43	4:57	5:56	6:55	7.54	8.54	
12	5:40	199	1.709 L	5:40	5:40	5:42	7:08	8:33	9:58	11.24	12.50	
15	7:05	159	2.671 L	7:05	7:05	8:54	11:08	13:21	15:35	17.48	20.02	
18	8:30	133	3.846 L	8:30	9:37	12:49	16:01	19:14	22:26	25.38	28.51	
21	9:55	114	5.235 L	9:55	13:05	17:27	21:49	28:11	30:32	34.54	39.16	
24	11:20	99	6.837 L	11:24	17:57	22:48	28:30	34:11	39:53	45.35	51.17	
27	12:45	88	8.653 L	14:25	21:38	28:51	36:04	43:18	50:30	57.42	64.54	
30	14:10	80	10.683 L	17:48	26:43	35:37	44:31	53:25	62:19	71.13	80.07	
33	15:35	72	12.926 L	21:33	32:19	43:56	53:52	64:38	75:24	86.10	96.57	
36	17:00	66	15.384 L	25:39	38:28	51:17	64:06	76:55	89:44	102.34	115.23	

- H. Where groundwater level is above the crown of the pipe being tested, increase test pressure at the rate of 1 psi for every 2.5 feet of water above the crown.
- I. Air Testing Safety Requirements:
 - 1. Securely brace plugs used to close the sewer pipe for the air test; this is to prevent the unintentional release of a plug which can become a high velocity projectile. For example: four pounds (gauge) air pressure develops a force against the plug in a 12" diameter pipe

of approximately 450 pounds; this force can propel a 12-inch plug weighing 10 pounds to supersonic speeds.

2. Locate gauges, air piping manifolds, and valves at the top of the ground. Entry by anyone into a manhole where a plugged pipe is under pressure is strictly prohibited.

3.04 HOLIDAY TESTING FOR EPOXY LININGS

- A. High voltage holiday detection for coating systems installed in corrosive environments, when it can be safely and effectively employed, shall be performed to ensure monolithic protection of the substrate. After the coating product(s) have cured in accordance with manufacturer recommendations, all surfaces shall be inspected for holidays in accordance with NACE RPO 188-99, Discontinuity (Holiday) Testing of New Protective Coatings on Conductive Substrates. All detected holidays shall be marked and repaired according to the coating product(s) manufacturer's recommendations.
- B. Test voltage shall be a minimum of 100 volts per mil of coating system thickness.
- C. Detection of a known or induced holiday in the coating product shall be confirmed to ensure proper operation of the test unit.
- D. All areas repaired shall be retested following cure of the repair material(s).
- E. In instances where high voltage holiday detection is not feasible a close visual inspection shall be conducted and all possible holidays shall be marked and repaired as described above.
- F. Documentation of areas tested, equipment employed, results, and repairs made shall be submitted to the City/Engineer by Contractor.

3.05 TELEVISION INSPECTION

- A. The Contractor shall televise all newly installed sewer mains as follows:
 1. Television inspection shall be performed no less than 30-days after the pipe has been backfilled. Inspection shall be performed after mandrel testing, if applicable.
 2. The Contractor shall clean all lines thoroughly prior to the start of televising.
 3. Prior to performing the video test, a 5 gallons of clean water per 100 feet of sewer line shall be poured down the sewer main in order to highlight low spots.
 4. The Contractor shall televise each segment of pipe.
 5. The Contractor shall review the video for possible defects in material or workmanship.
 6. The Contractor shall correct any defects discovered during the television inspection at the Contractor's expense.
 7. The Contractor shall deliver to the Engineer final video and logs after all defects have been repaired.

3.06 MANDREL TEST

- A. Mandrel testing shall be performed no less than 30-days after the pipe has been backfilled.

- B. The maximum allowable pipe deflection is five (5) percent of the inside pipe diameter.
- C. Any sewer pipe which fails the mandrel test prior to final acceptance will not be accepted by the City until the defects are corrected.
- D. All mandrel tests shall be performed by the Contractor while observed by City personnel.

3.07 SUPPLEMENTAL MANDREL TESTING

- A. The City may at any time after final acceptance perform supplemental mandrel testing on pipelines constructed of flexible pipe material. These supplemental tests will be performed as detailed above with a maximum allowable long term deflection of five percent (5%).
- B. Any sewer pipe which fails the mandrel test prior to expiration of the maintenance bond will be corrected by the Contractor at the Contractor's expense. If the Contractor fails to correct these defects after a reasonable time, the City will correct the defects and file a claim with the bonding company.

3.08 FINAL VISUAL INSPECTION

- A. Upon completion of the above tests the Engineer will perform a final visual inspection of sewer lines and manholes.
- B. A punch list of defects (including obvious running leaks) will be prepared and sent to the Contractor for correction at the Contractors' expense.

3.09 INSPECTION FOR SERVICE LINES

- A. All building sewer installations shall be inspected and approved by an authorized City inspector.
- B. Backfill may only be placed on the completed portions of a building sewer following inspection. No approval certificate shall be issued until all portions of a building sewer from the main connection to the building foundation have been inspected and approved by an authorized inspector. At the time of inspection, the pipe should be in place in the trench and "safed-up", but the top half of the pipe barrel exposed. No approval will be given for building sewers all or a portion of which are covered at the time of inspection.
- C. All building sewers are subject to testing to insure water tightness. All tests must be performed in the presence of the Engineer. Tests may be either by:
 1. Water Loss Test Procedure; or,
 2. Low Pressure Air Loss Procedure.
- D. If, in the opinion of the Engineer, the line in question is properly installed and free from open joints and breaks, building sewers constructed entirely of cast iron soil pipe may be connected to the city sewer without testing.
- E. Low Pressure Air Loss Procedure
 1. Plug securely both ends of the line to be tested.
 2. Charge the line with air to a pressure of 4.5 psig.
 3. Allow at least five minutes for the temperature in the pipe to stabilize.

4. Measure the time required for a one (1.0) psi drop in pressure.
5. The minimum time for a one psi loss is $28.5 \times d$ seconds where d = the nominal diameter in inches of the pipe being tested.

3.10 PRESSURE TEST FOR FORCE MAINS

- A. Perform hydrostatic leakage tests for force mains the same as water pipe, see Section 5300, by filling the force main with water and increasing the pressure to a testing pressure of 150% of the working pressure with a minimum of 100 psi and a maximum pressure of 250 psi.
- B. The duration of the leakage test shall be two hours.
- C. The maximum allowable leakage rate shall be 1 gallon per foot diameter of pipe per 1000 feet of force main for the duration of the 2 hour test.
- D. The force main will not be accepted until the actual leakage is equal to or less than the allowable. In addition, all obvious leaks shall be repaired.

3.11 MANHOLE TESTING

- A. The Contractor shall vacuum test all new manholes constructed.
- B. Precast manholes shall be vacuum tested prior to backfill.
- C. The Contractor shall vacuum test all manholes that have been sealed (waterproofed).
- D. The Contractor shall vacuum test all manholes that have been epoxy lined.
- E. Manholes shall be tested in accordance with ASTM C 1244, latest edition. Vacuum test shall not be performed earlier than 7 days after construction for cast in place manholes. The Contractor shall provide all testing equipment, pump, hosing, seal, and other incidentals. Vacuum test head shall be positioned at the top of the casting (the surface on which the manhole cover rests, to include grade rings) in accordance with the equipment manufacturer's instructions. A vacuum of 10-inches of mercury shall be drawn and the vacuum pump isolated by the shut-off valve on the test head connection. When valve is closed, time measurement shall commence, and the time required for vacuum drop to 9-inches of mercury shall be observed and recorded. Manholes shall pass if the time for the vacuum reading to drop from 10-inches of mercury to 9-inches of mercury meets or exceeds the time values in seconds in the following table.

Depth (feet)	Diameter (inches)								
	30	33	36	42	48	54	60	66	72
<10	11	12	14	17	20	23	23	29	33
10	14	15	18	21	25	29	33	36	41
12	17	18	21	25	30	35	39	43	49
14	20	21	25	30	35	41	46	51	57
16	22	24	29	34	40	46	57	58	67
18	25	27	32	38	45	52	59	65	73
20	28	30	35	42	50	53	65	72	81
22	31	33	39	46	55	64	72	79	89
24	33	36	42	51	59	70	78	87	97
26	36	39	46	55	64	75	85	94	105

28	39	42	49	59	69	81	91	101	113
30	42	45	53	63	74	87	98	108	121

- F. Manholes showing greater than the allowable leakage shall be repaired and re-tested until a satisfactory leakage result is obtained.

3.12 TRACER WIRE CONTINUITY TESTING

- A. Contractor shall perform a continuity test on all tracer wire in the presence of the Engineer or the Engineers’ representative. If the tracer wire is found to be not continuous during testing, Contractor shall repair or replace the failed segment of wire at their own expense.
- B. A final continuity test shall be performed by a Water and Sewer Department representative before the project will be accepted by the City. If the tracer wire is found to be not continuous during testing, Contractor shall repair or replace the failed segment of wire at his own expense.

END OF SECTION 5200

SECTION 5300**INSPECTION AND TESTING OF
WATER LINES AND SERVICE LINES****PART 1 - GENERAL****1.01 WORK INCLUDED**

- A. This section covers the inspection and testing of water lines and services lines. Testing is required before final acceptance of water lines and service lines by the City.

1.02 RELATED WORK

- A. Section 4000 – Water Pipe, Fittings, and Materials
- B. Section 4100 – Installation of Water Pipe, Fittings, and Materials

1.03 SCOPE OF WORK

- A. All pipelines shall be inspected and tested before final acceptance. The methods to be used are as follows:
 - 1. New Water Pipelines
 - a. Visual inspection during installation and before backfill. b Hydrostatic pressure test.
 - c. Disinfection.
 - d. Bacteriological sampling.
 - e. Final Visual Inspection.
 - f. Tracer wire continuity test.
 - 2. Water Meter Setters
 - a. Visual inspection during installation and before backfill.
 - b. Final Visual Inspection.
 - 3. Service Lines
 - a. Visual inspection during installation and before backfill. b Hydrostatic pressure test.
 - c. Final Visual Inspection
 - d. Tracer wire continuity test.

1.04 DELIVERABLES

- A. The Engineer shall provide a complete and comprehensive testing report summary complete with all inspection and testing dates and results.

PART 2 - PRODUCTS

- A. Not Used.

PART 3 - EXECUTION

3.01 VISUAL INSPECTION DURING INSTALLATION AND BEFORE BACKFILL

- A. The Engineer shall be responsible for inspecting water lines, water meter setters, and service lines during all phases of construction. The Engineer shall provide full time inspection services. All work not conforming to these specifications that is discovered during this inspection phase will be corrected by the Contractor.

3.02 PRESSURE TEST FOR TAPPING SLEEVES

- A. The contractor shall provide all pumps or other equipment necessary to test the tapping sleeve before making a tap. The duration of the hydrostatic leakage test on tapping sleeves shall be thirty (30) minutes at 225 psi with zero leakage.

3.03 PRESSURE TEST FOR WATER PIPELINES AND SERVICE LINES

- A. After completion of construction of all water lines or sections thereof, the Contractor shall flush, test and disinfect the new water lines and in accordance with the Engineer of Record's plan as described below.

- B. Flushing

1. All water for flushing, testing and disinfecting water lines shall be supplied and paid for by the Contractor. Water meters shall be obtained from the City of Bryant Meter Division. Water used for high rate flushing shall not be metered through a contractor issued water meter. Actual water flow rates used during flushing operations shall be determined by the City of Bryant by using either pitot style gauges or high rate water meters. Volume shall be determined by multiplying the measured flow rate times the duration of flushing in minutes. Water used for flushing shall be billed to the contractor at the current wholesale water rate plus applicable taxes.
2. The work shall be coordinated to ensure that it will not be carried on during periods of high water usage. Water valves or other appurtenances on the existing water system, new tapping valves, or valves or appurtenances that have been accepted by the City, shall only be operated by, or under the direct supervision of, the City of Bryant Water & Sewer Maintenance Division.
3. The Contractor shall fill and flush the newly constructed lines and visually check all combination air release and vacuum valves, blow-off valve assemblies, line valves, fire hydrants, and meter setters to assure proper operation.
4. The Engineer of Record shall develop a flushing plan to ensure that all lines are properly flushed. The plan should specify the sequence in which valves and hydrants are to be opened and the duration thereof, ensuring complete flushing and protecting the City's water system from construction contaminated water. The volume to be flushed shall be no less than three (3) but no more than five (5) times the volume of the main to be flushed, and shall be metered by the City. The flow shall be such that a flushing velocity of not less than 2.5 feet per second and preferably 3.5 feet per second or greater is attained.

C. Hydrostatic Testing

1. All pipe shall be tested as set out in AWWA C600, latest revision. Tests will be conducted only after the line is completed, including all taps and meter settings as required and the backfill completed. These tests shall be performed by the Contractor in the presence of the City Inspectors and the Engineer of Record. The Contractor shall furnish all necessary pressure gauges, meters, and pumps and make all taps and connections.
2. Each valved section of pipe shall be slowly filled with water and the specified test pressure shall be applied by means of a pump connected to the pipe in a manner satisfactory to the Engineer. Before applying the test pressure, all air shall be expelled from the pipe by permanent taps or corporation cocks where necessary.
3. Test pressure shall be either 150 percent of the static pressure at the lowest points or 200 psi, whichever is greater, not to exceed 250 psi at the lowest point. The contractor shall provide all pumps or other equipment necessary to maintain the test pressure within +/-5 psi at the test point for a period of two (2) hours. All interior valves including guardian valves on fire hydrants and other appurtenances shall be open during all tests.
4. The test pressure shall not vary by more than ± five (5) psi for the duration of the test. During the duration of the two hour test, if the test pressure drops more than 5.0 psi from the start pressure, the test shall be terminated and considered failure due to assumed leaks in the tested pipe section. If the pressure rises beyond the allowed 5 psi variance, the test shall be terminated and remaining air shall be purged from the pipeline.

D. Leakage

1. The leakage test shall be conducted concurrently with the pressure test. Leakage shall be defined as the quantity of water that must be supplied into the newly laid pipe, or any valved section thereof, to maintain pressure within 5 psi of the above specified test pressure after the air in the pipeline has been expelled and the pipe has been filled with water.
2. **The maximum allowable leakage rate shall be 1 gallon per foot diameter of pipe per 1000 feet of water line for the duration of the 2 hour test.**

D (inches)	6	8	10	12	14	16	18	20	24	36	42
Allowable	0.50	0.67	0.83	1.00	1.17	1.33	1.50	1.67	2.00	3.00	3.50

3. Upon completion of a two hour test where the test pressure did not vary by more than ± five (5) psi, the CONTRACTOR shall determine the leakage amount by measuring the amount of “make-up” water necessary to restore the original starting pressure.
4. Should any test of pipe laid disclose leakage greater than that specified, the leak(s) shall be located and repaired and the line shall be re-tested at the Contractor’s expense. All visible leaks shall be repaired regardless of the amount of leakage. It may be necessary to utilize leak detection equipment to locate not visible leaks at the Contractor’s expense.

3.04 DISINFECTION

- A. After successful pressure testing, the line(s) shall be flushed at a velocity equal to or greater than 2.5 feet per second. The line shall then be disinfected in accordance with AWWA C651, latest revision, for Disinfecting Water Mains, continuous feed method, except that the placing of hypochlorite granules into the main during construction will not be permitted.

- B. The Contractor shall provide a test/chlorine tap no greater than 10' downstream from the beginning of the new water line. All excavation, installation, use of and proper abandonment of the test tap is the responsibility of the Contractor.
- C. The final concentration of chlorine inside the main shall be 25 parts per million (ppm) at all locations and shall be maintained for a minimum of 24 hours. The chlorine residual at the end of the 24 hour period shall not be less than 10 ppm. The contractor shall supply all test kits necessary to verify chlorine concentrations.
- D. The contractor shall operate all valves and hydrants in the treated section of water line during the initial 24 hours to ensure disinfection of the appurtenances.
- E. The contractor shall take great care when flushing the line to assure proper drainage is available to prevent harm at any adjacent downstream location.
- F. Disposal of the disinfecting water shall be in a manner that will protect the public and the receiving waters from harmful concentrations of chlorine. Dechlorination of the disinfecting water shall be in accordance with AWWA C655, Field Dechlorination, latest edition. A dechlorination plan shall be prepared by the Engineer of Record.
- G. After disinfection is complete, the Contractor shall then flush the disinfecting solution from the lines to a point that the chlorine concentration is back down to the same level as the treated water from the distribution system. The treated water lines will then be tested before being placed into service.

3.05 BACTERIOLOGICAL SAMPLES

- A. Bacteriological samples shall be taken by City personnel only. Samples shall be taken on two consecutive days and shall be taken only on Monday, Tuesday, Wednesday, or Thursday. Before a line is placed in service, two consecutive series of samples which are not collected on the same day and are taken no more than 4 days apart must show that the water is bacteriologically safe for drinking purposes.

3.06 FINAL VISUAL INSPECTION

- A. Upon completion of the above tests the Engineer will perform a final visual inspection of water pipelines and meters.
- B. A punch list of defects (including obvious running leaks) will be prepared and sent to the Contractor for correction at the Contractors' expense.

3.07 TRACER WIRE CONTINUITY TESTING

- A. Contractor shall perform a continuity test on all tracer wire in the presence of the Engineer or the Engineers' representative. If the tracer wire is found to be not continuous during testing, Contractor shall repair or replace the failed segment of wire at their own expense.
- B. A final continuity test shall be performed by a Water and Sewer Department representative before the project will be accepted by the City. If the tracer wire is found to be not continuous during testing, Contractor shall repair or replace the failed segment of wire at his own expense.

END OF SECTION 5300

SECTION 6000**ASPHALT PAVEMENT REPAIR****PART 1 - GENERAL****1.01 WORK INCLUDED**

- A. This section covers the materials and procedures used in the repair of asphalt roads, streets, or other public rights-of-way where a water lines, sewer line, or structure is constructed.

1.02 RELATED WORK

- A. Section 2300 - Excavation, Backfilling and Compacting.

1.03 REGULATIONS AND STANDARDS

- A. All permanent repairs of streets, roads, sidewalks, other public rights-of-way, private drives, private parking lots, etc. shall comply with the requirements shown on the Standard Detail Drawings and Tables. The Contractor is responsible for following the requirements of all local Ordinances, Regulations, or Codes governing the repairs to roads, streets, or other public rights of way. In particular:
 1. Repair of State Highways: per requirements of the Arkansas State Highway Commission.
 2. Repair of county roads: per requirements of the County Roads Department.
 3. Repair of City of Bryant streets, sidewalks, and driveways: per the requirements of the City of Bryant
 4. Permit for street cut and repairs shall be furnished by the Contractor.
 5. Contractor shall secure permits and inspections, post necessary bonds, and pay necessary fees.
- B. Temporary Repairs: Per requirements of the governmental agency having jurisdiction and these specifications. Must provide a minimum of a cold mix temporary patch.

1.04 TESTING, OBSERVATION, AND INSPECTION REQUIREMENTS

- A. Testing and inspection is required for pavement repairs in accordance with all local Ordinances, Regulations, or Codes governing the repairs. The inspection of street repairs shall be coordinated with the City of Bryant to ensure compliance with all applicable standards.
- B. Gradation of stone materials shall be performed in accordance with ASTM C136.
- C. The Contractor shall provide at least 24 hours of advance notice for any concrete or asphalt placement.

PART 2 - PRODUCTS**2.01 BASE COURSE MATERIALS**

- A. Base Course: Conform to AHTD Standard Specifications for Highway Construction, Section 303, Class 7.

2.02 ASPHALT MATERIALS

- A. Prime Coat: Medium curing cut-back asphalt; MC-30 or MC070; AASHTO M82; heated and applied within the temperature range 80 degrees F – 150 degrees F.
- B. Hot mix surfacing material shall meet the following requirements: Asphalt Cement Hot Mix Surface Course (1/2-inch) in accordance with Section 407 of the AHTD Standard Specifications for Highway Construction.

PART 3 - EXECUTION

3.01 GENERAL

- A. Asphalt surfaces for pavements, streets, roads, driveways, parking lots and walks shall be repaired with hot mix asphalt. Minimum thickness of asphalt surface replacement shall be 3-inches. The finished surface shall match and shall be level with surrounding pavement.
- B. Before replacing paved surfacing, the existing pavement shall be cut, sawed, or trimmed along straight and vertical lines along each side of the trench.
- C. Temporary repairs (if required) to paved surfaces shall be made with cold mix asphalt to allow access. Final repairs shall be made within 60 days weather permitting. Driveways shall be maintained to allow access during all weather conditions.

3.02 EXCAVATION AND BACKFILL

- A. Excavate and backfill in accordance with Section 2300 Excavation, Backfilling, and Compacting.

3.03 SUBGRADE PREPARATION

- A. Subgrade for asphalt paving improvements shall have all excess material including cold mix asphaltic concrete, soil, organic silty and clayey topsoils and other unsuitable material removed and replaced with approved material.
- B. The base surface on which the replacement material is to be placed shall be finished smooth and any wet material or debris shall be removed.
- C. Fill and compact utility trenches.
- D. Replace soft spots as required.

3.04 BASE COURSE FOR ASPHALTIC PAVING

- A. A concrete slab 6 inches in thickness and reinforced with #4 reinforcement bars placed at 12 inches on center each way shall be poured with the finished top of the slab extending to a point 2 inches below the finished surface. A bituminous tack coat shall then be applied to the concrete surface at a rate of 0.03 to 0.10 gallons per square yard. After proper curing of the tack coat, asphalt concrete hot mix surface course shall be placed with a compacted thickness of 2 inches and rolled with a steel wheeled roller to a minimum density of 92% of maximum density by Modified Proctor method.
- B. Place material on prepared subgrade in accordance with details shown on the Drawings.

1. Spread base course the same day the material is hauled. It shall be thoroughly mixed, either by repeated handling with a blade grader or by harrowing sufficiently to secure a uniform mixture of coarse and fine particles.
 2. Compact base course by systematically rolling and watering as required to obtain a firm, uniform, smooth surface as specified in Division 300 of AHTD Standard Specifications for Highway Construction. Base course shall be compacted in 8-inch lifts. Prime coat shall not be put down until base course is compacted. Apply emulsified tack coat to all existing surfaces.
 3. After acceptance of completed base course, a prime coat shall be uniformly distributed over the prepared base, including vertical edges, at the rate of 0.4 gallons per square yard. Remove surplus asphalt material
- C. Minimum density shall be 95 Percent Standard Proctor (ASTM D698).

3.05 ASPHALT PAVEMENT REPAIRS

- A. Asphalt pavement shall be replaced in accordance with details shown on the Drawings and all materials shall be furnished and installed in accordance with the Arkansas Highway and Transportation Department "Standard Specifications for Highway Construction." Before replacing paved surfacing, the existing pavement shall be cut, sawed, or trimmed along straight and vertical lines. The condition of the backfill and base course material, with special regard to the degree of compaction, may be checked and approved by the City of Bryant before any surfacing is replaced.
- B. All street repairs shall require a "tee" patch, a minimum of 2' wider than the trench width in accordance with the Standard Details.
- C. Trenches shall be backfilled with Class 7 base material compacted to 95% Modified Proctor Density.
- D. Before placement of new surface material, all excess material shall be removed to a minimum depth of nine (9) inches. A minimum of six (6) inches of 4,000 psi concrete shall be placed within three (3) inches of the street surface. Before placing asphalt, the concrete and sides of the cut shall be primed with MC-30 at the rate of 0.3 gallon per square yard.
- E. Minimum thickness of asphalt surface replacement shall be three (3) inches, unless shown otherwise. Hot mix asphalt material shall be delivered to the site in covered vehicles, at 275 deg-F (minimum), and immediately spread to a thickness to match adjacent surfaces after rolling. Compaction shall be by steel-wheel roller to a smooth, uniform surface matching adjacent surfaces.
- F. Paved parking lots disturbed or damaged in the process of construction shall be replaced in kind. Parking lots shall be replaced to same thickness as original but in no case less than 4-inches thick. Joint system in replacement shall be at same style and interval as that in the undisturbed parking lot.
- G. Paved concrete walkways disturbed or damaged in the process of construction shall be replaced in kind. Parking lots and walkway shall be replaced to same width and thickness as original but in no case less than 4-inches thick. Joint system in replacement shall be at same style and interval as that in the undisturbed walkway.
- H. Paved driveways disturbed or damaged in the process of construction shall be replaced in kind. Driveway shall be replaced to same width and thickness as original but in no case shall the asphalt be less than 3-inches thick.

- I. Concrete curbs disturbed or damaged in the process of construction shall be replaced in kind. Curbs shall be replaced to same width and thickness as original. Joint system in replacement shall be at same style and interval as that in the undisturbed curb.
- J. Any settlement or failure of surface replacement shall be repaired or replaced by the Contractor.
- K. All pavement repairs shall be in accordance with the Standard Details.
- L. All pavement markings shall be restored to new conditions per the requirements of the governmental agency having jurisdiction.

3.06 HOT-MIX SURFACING FOR ASPHALTIC PAVING

- A. Plant Mixing and Transporting: Mixing, transportation, and temperature limitations for hot-mix surface course materials shall be in accordance with the requirements of Division 400, Asphalt Pavements of the AHTD Standard Specifications for Highway Construction.
- B. Placing, compacting, and acceptance shall be in accordance with Division 400, Asphalt Pavements of the AHTD Standard Specifications for Highway Construction.
- C. Surface shall be uniform and shall match adjacent surfaces.

3.07 TEMPORARY SURFACING

- A. Comply with the requirements stated above or as otherwise approved to adequately maintain traffic and proper drainage.
- B. The surface shall match the surfaces on each side of the trench and shall be in accordance with applicable state, county, or local requirements.
- C. The Contractor shall maintain all temporary surfaces in good condition until permanent repairs are complete.

3.08 TRAFFIC CONTROL

- A. Whenever traffic flow restrictions of any kind are anticipated, the Contractor will be required to contact the City of Bryant to be given permission to obstruct traffic flow.
- B. Street closing permits must be obtained from proper government agencies.
- C. Suitable construction signs, barricades, lights, etc. shall be erected and the work outlined by adequate lighting at night in order to protect persons from injury and avoid property damage. Provide qualified flagmen to direct traffic while working upon a highway, street, or road over which traffic must pass.
- D. If requested, Contractor will be required to submit a barricade plan to City of Bryant or traffic control agency having jurisdiction. Barricade plan shall be satisfactory to the traffic control agency having jurisdiction.
- E. Maintain traffic and protect the public from all damage to persons and property in accordance with applicable State, City, and County regulations. Maintain and protect access, for vehicle and pedestrian traffic, to and from all properties adjoining or adjacent to those streets affected by operations, and to subject the public to a minimum of delay and inconvenience.
- F. Traffic shall be detoured as required; however, no traffic shall be detoured without prior knowledge and approval of the traffic control agency having jurisdiction. Notify the traffic

control agency having jurisdiction at least 24 hours in advance of the time proposed to detour traffic. No street shall be completely blocked, nor blocked more than one-half at any time without specific authorization.

- G. Closing streets with one access route shall not be acceptable or permitted. One traffic lane shall remain open at any given time. Excavated areas within the traffic lanes of highways, streets, roads and pedestrian walkways shall be backfilled as soon as possible and the area opened to traffic.

END OF SECTION 6000

SECTION 6001**CONCRETE PAVEMENT REPAIR****PART 1 - GENERAL****1.01 WORK INCLUDED**

- A. This section covers the materials and procedures used in the repair of concrete roads, streets, or other public rights-of-way where a water lines, sewer line, or structure is constructed.

1.02 RELATED WORK

- A. Section 2300 - Excavation, Backfilling and Compacting.

1.03 REGULATIONS AND STANDARDS

- A. All permanent repairs of streets, roads, sidewalks, other public rights-of-way, private drives, private parking lots, etc. shall comply with the requirements shown on the Standard Detail Drawings and Tables. The Contractor is responsible for following the requirements of all local Ordinances, Regulations, or Codes governing the repairs to roads, streets, or other public rights of way. In particular:

1. Repair of State Highways: per requirements of the Arkansas State Highway Commission.
2. Repair of county roads: per requirements of the County Roads Department.
3. Repair of City of Bryant streets, sidewalks, and driveways: per the requirements of the City of Bryant
4. Permit for street cut and repairs shall be furnished by the Contractor.
5. Contractor shall secure permits and inspections, post necessary bonds, and pay necessary fees.

- B. Temporary Repairs: Per requirements of the governmental agency having jurisdiction and these specifications. Must provide a minimum of a cold mix temporary patch.

1.04 TESTING, OBSERVATION, AND INSPECTION REQUIREMENTS

- A. Testing and inspection is required for pavement repairs in accordance with all local Ordinances, Regulations, or Codes governing the repairs. The inspection of street repairs shall be coordinated with the City of Bryant to ensure compliance with all applicable standards.
- B. Gradation of stone materials shall be performed in accordance with ASTM C136.
- C. The Contractor shall provide at least 24 hours of advance notice for any concrete or asphalt placement.
- D. Submit complete information regarding concrete mix to Engineer for review in accordance with the requirements of ASTM C94.

PART 2 - PRODUCTS**2.01 BASE COURSE MATERIALS**

- A. Base Course: Conform to AHTD Standard Specifications for Highway Construction, Section 303, Class 7.

2.02 FORMS

- A. Forms shall be constructed prior to placement of any concrete unless otherwise authorized by Engineer.
- B. Forms shall conform to shapes, lines, and dimensions as required to conform to the original shape and dimensions of the structure to be repaired.
- C. Forms shall be sufficiently tight to prevent leakage of mortar. Forms shall be properly braced or tied together so as to maintain position and shape.
- D. Forms shall be constructed of any material with sufficient strength which shall provide the finished work a satisfactory surface; however, metal forms shall not be permitted for concrete which will be exposed on any of the completed work, except upon the specific approval of the Engineer.
- E. Forms shall be constructed in such manner that a smooth concrete surface is produced which matches the existing surfaces on each side.
- F. Forms shall be removed in such a manner as to ensure the complete safety and integrity of the structure. When the structure is supported on shores, the removable floor forms, beams, and girder sides, and column and similar vertical forms may be removed after 96 hours, providing the concrete will not be damaged. Supporting forms or shoring shall not be removed until members have achieved sufficient strength to support their weight and imposed loads safely.
- G. Forms shall be coated with oil before placement of reinforcing steel or concrete. Excessive coating material shall not be permitted to form or stand in puddles in the forms nor allowed in contact with adjacent existing concrete against which fresh concrete will be placed.

2.03 CURB FORMS

- A. 2-inch dressed dimension lumber or metal of equal strength, free from defects that would impair appearance or structural quality of completed curb.
- B. Metal forms: Subject to approval of Engineer.
- C. Short-Radius Forms: 1-inch dressed lumber or plywood.
- D. Curb Face: No horizontal joints in form material closer than 7 inches from top of curb.
- E. Stakes and Bracing Materials: Provide as required to hold forms securely in place.

2.04 SIDEWALK FORMS

- A. 2-inch dressed lumber, straight and free from defects, or standard metal forms.
- B. Short-Radius Forms: 1-inch dressed lumber or plywood.
- C. Stakes and Bracing Materials: Provide as required to hold forms securely in place.

2.05 EXPANSION JOINTS AND JOINT FILLER

- A. Joint Filler - Joint filler shall be pre-molded joint filler of the non-extruding type, 3/4 inch to 1 inch thick conforming to ASTM M33, poured bituminous material conforming to ASTM M18, or rubber based compound conforming to Federal Specification SS-F-336. Joint filler shall be of sufficient dimension to extend through the full depth of the paved surface.
- B. Expansion and contraction joints for sidewalks, streets, driveways, curb and gutter, ditch paving, and protective slabs shall be spaced every 12 feet maximum and shall be placed to match the original joint system for the pavement.

2.06 CONCRETE

- A. Concrete shall be ready mixed concrete conforming to ASTM C94. Concrete shall not contain more than 6 gallons of water per sack of cement, including the water in aggregates, and not less than 6 sacks of cement per cubic yard of concrete.
- B. Cement: Portland Cement conforming to ASTM C150, Type 1
- C. Water used shall be clean and free from injurious amounts of oil, acids, alkalis, salt, organic matter, or other deleterious substances.
- D. Compressive Strength: 4,000 psi at 28 days.
- E. Fine Aggregate: Fine aggregate shall consist of clean, sound, properly graded sand conforming to ASTM Standard C33 uniformly graded. Fine aggregate shall be graded within the following requirements:
 - 1. Total passing the No. 4 Sieve - 95-100% by weight
 - 2. Total passing the No. 16 Sieve - 35-75% by weight
 - 3. Total passing the No. 50 Sieve - 10-25% by weight
 - 4. Total passing the No.100 Sieve - 2-8% by weight
- F. Coarse Aggregate: Coarse aggregate shall consist of crushed stone or gravel having clean, hard, strong, durable non-coated particles with not more than 5% by weight of soft fragments, 1/4% by weight of clay lumps, and 1% by weight of material removed by decantation, except that when the material removed by decantation consists essentially of crushed dirt the maximum amount permitted may be increased to one and one-half percent by weight. Rocks shall conform to ASTM Standard D289.
 - 1. Coarse aggregate may be either of two sizes, 1-1/2 inch and smaller or 3/4 inch and smaller, and shall be graded within the following requirements:
 - a. Maximum size mesh screen (sq. mesh) 0-3% retained by weight
 - b. Half maximum size mesh screen (sq. mesh) 30-65% retained by weight
 - c. No. 4 sieve 94-100% retained by weight
 - 2. Coarse aggregate for exposed aggregate surfaces shall be as follows:
 - a. Total retained on the 1 1/2 inch sieve 0%
 - b. Total retained on the 3/4 inch sieve 25 - 60%

- c. Total retained on the 3/8 inch sieve 70 - 90%
- d. Total retained on the No. 4 inch sieve 95 - 100%
- G. Slump: 3 to 4 inches.
- H. Air Content: Severe Condition. 5.5 percent for 1-½ inch aggregate.
- I. The concrete shall be delivered and placed within 45 minutes after all materials including mixing water have been placed in the mixing drum.

2.07 CURING COMPOUND

- A. Liquid membrane-forming, clear or translucent, suitable for spray application.
- B. Conform to ASTM C309, Type 1.

2.08 REINFORCEMENT

- A. Reinforcement shall be free from rust scale or other coatings that will destroy or reduce the bond.
- B. Reinforcing steel shall be steel of 60,000 psi minimum yield strength, conforming to the following ASTM Standards:
 - 1. A 615, Standard Specification for Deformed Billet-Steel Bars for Concrete Reinforcement
 - 2. A 616, Standard Specification for Rail-Steel Deformed Bars for Concrete Reinforcement
 - 3. A 617, Standard Specification for Axle-Steel Deformed Bars for Concrete Reinforcement
 - 4. A 185, Specification for Welded Steel Wire Fabric for Concrete Reinforcement
- C. All reinforcing steel bars #3 (3/8" diameter) or larger shall be deformed bars conforming to these specifications. Plain (non-deformed) bars larger than 1/4" diameter shall not be used for reinforcing.
- D. The supplier of reinforcing steel shall furnish certification of compliance with these specifications.
- E. Reinforcement shall be shop bent, unless otherwise permitted by the Engineer. Reinforcement partially embedded in concrete shall not be bent.
- F. Reinforcement shall be accurately placed according to the Drawings or as specified herein and adequately secured in position by concrete, metal, or other approved chairs, spacers, or ties.
- G. Reinforcement shall not be welded unless specifically permitted by the Engineer.
- H. Reinforcement shall be protected by the thickness of concrete as shown on the Drawings. Where dimension are not shown, the thickness of concrete over the reinforcement shall be as follows:
 - 1. Where concrete is deposited against the ground without the use of forms, not less than 3 inches, except wire mesh reinforcement for concrete slabs which may be within 1 1/2 inches of the ground.

2. Where concrete is to be exposed to the weather or to the ground but placed in forms, in slabs and wall not exposed to the ground or to the weather not less than 2 inches.
 3. In all other cases not less than 2 inches.
- I. Reinforcement for concrete streets, driveways, and parking lots shall be #6 bars placed at 6 inches on center perpendicular to the trench and #4 bars placed at 6 inches on center parallel to the trench.
 - J. Reinforcement for curb and gutter shall consist of #3 bars spaced at 6 inch centers longitudinally with #4 transverse tie bars spaced at 2 foot centers. The bars shall be firmly held in place by wiring bars together. Bar chairs or other suitable steel devices shall be used to support the reinforcement at a level 3 inches above the bottom of the concrete.
 - K. Reinforcement for sidewalks, ditch paving, and slope protection shall consist of 6 inch x 6 inch mesh, #6 for driveways and #9 for ditch paving, slope protection and sidewalks.

2.09 ACCEPTANCE OF MATERIALS

- A. Materials shall be subject to inspection for suitability by the City of Bryant prior to or during incorporation into the work.

PART 3 - EXECUTION

3.01 GENERAL

- A. Concrete pavement shall be replaced in accordance with details shown on the Drawings and all materials shall be furnished and installed in accordance with the Arkansas Highway and Transportation Department "Standard Specifications for Highway Construction." Before replacing paved surfacing, the existing pavement shall be cut, sawed, or trimmed along straight and vertical lines. The condition of the backfill and base course material, with special regard to the degree of compaction, may be checked and approved by the City of Bryant before any surfacing is replaced.
- B. All street repairs shall require a "tee" patch, a minimum of 2' wider than the trench width in accordance with the Standard Details.
- C. Trenches shall be backfilled with Class 7 base material compacted to 95% Modified Proctor Density.
- D. Before placement of concrete street material, all excess material shall be removed to a minimum depth of six (6) inches. A minimum of six (6) inches of 4,000 psi concrete shall be placed to match the line and grade of existing street surface.
- E. After removal of forms and finishing, backfill shall be placed around structures and thoroughly compacted.
- F. Paved walkways disturbed or damaged in the process of construction shall be replaced in kind. Walkway shall be replaced to same width and thickness as original but in no case less than 4-inches thick. Joint system in replacement shall be at same style and interval as that in the undisturbed walkway.
- G. Paved driveways disturbed or damaged in the process of construction shall be replaced in kind. Driveway shall be replaced to same width and thickness as original but in no case less than 6-

inches thick. Joint system in replacement shall be at same style and interval as that in the undisturbed driveway.

- H. Paved parking lots disturbed or damaged in the process of construction shall be replaced in kind. Parking lots shall be replaced to same thickness as original but in no case less than 6-inches thick. Joint system in replacement shall be at same style and interval as that in the undisturbed parking lot.
- I. Concrete curbs disturbed or damaged in the process of construction shall be replaced in kind. Curbs shall be replaced to same width and thickness as original. Joint system in replacement shall be at same style and interval as that in the undisturbed curb.
- J. All pavement repairs shall be in accordance with the Standard Details.
- K. All pavement markings shall be restored to new conditions per the requirements of the governmental agency having jurisdiction.

3.02 EXCAVATION AND BACKFILL

- A. Excavate and backfill in accordance with Section 2300 Excavation, Backfilling, and Compacting.

3.03 PREPARATION OF SUBGRADE

- A. Bring the areas where pavement, curbs, and sidewalks are to be constructed to required grade on undisturbed ground and compact by sprinkling and rolling or mechanical tamping.
- B. As depressions occur, refill with crushed stone base course material and recompact until the surface is at the proper grade.
- C. Compact subgrade on fill to 95 percent of maximum density at optimum moisture content as determined by ASTM D698 Standard Proctor Density.

3.04 PLACING CRUSHED STONE BASE

- A. After subgrade for sidewalks and curbs is compacted and at proper grade, spread at least 4 inches of crushed stone base course material and compact to at least 95 percent of maximum density as determined by ASTM D698 Standard Proctor Density.
- B. Sprinkle with water and compact by rolling or other method.
- C. Top of compact granular fill shall be at proper level to receive concrete after taking slab thickness and desired finished grade into account.

3.05 SETTING FORMS

- A. Construct forms to the shape, lines, grades, and dimensions called for on the Drawings, or match shape, lines, grades, and dimensions of cut curbs.
- B. Stake wood or metal forms securely in place, true to line and grade.
- C. Brace forms to prevent change of shape or movement in any direction resulting from the weight of the concrete during placement.

- D. Construct short-radius curved forms to exact radius.
- E. Tops of forms shall not depart from grade line more than 1/8 inch when checked with a 10 foot straightedge.
- F. Alignment of straight sections shall not vary more than 1/8 inch in 10 feet.
- G. Forms shall be cleaned and oiled thoroughly after each use and before concrete is placed.

3.06 PLACING CONCRETE

- A. All placement of concrete shall be in the presence of the Engineer or his representative. The Contractor may be required to remove, without compensation, any concrete placed in the absence of the Engineer or his representative.
- B. Equipment for chuting, pumping and pneumatically conveying concrete shall be of such size and design as to ensure a practically continuous flow of concrete at the delivery end without separation of materials. All concrete in walls and columns shall be poured through tremies unless otherwise permitted by the Engineer. The free fall of concrete shall be held to a minimum.
- C. Concrete shall be deposited as nearly as practicable in its final position to avoid segregation due to rehandling or flowing. The placing of concrete shall be carried on at such a rate that concrete is at all times plastic and flows readily into the spaces between the bars. No concrete that has been contaminated by foreign material shall be used.
- D. Once placement has started, it shall be carried on as a continuous operation until placement of the panel or section is complete. When construction joints are necessary, they shall be constructed in accordance with these specifications.
- E. Concrete shall be placed and vibrated in such a manner as to prevent coarse aggregate to separate from mortar, that no rock pockets are left, that the concrete flows readily around the steel reinforcement and into the extremities of the forms. Free water shall not be present on the surface of the concrete. All concrete paving shall be poured and vibrated with mechanical vibration equipment.
- F. Water shall be removed from the place of deposit before concrete is placed. Before depositing concrete on or against concrete which has taken its initial set, the surface of the hardened concrete shall be broken off down to coarse aggregate and wire brushed to remove foreign matter and laitance. A layer of grout of the same cement-sand ratio as the concrete without coarse aggregate shall be placed to a thickness of one to two inches on the brushed surface after which the new concrete shall be placed immediately.

3.07 CURB CONSTRUCTION

- A. Construct curbs to line and grade shown or established by the Engineer, and conform to the details shown on Drawings. The cross section of the curb and gutter shall conform to that of adjacent sections.
- B. Place, process, finish, and cure concrete in conformance with this Section and the applicable requirements of ACI 614. Wherever requirements differ, the more stringent shall govern.

- C. Cast in uniform lengths of approximately 10 to 20 feet, except at closures where lengths may not be less than 6 feet.
- D. Placement of Preformed Asphalt-Impregnated Expansion Joints:
 - 1. At intervals not exceeding 40 feet.
 - 2. Beginning and end of curved portions of the curb.
 - 3. Connections to existing curbs.
- E. Contraction Joints:
 - 1. Place at intervals not exceeding 10 feet.
 - 2. Open type joint.
 - 3. Provide by inserting thin, oiled steel sheet vertically in fresh concrete to force coarse aggregate away from joint.
 - 4. Steel sheet shall be inserted the full depth of the curb.
 - 5. After initial set has occurred in the concrete and prior to removing the front curb form, steel sheet shall be removed with a sawing motion.
- F. As soon as concrete has set sufficiently to support its own weight, remove the front form and finish all exposed surfaces.
 - 1. Finish top of curb with a steel trowel and a broom to produce a uniform finish to match that of adjacent sections.
 - 2. Finish edges with a steel edging tool.
 - 3. Rub formed faces with burlap sack or similar device to produce a uniformly textured surface, free from form marks, honeycomb, and other defects.
 - 4. The curb and gutter shall be grooved with an approved grooving tool at intervals equal to those of adjacent sections.
- G. Curing:
 - 1. Upon completion of finishing, apply approved curing compound to exposed surfaces of curb.
 - 2. Curing shall continue for a minimum of 10 days.
- H. Backfilling Curb: Upon completion of curing period, but not before 7 days has elapsed since pouring the concrete, backfill the curb as specified in Section 312333 Trench Excavation, Backfill, and Compacting.
- I. Adjusting:
 - 1. Finished curb shall present a uniform appearance for both grade and alignment.
 - 2. Remove curb sections showing abrupt changes in alignment or grade or that are more than 1/4 inch away from location as staked or that are defective for any reason.
 - 3. Construct new curb at Contractor's expense.

3.08 SIDEWALK CONSTRUCTION

- A. Thickness of sidewalks shall a minimum of 4 inches or as shown on the Drawings. Concrete shall be placed true to grade to ensure that ponding of water will not occur.

- B. Place, process, finish, and cure concrete in conformance with this Section and the applicable requirements of ACI 614. Where the requirements differ, the more stringent shall govern.
- C. Placement of Preformed Asphalt Expansion Joints:
 - 1. Where sidewalk ends.
 - 2. Around posts, poles, or other objects protruding through the sidewalk.
 - 3. At maximum intervals of 15 feet.
- D. Contraction Joints:
 - 1. Provide transversely to walk.
 - 2. Saw cut weakened plane joints shall be straight and at right angles to the surface of the walk. Saw cuts shall be constructed midway between expansion joints to a depth of 25 percent of slab thickness. Saw cuts shall be performed within 24 hours of placement.
- E. Reinforcing: 6 by 6 inch, W1.4xW1.4 mesh shall be installed one third the slab thickness below the top surface.
- F. Finish:
 - 1. Broom surface with fine hair broom at right angles to length of walk and tool at edges, joints, and markings. Finish shall match that of adjacent surfaces.
 - 2. Walks shall be scored at no less than 5-foot intervals and within 24 hours of concrete placement.
- G. Curing:
 - 1. Upon completion of finishing, apply an approved curing compound to exposed surfaces.
 - 2. Protect sidewalks from damage for period of 10 days.

3.09 FLAT SURFACES

- A. Concrete shall be deposited and leveled so that the surface conforms to the line, grade and finish required to match adjacent surfaces.
- B. Exposed aggregate finish – Scrubbed finish shall be produced on green concrete. The surface shall be thoroughly wetted and scrubbed with stiff fiber or wire brushed, using water freely, until the surface film of mortar is removed and the aggregate is uniformly exposed. The surface shall then be rinsed with clean water. If portions of the surface have become too hard to scrub in equal relief, dilute hydrochloric acid (commercial muriatic acid diluted with 4 to 10 parts water) shall be used after the concrete is at least two weeks old to facilitate the scrubbing. The acid shall be removed within 15 minutes from the finished surface with clean water. This operation may be facilitated by casting the concrete against form faces which have been coated with a chemical retarder to keep the mortar adjacent to the form from setting. Every effort shall be exerted to assure that the new surface matches any existing adjacent surfaces.
- C. Protect flat surfaces from damage for period of 10 days.

3.10 COLD WEATHER REQUIREMENTS

- A. Concrete shall not be placed when the ambient temperature is below 40 degrees F, or when the concrete is likely to be subjected to freezing temperatures before final set has occurred. Concrete footings or slabs shall not be placed over frozen ground. The temperature of the concrete when

placed shall not be less than 45 degrees F. Suitable means shall be provided for maintaining the concrete at a temperature of 45 degrees F for not less than 96 hours after placing.

- B. Any concrete damaged by freezing shall be removed and replaced at the expense of the Contractor.

3.11 HOT WEATHER REQUIREMENTS

- A. Suitable precautions shall be taken in hot weather to avoid drying of the concrete prior to finishing operations.
- B. Concrete deposited in hot weather shall not have a placing temperature that will cause difficulty from loss of slump, flash set, or cold joints. Concrete temperatures shall be less than 90 degrees F.

3.12 TEMPORARY SURFACING

- A. Comply with the requirements stated above or as otherwise approved to adequately maintain traffic and proper drainage.
- B. Unless permanent repairs to paved surfaces will be repaired within two (2) days after backfilling the trench, the Contractor shall place suitable asphalt material in the trench. This shall apply to driveways, sidewalks, parking lots, or other paved surface whenever the backfill will not adequately support vehicular traffic, whenever dust from the trench creates a nuisance, or whenever the trench is a hazard.
- C. The surface shall match the surfaces on each side of the trench and shall be in accordance with applicable state, county, or local requirements.
- D. The Contractor shall maintain all temporary surfaces in good condition until permanent repairs are complete.
- E. Detours shall have a gravel, crushed stone, or asphalt surface. Dust shall be controlled by the application of asphalt or water.

3.13 TRAFFIC CONTROL

- A. Whenever traffic flow restrictions of any kind are anticipated, the Contractor will be required to contact the City of Bryant to be given permission to obstruct traffic flow.
- B. Street closing permits must be obtained from proper government agencies.
- C. Suitable construction signs, barricades, lights, etc. shall be erected and the work outlined by adequate lighting at night in order to protect persons from injury and avoid property damage. Provide qualified flagmen to direct traffic while working upon a highway, street, or road over which traffic must pass.
- D. If requested, Contractor will be required to submit a barricade plan to City of Bryant or traffic control agency having jurisdiction. Barricade plan shall be satisfactory to the traffic control agency having jurisdiction.
- E. Maintain traffic and protect the public from all damage to persons and property in accordance with applicable State, City, and County regulations. Maintain and protect access, for vehicle and pedestrian traffic, to and from all properties adjoining or adjacent to those streets affected by operations, and to subject the public to a minimum of delay and inconvenience.

- F. Traffic shall be detoured as required; however, no traffic shall be detoured without prior knowledge and approval of the traffic control agency having jurisdiction. Notify the traffic control agency having jurisdiction at least 24 hours in advance of the time proposed to detour traffic. No street shall be completely blocked, nor blocked more than one-half at any time without specific authorization.
- G. Closing streets with one access route shall not be acceptable or permitted. One traffic lane shall remain open at any given time. Excavated areas within the traffic lanes of highways, streets, roads and pedestrian walkways shall be backfilled as soon as possible and the area opened to traffic.

END OF SECTION 6001

SECTION 6002**GRAVEL SURFACING REPAIR****PART 1 - GENERAL****1.01 WORK INCLUDED**

- A. This section covers the materials and procedures used in the repair of gravel roads, streets, or other public rights-of-way where a water lines, sewer line, or structure is constructed.

1.02 RELATED WORK

- A. Section 2300 - Excavation, Backfilling and Compacting.

1.03 REGULATIONS AND STANDARDS

- A. All permanent repairs of gravel streets, roads, sidewalks, other public rights-of-way, private drives, private parking lots, etc. shall comply with the requirements shown on the Standard Detail Drawings and Tables. The Contractor is responsible for following the requirements of all local Ordinances, Regulations, or Codes governing the repairs to roads, streets, or other public rights of way. In particular:
 - 1. Repair of State Highways: per requirements of the Arkansas State Highway Commission.
 - 2. Repair of county roads: per requirements of the County Roads Department.
 - 3. Repair of City of Bryant streets, sidewalks, and driveways: per the requirements of the City of Bryant
 - 4. Permit for street cut and repairs shall be furnished by the Contractor.
 - 5. Contractor shall secure permits and inspections, post necessary bonds, and pay necessary fees.

1.04 TESTING, OBSERVATION, AND INSPECTION REQUIREMENTS

- A. Testing and inspection is required for pavement repairs in accordance with all local Ordinances, Regulations, or Codes governing the repairs. The inspection of street repairs shall be coordinated with the City of Bryant to ensure compliance with all applicable standards.
- B. Gradation of stone materials shall be performed in accordance with ASTM C136.
- C. The Contractor shall provide at least 24 hours of advance notice for any concrete or asphalt placement.

PART 2 - PRODUCTS**2.01 BASE COURSE MATERIALS**

- A. Base Course: Conform to AHTD Standard Specifications for Highway Construction, Section 303, Class 7.
- B. Free from objectionable, deleterious, or other injurious matter.

PART 3 - EXECUTION

3.01 PLACING GRAVEL SURFACING

- A. Trenches shall be backfilled with Class 7 base material compacted to 95% of maximum density at optimum moisture content as determined by ASTM D698 Standard Proctor Density.
- B. Gravel surfacing shall be replaced to at least the compacted thickness of the original surface. All excavated material shall be removed from gravel surfaces affected by construction and sufficient new gravel material shall be placed to restore the original surfaced area. Minimum gravel thickness shall be six (6) inches.
- C. For compacted depths exceeding 8 inches, place material in multiple courses of equal depth which do not exceed 8 inches.
- D. Compact each course with mechanical compaction equipment. Compaction with wheel of backhoe or trackhoe is not acceptable. Compact to 95% Modified Proctor Density.
- E. Finish grade to provide smooth transition with surrounding gravel. Avoid leaving any humps or ruts.
- F. Repair settling as required.

3.02 TRAFFIC CONTROL

- A. Whenever traffic flow restrictions of any kind are anticipated, the Contractor will be required to contact the City of Bryant to be given permission to obstruct traffic flow.
- B. Street closing permits must be obtained from proper government agencies.
- C. Suitable construction signs, barricades, lights, etc. shall be erected and the work outlined by adequate lighting at night in order to protect persons from injury and avoid property damage. Provide qualified flagmen to direct traffic while working upon a highway, street, or road over which traffic must pass.
- D. If requested, Contractor will be required to submit a barricade plan to City of Bryant or traffic control agency having jurisdiction. Barricade plan shall be satisfactory to the traffic control agency having jurisdiction.
- E. Maintain traffic and protect the public from all damage to persons and property in accordance with applicable State, City, and County regulations. Maintain and protect access, for vehicle and pedestrian traffic, to and from all properties adjoining or adjacent to those streets affected by operations, and to subject the public to a minimum of delay and inconvenience.
- F. Traffic shall be detoured as required; however, no traffic shall be detoured without prior knowledge and approval of the traffic control agency having jurisdiction. Notify the traffic control agency having jurisdiction at least 24 hours in advance of the time proposed to detour traffic. No street shall be completely blocked, nor blocked more than one-half at any time without specific authorization.
- G. Closing streets with one access route shall not be acceptable or permitted. One traffic lane shall remain open at any given time. Excavated areas within the traffic lanes of highways, streets, roads and pedestrian walkways shall be backfilled as soon as possible and the area opened to traffic.

END OF SECTION 6002

SECTION 6100

LAWN AND GRASS RESTORATION

PART 1 - GENERAL

1.01 WORK INCLUDED

- A. This Section covers the replacement of sod in lawns disturbed by the construction.
- B. Consists of furnishing and applying fertilizer, seed, mulch cover, and water at all other locations disturbed by the construction.
- C. Maintenance service.

1.02 RELATED WORK

- A. Section 2300 - Excavation, Backfilling, and Compacting

1.03 SCOPE OF WORK

- A. This Section covers the furnishing and placing of sod to form solid mats on areas shown on the Drawings (generally lawns or commercial green spaces) or seed and mulch all other areas disturbed by the Contractor.
- B. It covers the furnishing and applying of water.
- C. It covers the furnishing and placing of four (4) inches of topsoil on all areas disturbed during construction.
- D. It covers the furnishing and placing of fertilizer.
- E. All work shall be in accordance with details shown on the Drawings and within these Specifications.
- F. The Contractor is responsible for following the requirements of all local Ordinances, Regulations, or Codes governing re-vegetation and slope stabilization.

1.04 WARRANTY

- A. Provide one year warranty from date of final acceptance.
- B. Replace areas found dead, or not in a healthy growing condition.

PART 2 - PRODUCTS

2.01 TOPSOIL

- A. Topsoil shall be reasonably free from subsoil, clay, lumps, brush, objectionable weeds and/or other litter and shall be free from roots and toxic substances or other material or substances that might be harmful to plant growth or be a hindrance to grading, planting and maintenance operations.

2.02 FERTILIZER

- A. Fertilizer shall be a standard commercial product complying with State and Federal laws and with the requirements issued by proper authorities.
- B. Fertilizer shall be delivered to the site in the manufacturer's original container, on which shall be plainly marked the manufacturer's name and the guaranteed chemical analysis.
- C. Except as noted in the following sentence, fertilizer shall contain not less than the percentages by weight of ingredients as follows:

Nitrogen	- 13 percent
Phosphorus, P205	- 13 percent
Potash, K2	- 13 percent

Other 1:1:1 ratio fertilizers may be used, provided the available plant food remains the same as herein specified.
- D. All fertilizer shall be solid and shall be in a condition which will permit proper distribution.

2.03 SOD

- A. Solid sod shall be cut from well-established viable Bermuda, Zoysia or St. Augustine grass. Sod type shall match that established in the disturbed areas.

2.04 SEED

- A. Contractor shall apply seed mixture appropriate for the season and disturbed area.
- B. Contractor shall apply a mixture of various annuals and perennials to provide overlapping times of seasonal peak vegetative cover. Seeding shall only be done just prior to the vegetation's peak season for best results. Seeding shall be used when there is sufficient time in the season to ensure adequate vegetation establishment and erosion control.
- C. To optimize soil stabilization, Contractor shall utilize a nurse crop of quick growing annuals within a mix of perennials appropriate for the season. The nurse crop germinates and grows rapidly, holding the soil until the slower-growing perennial seedlings become established. Permanent vegetation shall not be considered established until a ground cover of perennial vegetation is achieved that is uniform and mature enough to survive and be of sufficient density to preclude erosion.
- D. Contractor shall conduct seeding activities to achieve stabilization that are generally congruent with the following schedule:

Dormant Cold Season Temporary Stabilization (November 1 – February 28)

Seeding at this time of the year typically does not produce successful results, as cold temperatures inhibit seed germination. Contractor shall be responsible for achieving temporary stabilization via mulching, erosion control blankets, matting, compost, and/or other appropriate structural/nonstructural methods for temporary stabilization until seasonal weather conditions become more conducive to establishment of permanent perennial vegetative cover. Fertilizers shall be added at this time in preparation for seeding. Contractor shall be responsible for achieving temporary stabilization at all areas that are unstable and subject to erosion. Contractor shall apply temporary seeding, as follows:

Dormant Cool Season Temporary Cover Crop Seed Mix (November 1 – February 28)

Plant Species	Growth Season/ Life Cycle	Seeding Rate
Winter Rye (<i>Secale Cereale</i>)	cool season annual	75 lb/ac
Perennial Ryegrass (<i>Lolium perenne</i>)	cool season perennial	75 lb/ac

Pre Warm Season (Spring) Seeding (March 1 – May 31)

As the growing season approaches, Contractor shall apply a mix of quick germinating cool season species combined with warm season species listed below. The cool season species will serve to hold the soil until warmer weather arrives stimulating the warm season species to germinate.

Pre Warm Season (Spring) Seed Mix (March 1 – May 31)

Plant Species	Growth Season/ Life Cycle	Seeding Rate
Oats (<i>Avena sativa</i>)	cool season annual	20 lb/ac
Perennial Ryegrass (<i>Lolium perenne</i>)	cool season perennial	20 lb/ac
White clover (<i>Trifolium repens</i>)*	cool season perennial	20 lb/ac
Korean(Kobe)lespedeza(<i>Kummerowia stipulacea</i>)*	warm season annual	20 lb/ac
Bermuda (<i>Cynodon dactylon</i>)	warm season perennial	30 lbs/ac
Bahiagrass (<i>Paspalum notatum</i>)	warm season perennial	30 lbs/ac
Weeping love grass (<i>Eragrostis curvula</i>)	warm season perennial	30 lbs/ac

*All legume seed must be properly inoculated with appropriate inoculant.

Warm Season Seeding (June 1 – August 31)

In the midst of the growing season, Contractor shall apply a mix of warm season annuals and perennials, as follows:

Warm Season Seed Mix (June 1 – August 31)

Plant Species	Growth Season/ Life Cycle	Seeding Rate
Sudan grass (<i>Sorghum bicolor</i>)	warm season annual	20 lb/ac
Alyce clover (<i>Alysicarpus ovalifolius</i>)	warm season annual	20 lb/ac
Brown-top millet (<i>Panicum ramosum</i>)	warm season annual	20 lb/ac
Bermuda (<i>Cynodon dactylon</i>)	warm season perennial	25 lbs/ac
Bahiagrass (<i>Paspalum notatum</i>)	warm season perennial	25 lbs/ac
Weeping love grass (<i>Eragrostis curvula</i>)	warm season perennial	25 lbs/ac
Buffalo grass (<i>Bouteloua dactyloides</i>)	warm season perennial	25 lbs/ac

Late Season Seeding (September 1 – October 31)

During late summer to early fall, Contractor shall apply the following mix:

Late Season Seed Mix (September 1 – October 31)

Plant Species	Growth Cycle/ Life Cycle	Seeding Rate
Oats (<i>Avena sativa</i>)	cool season annual	30 lb/ac
Winter rye (<i>Secale cereale</i>)	cool season annual	30 lb/ac
White clover (<i>Trifolium repens</i>)	cool season perennial	25 lb/ac
Perennial Ryegrass (<i>Lolium perenne</i>)	cool season perennial	50 lb/ac
Virginia wildrye (<i>Elymus virginicus</i>)	cool season perennial	25 lb/ac

*All legume seed must be properly inoculated with appropriate inoculant.

- E. Contractor has option of adding warm season perennials to Late Season Seed Mix (September 1 – October 31) and/or Dormant Cool Season Temporary Cover Crop Seed Mix (November 1 –

February 28) or seeding with warm season perennials during other seeding periods. This is to be determined on a site-specific basis. Contractor shall confer with City of Bryant prior to seeding activities to determine specific seed mix.

- F. Contractor shall submit all labels/tags from seed bags and seed purchase invoices to the City of Bryant.

2.05 MULCH

- A. Mulching shall be used in conjunction with both temporary and permanent seeding practices to enhance their success by providing erosion protection prior to the onset of vegetative growth. Straw mulching shall be of oat, wheat, or rice straw mulch. Hay mulch shall be prairie grass, Bermuda grass, or other hay as approved. Mulch shall be dry and reasonably free from Johnson grass or other noxious weeds, and shall not be excessively brittle or in an advanced state of decomposition. All material will be inspected and approved prior to use.

2.06 LIME

- A. Lime shall be agricultural grade ground limestone or equivalent as approved by the Engineer.

2.07 WATER

- B. Water shall be free from any substances, in solution or in suspension, which would inhibit the rapid growth of grass.
- C. Contractor shall be responsible for any fees and water use charges as may be charged to the Contractor by the City of Bryant.

PART 3 - EXECUTION

3.01 SEQUENCE

- A. Unless otherwise requested in writing and acceptable to the Engineer, the sequence of work for seeding shall be:
 1. Finish grading
 2. Application of lime and fertilizer
 3. Seeding
 4. Firming and cultipacking
 5. Mulching seeded areas
 6. Vibratory rolling
 7. Cleanup
 8. Protection
 9. Maintenance
 10. Final acceptance
- B. If trenching operations do not commence within 30 days after clearing and grubbing, the disturbed area shall be seeded.

3.02 FINISH GRADING

- A. After trench backfilling and compacting activities have been completed, all areas which have been disturbed or damaged by construction operations shall be brought to original grade, or if directed by the Engineer, graded to secure effective drainage. Unless otherwise indicated, a slope of at least 1 percent shall be provided. All ruts, deep tracks, dead furrows and ridges shall be eliminated.

- B. In areas of maintained lawn grass, 6 inches of topsoil shall be placed. Imported topsoil may be substituted for stockpiled surface material. Topsoil shall be of a quality at least equal to the existing surface material in adjacent areas, free from trash, debris, and well suited to support plant growth.
- C. Maintain finish grade until final acceptance. Repair damage caused by work operations or erosion. Add imported topsoil, if required.

3.03 CLEARING

- A. Prior to seeding, vegetation that may interfere with operations shall be mowed, grubbed, and raked. The collected material shall be removed from the site. The surface shall be cleared of stumps, loose surface rocks, roots, cable, wire, and other materials that might hinder the work or subsequent maintenance.

3.04 FERTILIZER AND LIME APPLICATION

- A. Fertilizers shall be applied at appropriate agronomic rate. If necessary to achieve final stabilization, fertilizer shall be applied at a minimum rate of 250 pounds per acre (0.0057 pounds per square foot) in advance of tilling/seedbed preparation operations. When soil samples are not practical, fertilizer shall consist of 13-13-13 (nitrogen, phosphorus, and potassium content). Lime shall be applied at a rate of one tone per acre or as recommended by soil test. The fertilizer distributor box shall be equipped with baffle plates to prevent downward movement of fertilizer when operating on a slope. The fertilizer shall be raked in and thoroughly mixed with the soil to a depth of approximately 2 inches prior to the application of seed or mulch.
- B. Fertilizer shall be uniformly incorporated into the soil or combined with seed in the hydro-seeding operation.

3.05 APPLICATION OF SEED

- A. Areas to be seeded shall be dressed to natural shape.
- B. The Contractor shall obtain an approved topsoil from any available source and place uniformly on the designated areas and spread evenly to a minimum thickness of four (4) inches. Irregularities in the surface shall be corrected so as to prevent formation of depressions where water will stand. **TOPSOIL SHALL NOT BE PLACED WHEN THE SUBGRADE IS FROZEN, EXCESSIVELY WET, OR IN A CONDITION DETRIMENTAL TO THE PROPOSED PLANTING AND PROPER GRADING.**
- C. Broadcast sowing of seed may be accomplished by hand seeders or by approved power equipment. Either method shall result in uniform distribution and no work shall be performed during high winds. The area seeded shall be lightly firmed with a cultipacker immediately after broadcast.
- D. The contractor shall water and maintain seeded areas from time of completion until final acceptance of the project.
- E. The contractor shall be responsible for establishing ground cover on all disturbed areas. Repeated seeding shall be required if necessary throughout the warranty period.

3.06 HYDROSEEDING

- A. Hydroseeding shall be carried out by means of a proper hydroseeder where approved slurry of seeds, mulch, fertilizers, binders, and organic matter are sprayed on the prepared soil surface.

3.08 APPLICATION OF MULCH

- A. Mulching shall be spread in a uniform continuous blanket, at a rate of 1 to 3 tons per acre (air dried weight) or to a uniform 2-inch depth. Mulch shall be spread by hand or by an approved blower type mulch spreader whereby the application of mulch cover and tackifier may be combined into one operation. If this method is used, no change in application rates will be allowed. Care shall be taken to remove all wire and/or twine from baled hay/straw when the control structures are removed from the site. Mulch shall be anchored in the soil to a depth of two to three inches to form a soil-binding mulch to prevent loss or bunching, or held in place with a tackifier.

3.09 ROLLING

- A. All seeded areas for established lawns and yards shall be rolled with a drum roller to achieve a smooth surface.

3.09 PROTECTION

- A. Seeded areas shall be protected against traffic. If necessary, barricades or warning signs shall be erected. Such protective devices shall be maintained until acceptance of the work as specified herein.

3.03 SOD PLACEMENT

- A. In this paragraph, "Solid Sod" is interchangeable with the word "sod."
- B. Solid sod or topsoil shall not be placed until all other items of work are complete.
- C. Prior to placing the sod and topsoil in the areas designated, the ground surface shall be cleared of materials greater than ¾" that might hinder proper grading, tillage, or subsequent maintenance operations such as stumps, stones, roots, cable, wire, grade stakes, etc., and brought to four (4) inches below the finished grade. The areas shall then be thoroughly tilled to a depth of at least three (3) inches by plowing, disking, harrowing or other acceptable means. Lightly rake to provide a smooth, uniform and fine surface texture. Remove ridges and fill depressions as required to drain.
- D. The Contractor shall then obtain an approved topsoil from any available source and place uniformly on the designated areas and spread evenly to a minimum thickness of four (4) inches. Irregularities in the surface shall be corrected so as to prevent formation of depressions where water will stand. TOPSOIL SHALL NOT BE PLACED WHEN THE SUBGRADE IS FROZEN, EXCESSIVELY WET, OR IN A CONDITION DETRIMENTAL TO THE PROPOSED PLANTING AND PROPER GRADING.
- E. After the topsoil has been spread and graded, the surface shall be cleared of stones, stumps or other objects that might hinder planting or maintenance preparations. Paved areas over which hauling operations are conducted shall be kept clean.
- F. Where any portion of the surface becomes gullied or otherwise damaged, the affected areas shall be repaired to the aforementioned condition.
- G. Areas to be sodded shall be shaped in such manner that they will, after placement of sod, conform to the typical sections. Lay sod uniformly, evenly, and parallel to the finished contour.
- H. Minimize traffic on newly laid sod during installation. Provide plank or wood sheets as may be required to protect sod already laid during sodding operations.
- I. Lay each strip with tightly-fitted joints against each other without voids. Do not overlap edges. Joints at the ends of sod strips shall be staggered with adjacent strips of sod.

- J. Finish sod edges at walks, curbs, planting, mulch edges, and other vertical surface by cutting neatly and fitting tightly to edge and line.
- K. Sod mat to be approximately one inch below finished height of walks, pavement, curbs, etc. Any sod not conforming to this requirement will be removed, the subgrade adjusted, and the sod relaid.
- L. Where new sod joins existing lawns, cut straight and neatly into existing lawn and level subgrade to allow height to match.
- M. Soil shall be firmed or heeled in along the edges of the sodded areas.
- N. Stake sod on the slope ratio of 1 on 2 or steeper with minimum of two 8 inch stakes per square yard.
- O. After all sod is laid and thoroughly watered, roll all sodded areas (except staked sod), either with a small mechanical or hand roller, sufficiently to set or press sod into soil.

3.04 WATERING

- A. Prior to placement of seed or sod, areas shall be sprinkled with water sufficiently to make them moist, but not muddy. The initial application of water may be omitted if the area is sufficient moist from rainfall.
- B. Immediately following the placing and tamping of sod, the covered area shall be wetted thoroughly. Subsequent applications of water shall be as required.
- C. Immediately following the application of the mulch cover for seeding, water shall be applied in sufficient quantity to thoroughly moisten the soil to the depth of pulverization and then as necessary to germinate the seed and maintain growth.

3.05 MAINTENANCE

- A. For the first two (2) weeks following the placing of the sod, all sodded areas shall be thoroughly watered daily, through the use on an on-site watering system.
- B. Continue maintenance until sodded areas are established with sod knitted in place. Maintenance period shall be a minimum of 28 days, or to final acceptance.
- C. Maintenance of sodded areas shall include watering, weeding, mowing to a two to two and one half (2-2 1/2") inches height after growth has exceeded three (3") inches and prior to a four (4") growth, and replacement and installation of sod as originally specified for sodded areas failing to survive. Clippings from mowing which mat on the grass are to be removed.
- D. Water all sodded areas during maintenance period as necessary to maintain sod and soil moisture, supplement rainfall, to promote growth, proper rooting to ensure sod survival and to prevent dormancy.
- E. All seeded areas shall be maintained and watered by the Contractor until acceptance of the work as specified herein. Maintenance shall include reseeding, watering, repair, or erosion damage, and maintenance of mulch.
- F. Replanting: Prior to acceptance, seeded areas that show signs of substantial desiccation, as evidence by loss of color and distinct yellowing or by lack of germination, shall be considered

failed and shall be reseeded and continue to be reseeded until acceptable cover is obtained. Replanting operations shall be as originally specified.

- G. Maintenance of Grades: Original grades of seeded areas shall be maintained after commencement of planting operations and until acceptance. Any damage to the finished surface from construction operations shall be repaired within a reasonable time. In the event erosion occurs from rainfall, such damage shall be repaired within a reasonable time. Ruts, ridges, tracks, and other surface irregularities shall be corrected, and re-seeded where required.
- H. Maintenance of Mulch: Mulch shall be maintained until covered with growing grass seedlings. Material that has been removed from the site by wind or other causes shall be replaced and secured.

3.06 COMPLETENESS

- A. The lawn and grass operations shall not be considered complete until a uniform (e.g., evenly distributed, without large bare areas) perennial vegetative cover with a density of 80% of the native background vegetative cover for the area has been established on all unpaved areas and areas not covered by permanent structures.
- B. If a satisfactory stand of grass has not been produced, the Contractor shall renovate and reseed the grass or unsatisfactory portions thereof.
- C. A satisfactory stand is defined as grass or section of grass that has:
 - 1. No bare spots larger than 1 square foot.
 - 2. Not more than 10 percent of total area with bare spots larger than 1 square foot.
 - 3. Not more than 15 percent of total area with bare spots larger than 6 inches square.

3.06 INTERMITTENT CLEANUP

- A. Immediately following the lawn and grass restoration operations, all gutters, sidewalks, driveways, street pavement, yard or other areas shall be cleaned of all debris, excess sod, topsoil or other objectionable matter. All such cleanup operations shall be completed before sodded areas are measured for payment.

END OF SECTION 6100

SECTION 6700**FENCING****PART 1 - GENERAL****1.01 WORK INCLUDED**

- A. This section covers the materials and procedures used in the construction of chain link and wood fencing.

1.02 RELATED WORK

- A. Section 2200 – Site Preparation.
- B. Section 3500 – Sewage Pump Stations.

1.03 SUBMITTALS

- A. Use of materials other than those specifically listed below is prohibited.
- B. Shop drawings: Layout of fences and gates with dimensions, details, and finishes of components, accessories, and post foundations.
- C. Product data: Manufacturer’s catalog cuts indicating material compliance and specified options.

1.04 QUALITY ASSURANCE

- A. Manufacturer: Provide chain link fencing and gates as complete units controlled by a single source including necessary erection accessories, fittings, and fastenings.
- B. Erector Qualifications: Minimum of two years’ experience installing similar fencing.

1.05 COORDINATION

- A. Details of fence material and construction in this specification take precedence over those shown. General arrangement of fence shall be as shown.

1.06 MANUFACTURER

- A. The chain link fence manufacturer must have a minimum of five (5) years experience manufacturing galvanized coated chain link fencing
- B. Chain link fences and gates, including accessories, fittings, and fastenings must be obtained from a single source.

PART 2 - PRODUCTS**2.01 WOOD FENCE**

- A. Slats: 1-inch x 6-inch x 6-foot – Pine or Cedar
- B. Bottom, Middle, and Top Rail: Pressure treated 2-inch x 4-inch x 8-foot – Pine or Cedar.
- C. Facia: 1-inch x 2-inch – Pine or Cedar

- D. Line Post: 4" x 4" Pressure Treated posts - Cedar
- E. Gate Post: 4" Schedule 40 wall thickness galvanized steel.
- F. Cap: 1" x 6" – Cedar

2.02 CHAIN LINK FENCE FABRIC

- A. Galvanized wire: ASTM A392 Standard Specification for Zinc Coated Steel Chain Link Fence Fabric.
- B. Chain link fence shall be made of steel wire helically wound and interwoven in such a manner as to provide a continuous mesh without knots or ties except in the form of knuckling or twisting the ends of the wire to form the desired selvage of the fabric.
- C. Zinc coating: 2.0 ounce per square foot.
- D. Fabric height: 6 feet
- E. Coated wire: 9 gage.
- F. Mesh size: 2 inches.
- G. PVC-coated fabric: 10-mil heavy mil thickness PVC coating, extruded and adhered to zinc coated wire per Class 2a of ASTM F668. Color: black.

2.03 GALVANIZED FRAMEWORK

- A. The following types of steel frame members are allowed:
 - 1. Steel pipe - Type I: ASTM F 1083, standard weight schedule 40; minimum yield strength of 30,000 psi, hot-dipped galvanized with minimum average 1.8 oz/ft² of coated surface area.
 - 2. Steel pipe - Type II: LG 40 Cold formed and welded steel pipe complying with ASTM F 1043, Group IC, with minimum yield strength of 50,000 psi. Protective coating per ASTM F 1043, 0.9 oz/ft² minimum zinc coating. Internal coating Type B, minimum 0.9 oz/ft² zinc.
- B. Frame Size:
 - 1. End and corner post: 3-inch O.D.
 - 2. Line post: 2-1/2-inch O.D.
 - 3. Rail and braces: 1-5/8-inch O.D.
 - 4. Gate posts: 4-inch O.D.
- C. Provide rails with outside sleeve-type expansion couplings which provide rigid attachment and allow for anticipated movement.
- D. Interrupt rails only at posts.
- E. Continuous top and bottom rails are required. Middle rails only at junction between corner/terminal posts and adjacent line posts.

- F. PVC-coated finish: In accordance with ASTM F1043, apply supplemental color coating of 10 to 15 mils in black color to match fabric.

2.04 SWING GATES

- A. Swing gates shall be installed as shown on the Drawings.
- B. Gate Frames: Gates to be fabricated in accordance with ASTM F 900 using galvanized steel members 1.90-inch O.D. weighing 2.28 lb/ft, welded at all corners. Welded joints coated, employing a zinc-rich paint.
- C. Chain link fabric filler shall match that shown in the fence section. Fabric to be attached to frame by means of tension on fabric bands at the external vertical members and attached by means of tie wires to all horizontal and any internal vertical members. These bands and ties to be a maximum of 15-inch centers. The fabric shall be attached to the bands using a fabric or tension bar.
- D. Swing gates shall be 16 foot double gate and furnished complete with pressed steel corner fittings, pivot-type hinges, locking catch for padlock, drop rod, and "hold open" latching device to secure gates. There shall be sufficient clearance above finished grade so that the gate will fully open a minimum of 90 degrees
- E. The gates shall be topped with 3 strands of barbed wire.
- F. PVC-coated finish: All components of swing gate shall be black coated to match PVC-coated fencing as specified herein.

2.05 ACCESSORIES

- A. Chain link fence accessories: Provide items required to complete fence system. Galvanize each ferrous metal item and finish to match framing. All nuts and bolts to be galvanized.
- B. Post caps: Pressed steel. Provide one cap for each post. Caps must be weatherproof to prevent moisture intrusion into post.
- C. Top rail and brace rail ends: Pressed steel per ASTM F626, for connection of rail and brace to terminal posts.
- D. Top rail sleeves: 6-inch pressed steel.
- E. Wire ties: 9 gauge galvanized steel wire for attachment of fabric to line posts. Double wrap 13 gauge for rails and braces. Hog ring ties of 9 gauge for attachment of fabric to tension wire.
- F. Tension (stretcher) bars made of one continuous piece of steel, 3/16-inch x 3/4-inch. Provide one bar per end or gate post and two bars per corner or pull post.
- G. Tension wire: Galvanized coated steel wire, 7 gauge diameter wire with tensile strength of 75,000 psi.
- H. Truss rods and tightener: 3/8-inch diameter.
- I. Tension Band: 1/8-inch x 1-inch.
- J. Brace Band: 1/8-inch x 1-inch.

- K. Barbed wire: Galvanized coated, per ASTM A-121 Type Z - Class 3 with .80oz/sf zinc coated wire, double strand, 12-1/2 gauge, twisted line wire with, 4 point barbs, spaced approximately 5-inches on center.
- L. Barbed wire supporting arms: Pressed steel arms with provisions for attaching 3 rows of barbed wire. Arms shall withstand 250 lb. downward pull at outermost end of arm without failure.
- M. PVC-coated finish: All fencing accessories shall be black coated to match PVC-coated fencing as specified herein.

PART 3 - EXECUTION

3.01 PREPARATION

- A. Verify suitability of areas to accept installation.
- B. Verify location of underground utilities before starting installation.
- C. Installation constitutes Contractor acceptance of conditions and responsibility for performance.

3.02 WOOD FENCE INSTALLATION

- A. Install wood fence in accordance with ASTM F537 and manufacturer's instructions.
- B. All posts shall be sound and free from all decay, splits, multiple cracks, or any other defect which would weaken the posts or otherwise cause them to be structurally unsuitable for the purpose intended.
- C. Locate terminal post at each fence termination and change in horizontal or vertical direction of 30° or more.
- D. The maximum distance between posts in any section shall not exceed eight (8) feet.
- E. The top, middle, and bottom railings shall be securely fastened to the posts with galvanized nails or other acceptable means.
- F. Fence slats shall be placed on the roadway side of posts unless otherwise specified.
- G. The slats shall be sound and free from all major decay or defects which would weaken or otherwise cause them to be unsuitable for fence slats.
- H. The slats shall be placed approximately two (2) inches above the ground, and on a straight grade between posts by excavating high points of the ground.
- I. Concrete set posts: Drill holes in firm, undisturbed or compacted soil. Holes shall have diameter 4 times greater than the outside dimension of the post, and depths approximately 6-inches deeper than post bottom. Excavate deeper as required for adequate support in soft and loose soils, and for posts with heavy lateral loads. Set post bottom 26-inches below surface when in firm, undisturbed soil. Place concrete around posts in a continuous pour. Trowel finish around post. Slope to direct water away from posts.
- J. Set posts in Class A concrete.
- K. Plumb posts to 1/4 inch in 8 feet. Check each post for vertical and top alignment, and maintain in position during placement and finishing operations.

- L. Filling depressions will be permitted only upon approval of the Public Works Director.

3.03 CHAIN LINK FENCE FRAMING INSTALLATION

- A. Install chain link fence in accordance with ASTM F567 and manufacturer's instructions.
- B. Locate terminal post at each fence termination and change in horizontal or vertical direction of 30° or more.
- C. Space line posts uniformly at 10 foot on center maximum.
- D. Concrete set posts: Drill holes in firm, undisturbed or compacted soil. Holes shall have diameter 4 times greater than the outside dimension of the post, and depths approximately 6-inches deeper than post bottom. Excavate deeper as required for adequate support in soft and loose soils, and for posts with heavy lateral loads. Set post bottom 36-inches below surface when in firm, undisturbed soil. Place concrete around posts in a continuous pour. Trowel finish around post. Slope to direct water away from posts.
- E. Set posts in Class A concrete.
- F. Plumb posts to 1/4 inch in 10 feet. Check each post for vertical and top alignment, and maintain in position during placement and finishing operations.
- G. Bracing: Install horizontal pipe brace at mid-height on each side of terminal or corner posts. Firmly attach with fittings. Install diagonal truss rods at these points. Adjust truss rod, ensuring posts remain plumb.
- H. Install bracing assemblies at end and gate posts and at both sides of corner and pull posts.
 - 1. Locate compression members at mid-height of fabric.
 - 2. Extend diagonal tension members from compression members to bases of posts.
 - 3. Install so that posts are plumb when under correct tension.

3.04 CHAIN LINK FABRIC INSTALLATION

- A. Fabric: Install fabric on security side and attach so that fabric remains in tension after pulling force is released. Leave approximately 2 inches between finish grade and bottom selvage. Attach fabric with wire ties to line posts at 15 inches on center and to rails, braces, and tension wire at 24 inches on center. A tension wire shall be installed at the bottom selvage of all fabric.
- B. Tension bars: Pull fabric taught; thread tension bar through fabric and attach to terminal posts with bands or clips spaced maximum of 15inches on center.

3.05 ACCESSORIES

- A. Tie wires: bend ends of wire to minimize hazard to persons and clothing.
- B. Fasteners: Install nuts on side of fence opposite fabric side for added security.

END OF SECTION 6700

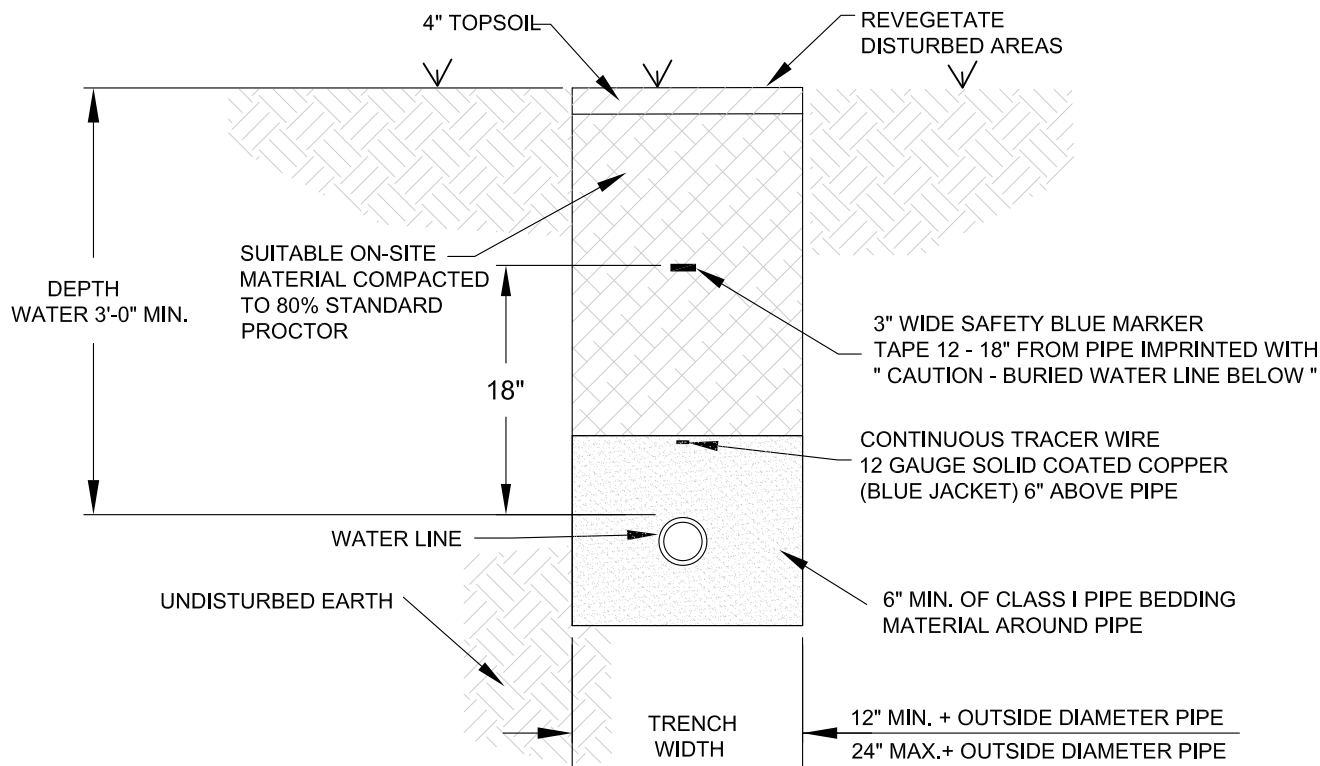

NOTES:

1. ALL VALVES, BENDS, ETC. SHALL BE RESTRAINED.
2. THE CONTRACTOR SHALL PROVIDE ALL ITEMS NECESSARY TO CONNECT WITH ANY PART OF THE EXISTING WATER SYSTEM THAT WILL REMAIN IN ORDER TO ESTABLISH A SATISFACTORY AND ACCEPTABLE WATER SYSTEM.
3. CONTRACTOR TO CONSTRUCT ALL TRENCH EXCAVATION IN ACCORDANCE WITH ALL OSHA REGULATIONS (29 CFR CH.XVII, SUBPART B)
4. TRENCH SHALL BE EXCAVATED BELOW GRADE REQUIRED TO PROVIDE A MINIMUM 36" OF PIPE COVER.
5. MAXIMUM PIPE COVER SHALL BE 60" UNDER NORMAL CONDITIONS. COVER GREATER THAN 60" MAY BE ALLOWED FOR SHORT DISTANCES WHERE REQUIRED BY FIELD CONDITIONS. NO HYDRANT SHALL BE ALLOWED WHERE LINES ARE GREATER THAN 60" DEEP.

WATER MAIN TRENCH

(NON-PAVED AREA)



CITY OF BRYANT, AR
 WATER UTILITIES
 210 S.W. 3rd. STREET
 BRYANT, AR
 PHONE: (501) 943-0468

TITLE: WATER DETAILS	
DESCRIPTION: WATER MAIN TRENCH (NON-PAVED AREA)	
DRAWN BY:	CHECKED BY:
FILE: W1-Water Trench (Non-Paved Area).dwg	

DATE: APRIL 2015
REVISED

SHEET:
W1

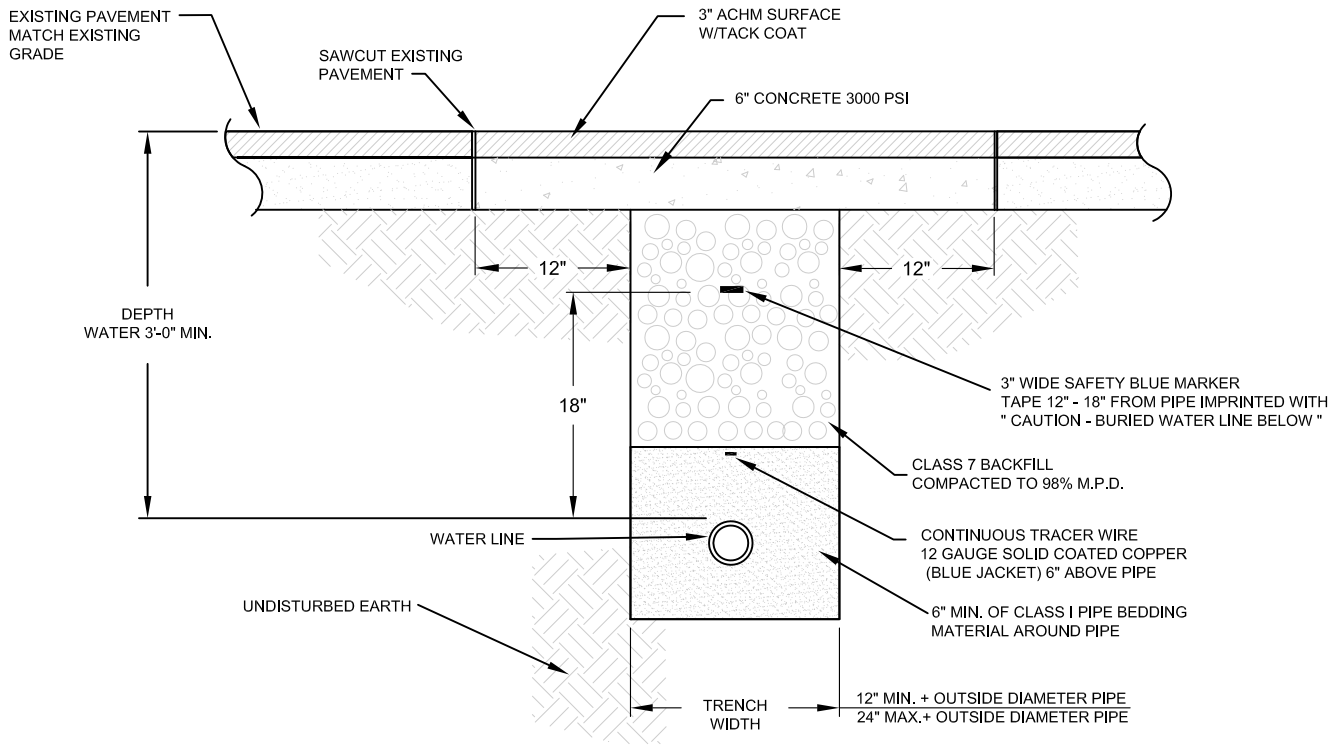

WATER MAIN TRENCH
(UNDER ASPHALT)

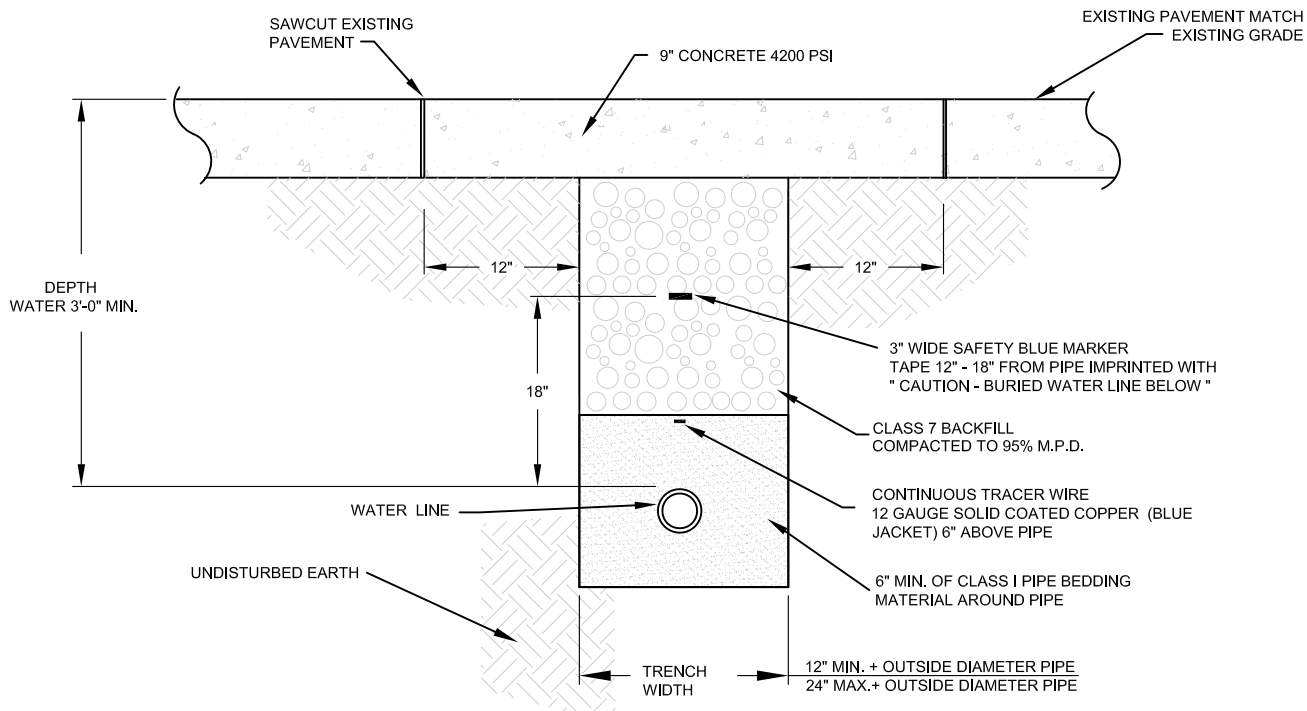

WATER MAIN TRENCH
(UNDER CONCRETE)

NOTES:

1. ALL VALVES, BENDS, ETC. SHALL BE RESTRAINED.
2. THE CONTRACTOR SHALL PROVIDE ALL ITEMS NECESSARY TO CONNECT WITH ANY PART OF THE EXISTING WATER SYSTEM THAT WILL REMAIN IN ORDER TO ESTABLISH A SATISFACTORY AND ACCEPTABLE WATER SYSTEM.
3. CONTRACTOR TO CONSTRUCT ALL TRENCH EXCAVATION IN ACCORDANCE WITH ALL OSHA REGULATIONS (29 CFR CH.XVII, SUBPART B)
4. TRENCH SHALL BE EXCAVATED BELOW GRADE REQUIRED TO PROVIDE A MINIMUM 36" OF PIPE COVER.
5. MAXIMUM PIPE COVER SHALL BE 60" UNDER NORMAL CONDITIONS. COVER GREATER THAN 60" MAY BE ALLOWED FOR SHORT DISTANCES WHERE REQUIRED BY FIELD CONDITIONS. NO HYDRANT SHALL BE ALLOWED WHERE LINES ARE GREATER THAN 60" DEEP.



CITY OF BRYANT, AR
WATER UTILITIES
210 S.W. 3rd. STREET
BRYANT, AR
PHONE: (501) 943-0468

TITLE: WATER DETAILS		DATE: APRIL 2015	SHEET: W2
DESCRIPTION: WATER MAIN TRENCH (UNDER PAVEMENT)		REVISED	
DRAWN BY:	CHECKED BY:	----	
FILE: W2-Water Trench (Under Pavement).dwg		----	

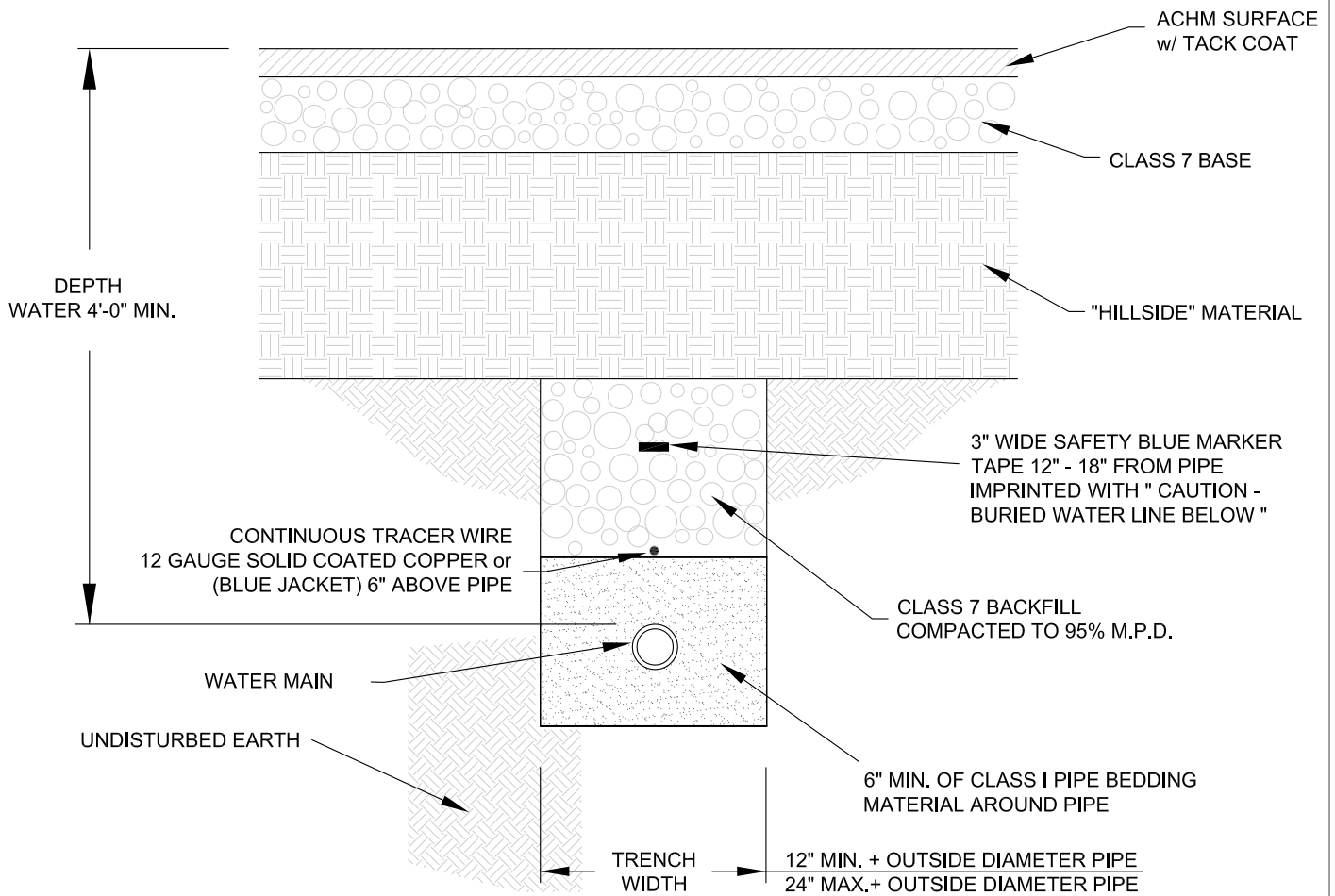

WATER MAIN INSTALLATION PRIOR TO ROADWAY CONSTRUCTION

NOTES:

1. ALL VALVES, BENDS, ETC. SHALL BE RESTRAINED.
2. THE CONTRACTOR SHALL PROVIDE ALL ITEMS NECESSARY TO CONNECT WITH ANY PART OF THE EXISTING WATER SYSTEM THAT WILL REMAIN IN ORDER TO ESTABLISH A SATISFACTORY AND ACCEPTABLE WATER SYSTEM.
3. CONTRACTOR TO CONSTRUCT ALL TRENCH EXCAVATION IN ACCORDANCE WITH ALL OSHA REGULATIONS (29 CFR CH.XVII, SUBPART B)
4. TRENCH SHALL BE EXCAVATED BELOW GRADE REQUIRED TO PROVIDE A MINIMUM 36" OF PIPE COVER.
5. MAXIMUM PIPE COVER SHALL BE 60" UNDER NORMAL CONDITIONS. COVER GREATER THAN 60" MAY BE ALLOWED FOR SHORT DISTANCES WHERE REQUIRED BY FIELD CONDITIONS. NO HYDRANT SHALL BE ALLOWED WHERE LINES ARE GREATER THAN 60" DEEP.



CITY OF BRYANT, AR
 WATER UTILITIES
 210 S.W. 3rd. STREET
 BRYANT, AR
 PHONE: (501) 943-0468

TITLE:	WATER DETAILS	
DESCRIPTION:	WATER MAIN INSTALLATION PRIOR TO ROADWAY CONSTRUCTION	
DRAWN BY:	CHECKED BY:	FILE: W3-Water Main Installation Prior to Roadway Const.dwg

DATE:	APRIL 2015
REVISED:	----

SHEET:
W3

PERMITTED VALVES

1. AMERICAN FLOW CONTROL SERIES 2500
2. MUELLER SERIES 2360
3. AMERICAN AVK COMPANY SERIES 25 OR SERIES 45

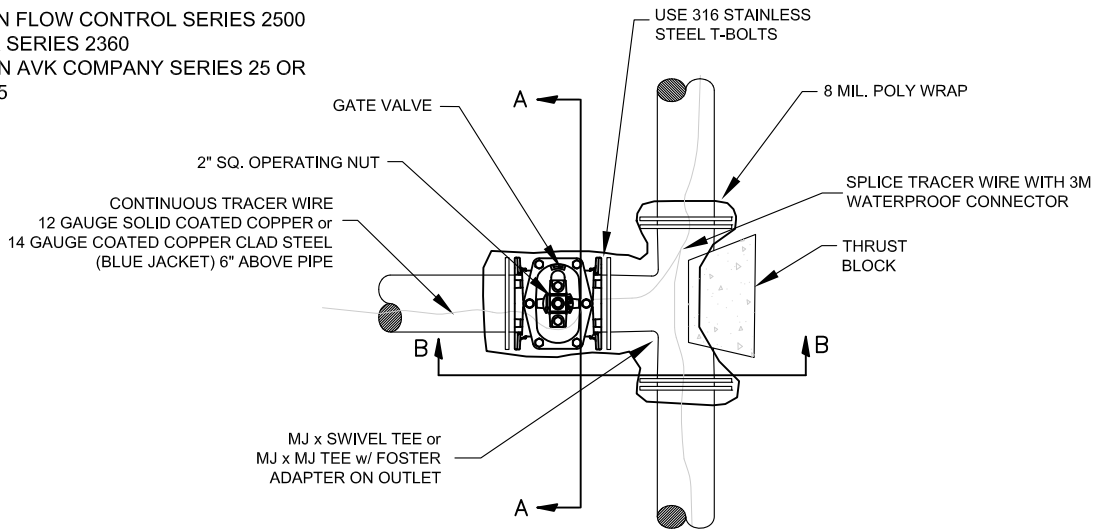

PLAN

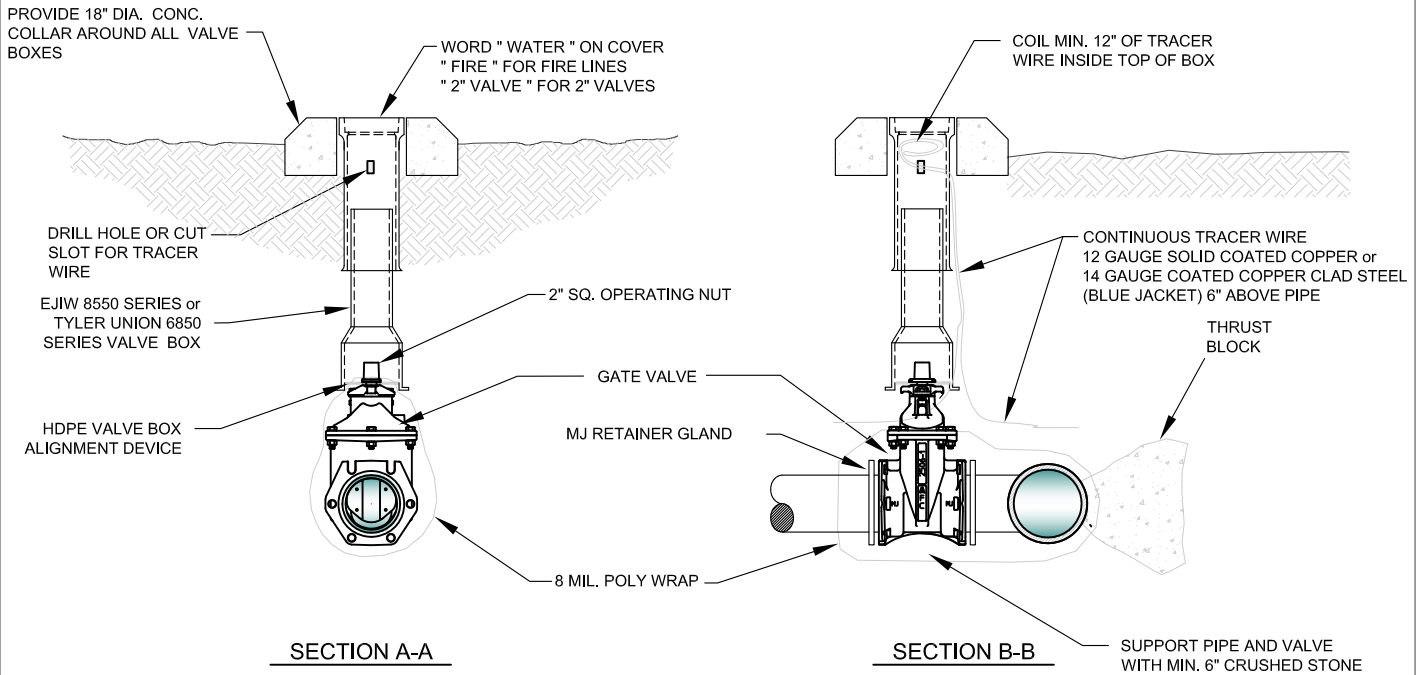

NOTES:

1. ALL VALVES SHALL BE SECURELY ANCHORED TO THE TEE.
2. ALL HARDWARE SHALL BE 316 STAINLESS STEEL.
3. IF DEPTH OF BURY EXCEEDS 4 FT., A VALVE STEM EXTENSION SHALL BE REQUIRED. THE VALVE STEM EXTENSION NUT SHALL BE WITHIN 24-INCHES TO 12-INCHES OF THE FINISHED SURFACE.

GATE VALVE DETAIL

2" - 12"



CITY OF BRYANT, AR
 WATER UTILITIES
 210 S.W. 3rd. STREET
 BRYANT, AR
 PHONE: (501) 943-0468

TITLE:	WATER DETAILS	
DESCRIPTION:	GATE VALVE	
DRAWN BY:	CHECKED BY:	FILE: W4-Gate Valve.dwg

DATE:	APRIL 2015
	REVISED

SHEET:
W4

PERMITTED VALVES

1. AMERICAN FLOW CONTROL SERIES 2500
2. MUELLER SERIES 2360
3. AMERICAN AVK COMPANY SERIES 25 OR SERIES 45

NOTES:

1. ALL VALVES SHALL BE SECURELY ANCHORED TO THE TEE.
2. ALL HARDWARE SHALL BE 316 STAINLESS STEEL.
3. IF DEPTH OF BURY EXCEEDS 4 FT., A VALVE STEM EXTENSION SHALL BE REQUIRED. THE VALVE STEM EXTENSION NUT SHALL BE WITHIN 24-INCHES TO 12-INCHES OF THE FINISHED SURFACE.

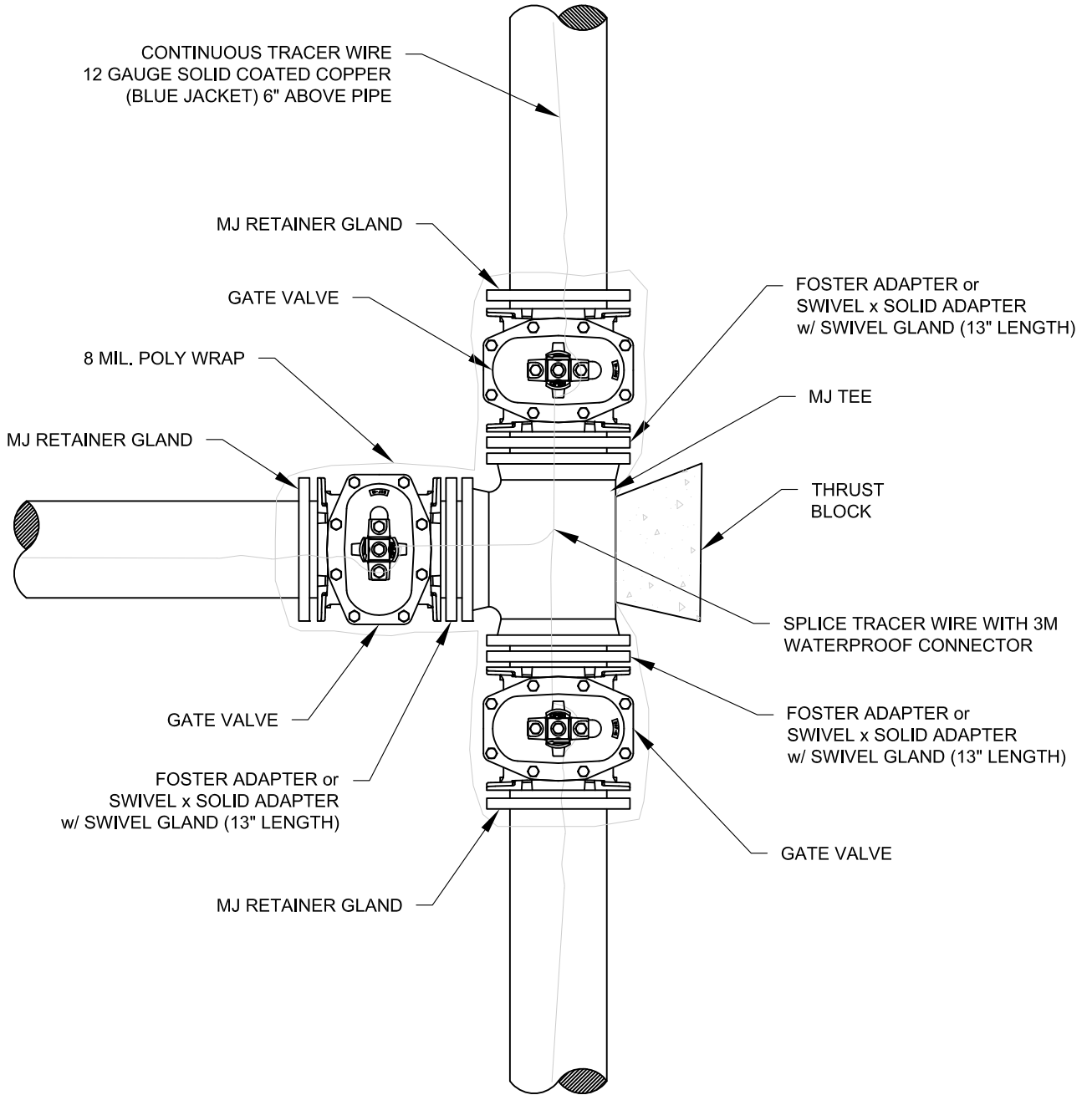

3-WAY GATE VALVE DETAIL



CITY OF BRYANT, AR
 WATER UTILITIES
 210 S.W. 3rd. STREET
 BRYANT, AR
 PHONE: (501) 943-0468

TITLE:	WATER DETAILS	
DESCRIPTION:	3-WAY GATE VALVES	
DRAWN BY:	CHECKED BY:	FILE: W5-3-Way Gate Valves.dwg

DATE:	APRIL 2015
REVISION:	----
REVISION:	----
REVISION:	----
REVISION:	----
REVISION:	----

SHEET:
W5

NOTES:

1. ALL HARDWARE SHALL BE 316 STAINLESS STEEL.
2. IF DEPTH OF BURY EXCEEDS 4 FT., A VALVE STEM EXTENSION SHALL BE REQUIRED. THE VALVE STEM EXTENSION NUT SHALL BE WITHIN 24-INCHES TO 12-INCHES OF THE FINISHED SURFACE.
3. ALL VALVES SHALL BE DOUBLE WRAPPED WITH 8 MIL POLY.

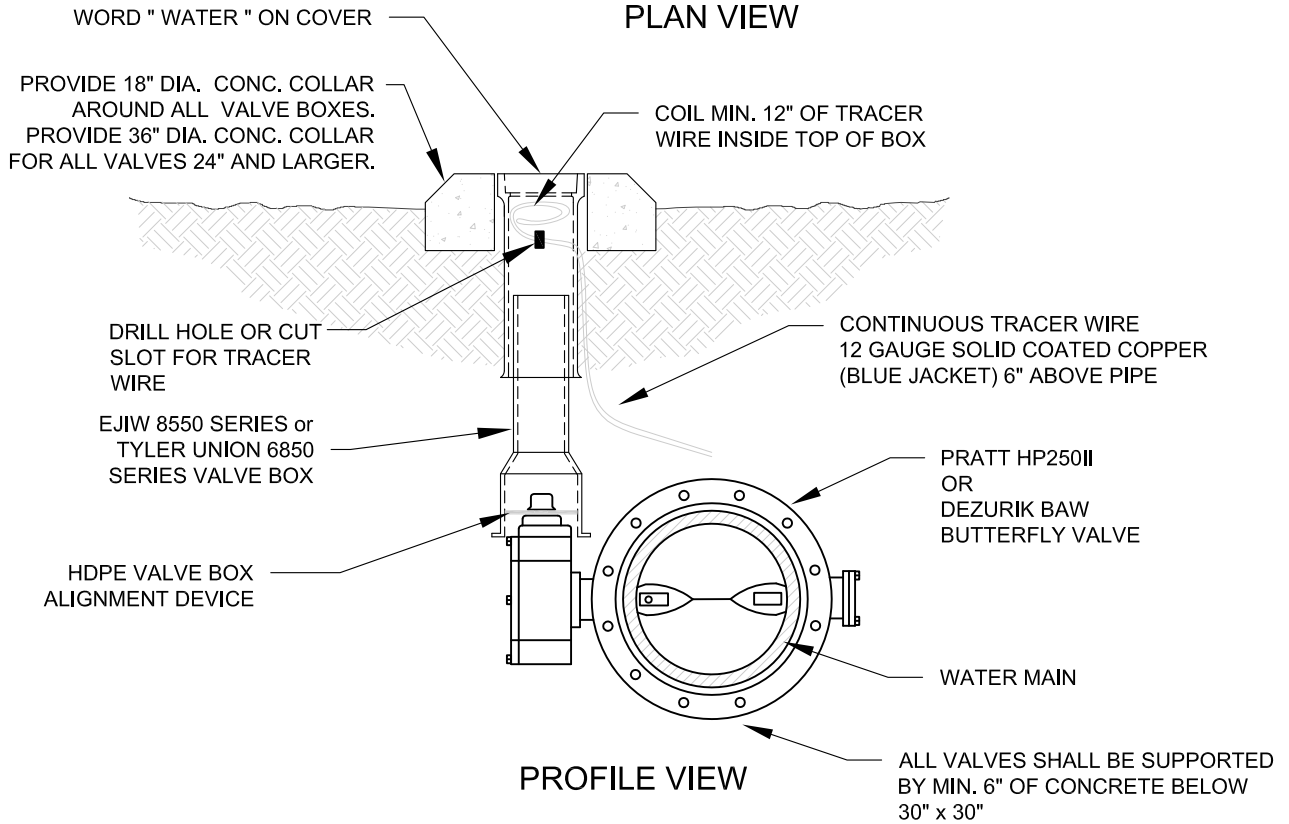
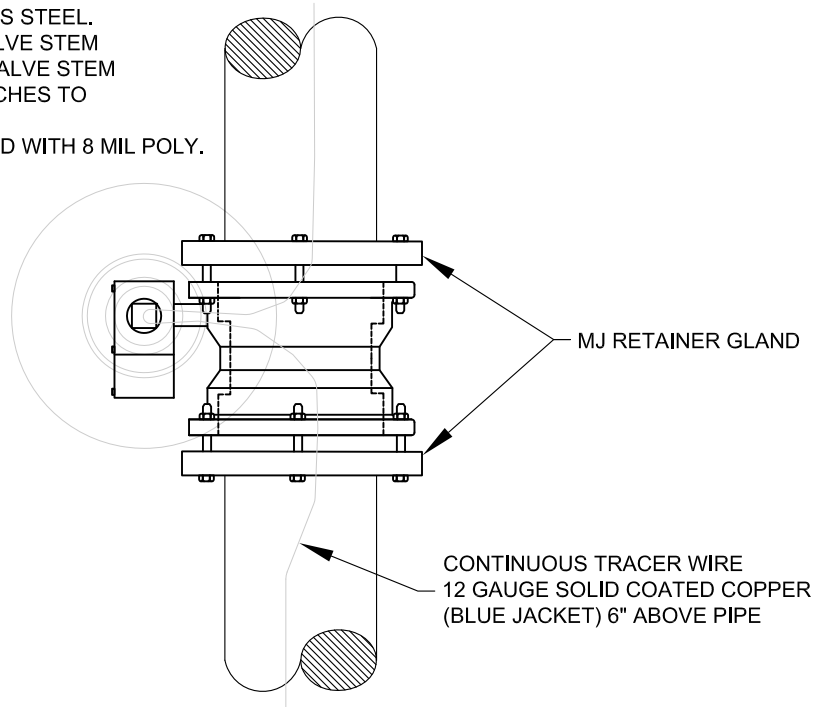

BUTTERFLY VALVE DETAIL
14-INCH WATER MAINS AND LARGER



CITY OF BRYANT, AR
WATER UTILITIES
210 S.W. 3rd. STREET
BRYANT, AR
PHONE: (501) 943-0468

TITLE:	WATER DETAILS	
DESCRIPTION:	BUTTERFLY VALVE	
DRAWN BY:	CHECKED BY:	FILE: W6-Butterfly Valve.dwg

DATE:	APRIL 2015
	REVISED

SHEET:
W6

NOTES:

1. OPERATING NUT EXTENSIONS SHALL BE USED WHEN THE TOP OF THE OPERATING NUT IS GREATER THAN 4 FEET FROM THE TOP OF FINISHED SURFACE.
2. THE STEM EXTENSION SHALL BE OF ADEQUATE LENGTH TO REACH FROM THE VALVE OPERATING NUT TO A POINT WITHIN 24-INCHES TO 12-INCHES OF THE FINISHED SURFACE.

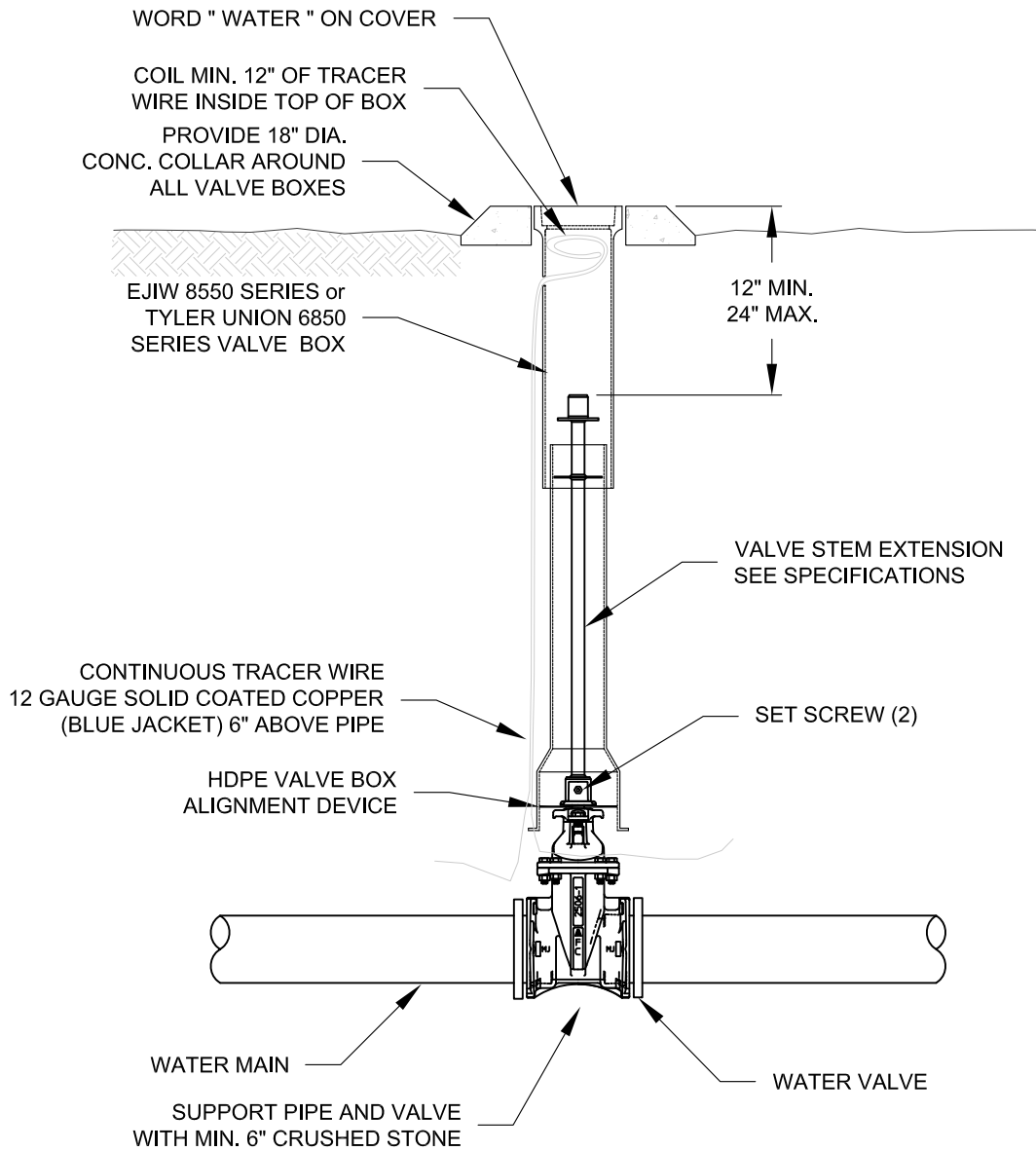

VALVE WITH STEM EXTENSION



CITY OF BRYANT, AR
 WATER UTILITIES
 210 S.W. 3rd. STREET
 BRYANT, AR
 PHONE: (501) 943-0468

TITLE:	WATER DETAILS	
DESCRIPTION:	VALVE STEM EXTENSION	
DRAWN BY:	CHECKED BY:	FILE: W7-Valve Stem Extension.dwg

DATE:	APRIL 2015
REVISION:	----
REVISION:	----
REVISION:	----
REVISION:	----
REVISION:	----

SHEET:
W7

NOTES:

1. THE 6" GATE VALVE SHALL BE POSITIVELY RESTRAINED TO THE MAIN BY THE USE OF EITHER A SWIVEL TEE OR FOSTER ADAPTER.
2. FIRE HYDRANTS SHALL BE DESIGNED FOR A MINIMUM 48" BURY.
3. BURY LINE OF HYDRANT SHALL BE NO LESS THAN THE PROPOSED FINISHED ELEVATION OF BACK OF CURB, OR SIDEWALK, WHICHEVER IS GREATER.
4. EXTENSIONS SHALL BE WATEROUS K562 OR MUELLER A-320 WITH NO MORE THAN ONE EXTENSION PER HYDRANT.
5. IF SIDEWALK IS PRESENT, HYDRANT SHALL BE INSTALLED 2' MINIMUM BEHIND THE BACK OF THE SIDEWALK OR CURB. VALVES SHALL BE INSTALLED 1' MINIMUM BEHIND THE BACK OF THE SIDEWALK OR CURB.
6. DO NOT COVER UP WEEP HOLE WITH CONCRETE.
7. MJ RETAINER GLANDS ARE REQUIRED FOR ALL FITTINGS.
7. 6" DUCTILE IRON PIPE IS REQUIRED FOR ALL FIRE HYDRANT LEADS GREATER THAN 48-INCHES FROM THE MAIN VALVE.
8. AN ADDITIONAL GUARDIAN VALVE IS REQUIRED FOR ALL FIRE HYDRANT LEADS GREATER THAN 30 FEET IN LENGTH.

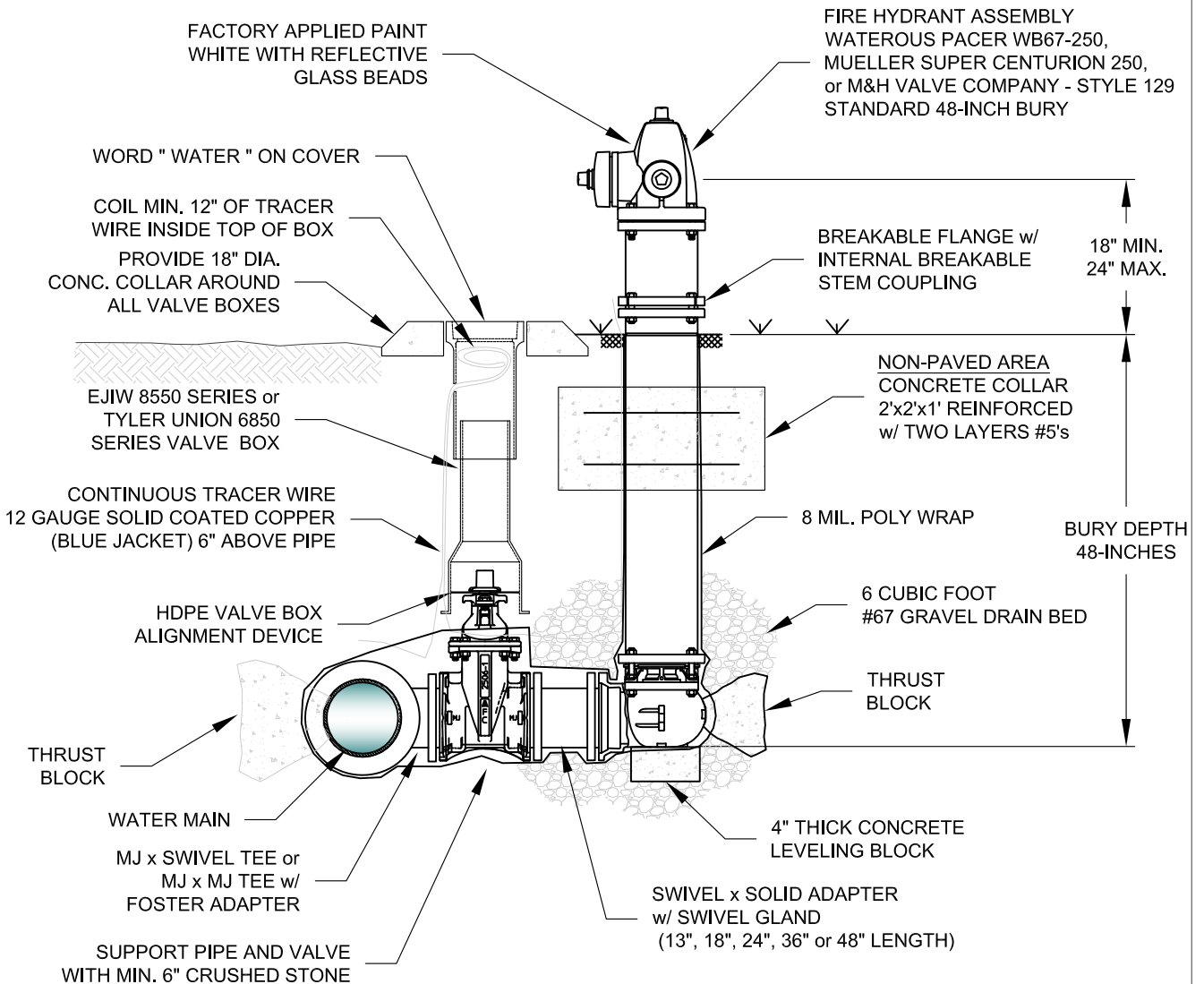

FIRE HYDRANT & VALVE CONNECTION



CITY OF BRYANT, AR
 WATER UTILITIES
 210 S.W. 3rd. STREET
 BRYANT, AR
 PHONE: (501) 943-0468

TITLE:	WATER DETAILS	
DESCRIPTION:	FIRE HYDRANT AND VALVE CONNECTION	
DRAWN BY:	CHECKED BY:	FILE: W8-Fire Hydrant and Valve.dwg

DATE:	APRIL 2015
	REVISED

SHEET:
W8

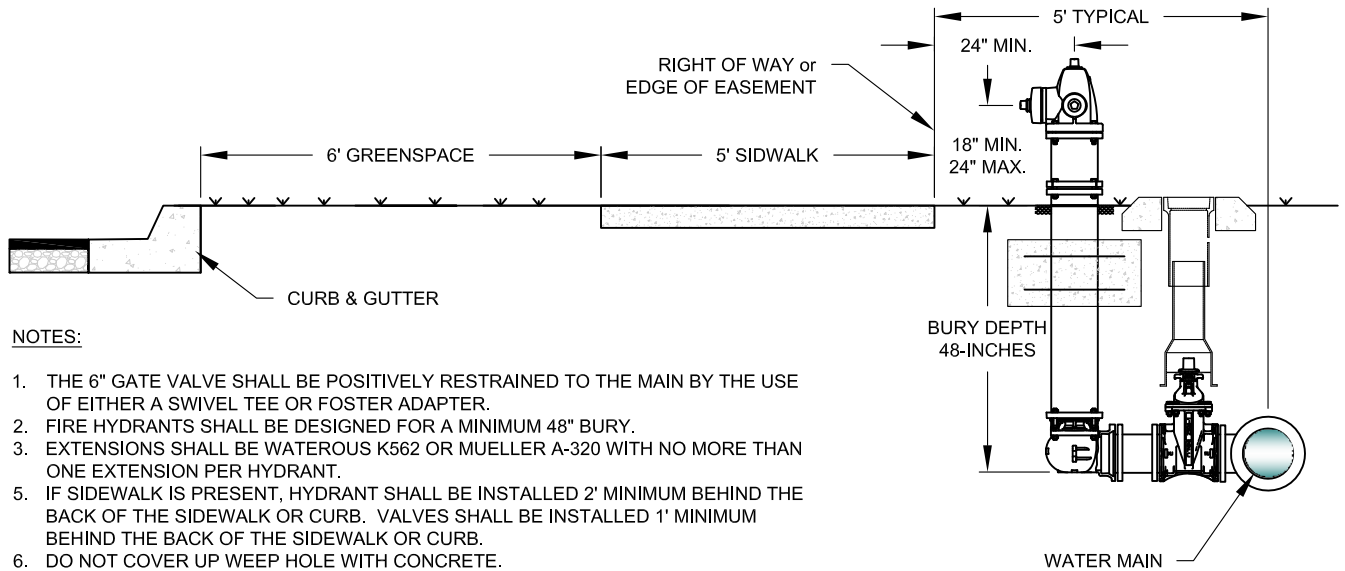

NOTES:

1. THE 6" GATE VALVE SHALL BE POSITIVELY RESTRAINED TO THE MAIN BY THE USE OF EITHER A SWIVEL TEE OR FOSTER ADAPTER.
2. FIRE HYDRANTS SHALL BE DESIGNED FOR A MINIMUM 48" BURY.
3. EXTENSIONS SHALL BE WATEROUS K562 OR MUELLER A-320 WITH NO MORE THAN ONE EXTENSION PER HYDRANT.
5. IF SIDEWALK IS PRESENT, HYDRANT SHALL BE INSTALLED 2' MINIMUM BEHIND THE BACK OF THE SIDEWALK OR CURB. VALVES SHALL BE INSTALLED 1' MINIMUM BEHIND THE BACK OF THE SIDEWALK OR CURB.
6. DO NOT COVER UP WEEP HOLE WITH CONCRETE.
7. MJ RETAINER GLANDS ARE REQUIRED FOR ALL FITTINGS.
7. 6" DUCTILE IRON PIPE IS REQUIRED FOR ALL FIRE HYDRANT LEADS GREATER THAN 48-INCHES FROM THE MAIN VALVE.
8. AN ADDITIONAL GUARDIAN VALVE IS REQUIRED FOR ALL FIRE HYDRANT LEADS GREATER THAN 30 FEET IN LENGTH.

BURY DEPTH
48-INCHES

WATER MAIN

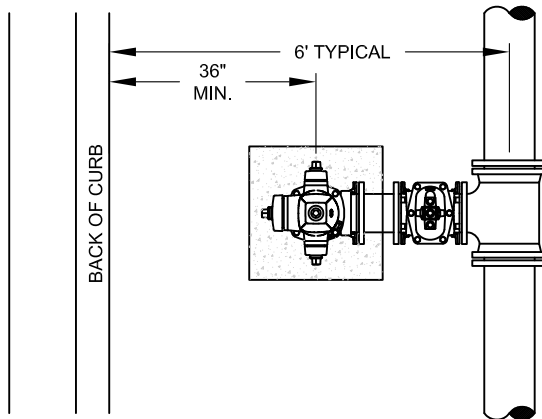

WATER LINE BEHIND CURB
INSIDE ROW

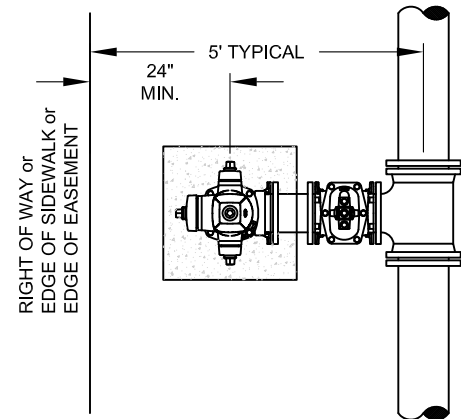

WATER LINE IN EASEMENT
OUTSIDE ROW

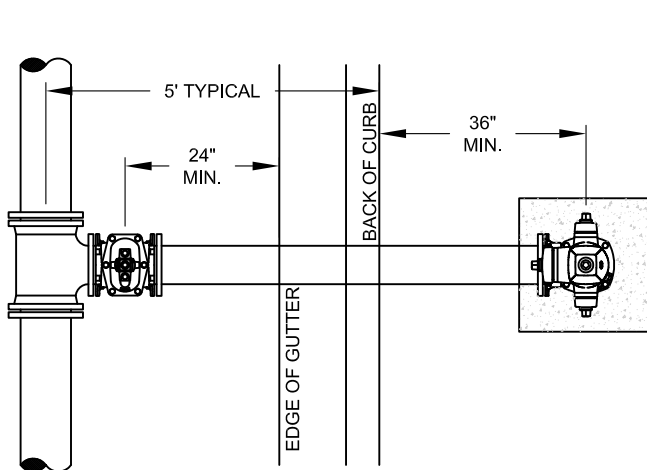

WATER LINE IN STREET
INSIDE ROW

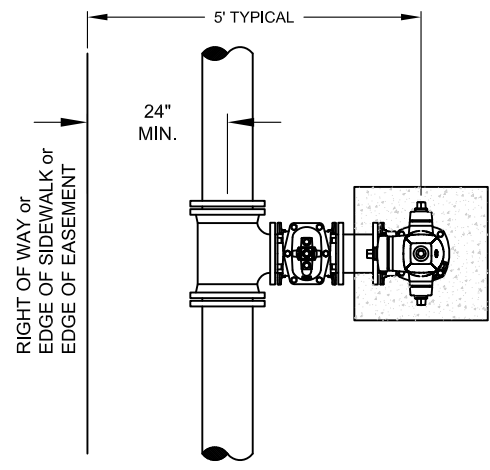

WATER LINE IN EASEMENT
OUTSIDE ROW



CITY OF BRYANT, AR
WATER UTILITIES
210 S.W. 3rd. STREET
BRYANT, AR
PHONE: (501) 943-0468

TITLE: WATER DETAILS		
DESCRIPTION: FIRE HYDRANT PLACEMENT		
DRAWN BY:	CHECKED BY:	FILE: W9-Fire Hydrant Placement.dwg

DATE: APRIL 2015	SHEET:
REVISED	

W9

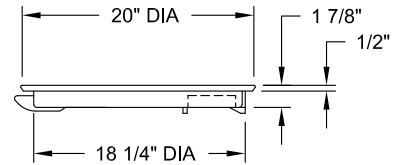
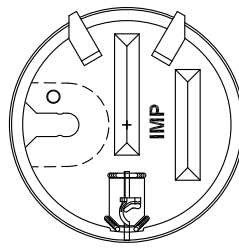
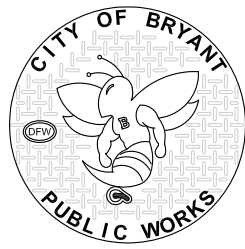

BOTTOM VIEW
WATER METER LID

COVER SECTION

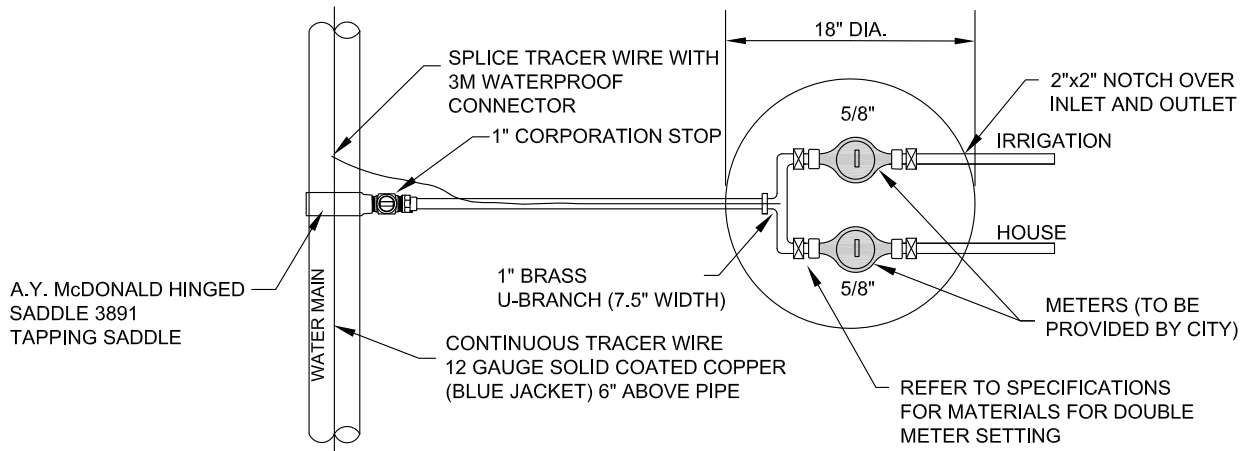

DOUBLE METER SETTING
ONLY FOR 1 LOT

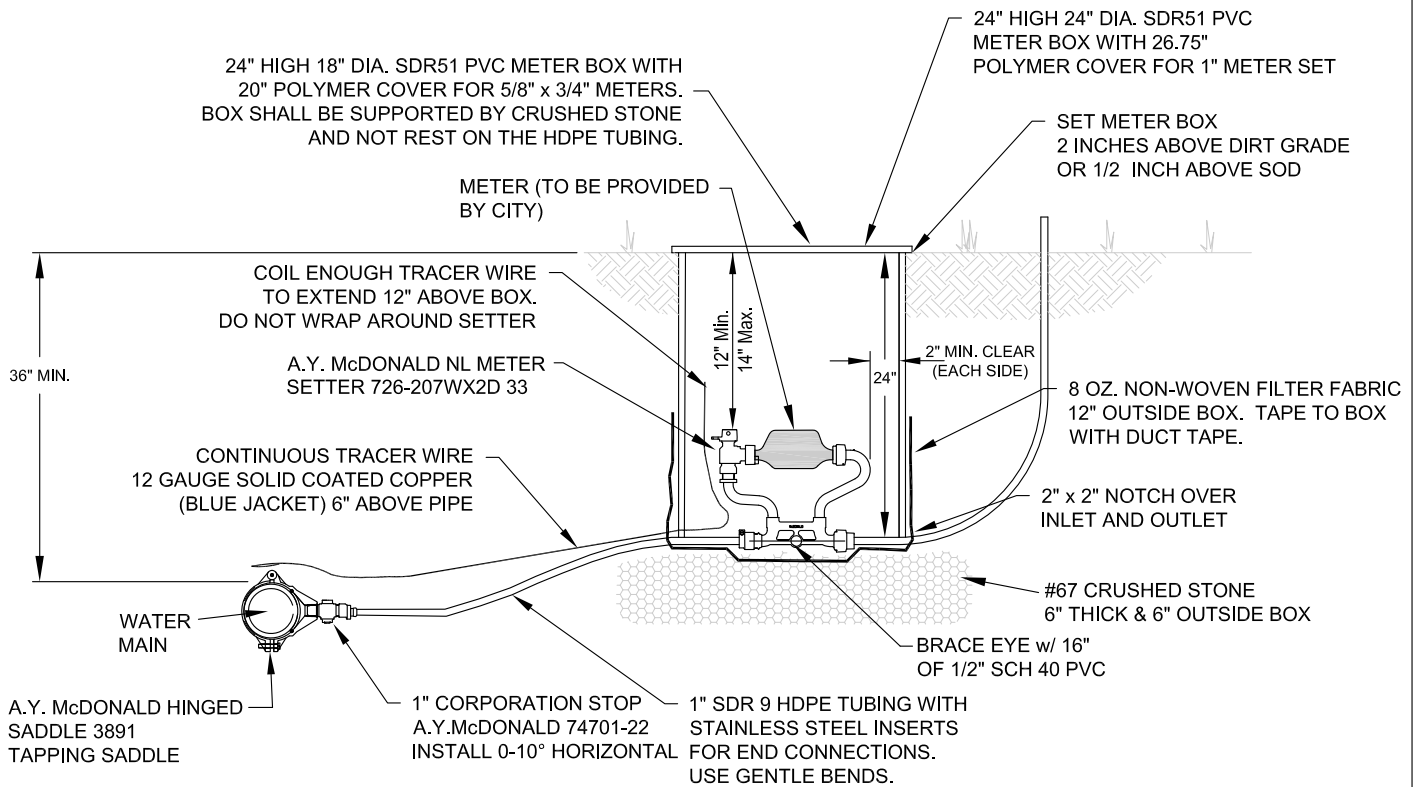

SINGLE METER SETTING



CITY OF BRYANT, AR
WATER UTILITIES
210 S.W. 3rd. STREET
BRYANT, AR
PHONE: (501) 943-0468

TITLE:	WATER DETAILS	
DESCRIPTION:	METER SETTINGS	
DRAWN BY:	CHECKED BY:	FILE: W10-Meter Settings.dwg

DATE:	APRIL 2015	SHEET:
	REVISED	

W10

NOTES:

1. ALL WATER & SANITARY SEWER TRENCHES WHICH ARE UNDER THE PROPOSED STREETS MUST BE BACKFILLED AS SHOWN ON THE TRENCHING, BEDDING, AND BACKFILL STANDARD DETAIL.
2. WATER AND SEWER LINES SHALL MAINTAIN A MINIMUM OF HORIZONTAL SEPARATION DISTANCE OF 10 FEET AT ALL TIMES.
3. WATER AND SEWER LINES SHALL MAINTAIN A MINIMUM VERTICAL SEPARATION OF 18 INCHES WITH THE WATER LINE CROSSING ABOVE THE SEWER LINE.
4. ALL CORP. STOPS SHALL BE INSTALLED AT 0-10° ANGLE FROM HORIZONTAL.
5. A MINIMUM OF 24-INCHES OF SEPARATION IS REQUIRED BETWEEN SERVICE TAPS.
6. ALL METER BOXES SHALL BE INSTALLED ON THE CUSTOMER SIDE OF THE WATER MAIN.
7. ALL METER BOXES SHALL BE INSTALLED IN NON-PAVED AREAS. ANY METER BOX THAT GETS PLACED IN A PAVED AREA SHALL BE RELOCATED AT THE OWNER'S EXPENSE BEFORE A WATER METER WILL BE INSTALLED.

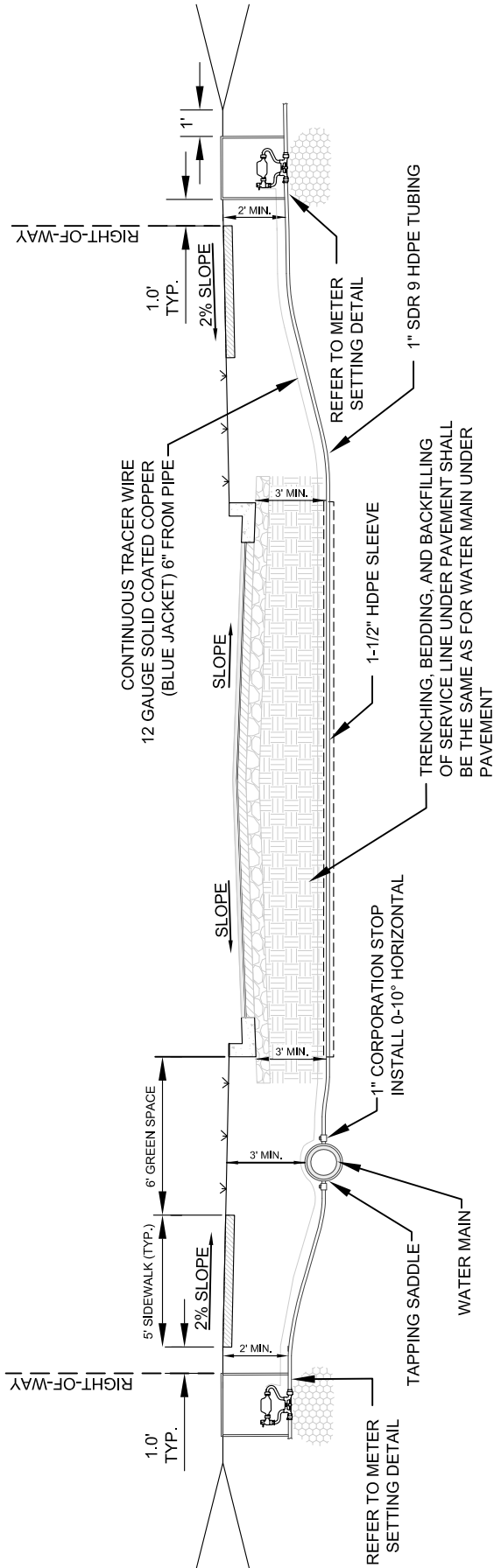

SERVICE METER WITH WATER MAIN UNDER PAVEMENT



CITY OF BRYANT, AR
 WATER UTILITIES
 210 S.W. 3rd. STREET
 BRYANT, AR
 PHONE: (501) 943-0488

TITLE: WATER DETAILS	
DESCRIPTION: METER SERVICE LINE UNDER PAVEMENT	
DRAWN BY:	CHECKED BY:
FILE: W11-Meter Service Line Under Pavement.dwg	

DATE: APRIL 2015
REVISED

SHEET: **W11**

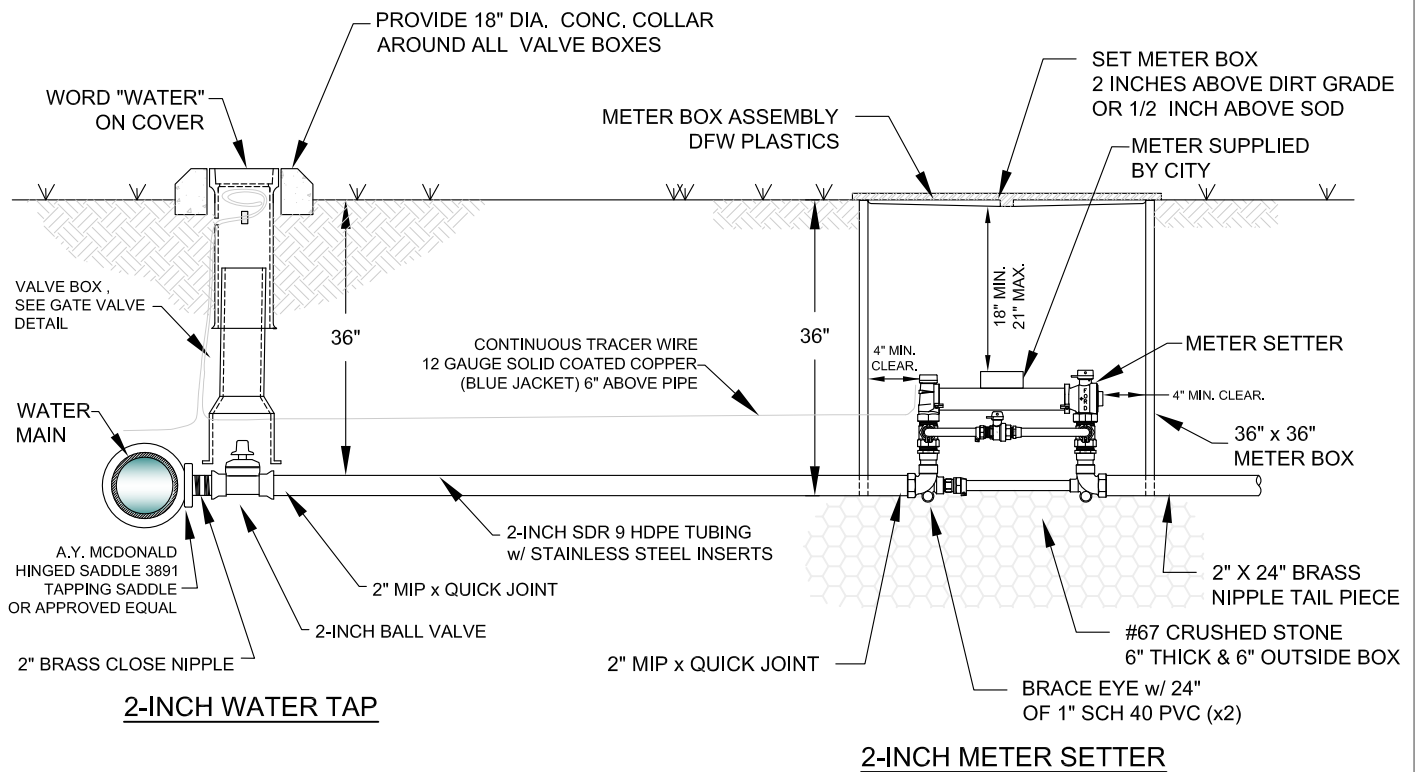

NOTES:

1. COORDINATE INSTALLATION AND CONFIGURATION OF ALL 1-1/2" AND LARGER METER SETTINGS WITH THE CITY.
2. ALL METER BOXES SHALL BE INSTALLED IN NON-PAVED AREAS. ANY METER BOX THAT GETS PLACED IN A PAVED AREA SHALL BE RELOCATED AT THE OWNER'S EXPENSE BEFORE A WATER METER WILL BE INSTALLED.
3. SUPPORT METER INSTALLATION WITH 1"x24" SCH40 PVC THROUGH EACH BRACE EYE.

2" WATER SERVICE AND WATER METER



CITY OF BRYANT, AR
 WATER UTILITIES
 210 S.W. 3rd. STREET
 BRYANT, AR
 PHONE: (501) 943-0468

TITLE:	WATER DETAILS	
DESCRIPTION:	1-1/2" AND 2" WATER WATER METER	
DRAWN BY:	CHECKED BY:	FILE: W12-2 inch Water Meter.dwg

DATE:	APRIL 2015
	REVISED

SHEET:
W12

NOTES:

1. TAPPING SLEEVE SHALL BE SMITH-BLAIR 662 OR FORD FAST.
2. AFTER THE TAP IS MADE, RE-TORQUE BOLTS ON SLEEVE TO SEAL TO FINAL SHAPE OF PIPE.
3. TAPPING SLEEVE AND VALVE SHALL BE WRAPPED WITH 8 MIL POLY WRAP.

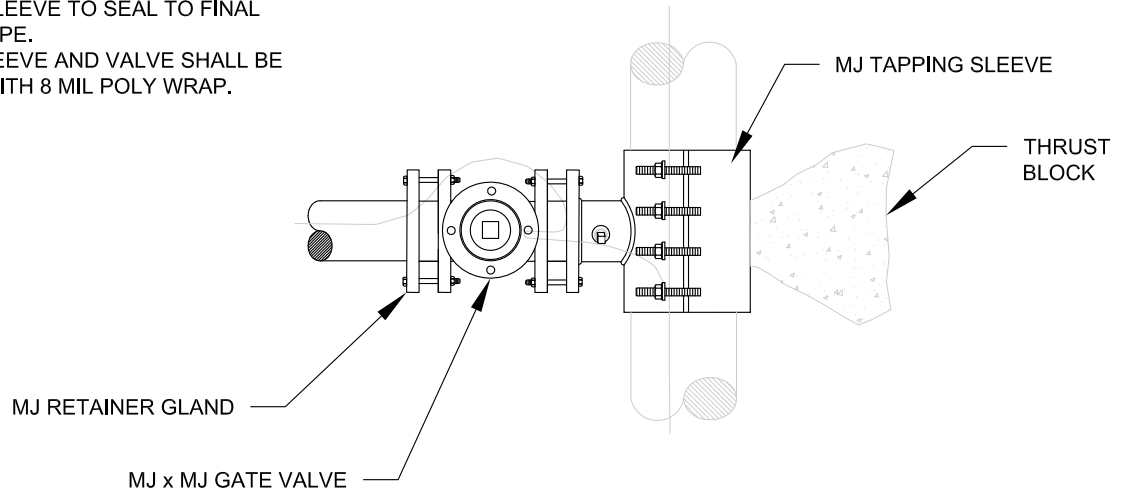

PLAN VIEW

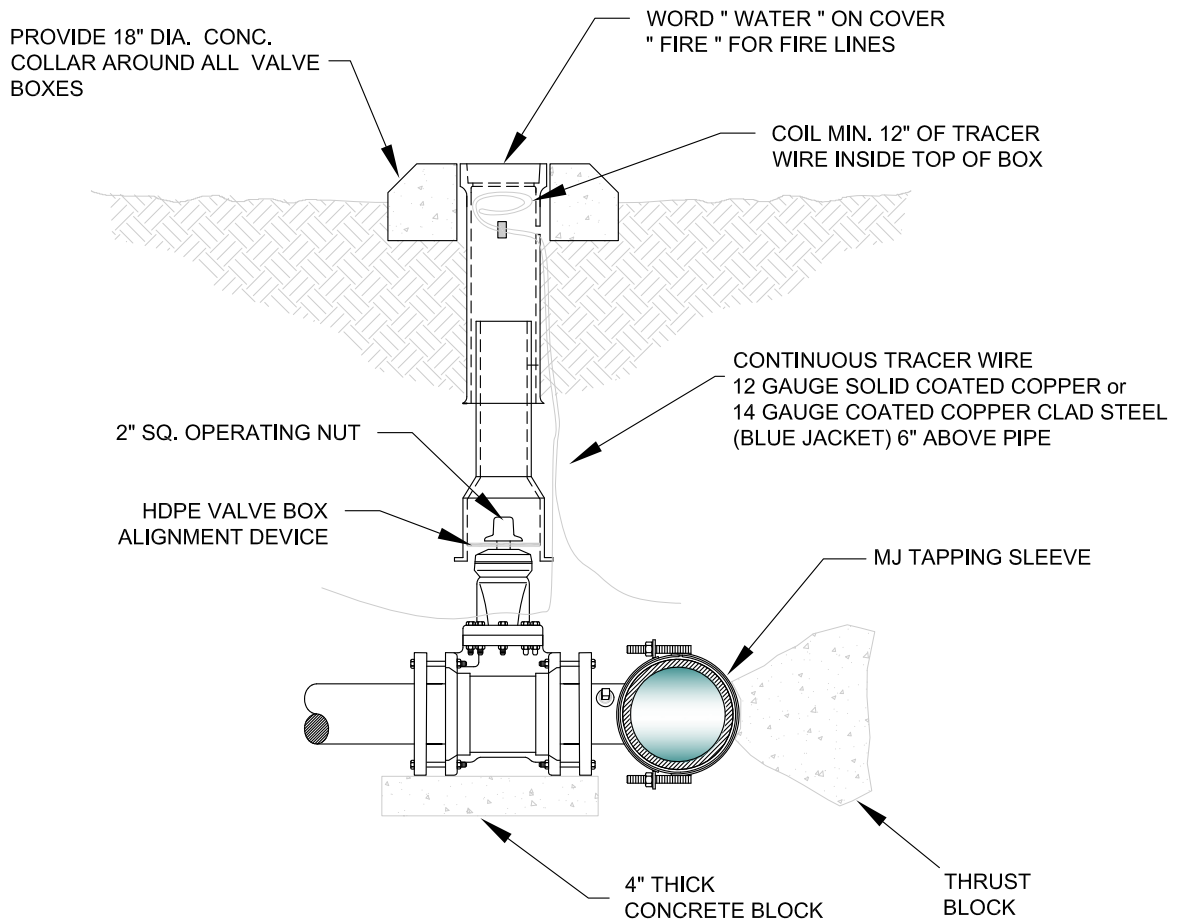

PROFILE VIEW



CITY OF BRYANT, AR
 WATER UTILITIES
 210 S.W. 3rd. STREET
 BRYANT, AR
 PHONE: (501) 943-0468

TITLE:	WATER DETAILS	
DESCRIPTION:	TAPPING SLEEVE AND VALVE	
DRAWN BY:	CHECKED BY:	FILE: W13-Tapping Sleeve and Valve.dwg

DATE:	APRIL 2015
	REVISED

SHEET:
W13

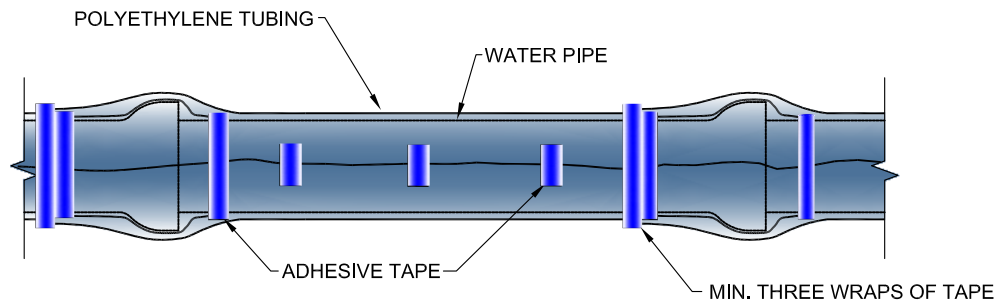

METHOD 'A'

METHOD 'A' USES ONE LENGTH OF POLYETHYLENE TUBE, OVERLAPPED AT THE JOINTS A MINIMUM OF 2 FEET.

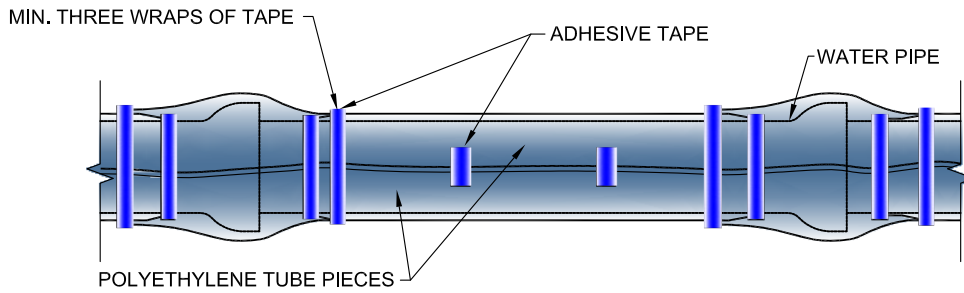

METHOD 'B'

METHOD 'B' USES SEPARATE PIECES OF POLYETHYLENE TUBE FOR THE BARREL OF THE PIPE AND THE JOINTS. SHORT PIECES SHALL BE APPROXIMATELY 6' LONG AND OVERLAP BARREL SECTION BY A MINIMUM OF 2 FEET.

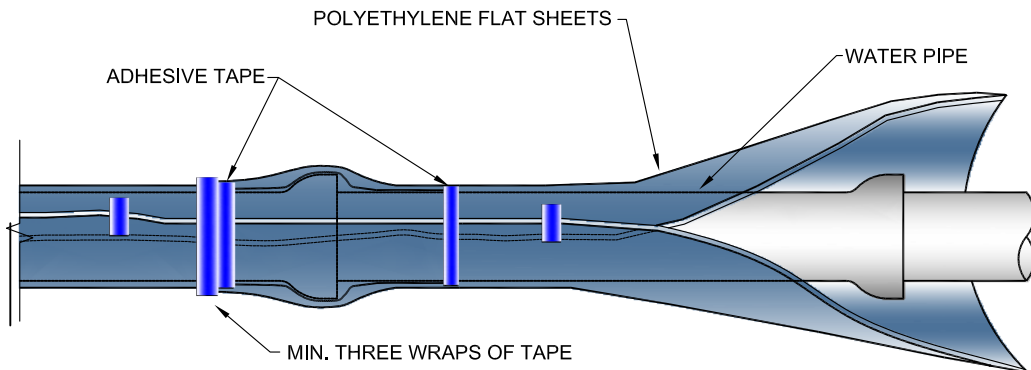

METHOD 'C'

METHOD 'C' - USED FOR PIPE-SHAPED AND ODD-SHAPED APPURTENANCES SUCH AS BENDS, REDUCERS, OFFSETS, VALVES, TEES, ETC.

ALL DUCTILE IRON PIPE AND FITTINGS SHALL BE POLY WRAPPED.

THE ANSI/AWWA C105/A21.5 STANDARD OUTLINES THREE METHODS OF INSTALLING POLYETHYLENE ENCASEMENT/ SLEEVING.



CITY OF BRYANT, AR
 WATER UTILITIES
 210 S.W. 3rd. STREET
 BRYANT, AR
 PHONE: (501) 943-0468

TITLE:	WATER DETAILS	
DESCRIPTION:	POLYETHYLENE PROTECTION MATERIAL	
DRAWN BY:	CHECKED BY:	FILE: W14-Poly Wrap.dwg

DATE:	APRIL 2015
REVISED:	----

SHEET:
W14

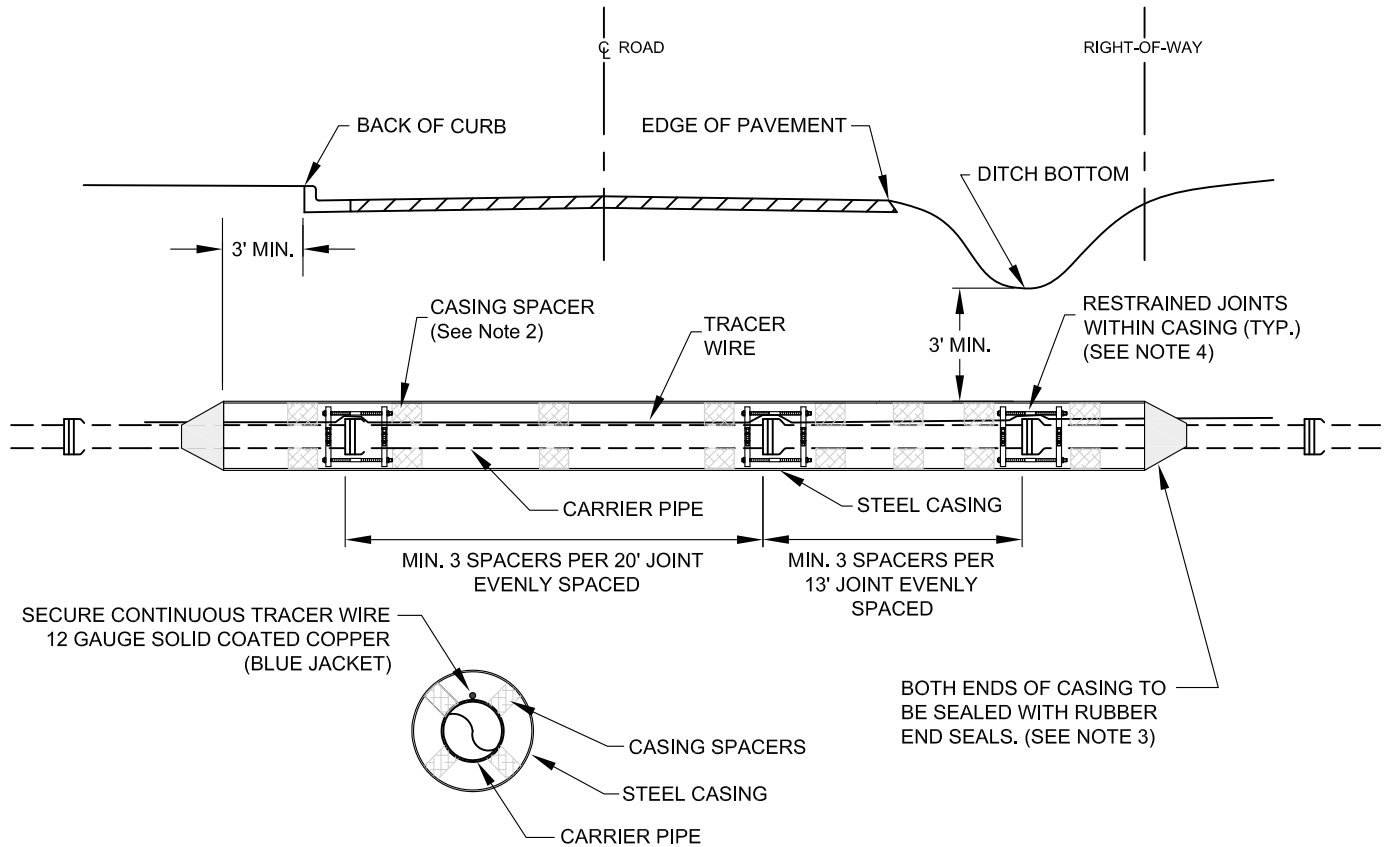

NOTES:

1. STEEL CASING SHALL BE CONSTRUCTED OF SPIRAL OR STRAIGHT WELDED STEEL WITH A MINIMUM DIAMETER AND THICKNESS AS SHOWN BELOW (SEE TABLE).
2. PROVIDE CASING SPACERS BY CASCADE MODEL CCS AS MANUFACTURED BY CASCADE WATERWORKS MFG. CO., OR APPROVED EQUAL.
3. PROVIDE END SEALS BY CASCADE MODEL CCEs AS MANUFACTURED BY CASCADE WATERWORKS MFG. CO., OR APPROVED EQUAL.
4. WHERE ENCASEMENTS ARE GREATER THAN 25 FEET IN LENGTH, SELF-RESTRAINING GASKETS OR BELL RESTRAINTS SHALL BE USED FOR ALL JOINTS INSIDE THE ENCASEMENT PIPE AND FOR THE FIRST JOINT IN EACH DIRECTION OUTSIDE THE ENCASEMENT PIPE.
5. BELL RESTRAINTS FOR PVC SHALL BE SERIES 1900 RESTRAINT HARNESS AND BELL RESTRAINTS FOR DIP SHALL BE SERIES 1700 RESTRAINT HARNESS BY EBAA IRON INC., OR APPROVED EQUAL.
6. DIRECT BURY STEEL ENCASEMENT SHALL BE POLY WRAPPED.
7. JACK AND BORE STEEL ENCASEMENT SHALL HAVE 17# HP MAGNESIUM ANODES CAD WELDED TO THE END OF THE ENCASEMENT PIPE.

CARRIER AND CASING SIZES							
CARRIER (ID)	2"	3"	4"	6"	8"	10"	12"
CASING (ID)	5"	6"	8"	12"	16"	20"	24"
CASING WALL THICKNESS	0.250	0.250	0.250	0.250	0.250	0.250	0.375
CARRIER (ID)	14" - 16"	18" - 20"	24"	30"	36"	42"	48"
CASING (ID)	30"	36"	42"	48"	54"	60"	72"
CASING WALL THICKNESS	0.375	0.500	0.625	0.625	0.625	0.625	0.750

STEEL ENCASEMENT



CITY OF BRYANT, AR
 WATER UTILITIES
 210 S.W. 3rd. STREET
 BRYANT, AR
 PHONE: (501) 943-0468

TITLE:	WATER DETAILS	
DESCRIPTION:	STEEL ENCASEMENT	
DRAWN BY:	CHECKED BY:	FILE: W15-Steel Encasement.dwg

DATE:	APRIL 2015
	REVISED

SHEET:
W15

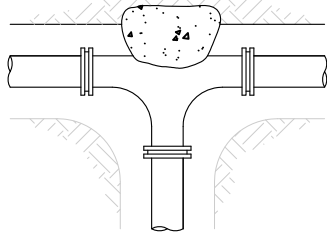

TEE

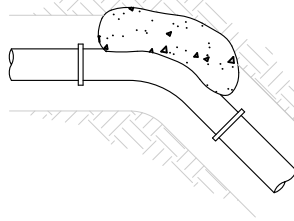

11 1/4°, 22 1/2°
AND/OR 45° BEND

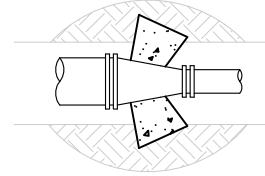

REDUCER

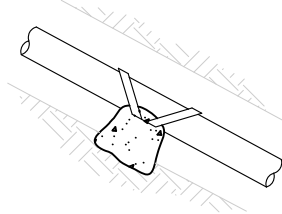

HORIZONTAL RUN

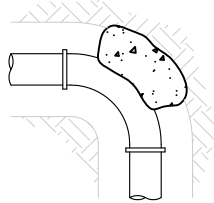

90° BEND *

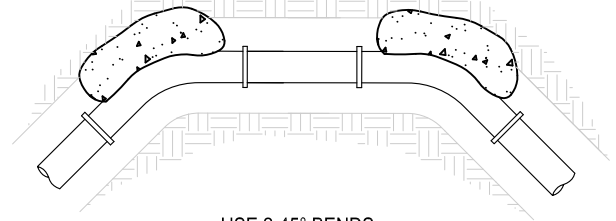

USE 2-45° BENDS
IN PLACE OF 90° BEND

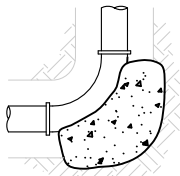

VERTICAL RUN
SEE SHEET W18 FOR
VERTICAL TIE-DOWN BLOCKING

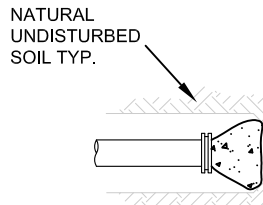

END PLUG, CAP
OR BLIND FLANGE

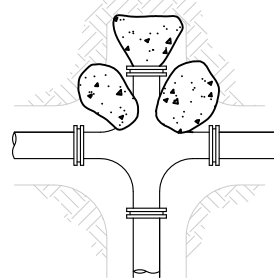

CROSS WITH PLUG

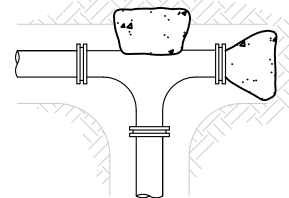

TEE WITH PLUG

THRUST BLOCK SCHEDULE												
(2000 PSF SOIL, 200 PSI WATER PRESSURE, 100 PSI WATER HAMMER)												
BEARING AREA OF THRUST BLOCKS IN SQ. FT. (HORIZONTAL BENDS)						VOLUME OF THRUST BLOCK IN CU. FEET (VERTICAL BENDS)						
FITTING SIZE	PLUG TEE OR CAP	BEND ANGLE				FITTING SIZE	BEND ANGLE				ROD DIAM.	EMBEDMENT
		90° *	45°	22 1/2°	11 1/4°		90° *	45°	22 1/2°	11 1/4°		
2, 3, & 4	1.9	2.7	1.4	0.7	0.4	2, 3, & 4	35.5	19.2	9.8	4.9	.50"	30"
6	5.6	7.9	4.3	2.2	1.1	6	105.8	57.2	29.2	14.7	.75"	30"
8	9.6	13.6	7.4	3.8	1.9	8	181.9	98.5	50.2	25.2	.75"	30"
12	20.5	29.0	15.7	8.0	4.0	12	387.1	209.5	106.8	53.7	1.0"	30"
16	35.7	50.4	27.3	13.9	7.0	16	672.6	364.0	185.6	93.2	1.0"	36"
18	44.8	63.4	34.3	17.5	18.8	18	844.7	457.2	233.1	117.1	1.0"	36"
24	78.4	110.9	60.0	30.6	15.4	24	1478.7	800.3	408.0	205.0	1.5"	36"

* 90 DEGREE BENDS SHALL ONLY BE USED ON A BY-EXCEPTION BASIS, AND MUST EACH BE SPECIFICALLY APPROVED BY CITY.

THRUST BLOCK NOTES:

1. CONCRETE FOR THRUST BLOCKS - CLASS A CONCRETE SHALL DEVELOP NOT LESS THAN 3000 P.S.I. COMPRESSIVE STRENGTH AT 28 DAYS AND BE PLACED AGAINST UNDISTURBED SOIL.
2. ALL BENDS, BOTH HORIZONTAL AND VERTICAL, SHALL BE BACKED WITH CONCRETE. VERTICAL BENDS SHALL BE PLACED ON CONCRETE PADS WHERE BENDS TURN UP, OR LOADED WHERE BENDS TURN DOWN.
3. WRAP PIPE JOINTS IN 8 MIL "POLYETHYLENE" BEFORE PLACING CONCRETE.
4. BEARING AREA SHOWN IN TABLE, IS BASED UPON A 2000 LB/SF. SOIL BEARING, AND UPON A PIPELINE PRESSURE OF 200 psi. PLUS 100 psi. WATER HAMMER. AREAS SHOWN SHALL BE ADJUSTED, SHOULD FIELD CONDITIONS VARY.
5. MJ RESTRAINTS ARE REQUIRED FOR ALL FITTINGS.
6. USE LONG-RADIUS FITTINGS WHEREVER POSSIBLE.
7. ALL BOLTS FOR FITTINGS SHALL BE 316 STAINLESS STEEL.
8. ALL DUCTILE IRON FITTINGS SHALL BE FUSION-BONDED EPOXY COATED INSIDE AND OUTSIDE IN ACCORDANCE WITH ANSII/AWWA C116/A21.16.
9. UNIT WEIGHT OF CONCRETE FOR VERTICAL THRUST BLOCKS IS 150 LBS/CU. FT.

THRUST BLOCKING



CITY OF BRYANT, AR
WATER UTILITIES
210 S.W. 3rd. STREET
BRYANT, AR
PHONE: (501) 943-0468

TITLE:	WATER DETAILS		
DESCRIPTION:	THRUST BLOCKING		
DRAWN BY:	CHECKED BY:	FILE: W16-Thrust Blocking.dwg	

DATE:	APRIL 2015
	REVISED

SHEET:
W16

BLOCKING SCHEDULE					
PIPE SIZE	BENDS				ROD DIA.
		45°	22 1/2°	11 1/4°	
8"	VOLUME REQ'D (CU. FT.)	98.5	50.2	25.2	3/4 IN.
	A (FT.)	5.00'	4.00'	3.00'	
	B (FT.)	4.00'	3.20'	2.80'	
	C (FT.)	5.00'	4.00'	3.00'	
	MIN. CLAMP (2 EA.)	3/8 IN. x 2 IN.			
12"	VOLUME REQ'D (CU. FT.)	209.5	106.8	53.7	3/4 IN.
	A (FT.)	6.00'	5.00'	4.00'	
	B (FT.)	6.00'	4.25'	3.50'	
	C (FT.)	6.00'	5.00'	4.00'	
	MIN. CLAMP (2 EA.)	1/2 IN. x 2 IN.			
18"	VOLUME REQ'D (CU. FT.)	457.2	233.1	117.1	1 IN.
	A (FT.)	8.00'	6.50'	5.00'	
	B (FT.)	7.25'	5.50'	4.75'	
	C (FT.)	8.00'	6.50'	5.00'	
	MIN. CLAMP (2 EA.)	5/8 IN. x 3 IN.			
24"	VOLUME REQ'D (CU. FT.)	800.3	408.0	205.0	1 1/4 IN.
	A (FT.)	9.50'	7.50'	6.00'	
	B (FT.)	9.00'	7.25'	5.75'	
	C (FT.)	9.50'	7.50'	6.00'	
	MIN. CLAMP (2 EA.)	5/8 IN. x 3 IN.			

VOLUME CALCULATED ON THE BASIS OF CONCRETE REACTING THRUST ON THE RESPECTIVE BENDS UNDER AN INTERNAL PRESSURE OF 250 PSI, 50 PSI SURGE AND THE WEIGHT OF CONCRETE IS 150 POUNDS PER CU. FT.

ALL FITTINGS SHALL BE MECHANICAL JOINTS WITH RETAINING GLANDS. BEDDING NOT SHOWN

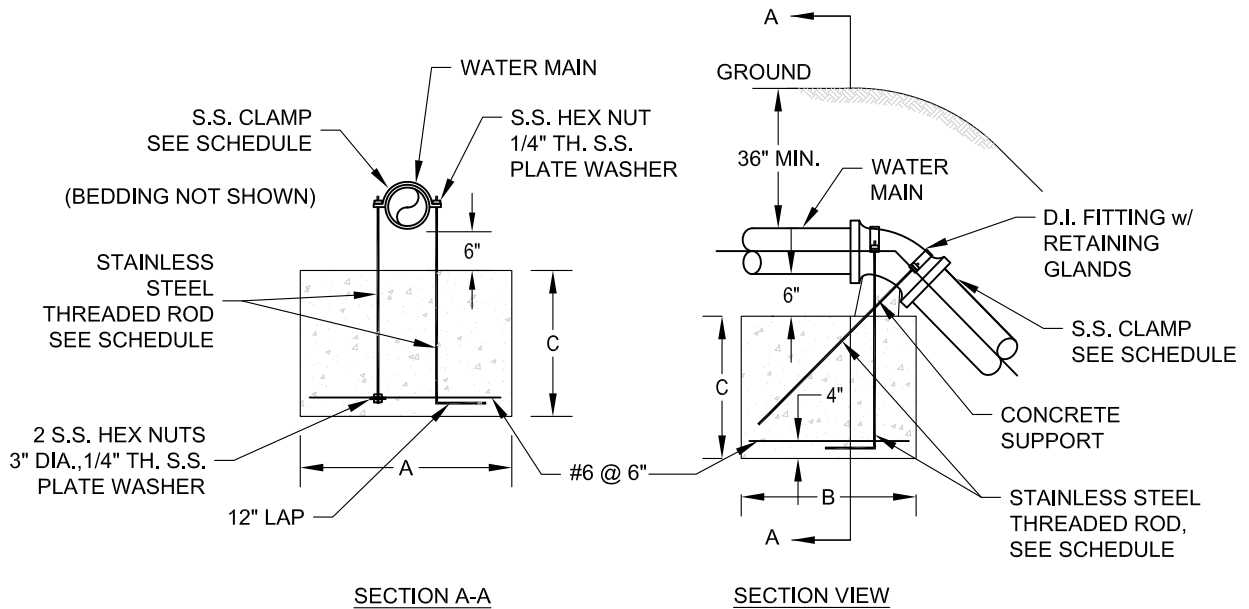

VERTICAL TIE-DOWN BLOCKING



CITY OF BRYANT, AR
 WATER UTILITIES
 210 S.W. 3rd. STREET
 BRYANT, AR
 PHONE: (501) 943-0468

TITLE:	WATER DETAILS	
DESCRIPTION:	VERTICAL TIE-DOWN BLOCKING	
DRAWN BY:	CHECKED BY:	FILE: W17-Vertical Tie-Down Blocking.dwg

DATE:	APRIL 2015
	REVISED

SHEET:
W17

ANCHOR COLLAR SCHEDULE					
PIPE SIZE	* MINIMUM DIMENSIONS *			REINFORCING BARS	
	W	H	T	"A" BARS	"B" BARS
6"	1.5'	2.0'	1.0'	#6 @ 6"	#6 @ 6"
8"	2.0'	2.5'	1.0'	#6 @ 6"	#6 @ 6"
12"	2.5'	4.0'	1.5'	#6 @ 6"	#6 @ 6"
16"	3.5'	5.0'	1.5'	#6 @ 6"	#6 @ 6"
20"	5.0'	5.5'	2.0'	#6 @ 6"	#6 @ 6"
24"	6.5'	6.0'	2.0'	#7 @ 6"	#7 @ 10"

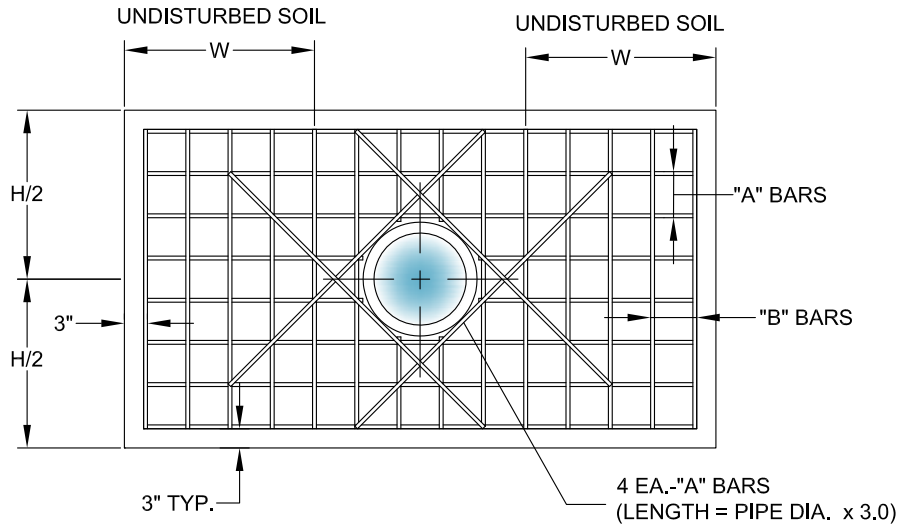

NOTES:

1. DESIGN PRESSURE IS 200 PSI PLUS 100 PSI SURGE AND 2,000 PSI SOIL BEARING.
2. ALL DIMENSIONS ARE MINIMUM REQUIREMENTS. ACTUAL FIELD CONDITIONS MAY REQUIRE LARGER DIMENSIONS.
3. ALL RETAINER GLANDS SHALL BE MEGA-LUG BY EBAA IRON.

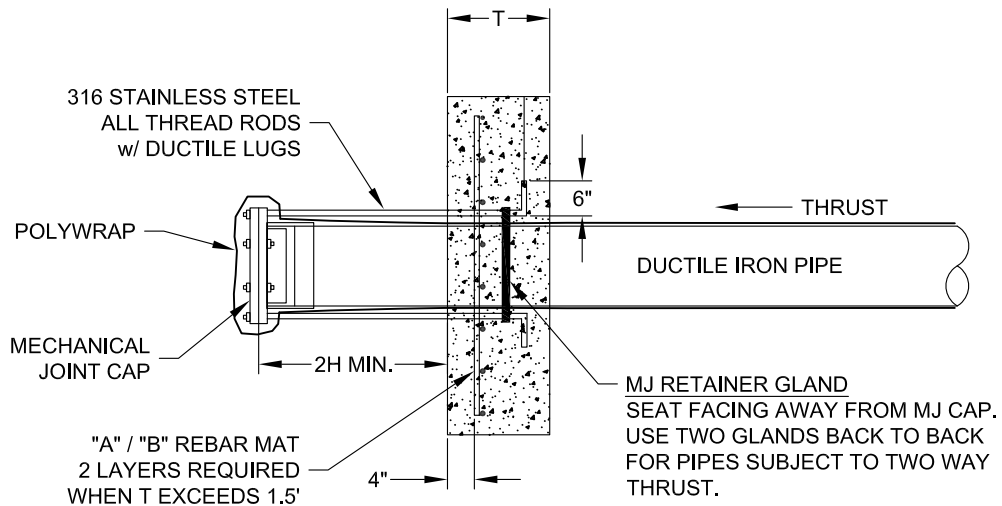

CITY OF BRYANT, AR
 WATER UTILITIES
 210 S.W. 3rd. STREET
 BRYANT, AR
 PHONE: (501) 943-0468

TITLE:	WATER DETAILS	
DESCRIPTION:	ANCHOR COLLAR	
DRAWN BY:	CHECKED BY:	FILE: W18-Anchor Collar.dwg

DATE:	APRIL 2015
REVISED:	----

SHEET:
W18

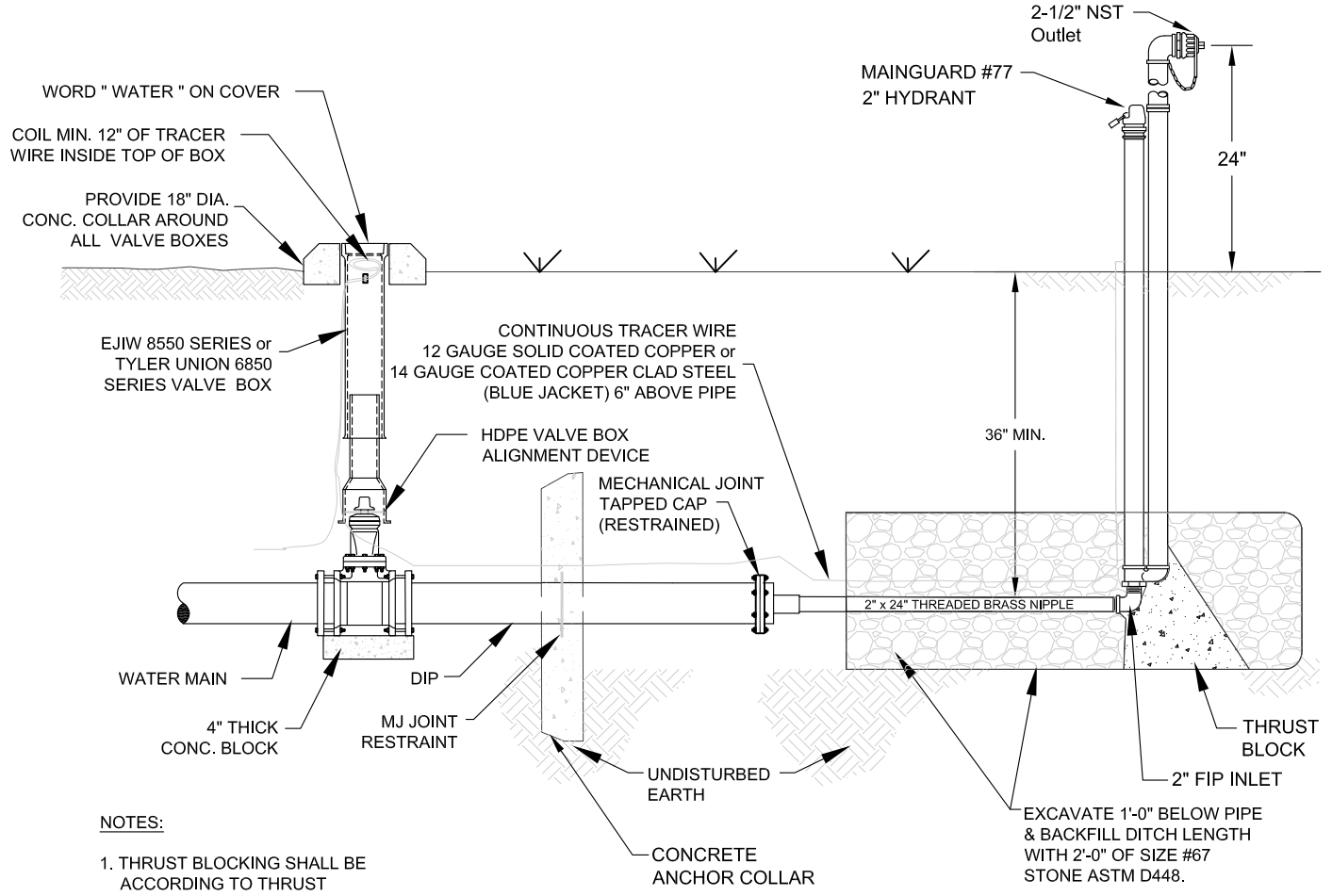

NOTES:

1. THRUST BLOCKING SHALL BE ACCORDING TO THRUST BLOCKING DETAILS.
2. DO NOT COVER UP WEEP HOLE WITH CONCRETE.

BLOW-OFF ASSEMBLY

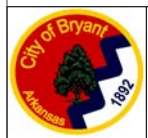

CITY OF BRYANT, AR
 WATER UTILITIES
 210 S.W. 3rd. STREET
 BRYANT, AR
 PHONE: (501) 943-0468

TITLE: WATER DETAILS	
DESCRIPTION: BLOW-OFF ASSEMBLY	
DRAWN BY:	CHECKED BY:
FILE: W19-Blow-off Assembly.dwg	

DATE: APRIL 2015
REVISED

SHEET: **W19**

NOTES:

1. SWING CONNECTIONS USING 90° BENDS SHALL BE PERMITTED BY THE CITY ON A CASE BY CASE BASIS.
2. CONTRACTOR SHALL LOCATE EXISTING MAIN IN ADVANCE OF LAYING NEW LINE IN ORDER TO ASSURE ADEQUATE LENGTH TO ADJUST DEPTH OF NEW MAIN.
3. DIMENSIONS SHOWN ARE RECOMMENDED MINIMUMS TO PROVIDE ADEQUATE ROOM FOR TIGHTENING BOLTS ON JOINTS (OTHER DIMENSIONS MAY BE USED).
4. PROVIDE ALL THREAD STAINLESS STEEL TIE RODS WITH DUCTILE LUGS FOR ANCHORING ALL JOINTS.
5. ROTATE TEE UP & ELBOW DOWN AS REQUIRED TO MATCH.
6. TRACER WIRE SHALL BE INSTALLED ON ALL NEW WATER LINES.
7. ALL FITTINGS, VALVES, AND DIP SHALL BE POLY WRAPPED.

SCHEDULE OF TIE RODS		
SIZE	NUMBER OF ROD PER FITTING	DIAMETER OF S.S. RODS
8"	4	3/4"
12"	4	3/4"

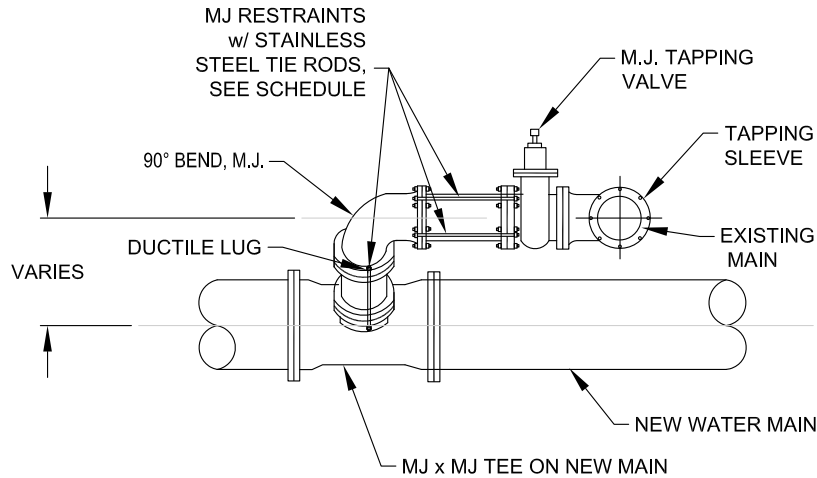

SECTION VIEW

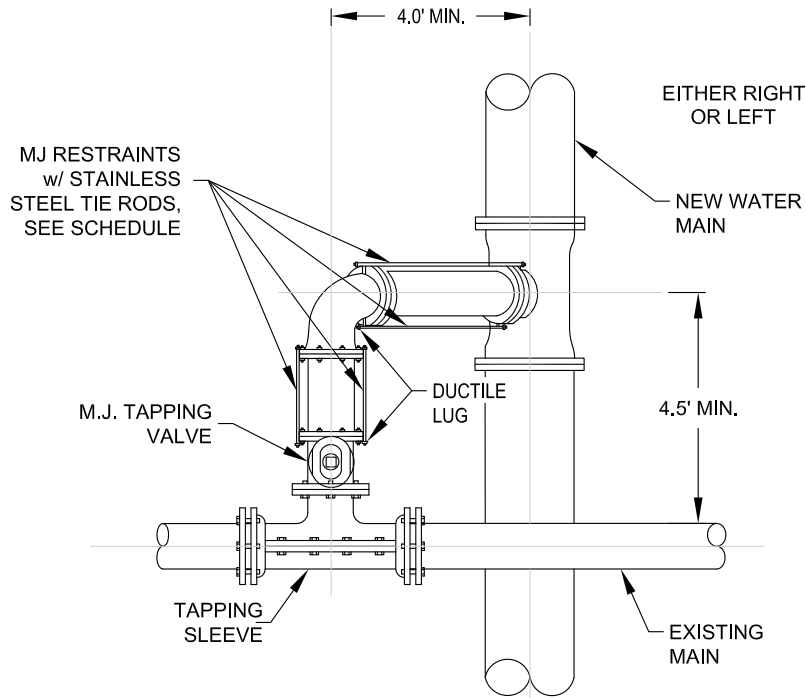

PLAN VIEW



CITY OF BRYANT, AR
 WATER UTILITIES
 210 S.W. 3rd. STREET
 BRYANT, AR
 PHONE: (501) 943-0468

TITLE: WATER DETAILS		
DESCRIPTION: SWING CONNECTION - NEW MAIN TO EXISTING MAIN		
DRAWN BY:	CHECKED BY:	FILE: W20-Swing Connection.dwg

DATE: APRIL 2015
REVISED

SHEET:
W20

NOTES:

1. ALL VALVES SHALL BE SECURELY ANCHORED.
2. ALL HARDWARE SHALL BE 316 STAINLESS STEEL.
3. IF DEPTH OF BURY EXCEEDS 4 FT., A VALVE STEM EXTENSION SHALL BE REQUIRED. THE VALVE STEM EXTENSION NUT SHALL BE WITHIN 24-INCHES TO 12-INCHES OF THE FINISHED SURFACE.

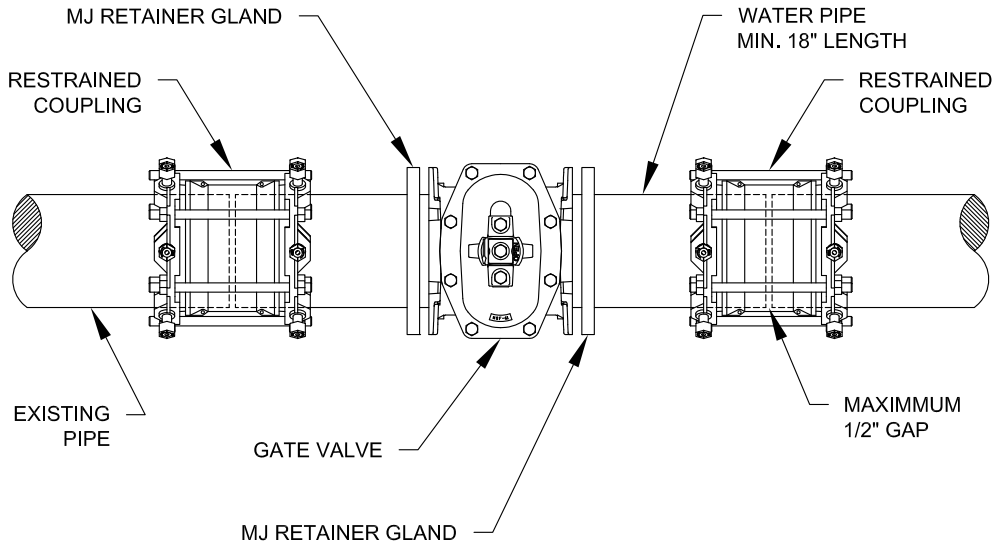

VALVE CUT-IN

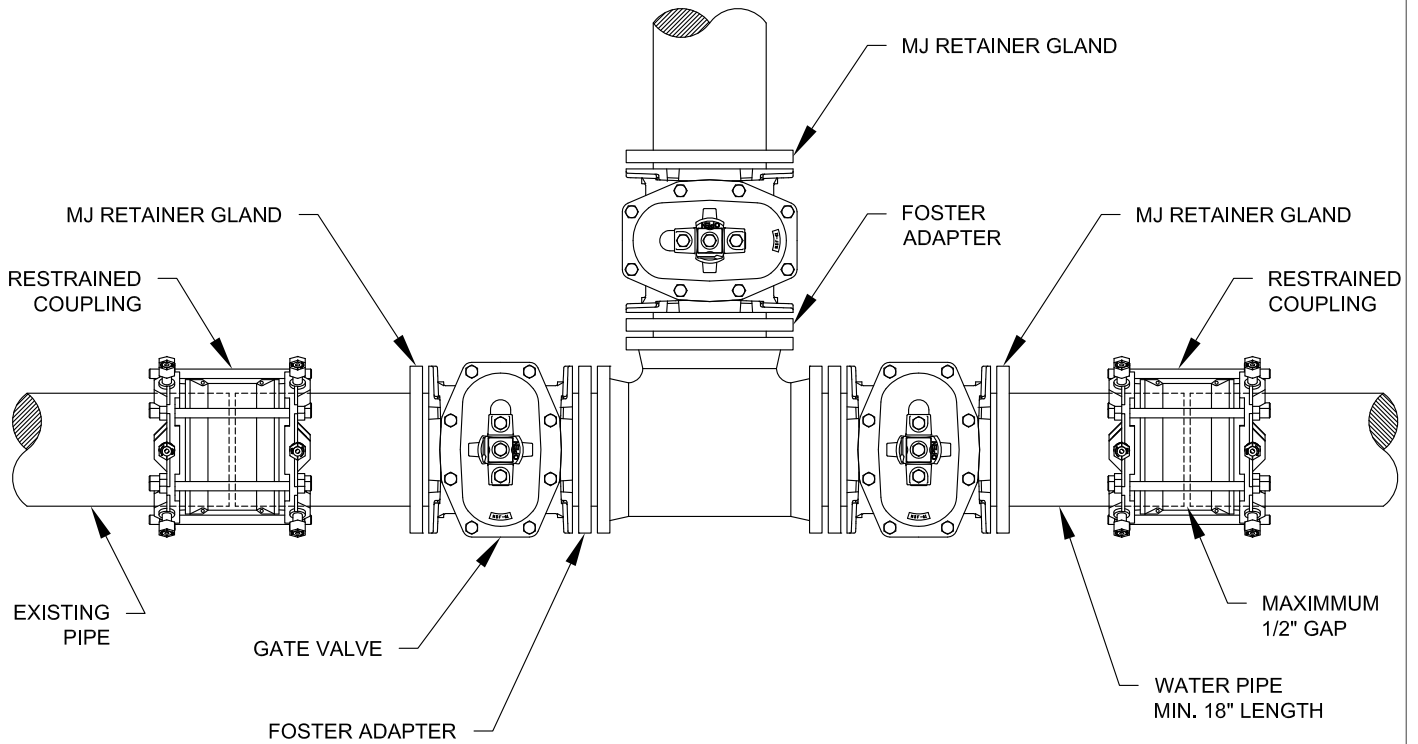

TEE AND VALVES CUT-IN



CITY OF BRYANT, AR
 WATER UTILITIES
 210 S.W. 3rd. STREET
 BRYANT, AR
 PHONE: (501) 943-0468

TITLE:	WATER DETAILS	
DESCRIPTION:	VALVE CUT-IN	
DRAWN BY:	CHECKED BY:	FILE: W21-Valve Cut In.dwg

DATE:	APRIL 2015
	REVISED

SHEET:
W21

NOTES:

1. WATER LINE MARKERS SHALL BE TRI-VIEW MARKING SYSTEM BY RHINO MARKING AND PROTECTION SYSTEMS OR CARSONITE INTERNATIONAL DUAL-SIDED UTILITY MARKER (CIB-380).
2. THE UPPERMOST PORTION OF THE CARSONITE MARKER SHALL BE MADE OF VISIBILITY ENHANCER (CVE-360).
3. TRI-VIEW MARKERS DO NOT REQUIRE VISIBILITY ENHANCERS.
4. AN ADDITIONAL WHITE 1" WIDE REFLECTIVE TAPE (3M OR EQUAL) SHALL BE PLACED AROUND THE FULL CIRCUMFERENCE OF THE TOP OF THE MARKER.

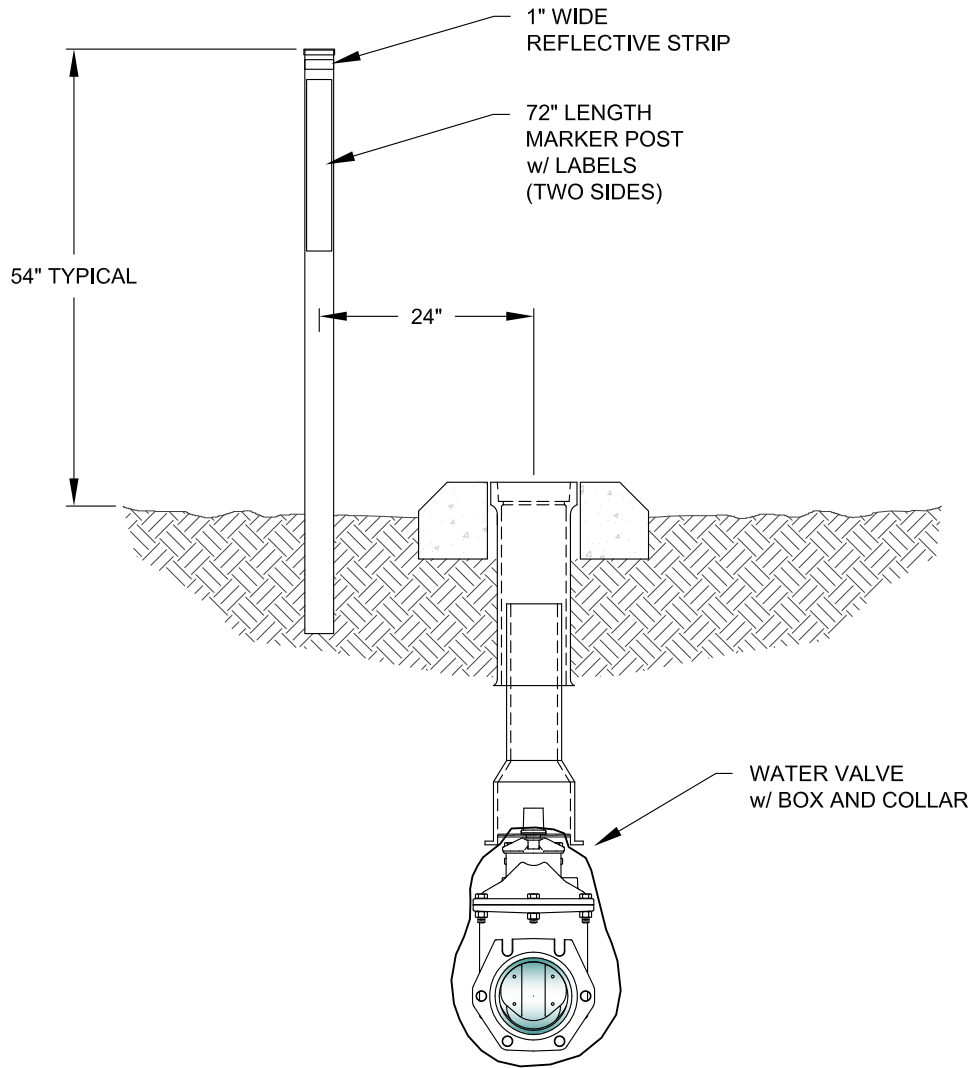

VALVE MARKER



CITY OF BRYANT, AR
 WATER UTILITIES
 210 S.W. 3rd. STREET
 BRYANT, AR
 PHONE: (501) 943-0468

TITLE:	WATER DETAILS	
DESCRIPTION:	VALVE MARKER	
DRAWN BY:	CHECKED BY:	FILE: W22-Valve Marker.dwg

DATE:	APRIL 2015
REVISED:	----

SHEET:
W22

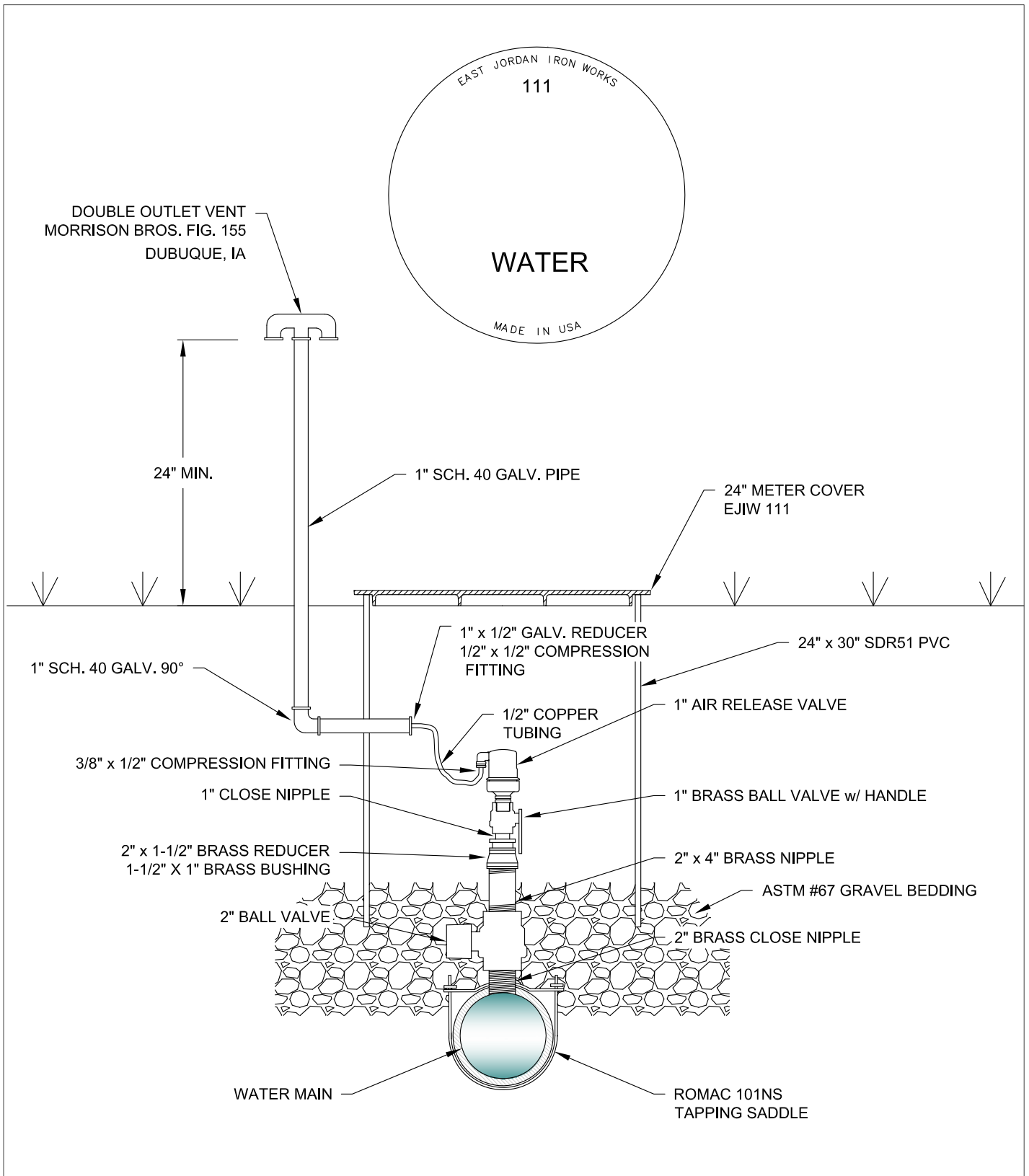

NOTES:

1. AIR VALVES SHALL HAVE NPT INLET AND OUTLETS.
2. TOP OF AIR VALVE SHALL BE MIN. 12" BELOW GROUND.
3. SEAL WALL PENETRATIONS WITH BUTYL SEALANT..

 <p>CITY OF BRYANT, AR WATER UTILITIES 210 S.W. 3rd. STREET BRYANT, AR PHONE: (501) 943-0468</p>	TITLE: WATER DETAILS		DATE: APRIL 2015	W23	
	DESCRIPTION: 1" COMBINATION AIR VALVE		REVISED		
	DRAWN BY:	CHECKED BY:	FILE: W23-1inch Air Release.dwg		----



DOUBLE OUTLET VENT
MORRISON BROS. FIG. 155
DUBUQUE, IA

24" MIN.

2" SCH. 40 GALV. PIPE

24" METER COVER
EJW 111

2" x 1-1/2"
SCH. 40 GALV. 90°

1-1/2" BRASS UNION

1-1/2" BRASS NIPPLE

24" x 30" SDR51 PVC

2" AIR RELEASE VALVE

2" BRASS BALL VALVE w/ HANDLE

2" x 4" BRASS NIPPLE

ASTM #67 GRAVEL BEDDING

2" BALL VALVE

2" BRASS CLOSE NIPPLE

WATER MAIN

ROMAC 101NS
TAPPING SADDLE

NOTES:

1. AIR VALVES SHALL HAVE NPT INLET AND OUTLETS.
2. TOP OF AIR VALVE SHALL BE MIN. 12" BELOW GROUND.
3. SEAL WALL PENETRATIONS WITH BUTYL SEALANT..



CITY OF BRYANT, AR
WATER UTILITIES
210 S.W. 3rd. STREET
BRYANT, AR
PHONE: (501) 943-0468

TITLE:	WATER DETAILS	
DESCRIPTION:	2" COMBINATION AIR VALVE	
DRAWN BY:	CHECKED BY:	FILE: W24-2inch Air Release.dwg

DATE:	APRIL 2015
	REVISED

SHEET:
W24



CITY OF BRYANT, AR
 WATER UTILITIES
 210 S.W. 3rd. STREET
 BRYANT, AR
 PHONE: (501) 943-0468

TITLE: WATER DETAILS		
DESCRIPTION: VERTICAL OFFSET		
DRAWN BY:	CHECKED BY:	FILE: W25-Vertical Offset.dwg

DATE:	APRIL 2015
REVISED	----
-----	----
-----	----
-----	----
-----	----

SHEET:
W25

NOTES:

1. THIS DETAIL IS FOR 12-INCH AND SMALLER WATER LINES. OTHER SIZES WILL HAVE TO HAVE A DETAILED DESIGN TO RESIST UPLIFT.
2. ALL PIPE AND FITTINGS SHALL BE FULLY RESTRAINED.
3. ALL HARDWARE SHALL BE 316 STAINLESS STEEL.
4. ALL DIP SHALL BE POLY WRAPPED.
5. ENCASEMENT IS REQUIRED IF WATER LINE HAS TO GO UNDER A SEWER LINE. ENCASEMENT SHALL EXTEND A MINIMUM OF 10' PAST THE EITHER EDGE OF THE SEWER LINE.

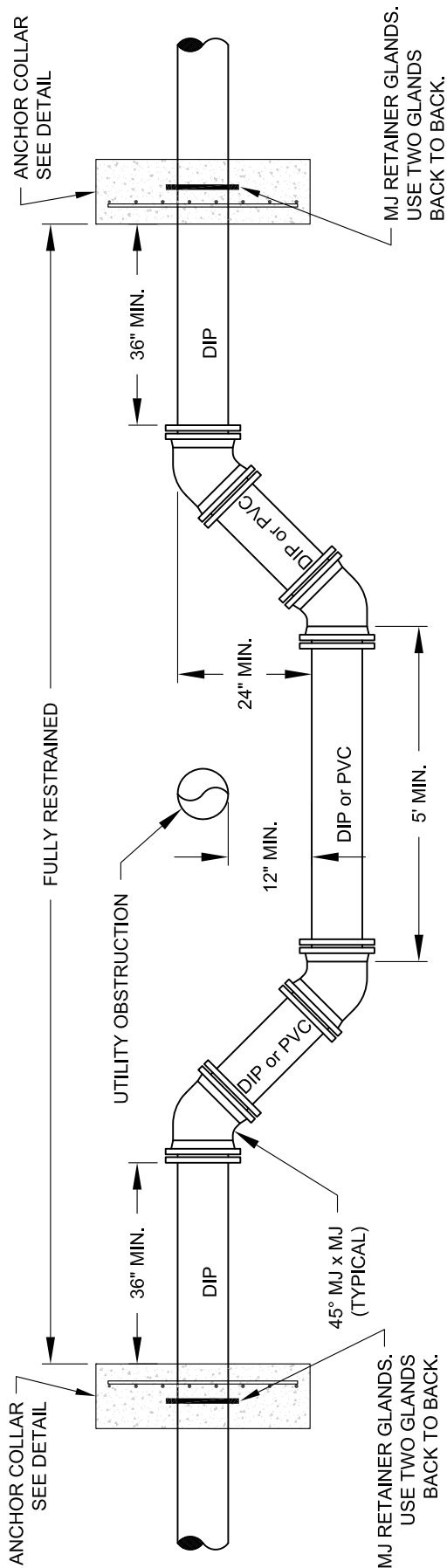

VERTICAL OFFSET

NOTE:

RESTRAINED COUPLINGS SHALL BE USED WHEN JOINING TWO CUT PIECES OF PIPE, GENERALLY WHEN CUTTING IN VALVES AND TEES.

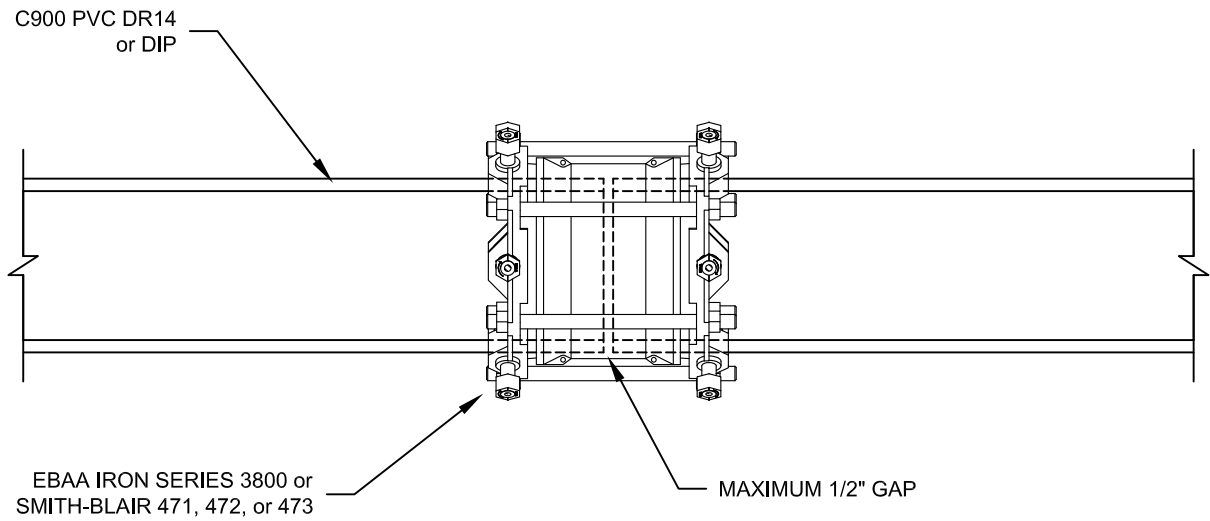

RESTRAINED COUPLING



CITY OF BRYANT, AR
WATER UTILITIES
210 S.W. 3rd. STREET
BRYANT, AR
PHONE: (501) 943-0468

TITLE:	WATER DETAILS	
DESCRIPTION:	RESTRAINED COUPLING	
DRAWN BY:	CHECKED BY:	FILE: W26--Restrained Coupling.dwg

DATE:	APRIL 2015
REVISED	----

SHEET:
W26

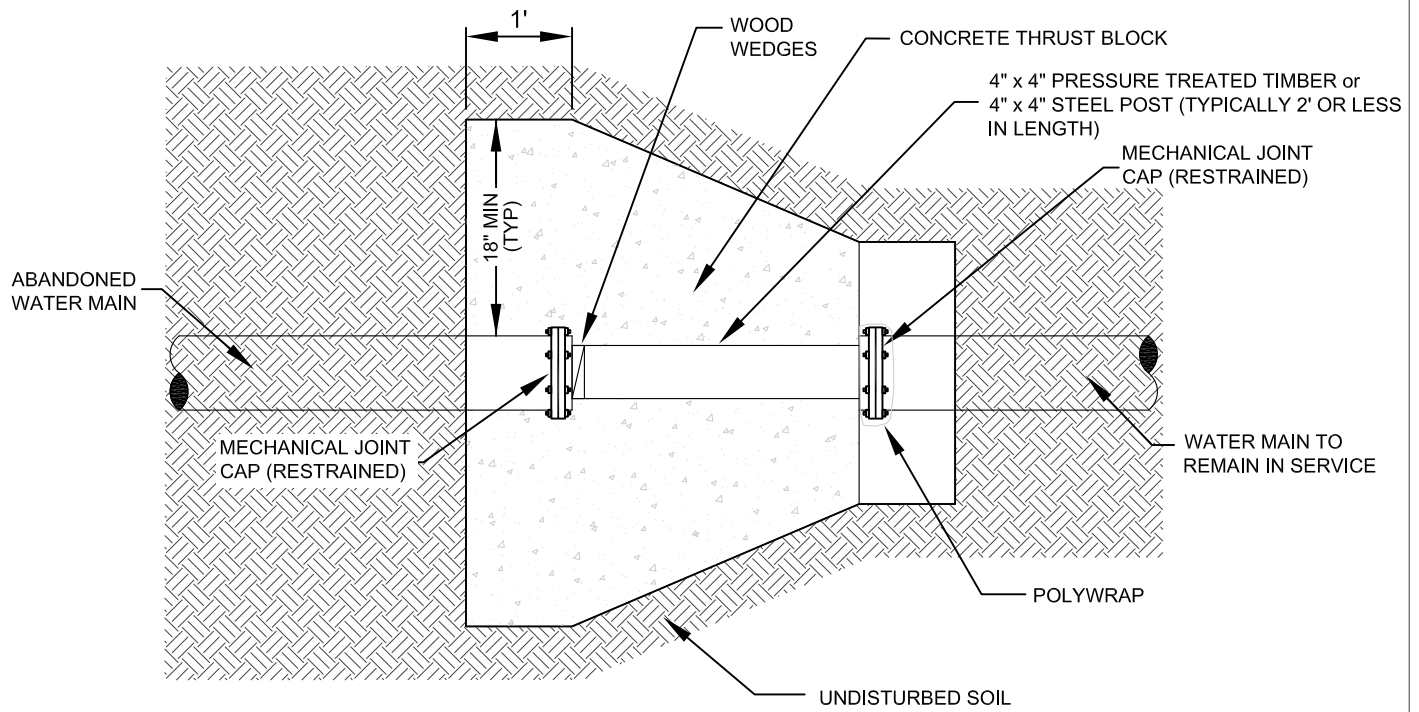

PLAN VIEW

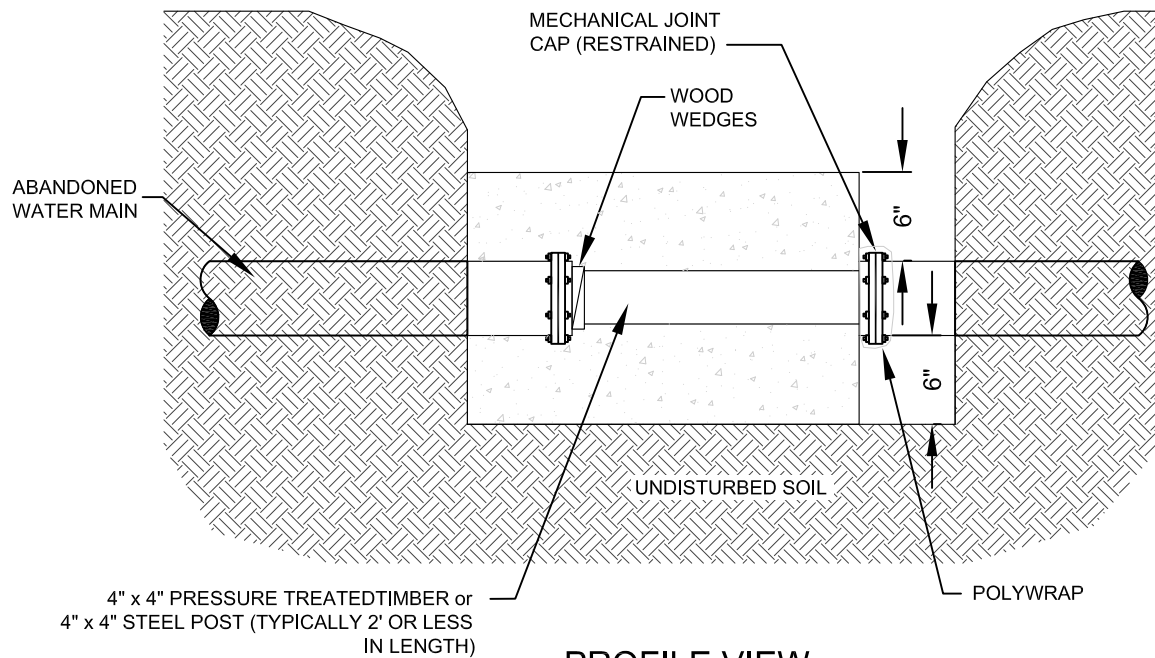

PROFILE VIEW

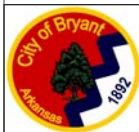

CITY OF BRYANT, AR
 WATER UTILITIES
 210 S.W. 3rd. STREET
 BRYANT, AR
 PHONE: (501) 943-0468

TITLE:	WATER DETAILS	
DESCRIPTION:	CUT AND CAP WATER LINE	
DRAWN BY:	CHECKED BY:	FILE: W27-Cut and Cap.dwg

DATE:	APRIL 2015
	REVISED

SHEET:
W27

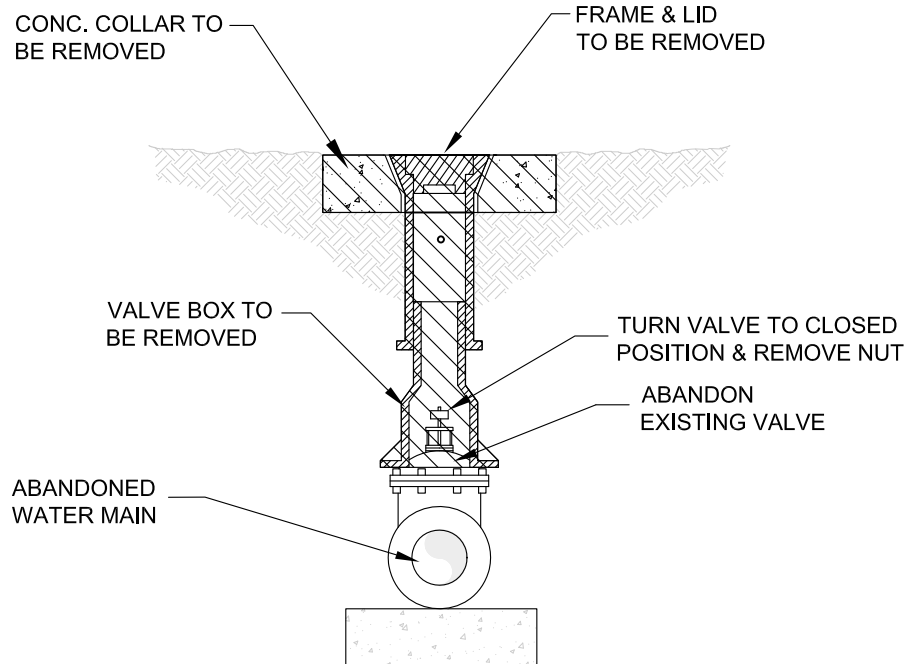

ABANDON WATER VALVE

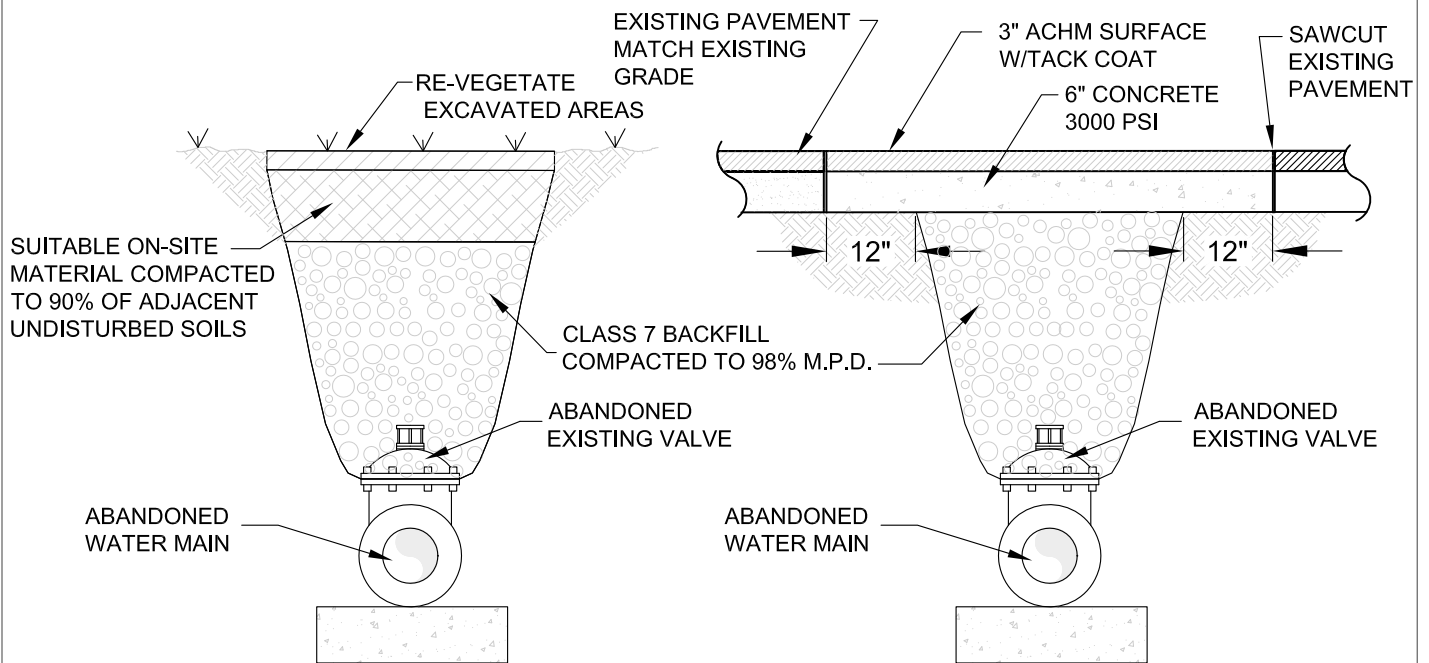

TRENCH AFTER VALVE BOX REMOVED (NON-PAVED AREA)

TRENCH AFTER VALVE BOX REMOVED (UNDER ASPHALT)



CITY OF BRYANT, AR
 WATER UTILITIES
 210 S.W. 3rd. STREET
 BRYANT, AR
 PHONE: (501) 943-0468

TITLE:	WATER DETAILS		
DESCRIPTION:	ABANDON WATER VALVE		
DRAWN BY:	CHECKED BY:	FILE:	W28-Abandon Water Valve.dwg

DATE:	APRIL 2015
	REVISED

SHEET:
W28

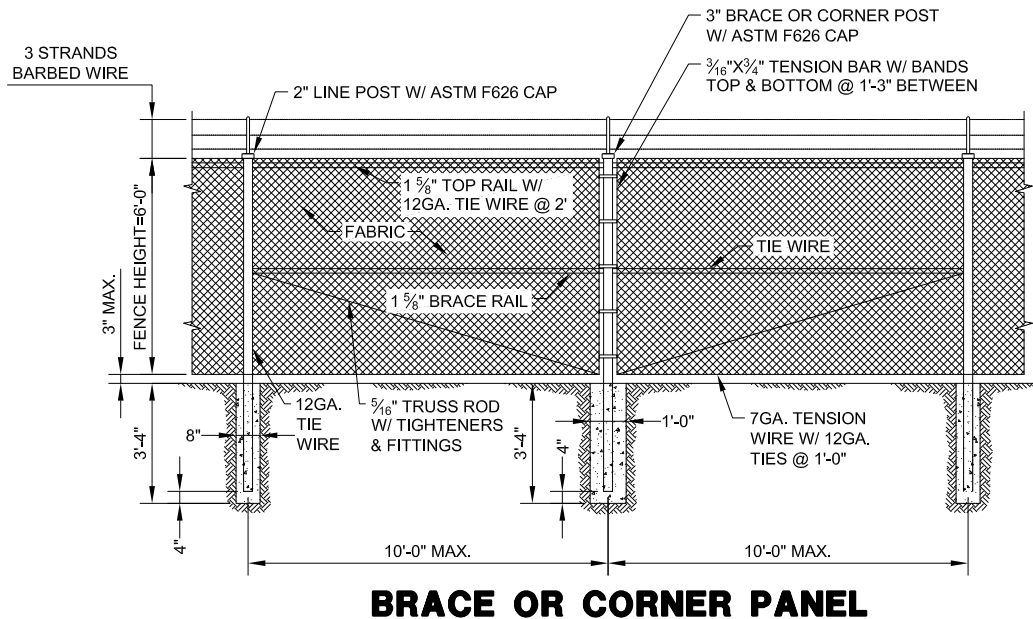
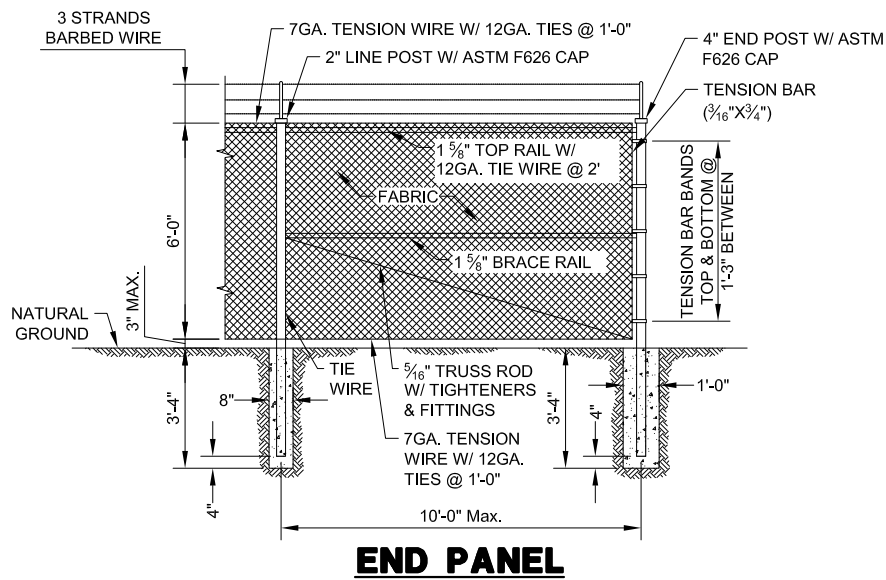
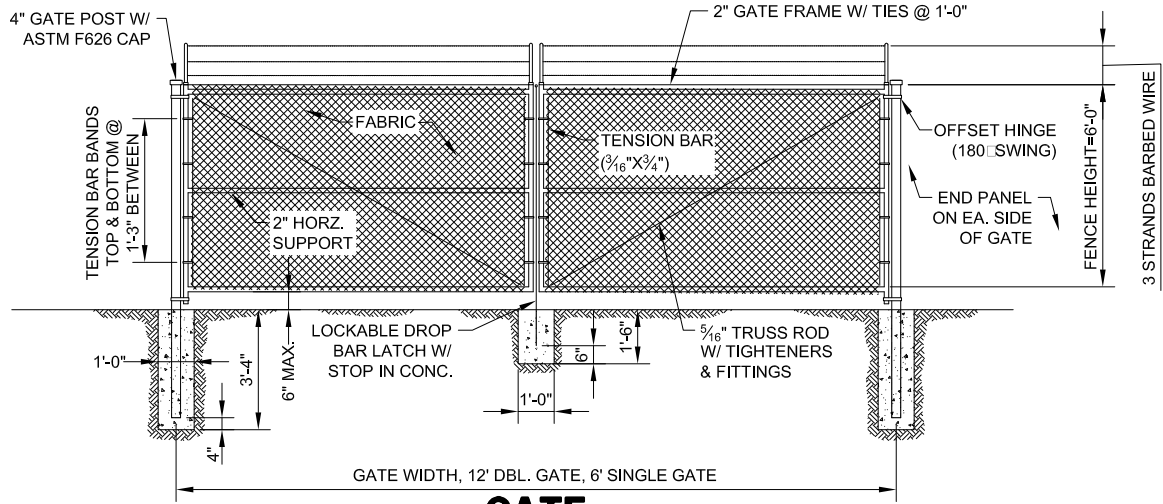

CITY OF BRYANT, AR
 WATER UTILITIES
 210 S.W. 3rd. STREET
 BRYANT, AR
 PHONE: (501) 943-0468

TITLE:	WATER DETAILS	
DESCRIPTION:	CHAIN LINK FENCE DETAILS	
DRAWN BY: ???	CHECKED BY: ???	FILE: W29-Chain Link Fence Details.dwg

DATE:	Sept. 10, 2014
REVISED:	----
REVISED:	----
REVISED:	----
REVISED:	----

SHEET:
W29

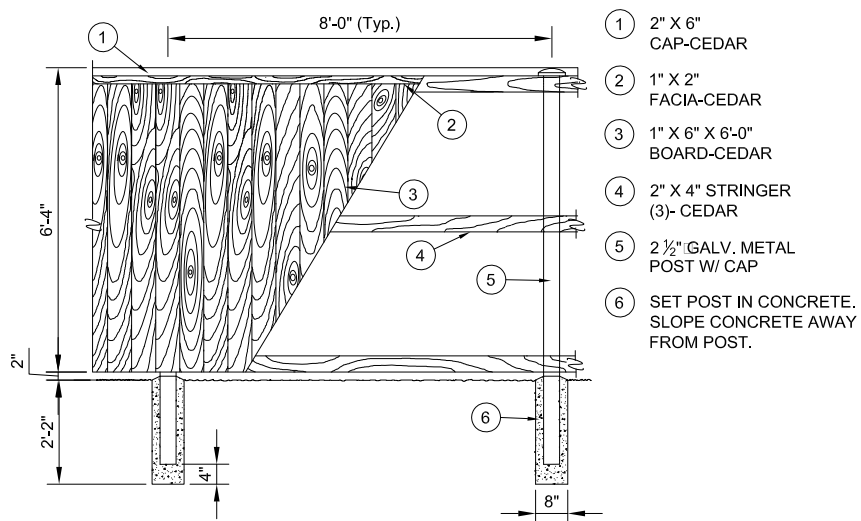

BOARD & BATT CEDAR FENCE



CITY OF BRYANT, AR
 WATER UTILITIES
 210 S.W. 3rd. STREET
 BRYANT, AR
 PHONE: (501) 943-0468

TITLE:	WATER DETAILS	
DESCRIPTION:	WOOD FENCE DETAIL	
DRAWN BY:	CHECKED BY:	FILE: W29_W30-Fence Details.dwg

DATE:	APRIL 2015
REVISED	----

SHEET:
W30

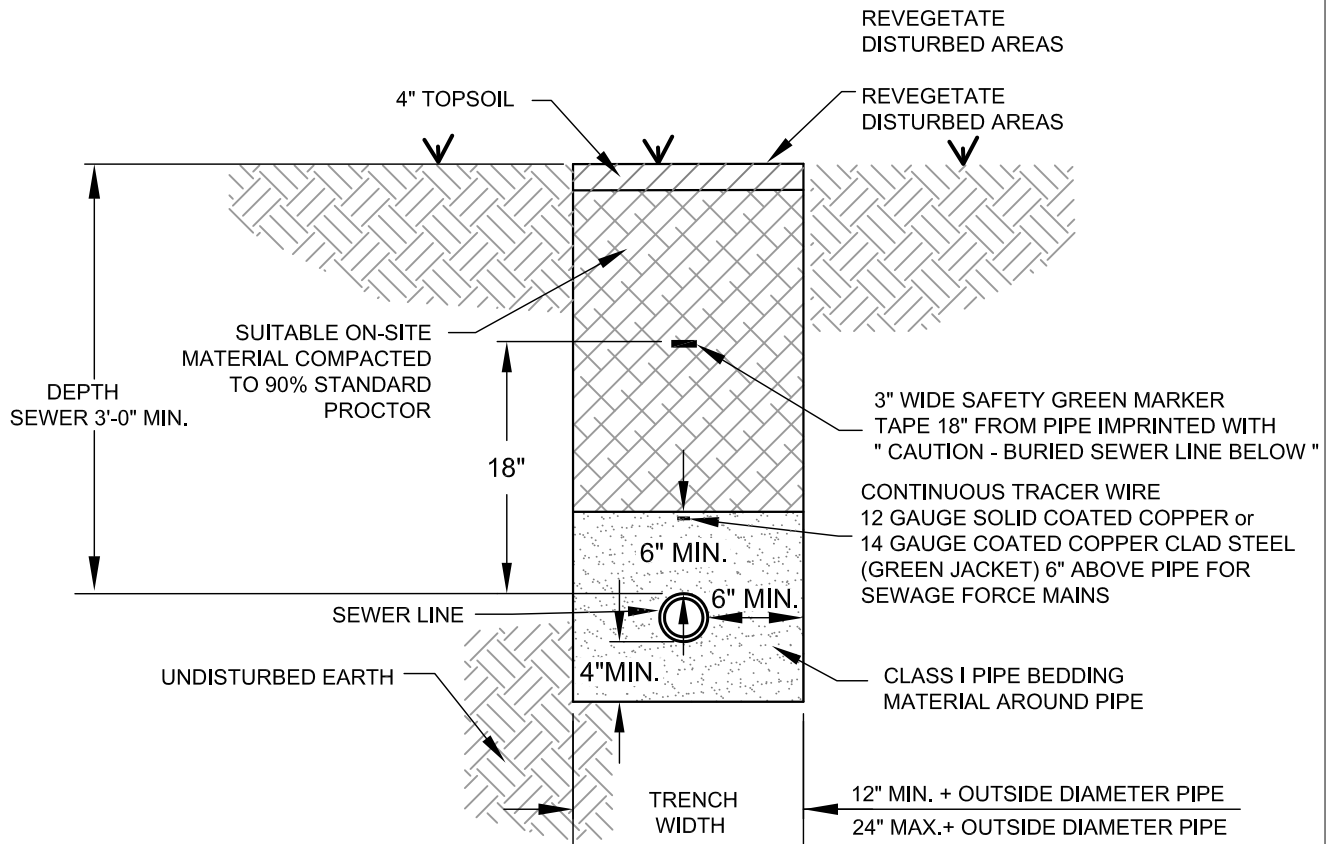

NOTES:

1. THE CONTRACTOR SHALL PROVIDE ALL ITEMS NECESSARY TO CONNECT WITH ANY PART OF THE EXISTING SEWER SYSTEM THAT WILL REMAIN IN ORDER TO ESTABLISH A SATISFACTORY AND ACCEPTABLE SEWER SYSTEM.
2. CONTRACTOR TO CONSTRUCT ALL TRENCH EXCAVATION IN ACCORDANCE WITH ALL OSHA REGULATIONS (29 CFR CH.XVII, SUBPART B)
3. TRENCH SHALL BE EXCAVATED BELOW GRADE REQUIRED TO PROVIDE A MINIMUM 36" OF PIPE COVER.

SEWER TRENCH

(NON-PAVED AREA)



CITY OF BRYANT, AR
 WATER UTILITIES
 210 S.W. 3rd. STREET
 BRYANT, AR
 PHONE: (501) 943-0468

TITLE: SEWER DETAILS	
DESCRIPTION: SEWER TRENCH (NON-PAVED AREA)	
DRAWN BY:	CHECKED BY:
FILE: S1-Sewer Trench (Non-Paved Area).dwg	

DATE: APRIL 2015
REVISED

SHEET:
S1

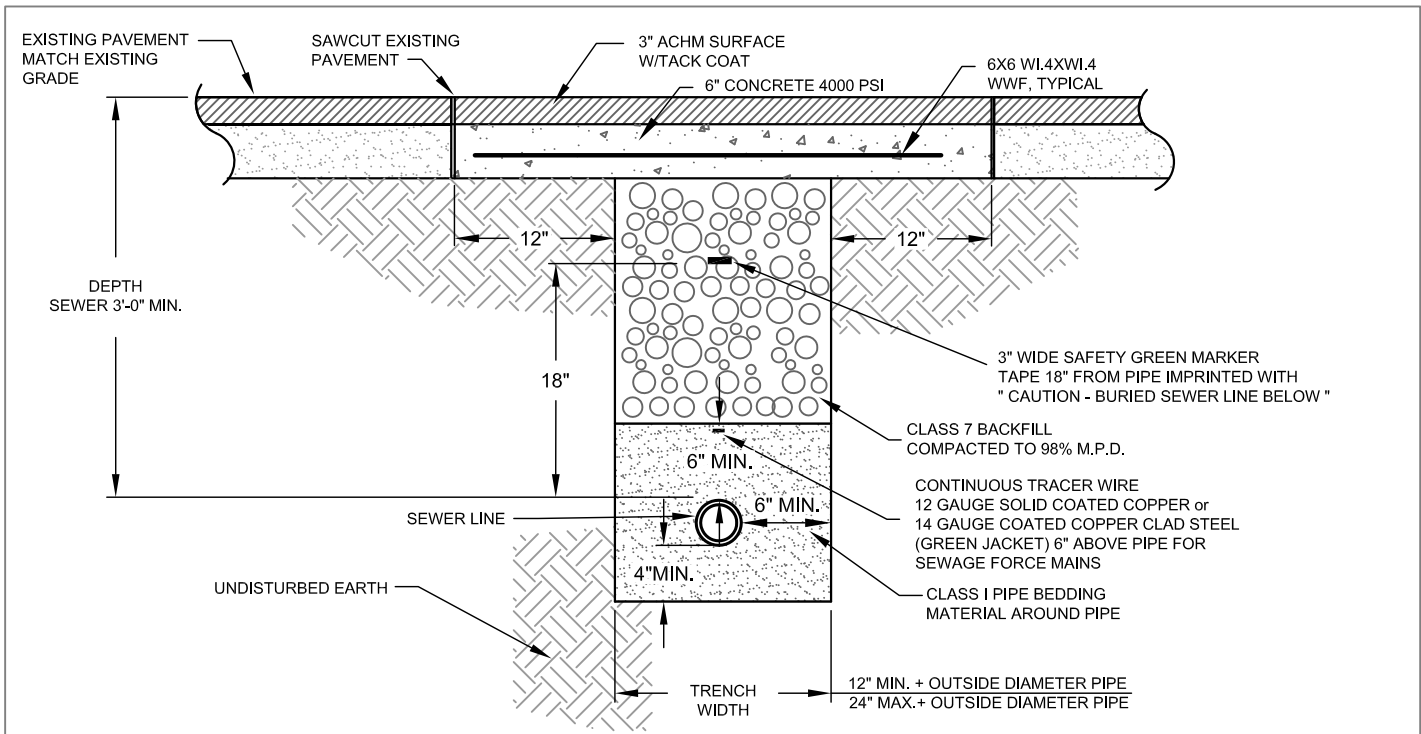

SEWER TRENCH
(UNDER ASPHALT)

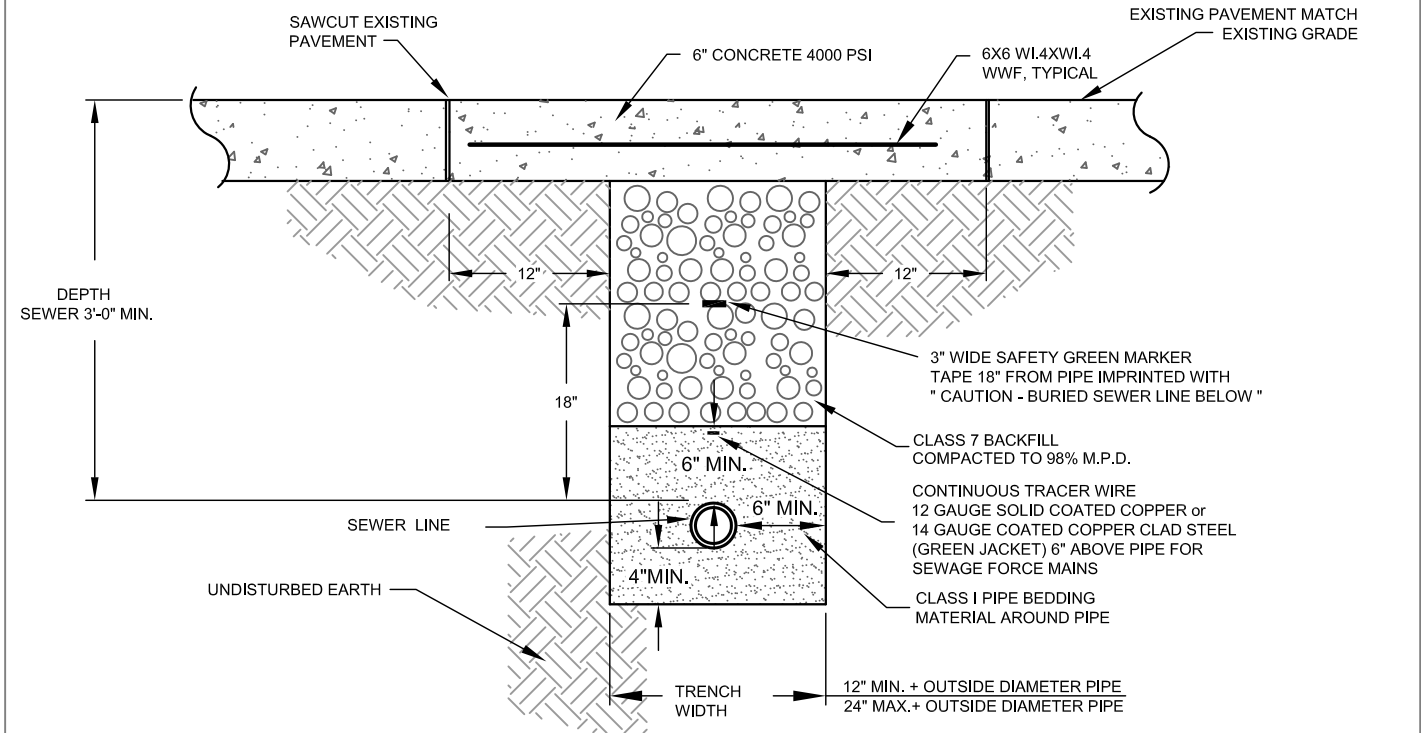

SEWER TRENCH
(UNDER CONCRETE)

NOTES:

1. THE CONTRACTOR SHALL PROVIDE ALL ITEMS NECESSARY TO CONNECT WITH ANY PART OF THE EXISTING SEWER SYSTEM THAT WILL REMAIN IN ORDER TO ESTABLISH A SATISFACTORY AND ACCEPTABLE SEWER SYSTEM.
2. CONTRACTOR TO CONSTRUCT ALL TRENCH EXCAVATION IN ACCORDANCE WITH ALL OSHA REGULATIONS (29 CFR CH.XVII, SUBPART B)
3. TRENCH SHALL BE EXCAVATED BELOW GRADE REQUIRED TO PROVIDE A MINIMUM 36" OF PIPE COVER.



CITY OF BRYANT, AR
WATER UTILITIES
210 S.W. 3rd. STREET
BRYANT, AR
PHONE: (501) 943-0468

TITLE:	SEWER DETAILS	
DESCRIPTION:	SEWER TRENCH (UNDER PAVEMENT)	
DRAWN BY:	CHECKED BY:	FILE: S2-Sewer Trench (Under Pavement).dwg

DATE:	APRIL 2015
	REVISED

SHEET:
S2

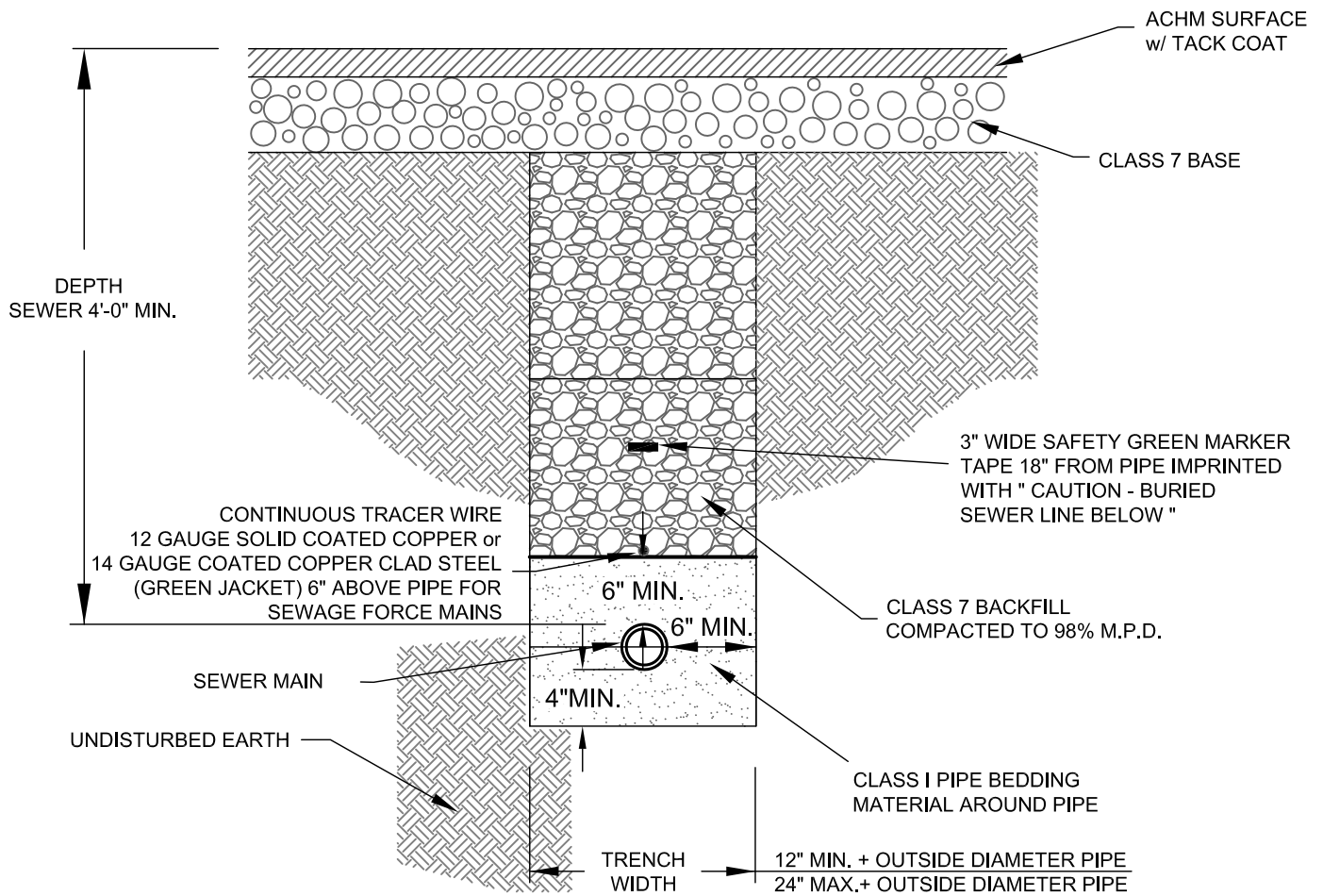

SEWER MAIN INSTALLATION PRIOR TO ROADWAY CONSTRUCTION

NOTES:

1. THE CONTRACTOR SHALL PROVIDE ALL ITEMS NECESSARY TO CONNECT WITH ANY PART OF THE EXISTING SEWER SYSTEM THAT WILL REMAIN IN ORDER TO ESTABLISH A SATISFACTORY AND ACCEPTABLE SEWER SYSTEM.
2. CONTRACTOR TO CONSTRUCT ALL TRENCH EXCAVATION IN ACCORDANCE WITH ALL OSHA REGULATIONS (29 CFR CH.XVII, SUBPART B)
3. TRENCH SHALL BE EXCAVATED BELOW GRADE REQUIRED TO PROVIDE A MINIMUM 36" OF PIPE COVER.



CITY OF BRYANT, AR
 WATER UTILITIES
 210 S.W. 3rd. STREET
 BRYANT, AR
 PHONE: (501) 943-0468

TITLE:	SEWER DETAILS	
DESCRIPTION:	SEWER MAIN INSTALLATION PRIOR TO ROADWAY CONSTRUCTION	
DRAWN BY:	CHECKED BY:	FILE: S3-Sewer Main Installation Prior to Roadway Const.dwg----

DATE:	APRIL 2015
	REVISED

SHEET:
S3

Inside Diameter of Manhole	Minimum Wall Thickness	Base Thickness	Minimum Ring & Cover Size
4' DIA	6"	6"	24" (≤ or Equal to 24" Pipes)
5' DIA	8"	8"	
6' DIA	8"	12"	36" (> 24" Pipes)

MANHOLE INFORMATION TABLE

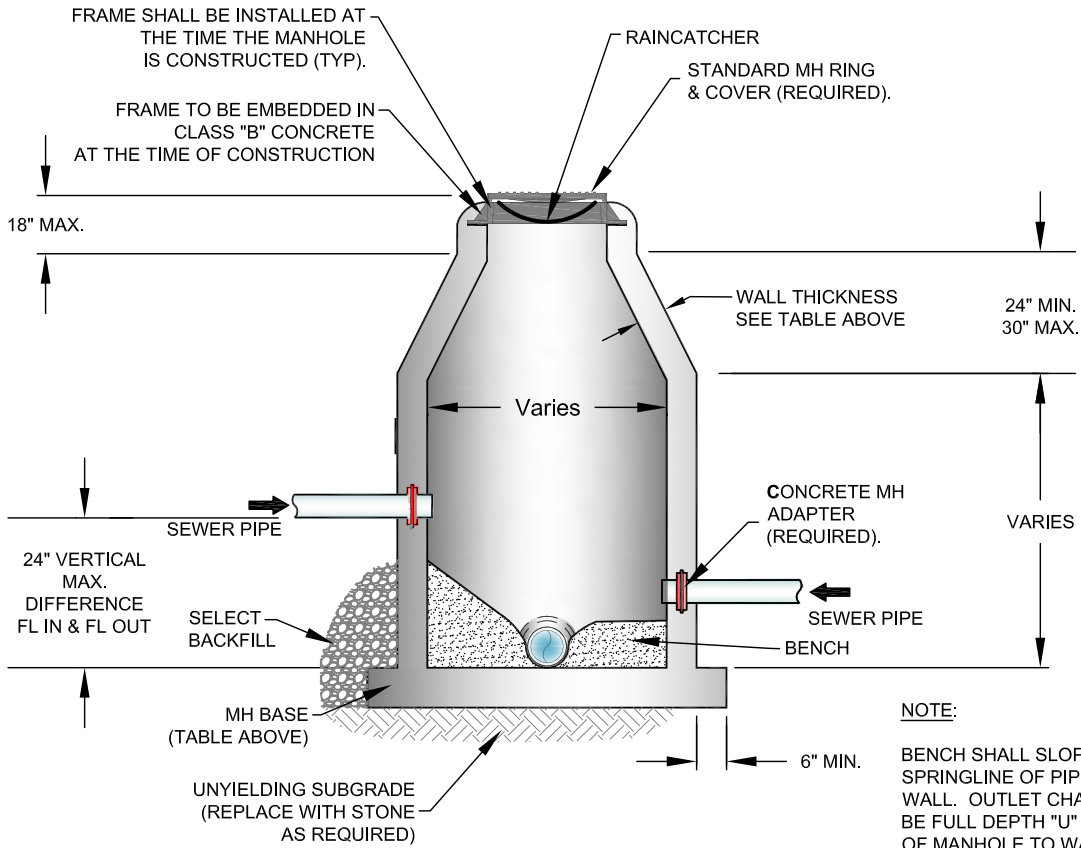
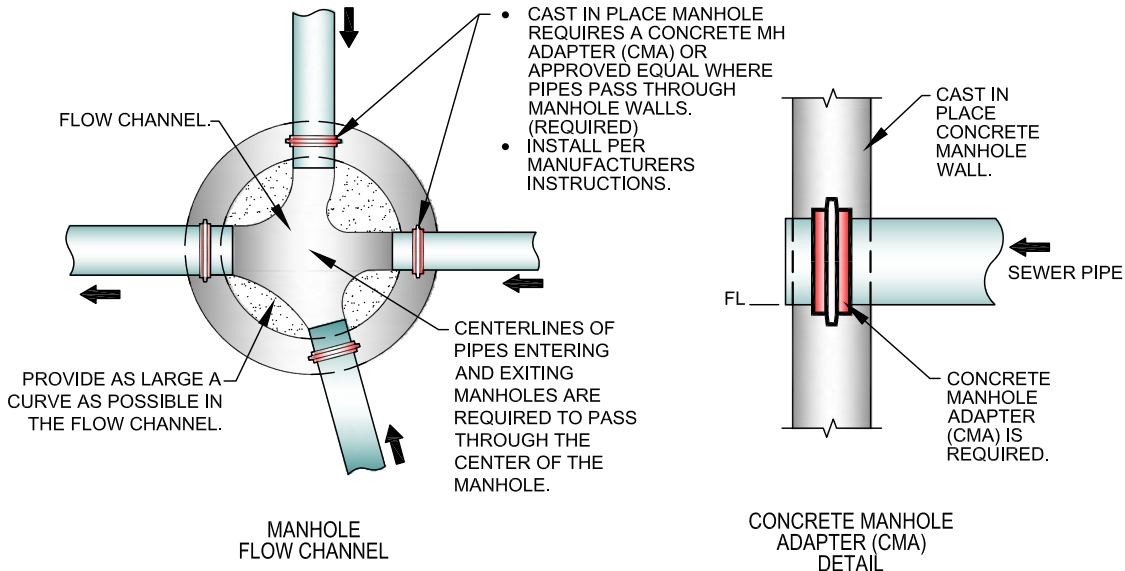

CAST-IN-PLACE MANHOLE

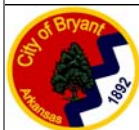

CITY OF BRYANT, AR
 WATER UTILITIES
 210 S.W. 3rd. STREET
 BRYANT, AR
 PHONE: (501) 943-0468

TITLE:	SEWER DETAILS	
DESCRIPTION:	CAST-IN-PLACE MANHOLE	
DRAWN BY:	CHECKED BY:	FILE: S4-Cast In Place Manhole.dwg

DATE:	APRIL 2015
	REVISED

SHEET:
S4

Inside Diameter of Manhole	Minimum Wall Thickness	Base Thickness	Minimum Ring & Cover Size
4' DIA	5"	6"	24" (< or Equal to 24" Pipes)
5' DIA	7"	8"	
6' DIA	7"	8"	36" (> 24" Pipes)

MANHOLE INFORMATION TABLE

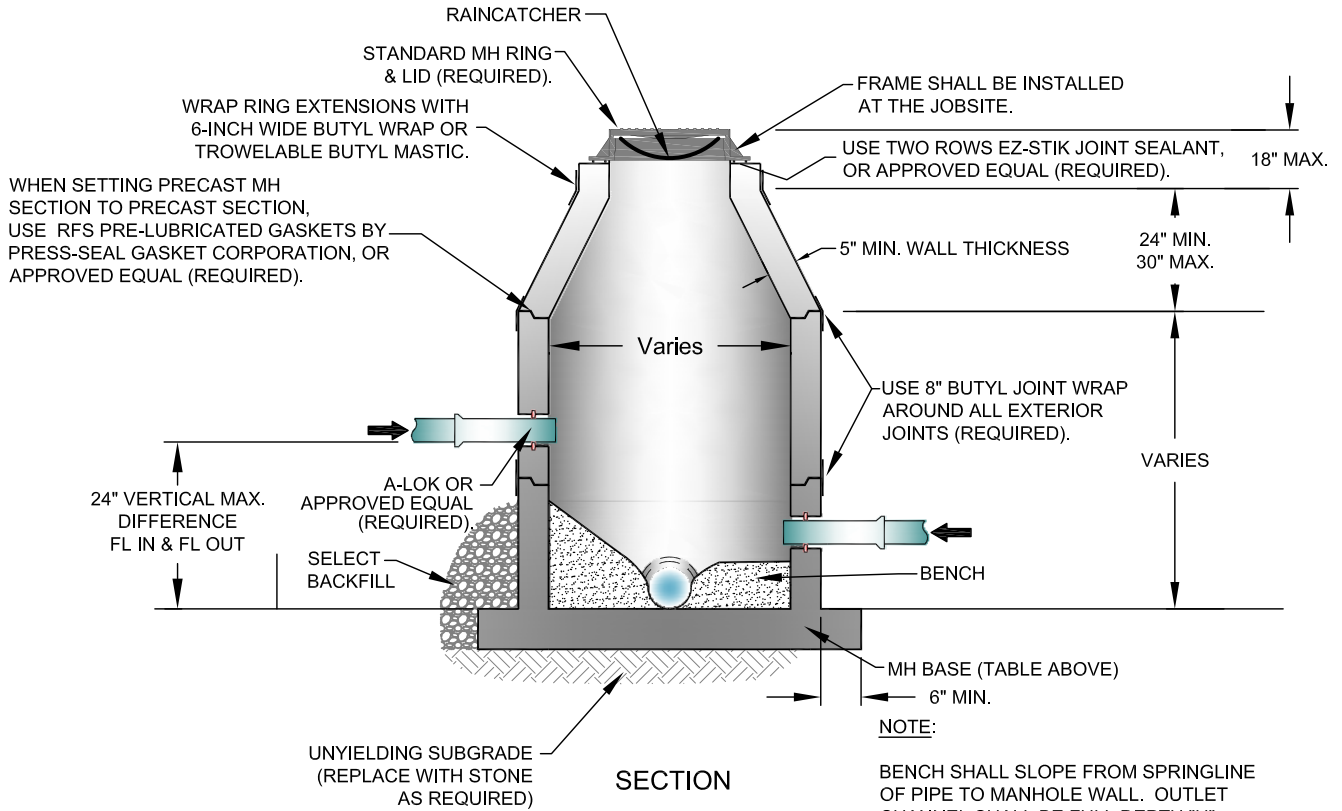
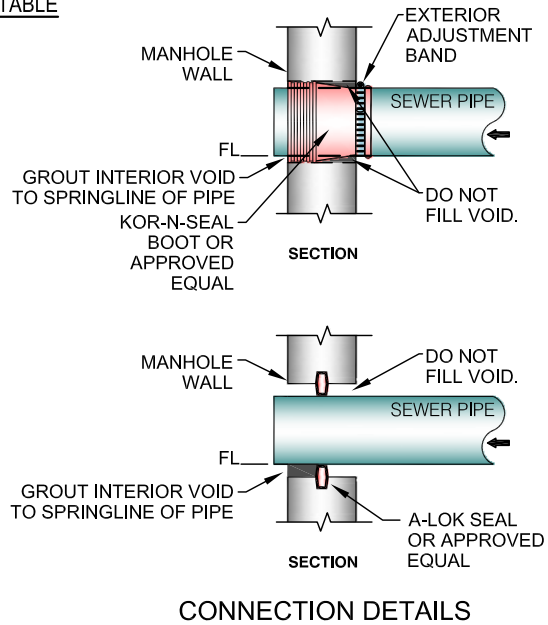
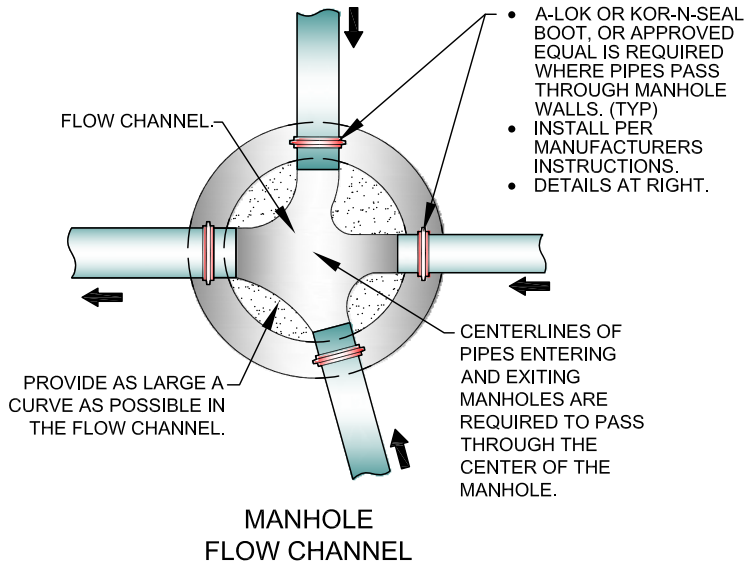

PRECAST MANHOLE



CITY OF BRYANT, AR
 WATER UTILITIES
 210 S.W. 3rd. STREET
 BRYANT, AR
 PHONE: (501) 943-0468

TITLE:	SEWER DETAILS	
DESCRIPTION:	PRECAST MANHOLE	
DRAWN BY:	CHECKED BY:	FILE: S5-Precast Manhole.dwg

DATE:	APRIL 2015
	REVISED

SHEET: **S5**

ALL CASTINGS SHALL BE "MADE IN USA"

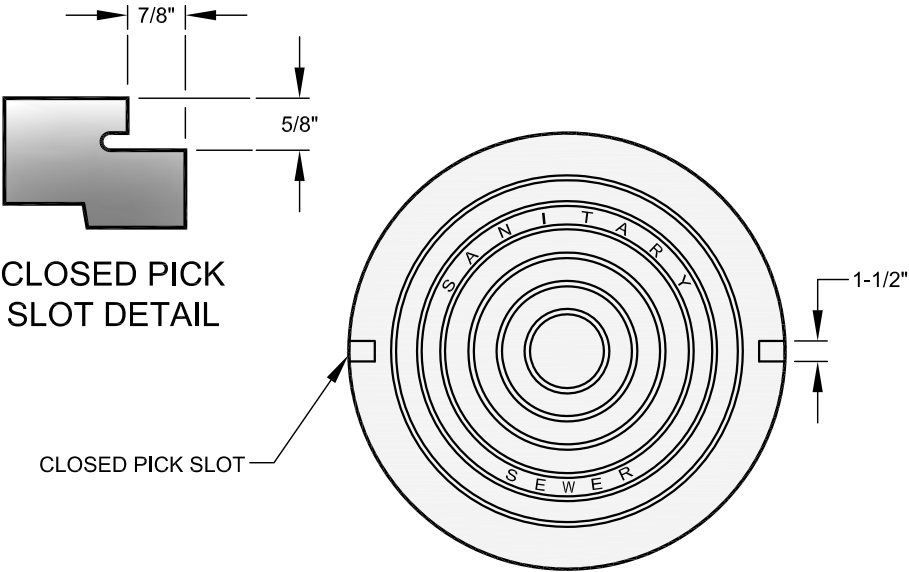

COVER DETAIL

1. MINIMUM WEIGHT OF RING: 100 POUNDS
2. MINIMUM WEIGHT OF COVER: 110 POUNDS
3. COVERS ARE FURNISHED WITH TWO CLOSED PICK SLOTS.
4. CASTINGS SHALL BE "MADE IN USA"

* DIMENSIONAL TOLERANCES SHALL NOT EXCEED 1/16 INCH PER FOOT

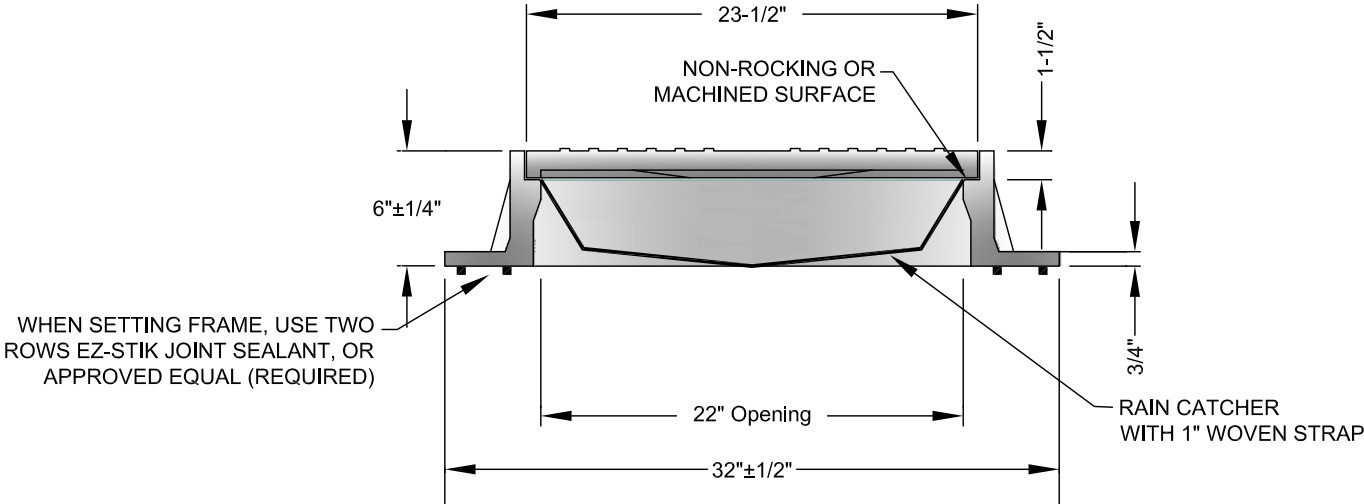

FRAME AND COVER DETAIL



CITY OF BRYANT, AR
 WATER UTILITIES
 210 S.W. 3rd. STREET
 BRYANT, AR
 PHONE: (501) 943-0468

TITLE:	SEWER DETAILS	
DESCRIPTION:	MANHOLE FRAME AND COVER	
DRAWN BY:	CHECKED BY:	FILE: S6-Manhole Frame and Cover.dwg

DATE:	APRIL 2015
REVISED:	----

SHEET:
S6

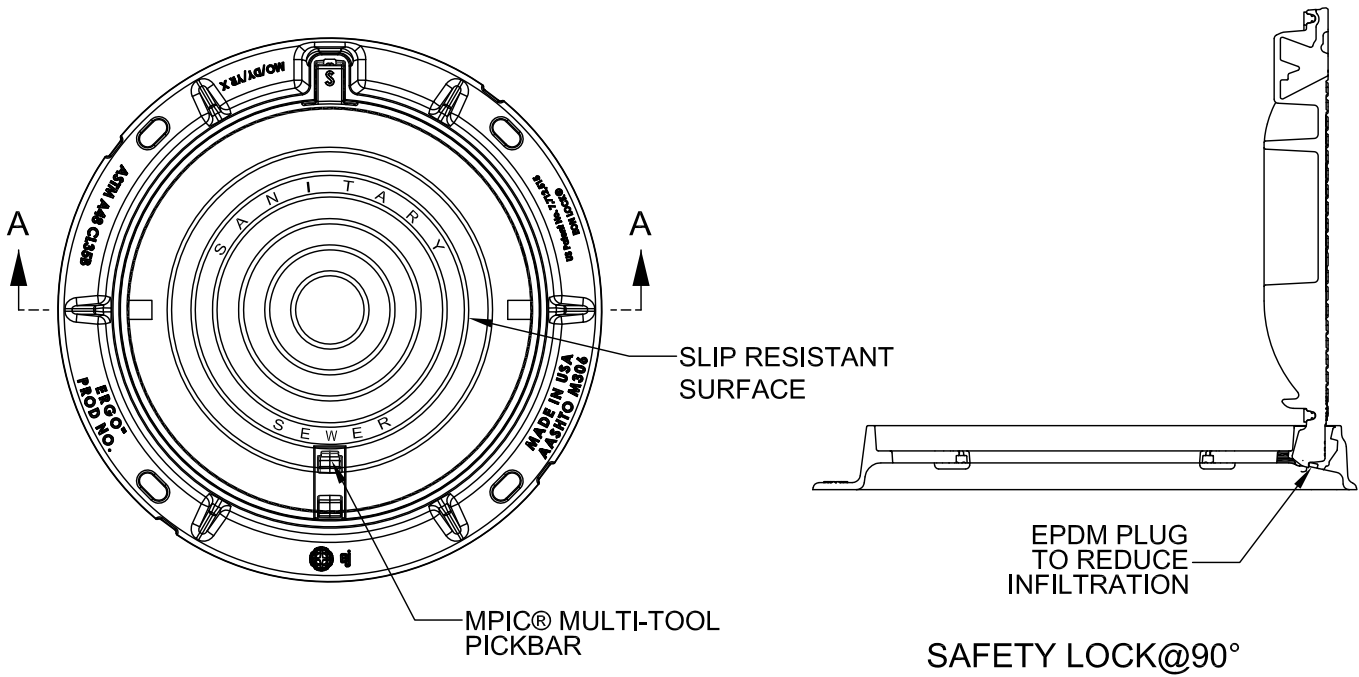

SAFETY LOCK@90°

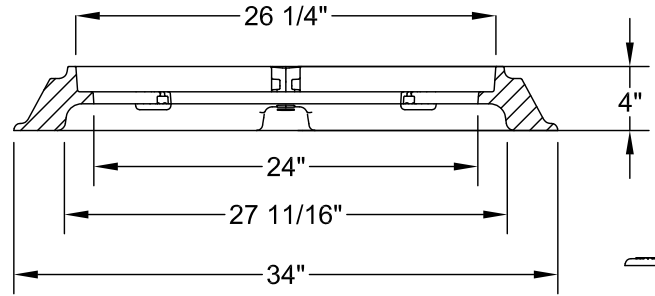
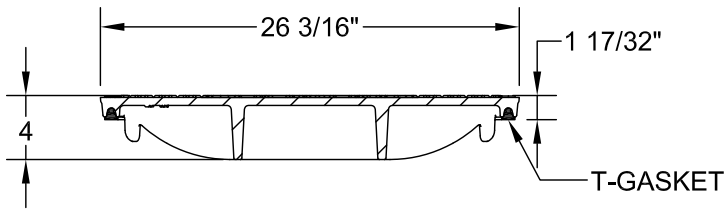

SECTION A-A

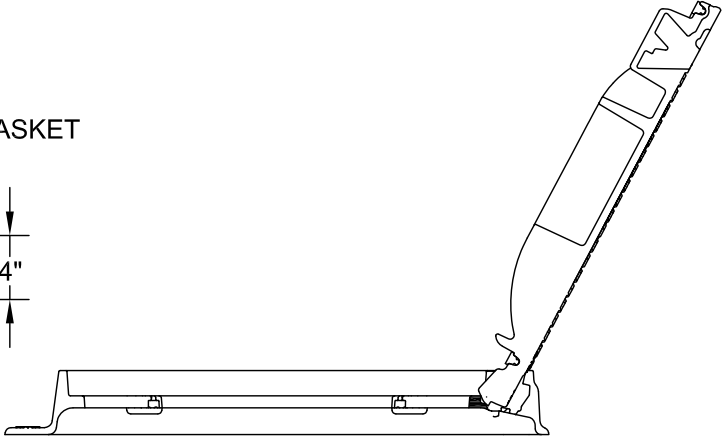

FULLY OPENED@120°

HINGED FRAME AND COVER DETAIL



CITY OF BRYANT, AR
 WATER UTILITIES
 210 S.W. 3rd. STREET
 BRYANT, AR
 PHONE: (501) 943-0468

TITLE:	HINGED MANHOLE FRAME AND COVER	
DESCRIPTION:	HINGED MANHOLE FRAME AND COVER	
DRAWN BY:	CHECKED BY:	FILE: S7-Hinged Manhole Frame and Cover-OLD.dwg

DATE:	APRIL 2015
	REVISED

SHEET:
S7

CITY OF BRYANT
STANDARD FRAME & COVER

(4) CLOSED PICKHOLES

(1) PICKBAR

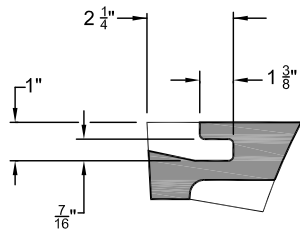

PICKHOLE DETAIL

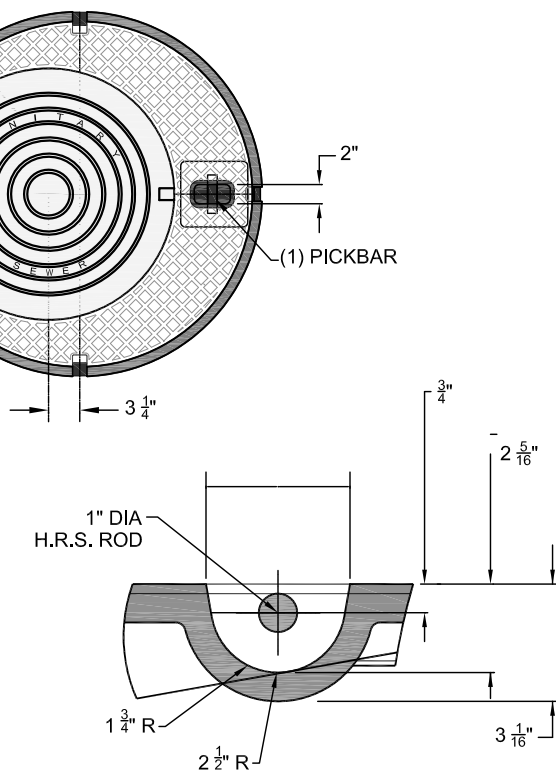

PICKBAR DETAIL

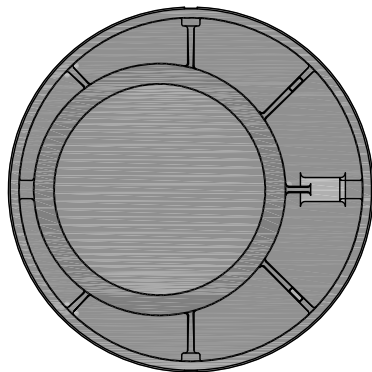

COVER BACK

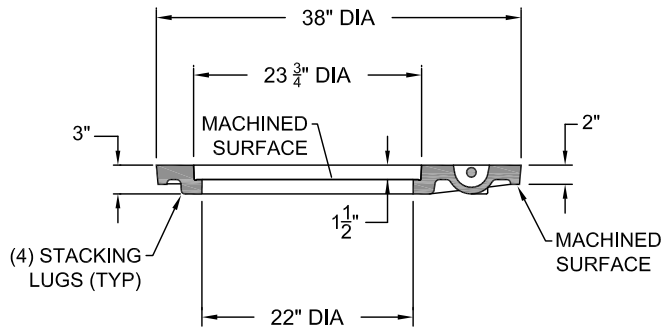

COVER SECTION

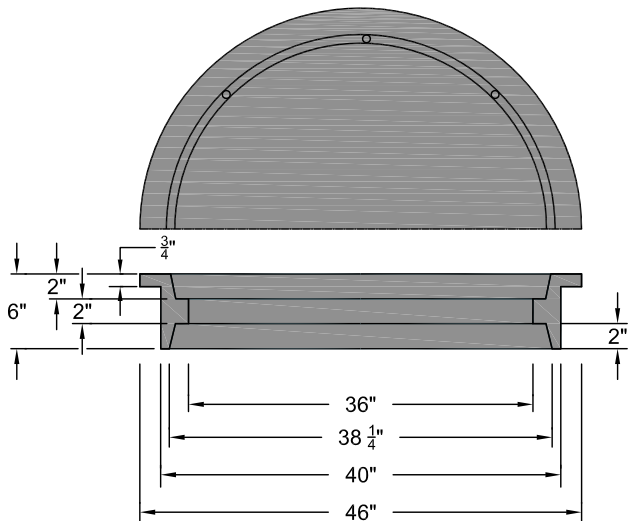

REVERSIBLE
FRAME

EST.
WEIGHT 360
POUNDS

NOTE:

ALL CASTINGS SHALL BE "MADE IN USA"



CITY OF BRYANT, AR
WATER UTILITIES
210 S.W. 3rd. STREET
BRYANT, AR
PHONE: (501) 943-0468

TITLE:	SEWER DETAILS	
DESCRIPTION:	36-INCH MANHOLE FRAME AND COVER	
DRAWN BY:	CHECKED BY:	FILE: S8-36 Inch Manhole Frame and Cover.dwg

DATE:	APRIL 2015
	REVISED

SHEET:
S8

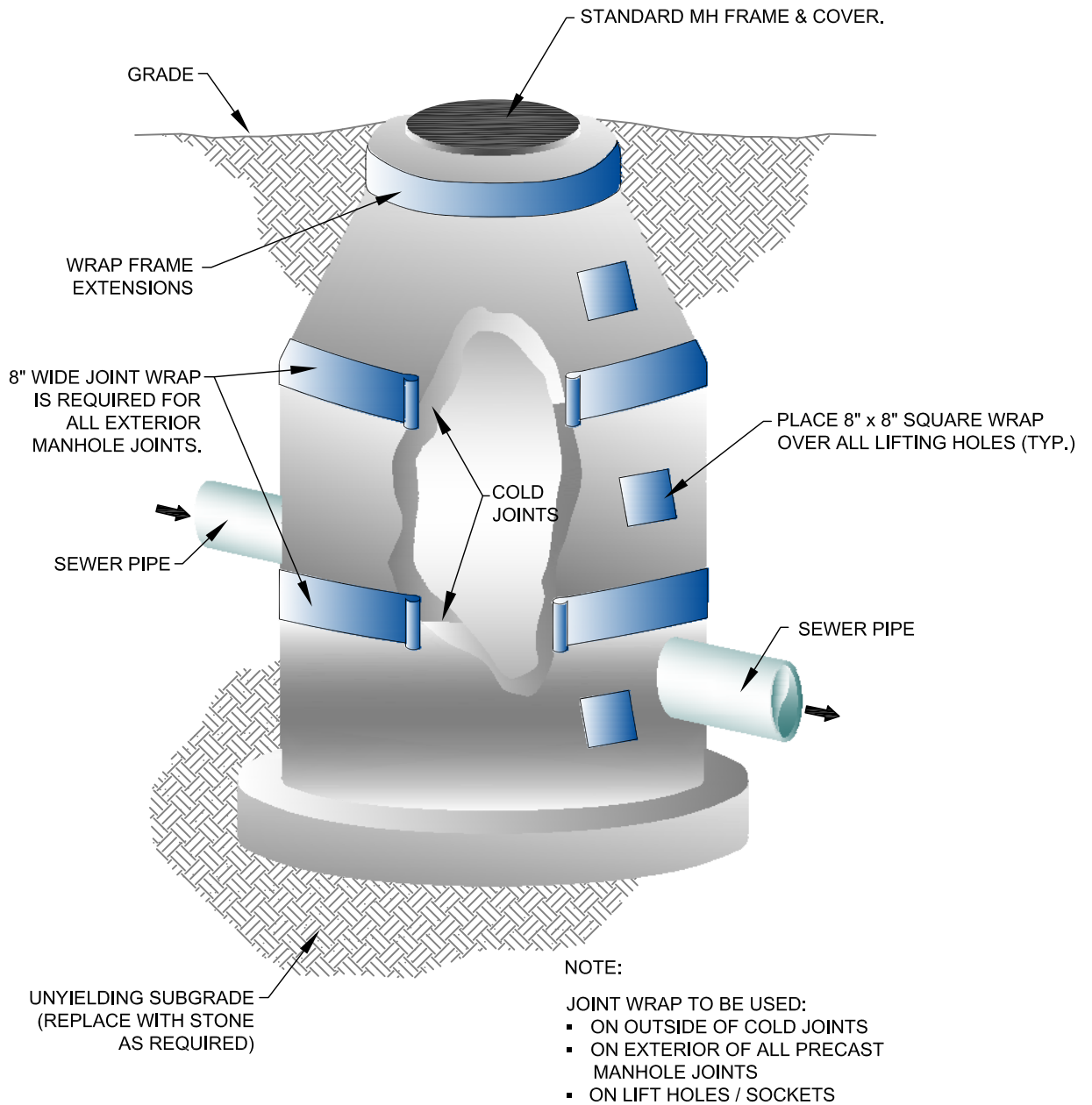

MANHOLE JOINT WRAP



CITY OF BRYANT, AR
 WATER UTILITIES
 210 S.W. 3rd. STREET
 BRYANT, AR
 PHONE: (501) 943-0468

TITLE:	SEWER DETAILS	
DESCRIPTION:	MANHOLE JOINT WRAP	
DRAWN BY:	CHECKED BY:	FILE: S9-Manhole Joint Wrap.dwg

DATE:	APRIL 2015
	REVISED

SHEET:
S9

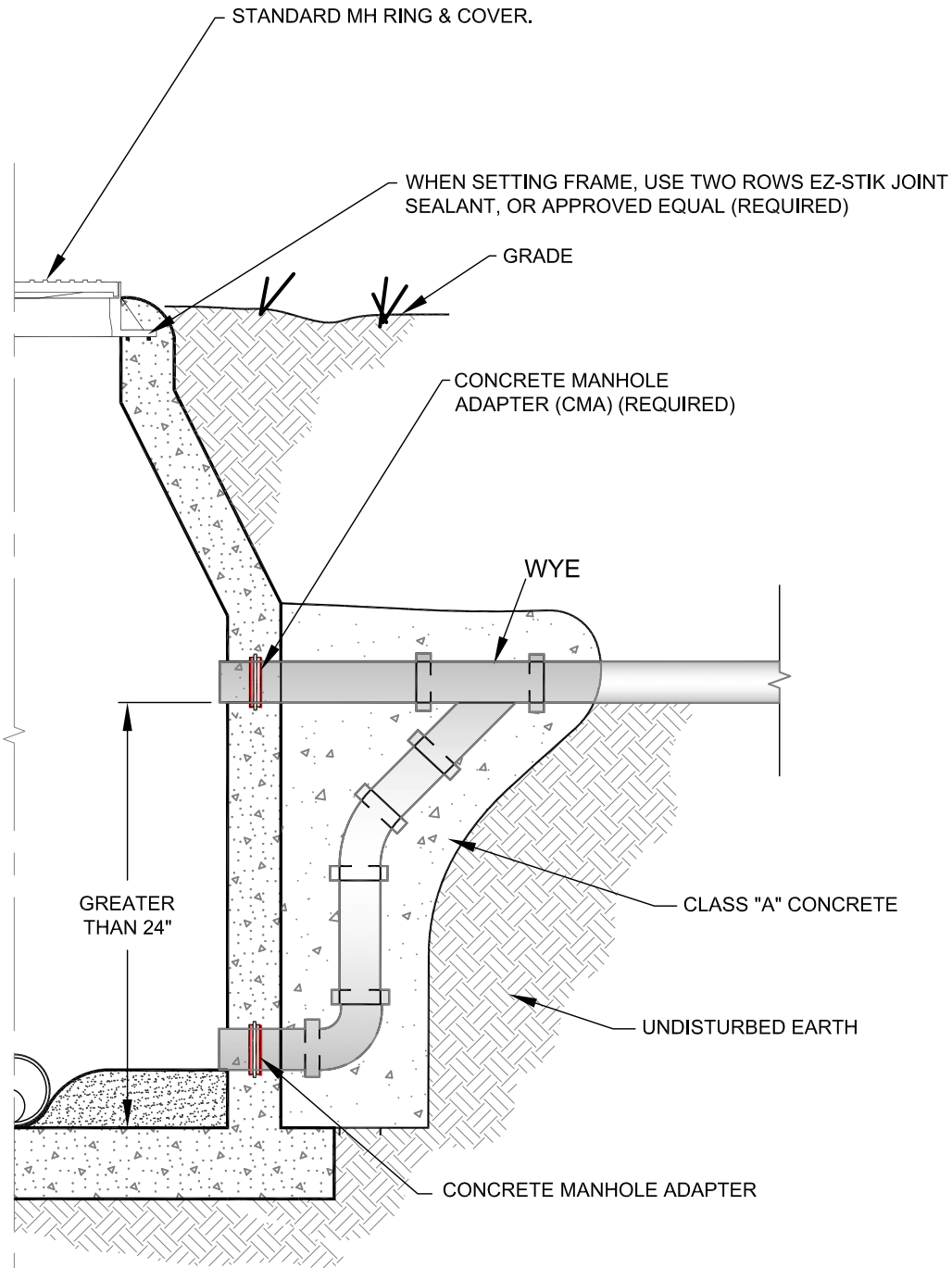

* THE CONNECTIONS TO EXISTING MANHOLES ARE TO BE CORE-DRILLED WITH THE USE OF A WATER-STOP AND NON-SHRINK GROUT.

DROP MANHOLE

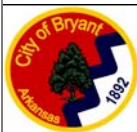

CITY OF BRYANT, AR
 WATER UTILITIES
 210 S.W. 3rd. STREET
 BRYANT, AR
 PHONE: (501) 943-0468

TITLE:	SEWER DETAILS	
DESCRIPTION:	DROP MANHOLE	
DRAWN BY:	CHECKED BY:	FILE: S10-Drop Manhole.dwg

DATE:	APRIL 2015
	REVISED

SHEET:
S10

THE INSTALLATION SHALL BE
DYE TESTED FOR ACCEPTANCE.

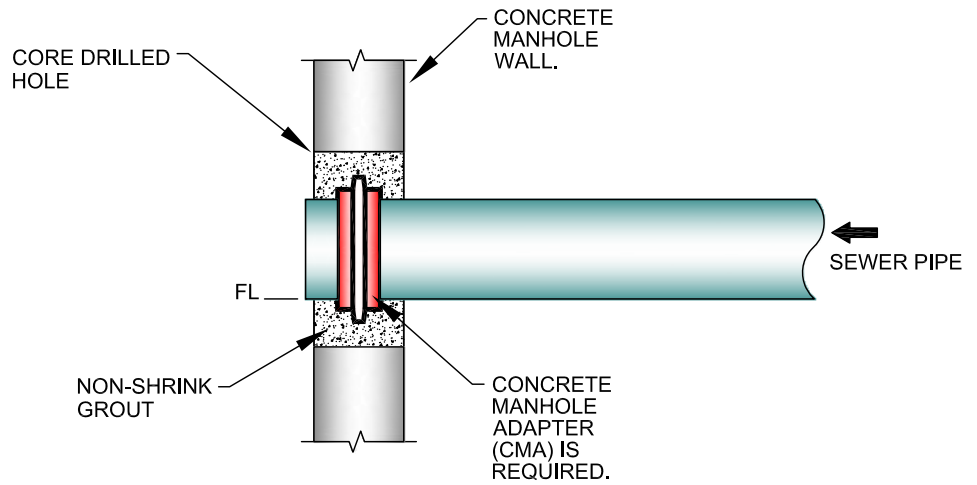
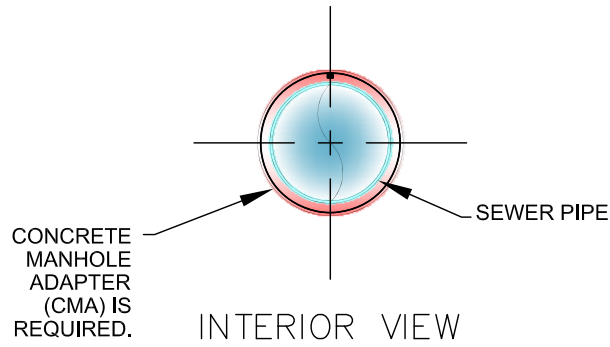

MANHOLE CORING DETAILS



CITY OF BRYANT, AR
 WATER UTILITIES
 210 S.W. 3rd. STREET
 BRYANT, AR
 PHONE: (501) 943-0468

TITLE:	SEWER DETAILS	
DESCRIPTION:	MANHOLE CORING	
DRAWN BY:	CHECKED BY:	FILE: S11-Manhole Coring.dwg

DATE:	APRIL 2015
REVISED	----

SHEET:
S11

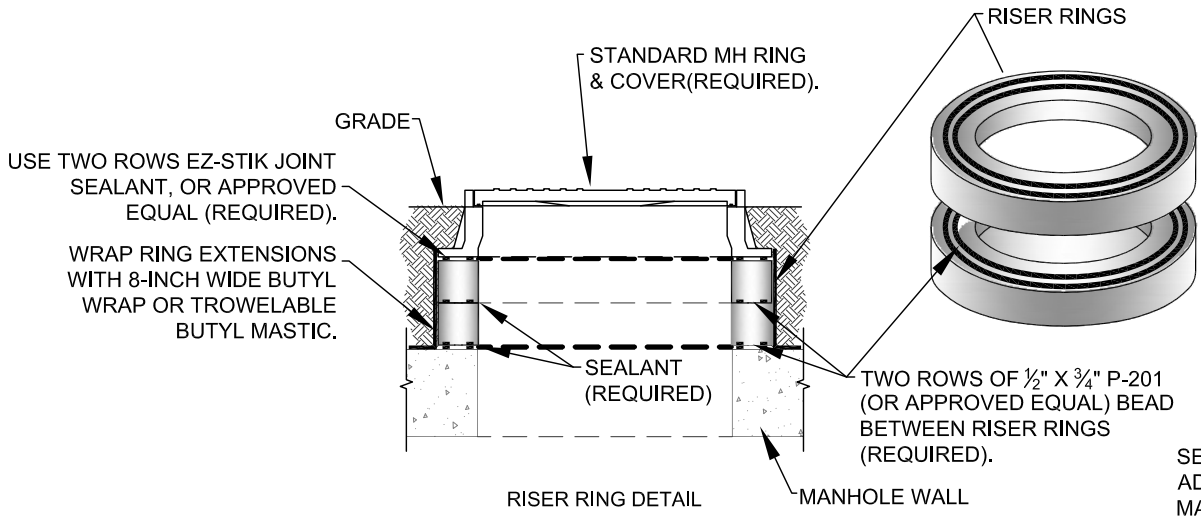
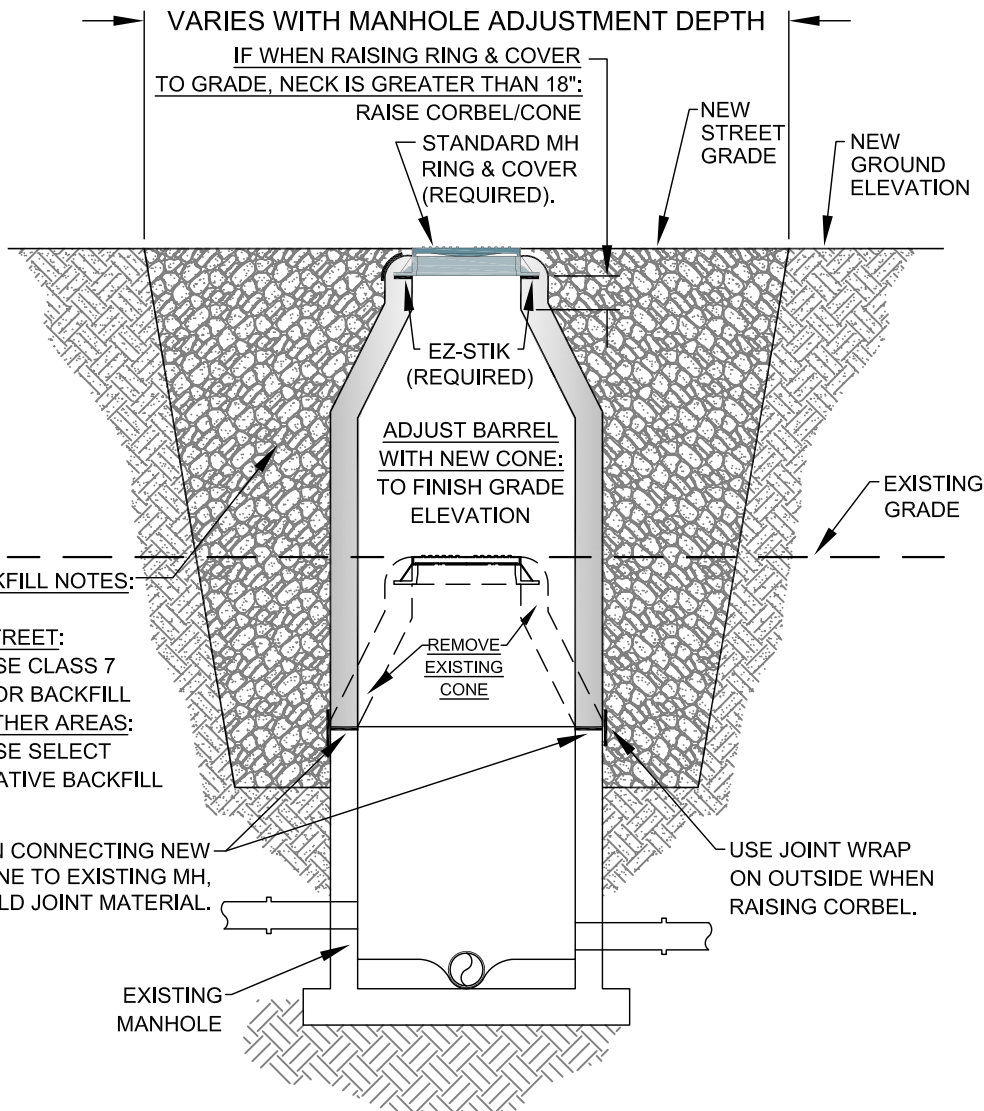

SEALANT SHALL BE ADEKA P-201 or MANUS-BOND 75AM

TYPICAL MANHOLE ADJUST TO GRADE DETAIL



CITY OF BRYANT, AR
 WATER UTILITIES
 210 S.W. 3rd. STREET
 BRYANT, AR
 PHONE: (501) 943-0468

TITLE:	SEWER DETAILS	
DESCRIPTION:	MANHOLE ADJUST TO GRADE	
DRAWN BY:	CHECKED BY:	FILE: S12-Manhole Adjust to Grade.dwg

DATE:	APRIL 2015
	REVISED

SHEET:
S12

REMOVE MH RING & COVER, CONE AND/OR BARREL TO A MIN. OF 2'-0" BELOW EXISTING GRADE ELEVATION.

GRADE

2'-0" MIN.

FILL MANHOLE WITH CLASS I BEDDING MATERIAL

ABANDONED (E) SS

PLUG LINES

CONSTRUCT CONCRETE PLUG FROM INSIDE OF THE EXISTING MANHOLE. FILL BOTTOM OF MANHOLE WITH CONCRETE TO 6" ABOVE THE CROWN OF ALL PIPES. NO EXCAVATION IS REQUIRED.

ABANDONED (E) SS

BACKFILL, REPAVE or RESURFACE
BACKFILL ABANDONMENT IN PAVED AREAS, AND PERFORM PAVEMENT REPAIR AS PER STANDARD SPECIFICATIONS APPROPRIATE DETAIL.

BACKFILL ABANDONMENT IN NONPAVED AREAS WITH SELECT NATIVE MATERIAL, AND RESURFACE WITH APPROPRIATE MATERIALS.

GRADE

GRADE

ABANDONED (E) SS

CLASS 7 BACKFILL 95% MODIFIED PROCTOR (TYP).

ABANDONED (E) SS

EXISTING MANHOLE ABANDONMENT DETAIL



CITY OF BRYANT, AR
WATER UTILITIES
210 S.W. 3rd. STREET
BRYANT, AR
PHONE: (501) 943-0468

TITLE:

SEWER DETAILS

DESCRIPTION:

MANHOLE ABANDONMENT

DATE: APRIL 2015

REVISED

SHEET:

S13

DRAWN BY:

CHECKED BY:

FILE: S13-Manhole Abandonment.dwg

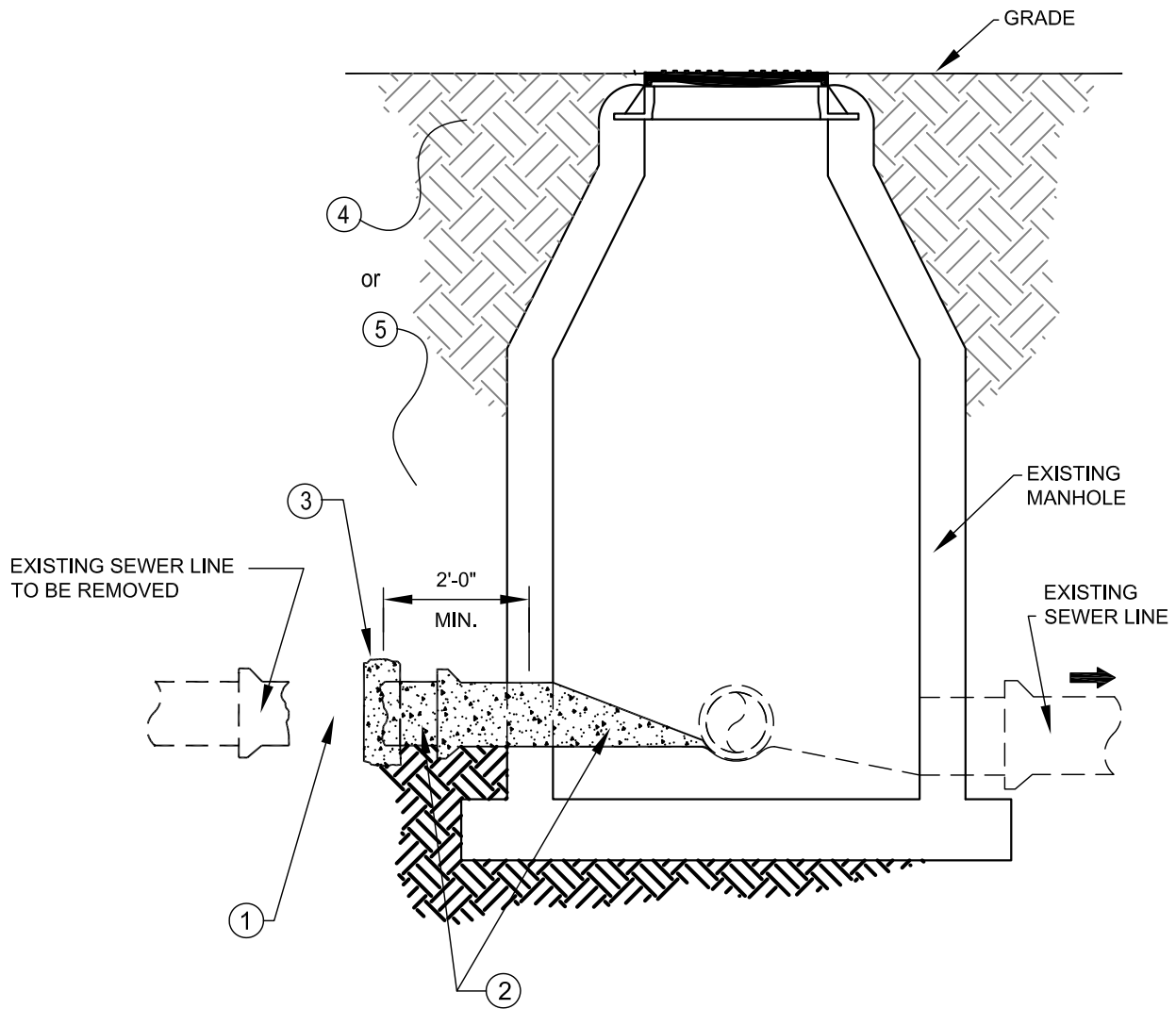

1. EXPOSE EXISTING LINE AND PHYSICALLY DISCONNECT THE LINE SEGMENT TO BE REMOVED. (REQUIRED)
2. FILL REMAINING SEWER PIPE TO BE SEALED WITH CONCRETE AND REINFORCEMENT. (REQUIRED)
3. CONSTRUCT A CONCRETE CAP AROUND PIPE CONNECTED TO EXISTING MANHOLE. (REQUIRED)
4. IF THE MANHOLE IS LOCATED IN A PAVED AREA, BACKFILL THE EXCAVATED AREA AND PERFORM PAVEMENT REPAIR. (REQUIRED)
5. IF THE MANHOLE IS LOCATED IN A NON-PAVED AREA, BACKFILL THE EXCAVATED AREA WITH SELECT NATIVE MATERIAL, AND RESURFACE WITH THE APPROPRIATE MATERIALS. (REQUIRED)

SEWER LINE DISCONNECT & SEAL DETAIL



CITY OF BRYANT, AR
 WATER UTILITIES
 210 S.W. 3rd. STREET
 BRYANT, AR
 PHONE: (501) 943-0468

TITLE: SEWER DETAILS		DATE: APRIL 2015	SHEET: S14
DESCRIPTION: SEWER LINE DISCONNECT AND SEAL		REVISED	
DRAWN BY:		----	
CHECKED BY:		----	
FILE: S14-Sewer Line Disconnect and Seal.dwg		----	

NOTES:

1. MODIFIED RISER LATERAL SHALL BE USED WHEN DEPTH OF COVER EXCEEDS 7'-0"
2. PLACE CLASS "A" CONCRETE UNDER EACH WYE BRANCH TO PREVENT CRACKING OR TWISTING UNDER EARTH LOADS.
3. SERVICE LATERAL STUBS SHALL TERMINATE AT LEAST 2 FEET INSIDE THE PROPERTY LINE BUT IN NO CASE SHALL THE SERVICE LATERAL STUB TERMINATE AT A DISTANCE LESS THAN 8 FEET FROM THE SANITARY SEWER MAIN.
4. BURY A 1/2" x 4' STEEL TEE FENCE POST AT END OF SERVICE LATERAL STUB AND BACKFILL TO FINISHED GRADE OF PROPERTY.
5. 4" DUCTILE IRON PIPE, LINED FOR SANITARY SEWER AND 4" DUCTILE IRON M.J. FITTINGS, LINED FOR SANITARY SEWER, SHALL BE INSTALLED FOR SERVICES BURIED AT DEPTHS OF 14 FEET AND GREATER.

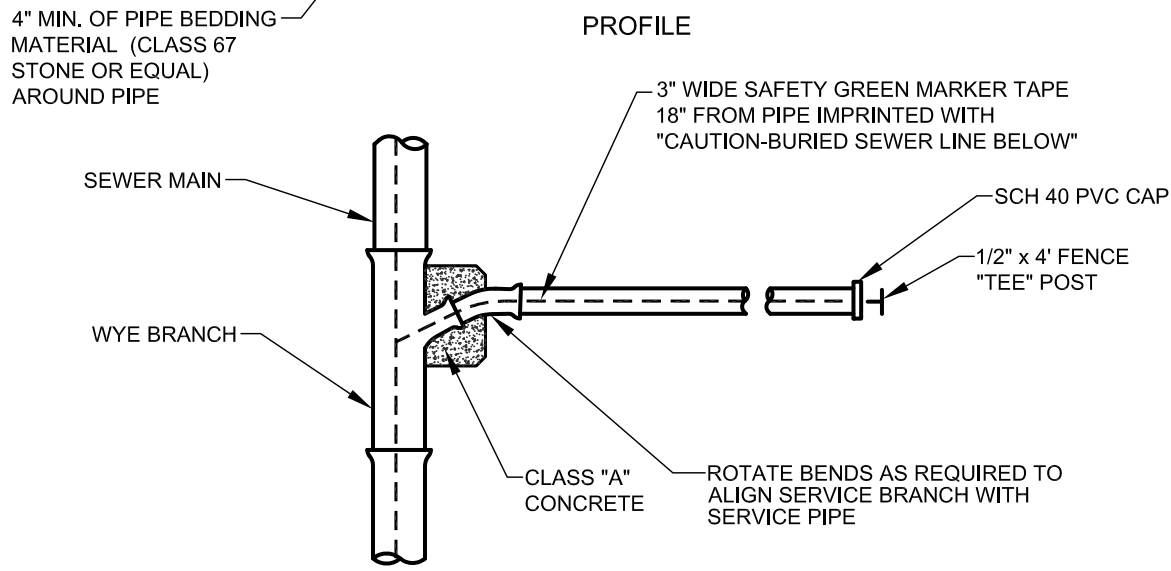
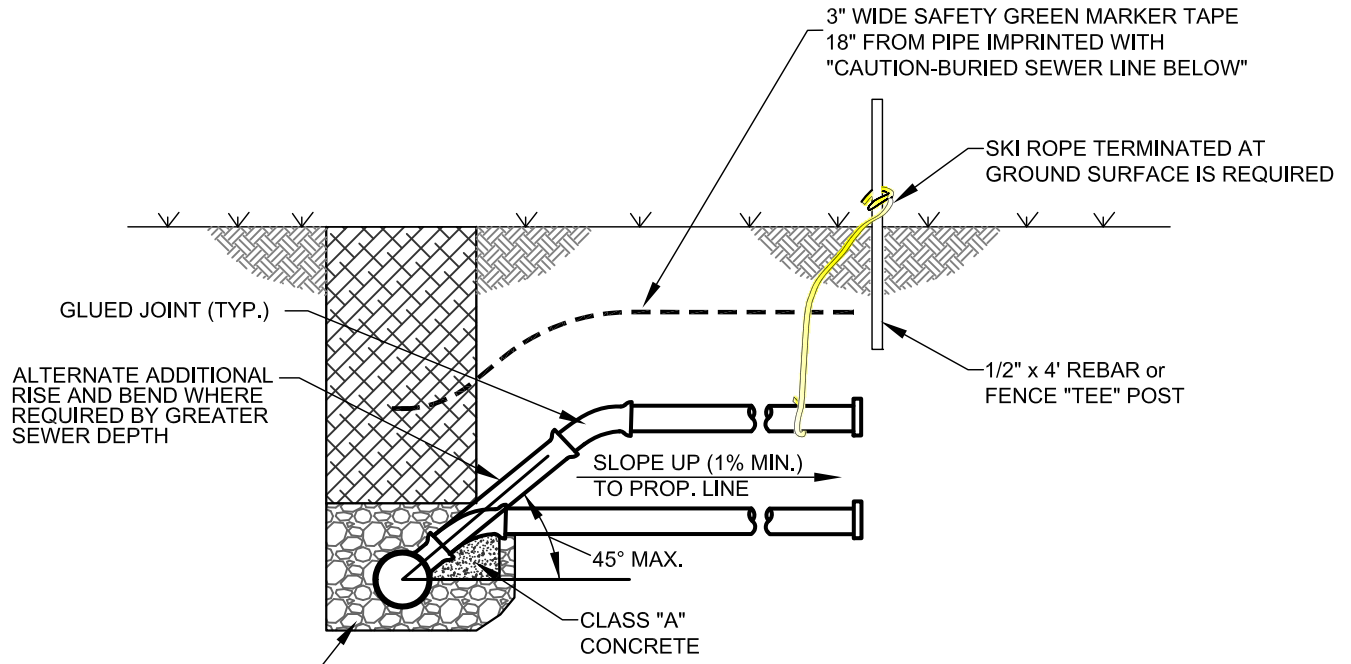

SEWER SERVICE LATERAL



CITY OF BRYANT, AR
 WATER UTILITIES
 210 S.W. 3rd. STREET
 BRYANT, AR
 PHONE: (501) 943-0468

TITLE:	SEWER DETAILS	
DESCRIPTION:	SEWER SERVICE LATERAL	
DRAWN BY:	CHECKED BY:	FILE: S15-Sewer Service Lateral.dwg

DATE:	APRIL 2015
	REVISED

SHEET:
S15

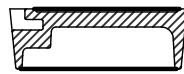

COVER SECTION



COVER TOP VIEW

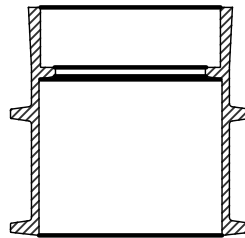

VALVE BOX SECTION

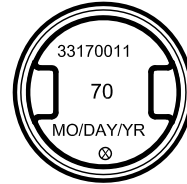

COVER BACK VIEW

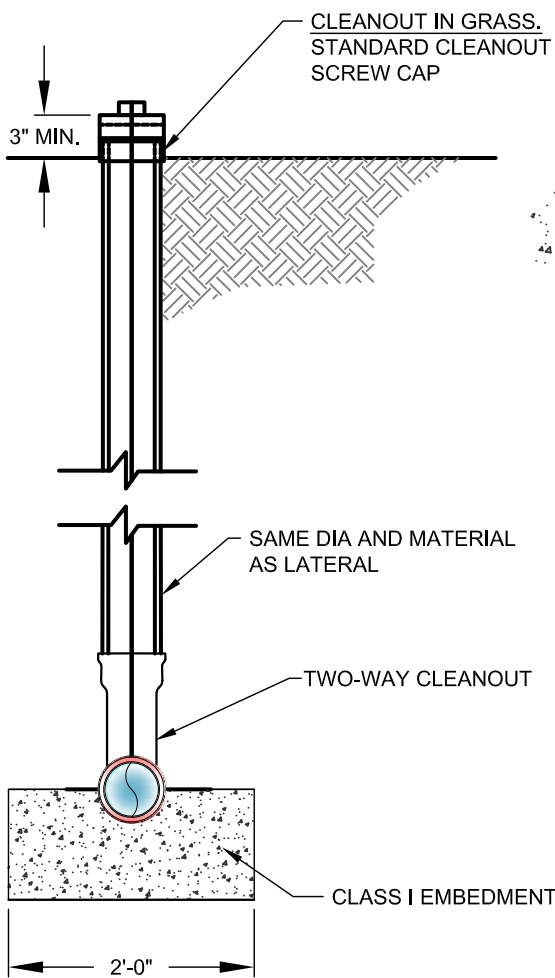

END VIEW

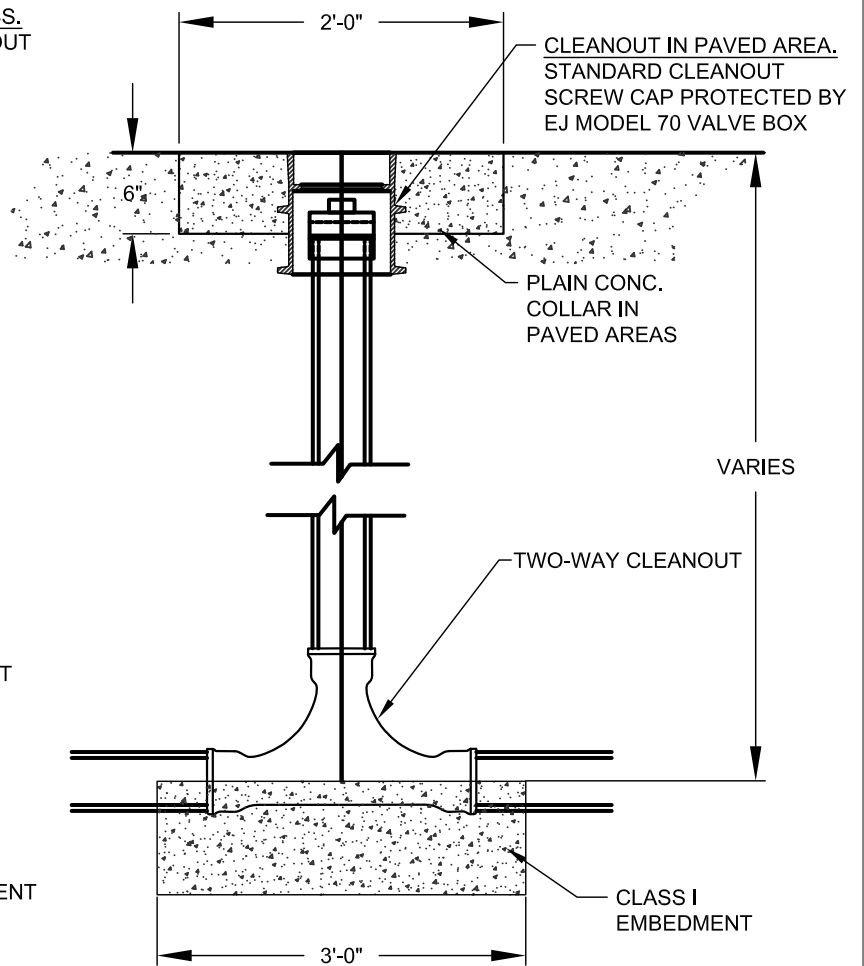

SIDE VIEW

TYPICAL CLEANOUT



CITY OF BRYANT, AR
 WATER UTILITIES
 210 S.W. 3rd. STREET
 BRYANT, AR
 PHONE: (501) 943-0468

TITLE:	SEWER DETAILS	
DESCRIPTION:	SEWER SERVICE CLEANOUT	
DRAWN BY:	CHECKED BY:	FILE: S16-Sewer Service Cleanout.dwg

DATE:	APRIL 2015
	REVISED

SHEET:
S16

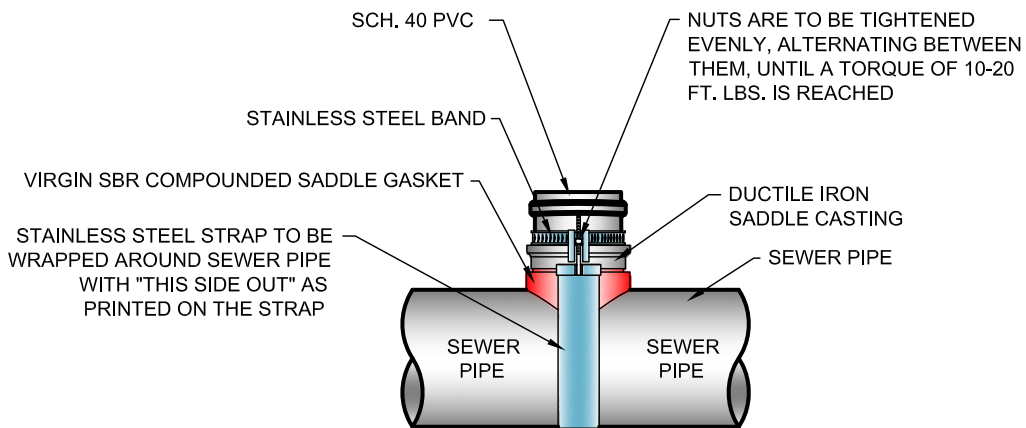
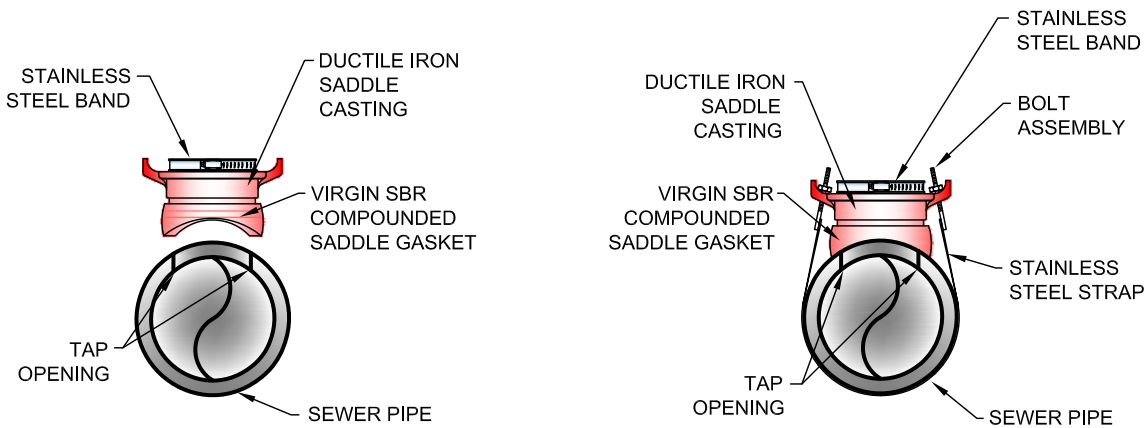

SEWER SERVICE SADDLE



CITY OF BRYANT, AR
 WATER UTILITIES
 210 S.W. 3rd. STREET
 BRYANT, AR
 PHONE: (501) 943-0468

TITLE:	SEWER DETAILS	
DESCRIPTION:	SEWER SERVICE SADDLE	
DRAWN BY:	CHECKED BY:	FILE: S17-Sewer Service Saddle.dwg

DATE:	APRIL 2015
	REVISED

SHEET:
S17

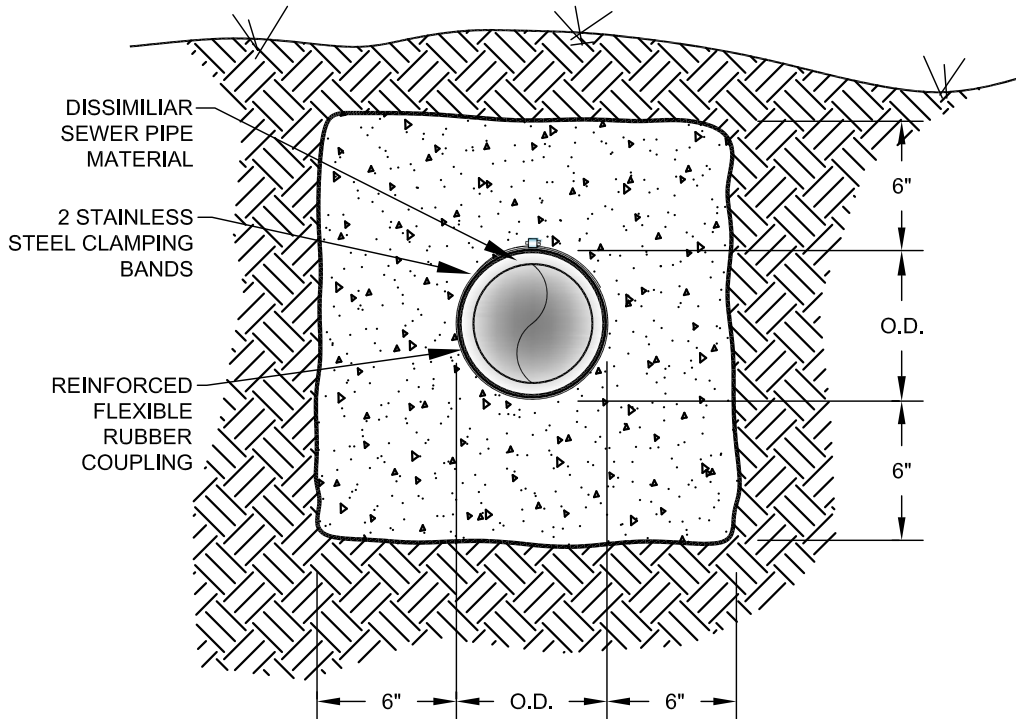
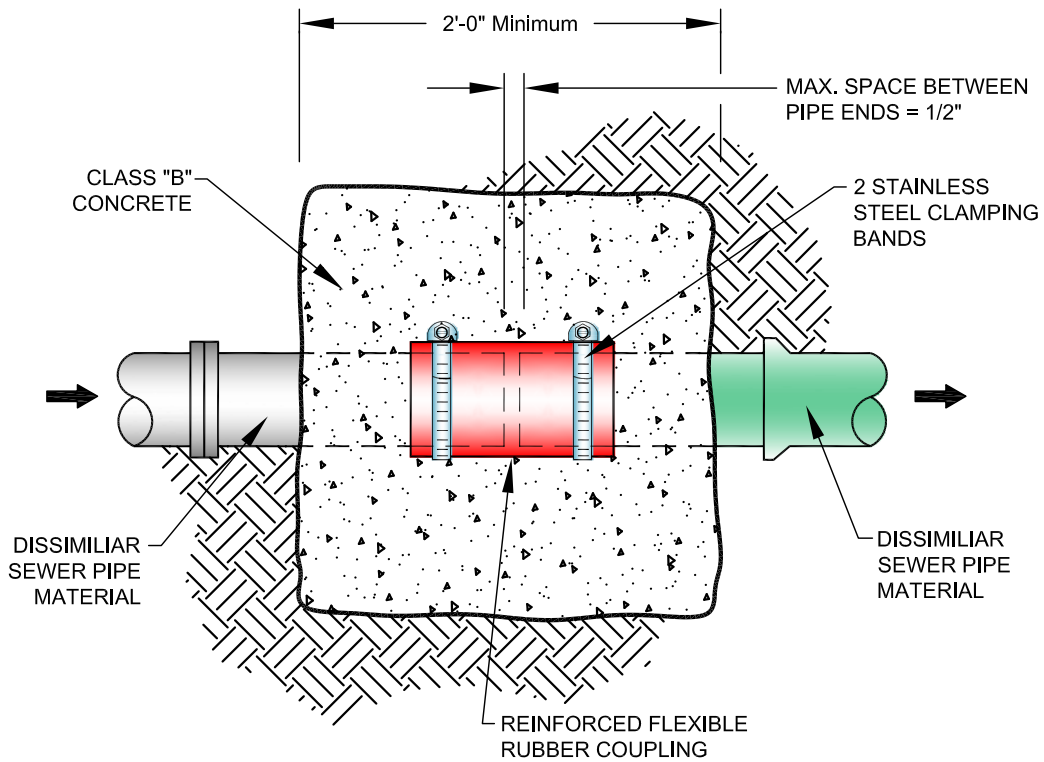

REINFORCE FLEXIBLE COUPLING

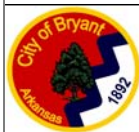

CITY OF BRYANT, AR
 WATER UTILITIES
 210 S.W. 3rd. STREET
 BRYANT, AR
 PHONE: (501) 943-0468

TITLE:	SEWER DETAILS	
DESCRIPTION:	REINFORCED FLEXIBLE COUPLING	
DRAWN BY:	CHECKED BY:	FILE: S18-Reinforced Flexible Coupling.dwg

DATE:	APRIL 2015
	REVISED

SHEET:
S18

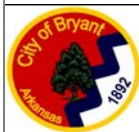
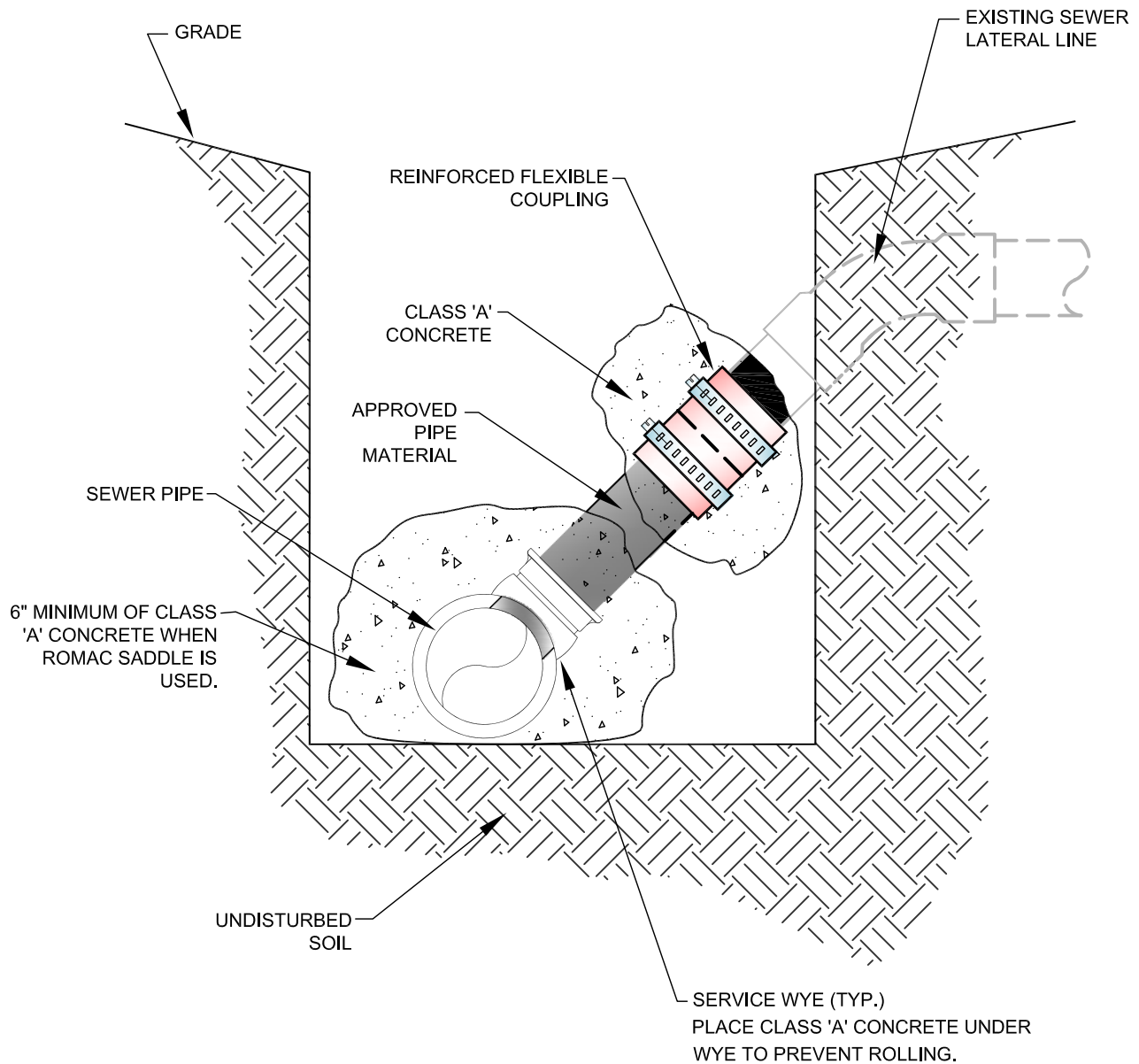

CITY OF BRYANT, AR
 WATER UTILITIES
 210 S.W. 3rd. STREET
 BRYANT, AR
 PHONE: (501) 943-0468

TITLE: SEWER DETAILS		DATE: APRIL 2015	SHEET: S19
DESCRIPTION: CONNECT TO EXISTING SEWER SERVICE		REVISED	
DRAWN BY:	CHECKED BY:	----	

FILE: S19-Connect to Existing Sewer Service.dwg		----	

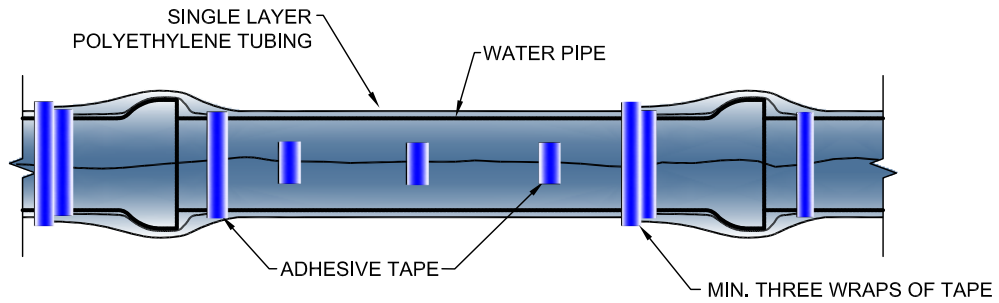

METHOD 'A'

METHOD 'A' USES ONE LENGTH OF POLYETHYLENE TUBE, OVERLAPPED AT THE JOINTS A MINIMUM OF 2 FEET.

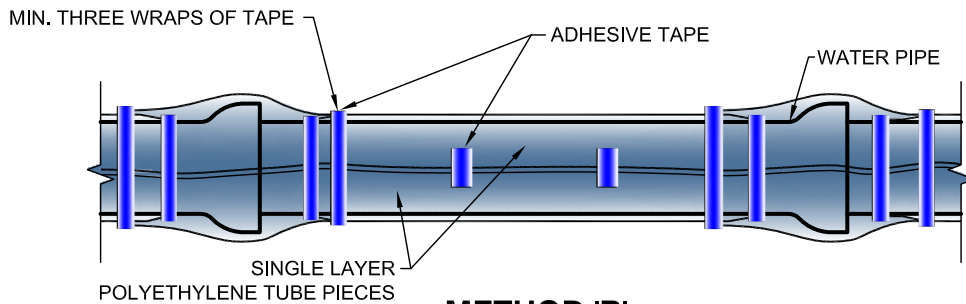

METHOD 'B'

METHOD 'B' USES SEPARATE PIECES OF POLYETHYLENE TUBE FOR THE BARREL OF THE PIPE AND THE JOINTS. SHORT PIECES SHALL BE APPROXIMATELY 6' LONG AND OVERLAP BARREL SECTION BY A MINIMUM OF 2 FEET.

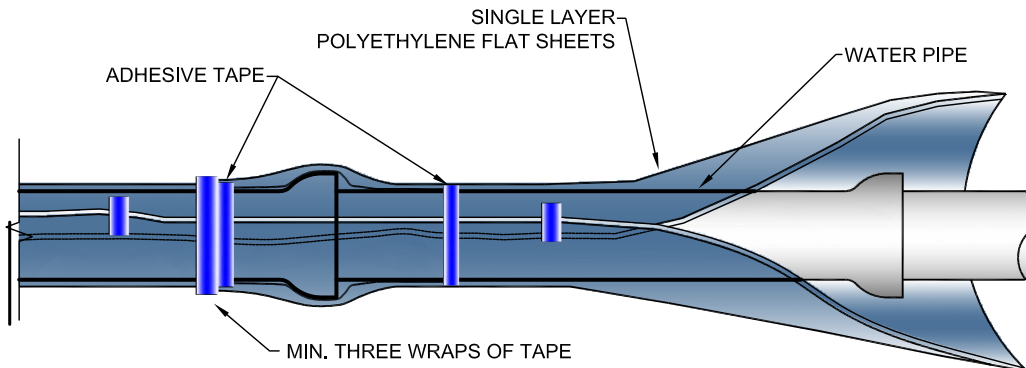

METHOD 'C'

METHOD 'C' - USED FOR PIPE-SHAPED AND ODD-SHAPED APPURTENANCES SUCH AS BENDS, REDUCERS, OFFSETS, VALVES, TEES, ETC.

ALL DUCTILE IRON PIPE AND FITTINGS SHALL BE POLY WRAPPED.

THE ANSI/AWWA C105/A21.5 STANDARD OUTLINES THREE METHODS OF INSTALLING POLYETHYLENE ENCASEMENT/ SLEEVING.



CITY OF BRYANT, AR
 WATER UTILITIES
 210 S.W. 3rd. STREET
 BRYANT, AR
 PHONE: (501) 943-0468

TITLE:	SEWER DETAILS	
DESCRIPTION:	POLYETHYLENE PROTECTION MATERIAL	
DRAWN BY:	CHECKED BY:	FILE: S20-Poly Wrap.dwg

DATE:	APRIL 2015
	REVISED

SHEET:
S20

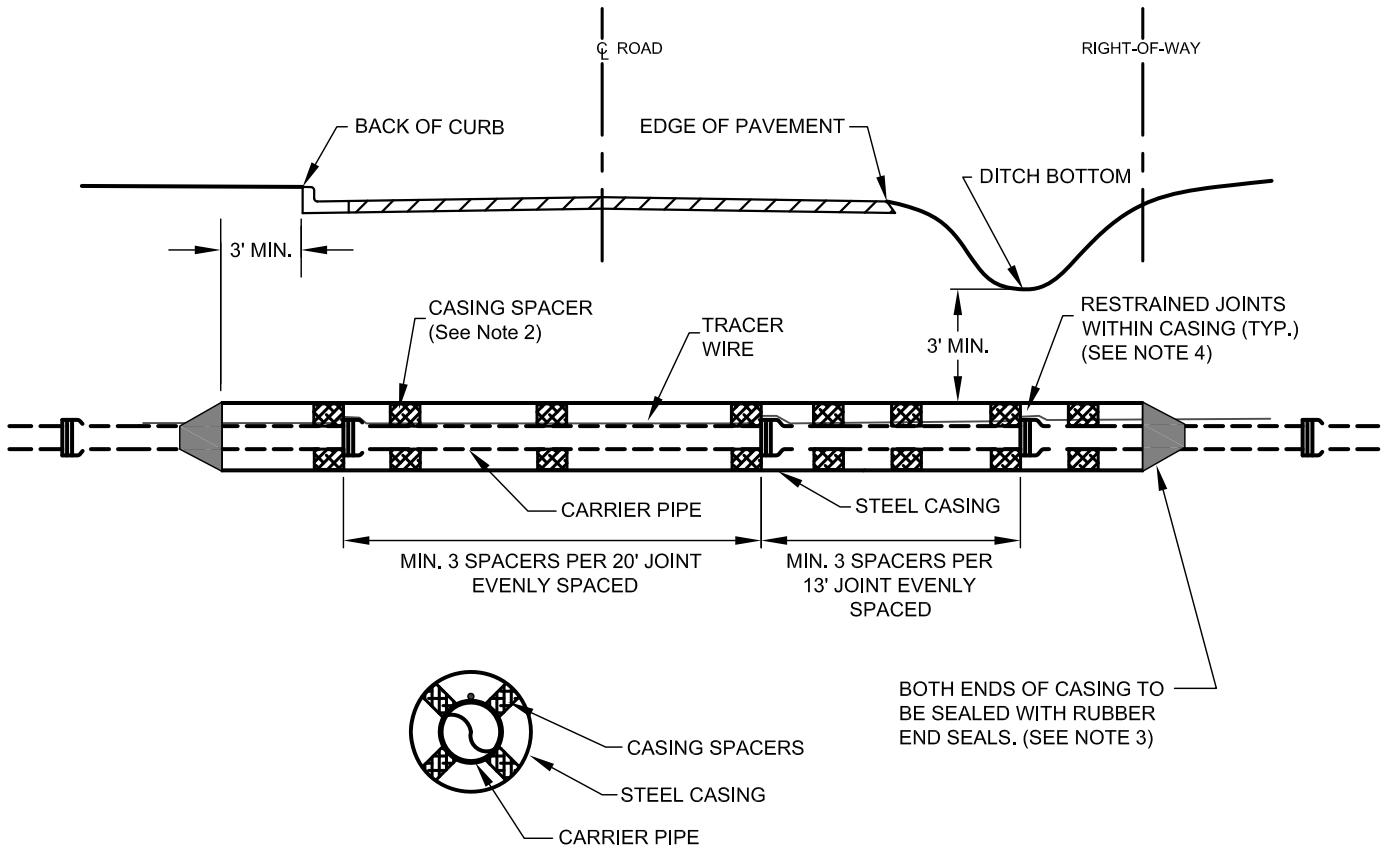

NOTES:

1. STEEL CASING SHALL BE CONSTRUCTED OF SPIRAL OR STRAIGHT WELDED STEEL WITH A MINIMUM DIAMETER AND THICKNESS AS SHOWN BELOW (SEE TABLE).
2. PROVIDE CASING SPACERS BY CASCADE MODEL CCS AS MANUFACTURED BY CASCADE WATERWORKS MFG. CO., OR APPROVED EQUAL, MINIMUM 12-INCHES WIDE..
3. PROVIDE END SEALS BY CASCADE MODEL CCES AS MANUFACTURED BY CASCADE WATERWORKS MFG. CO., OR APPROVED EQUAL.
4. ONE CASING SPACER SHALL BE PLACED AT THE INSERTION STOP LINE TO RESIST OVER INSERTION.
5. ALL FORCE MAINS SHALL BE FULLY RESTRAINED WHERE ENCASEMENTS ARE GREATER THAN 25 FEET IN LENGTH, SELF-RESTRAINING GASKETS OR BELL RESTRAINTS SHALL BE USED FOR ALL JOINTS INSIDE THE ENCASEMENT PIPE AND FOR THE FIRST JOINT IN EACH DIRECTION OUTSIDE THE ENCASEMENT PIPE.
6. DIRECT BURY STEEL ENCASEMENT SHALL BE POLY WRAPPED.

CARRIER AND CASING SIZES							
CARRIER (ID)	2"	3"	4"	6"	8"	10"	12"
CASING (ID)	5"	6"	8"	12"	16"	20"	24"
CASING WALL THICKNESS	0.250	0.250	0.250	0.250	0.250	0.250	0.375
CARRIER (ID)	14" - 16"	18" - 20"	24"	30"	36"	42"	48"
CASING (ID)	30"	36"	42"	48"	54"	60"	72"
CASING WALL THICKNESS	0.375	0.500	0.625	0.625	0.625	0.625	0.750

STEEL ENCASEMENT



CITY OF BRYANT, AR
 WATER UTILITIES
 210 S.W. 3rd. STREET
 BRYANT, AR
 PHONE: (501) 943-0468

TITLE:	SEWER DETAILS		
DESCRIPTION:	STEEL ENCASEMENT		
DRAWN BY:	CHECKED BY:	FILE: S21-Steel Encasement.dwg	

DATE:	APRIL 2015
	REVISED

SHEET:
S21

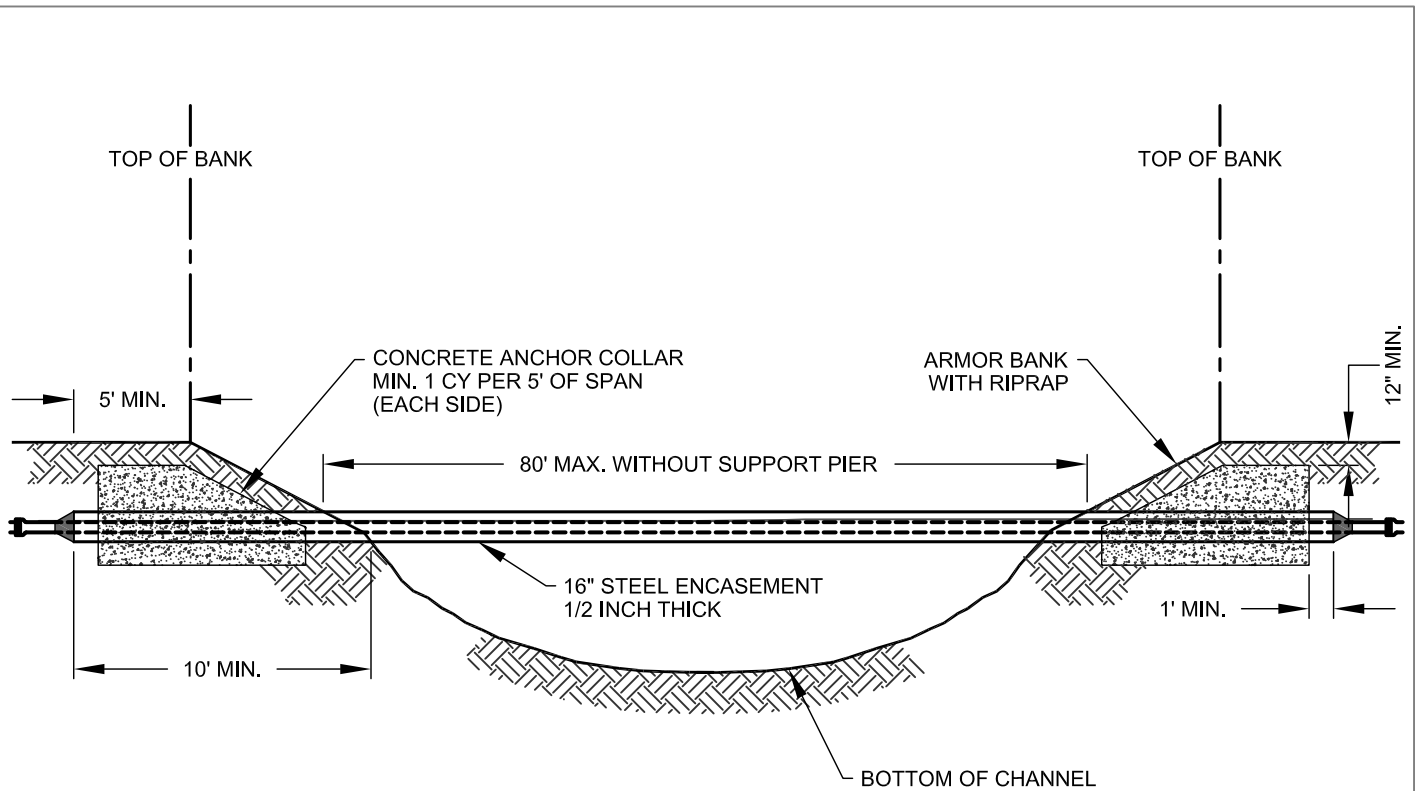

NOTES:

1. DETAIL SHOWN IS FOR 16" ENCASMENT WITH 8" SEWER PIPE AT 0.50% GRADE. OTHER SIZES WILL REQUIRE A DETAILED DESIGN WITH A MAXIMUM DEFLECTION OF L/360.
2. REFER TO STEEL ENCASMENT DETAIL FOR ADDITIONAL INSTALLATION REQUIREMENTS.
3. STEEL CASING SHALL BE CONSTRUCTED OF SPIRAL OR STRAIGHT WELDED STEEL.
4. PROVIDE CASING SPACERS BY CASCADE MODEL CCS AS MANUFACTURED BY CASCADE WATERWORKS MFG. CO., OR APPROVED EQUAL, MINIMUM 12-INCHES WIDE.
5. PROVIDE END SEALS BY CASCADE MODEL CCES AS MANUFACTURED BY CASCADE WATERWORKS MFG. CO., OR APPROVED EQUAL.
6. ONE CASING SPACER SHALL BE PLACED AT THE INSERTION STOP LINE TO RESIST OVER INSERTION.
7. ALL FORCE MAINS SHALL BE FULLY RESTRAINED WHERE ENCASMENTS ARE GREATER THAN 25 FEET IN LENGTH, SELF-RESTRAINING GASKETS OR BELL RESTRAINTS SHALL BE USED FOR ALL JOINTS INSIDE THE ENCASMENT PIPE AND FOR THE FIRST JOINT IN EACH DIRECTION OUTSIDE THE ENCASMENT PIPE.
8. BELL RESTRAINTS FOR PVC SHALL BE SERIES 1900 RESTRAINT HARNESS AND BELL RESTRAINTS FOR DIP SHALL BE SERIES 1700 RESTRAINT HARNESS BY EBAA IRON INC., OR APPROVED EQUAL.
9. DIRECT BURY STEEL ENCASMENT SHALL BE POLY WRAPPED.



CITY OF BRYANT, AR
 WATER UTILITIES
 210 S.W. 3rd. STREET
 BRYANT, AR
 PHONE: (501) 943-0468

TITLE:	SEWER DETAILS	
DESCRIPTION:	STEEL ENCASMENT AERIAL CROSSING	
DRAWN BY:	CHECKED BY:	FILE: S22-Steel Encasement-Aerial Crossing.dwg

DATE:	APRIL 2015
	REVISED

SHEET:
S22

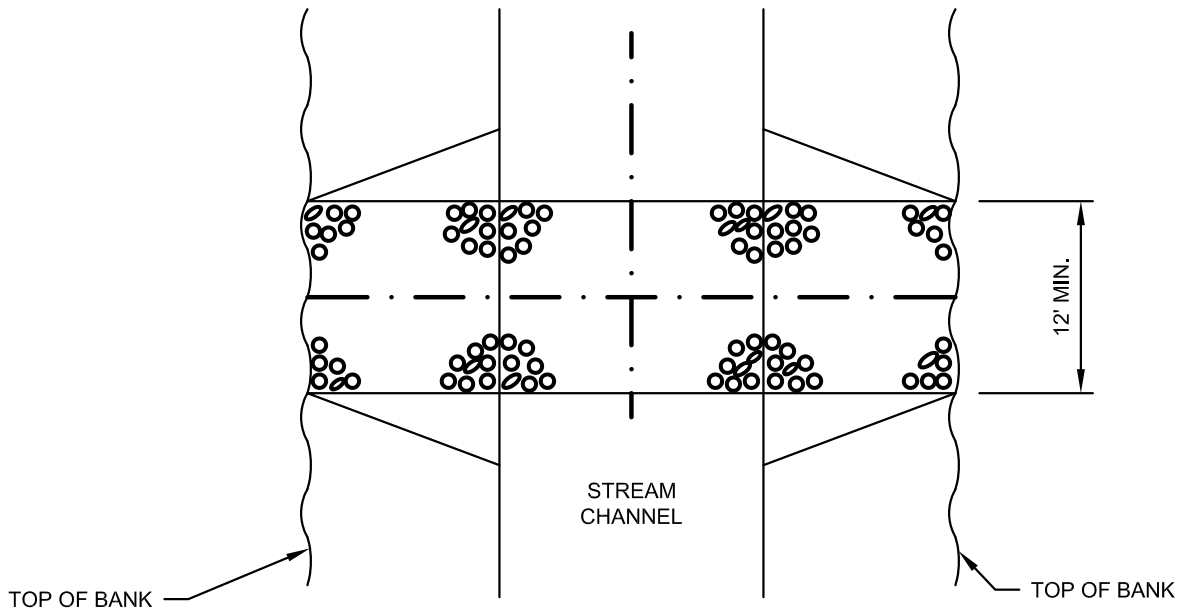

PLAN VIEW

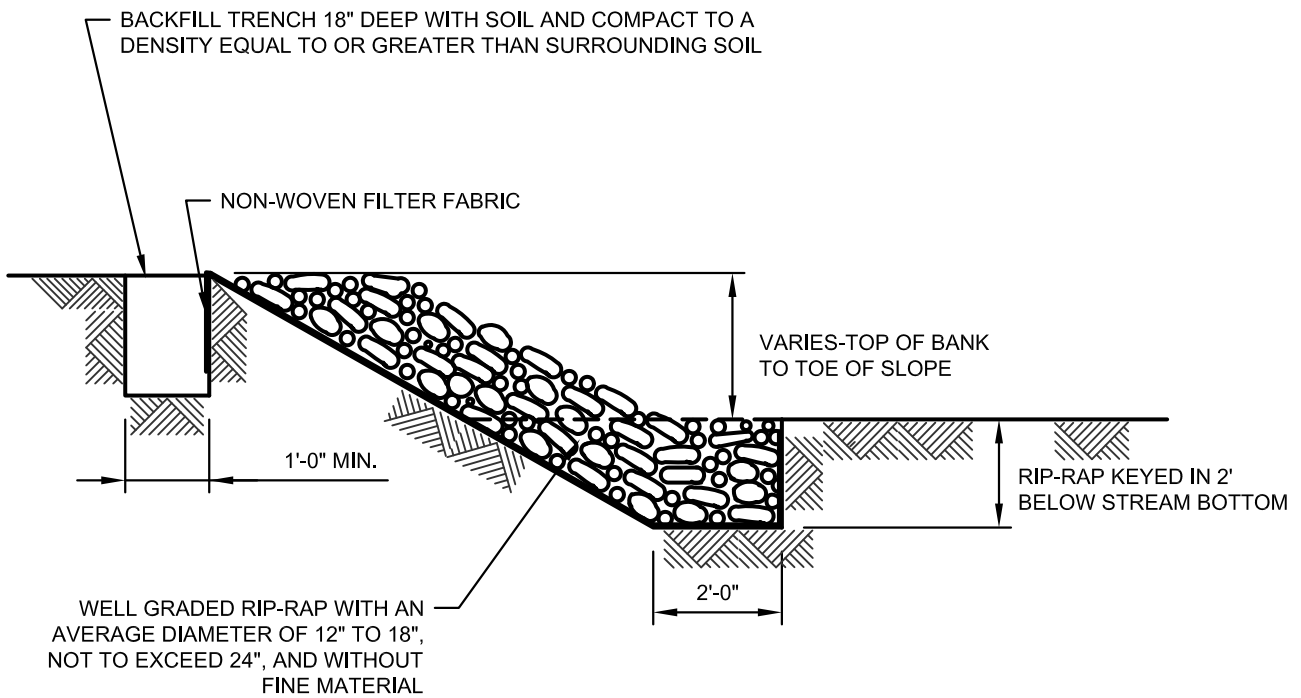

SECTION

NOTE:

1. ALL DISTURBED STREAMBANKS SHALL BE STABILIZED AS SHOWN AND RESTORED TO PRE-CONSTRUCTION GRADES.
2. MINIMUM WIDTH OF RESTORATION SHALL BE 12 FEET.

BANK STABILIZATION



CITY OF BRYANT, AR
 WATER UTILITIES
 210 S.W. 3rd. STREET
 BRYANT, AR
 PHONE: (501) 943-0468

TITLE:	SEWER DETAILS	
DESCRIPTION:	BANK STABILIZATION	
DRAWN BY:	CHECKED BY:	FILE: S23-Bank Stabilization.dwg

DATE:	APRIL 2015
REVISED:	----

SHEET:
S23

NOTES:

1. SEWER LINE MARKERS SHALL BE TRI-VIEW MARKING SYSTEM BY RHINO MARKING AND PROTECTION SYSTEMS OR CARSONITE INTERNATIONAL DUAL-SIDED UTILITY MARKER (CIB-380).
2. THE UPPERMOST PORTION OF THE CARSONITE MARKER SHALL BE MADE OF VISIBILITY ENHANCER (CVE-360).
3. TRI-VIEW MARKERS DO NOT REQUIRE VISIBILITY ENHANCERS.
4. AN ADDITIONAL WHITE 1" WIDE REFLECTIVE TAPE (3M OR EQUAL) SHALL BE PLACED AROUND THE FULL CIRCUMFERENCE OF THE TOP OF THE MARKER.

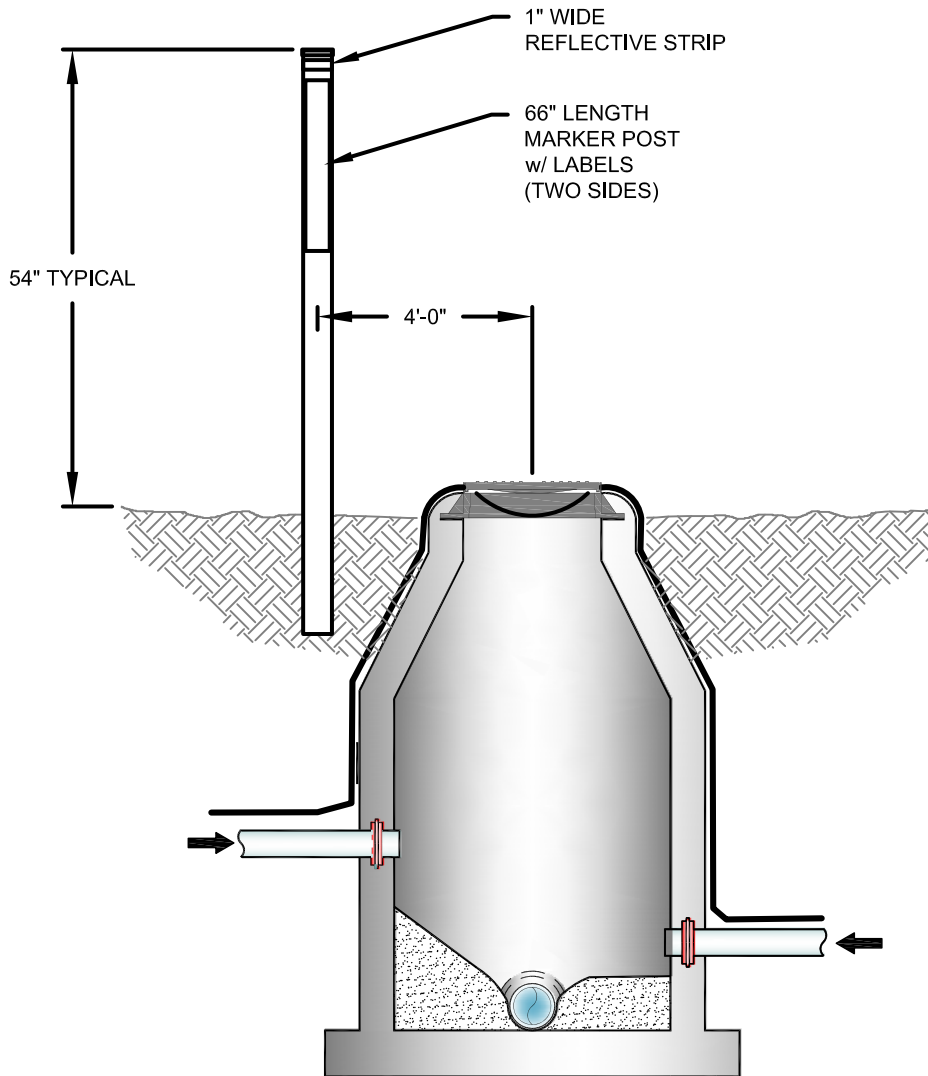

SEWER MARKER



CITY OF BRYANT, AR
 WATER UTILITIES
 210 S.W. 3rd. STREET
 BRYANT, AR
 PHONE: (501) 943-0468

TITLE:	SEWER DETAILS	
DESCRIPTION:	SEWER MARKER	
DRAWN BY:	CHECKED BY:	FILE: S24-Sewer Marker.dwg

DATE:	APRIL 2015
REVISED:	----

SHEET:
S24

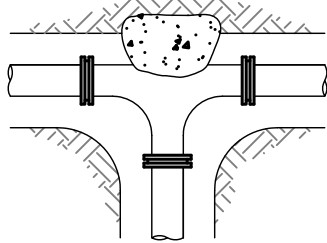

TEE

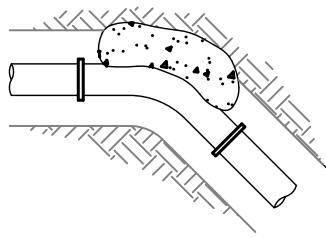

11 1/4°, 22 1/2°
AND/OR 45° BEND

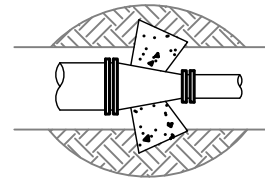

REDUCER

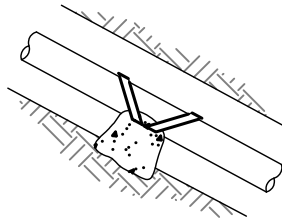

HORIZONTAL RUN

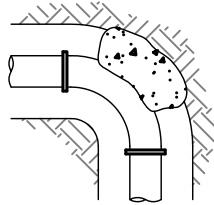

90° BEND *

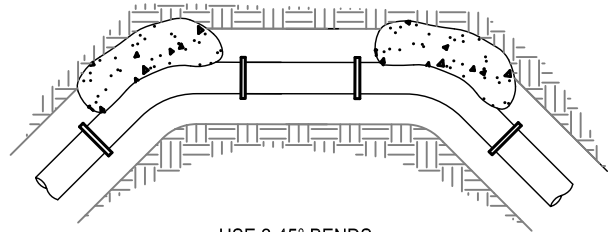

USE 2-45° BENDS
IN PLACE OF 90° BEND

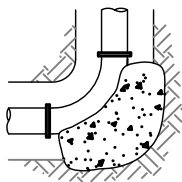

VERTICAL RUN

SEE SHEET W18 FOR
VERTICAL TIE-DOWN BLOCKING

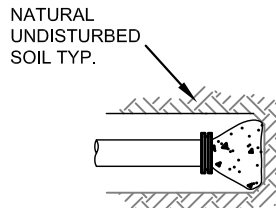

END PLUG, CAP
OR BLIND FLANGE

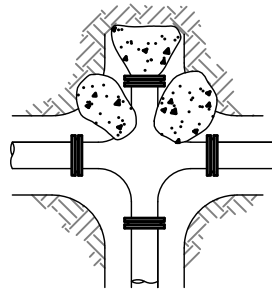

CROSS WITH PLUG

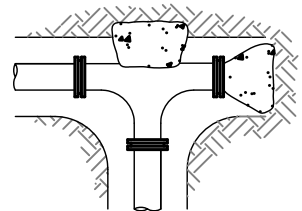

TEE WITH PLUG

THRUST BLOCK SCHEDULE												
(2000 PSF SOIL, 200 PSI WATER PRESSURE, 100 PSI WATER HAMMER)												
BEARING AREA OF THRUST BLOCKS IN SQ. FT. (HORIZONTAL BENDS)						VOLUME OF THRUST BLOCK IN CU. FEET (VERTICAL BENDS)						
FITTING SIZE	PLUG TEE OR CAP	BEND ANGLE				FITTING SIZE	BEND ANGLE				ROD DIAM.	EMBEDMENT
		90° *	45°	22 1/2°	11 1/4°		90° *	45°	22 1/2°	11 1/4°		
2, 3, & 4	1.9	2.7	1.4	0.7	0.4	2, 3, & 4	35.5	19.2	9.8	4.9	.50"	30"
6	5.6	7.9	4.3	2.2	1.1	6	105.8	57.2	29.2	14.7	.75"	30"
8	9.6	13.6	7.4	3.8	1.9	8	181.9	98.5	50.2	25.2	.75"	30"
12	20.5	29.0	15.7	8.0	4.0	12	387.1	209.5	106.8	53.7	1.0"	30"
16	35.7	50.4	27.3	13.9	7.0	16	672.6	364.0	185.6	93.2	1.0"	36"
18	44.8	63.4	34.3	17.5	18.8	18	844.7	457.2	233.1	117.1	1.0"	36"
24	78.4	110.9	60.0	30.6	15.4	24	1478.7	800.3	408.0	205.0	1.5"	36"

* 90 DEGREE BENDS SHALL ONLY BE USED ON A BY-EXCEPTION BASIS, AND MUST EACH BE SPECIFICALLY APPROVED BY CITY.

THRUST BLOCK NOTES:

1. CONCRETE FOR THRUST BLOCKS - CLASS A CONCRETE SHALL DEVELOP NOT LESS THAN 3000 P.S.I. COMPRESSIVE STRENGTH AT 28 DAYS AND BE PLACED AGAINST UNDISTURBED SOIL.
2. ALL BENDS, BOTH HORIZONTAL AND VERTICAL, SHALL BE BACKED WITH CONCRETE. VERTICAL BENDS SHALL BE PLACED ON CONCRETE PADS WHERE BENDS TURN UP, OR LOADED WHERE BENDS TURN DOWN.
3. WRAP PIPE JOINTS IN 8 MIL "POLYETHYLENE" BEFORE PLACING CONCRETE.
4. BEARING AREA SHOWN IN TABLE, IS BASED UPON A 2000 LB/SF. SOIL BEARING, AND UPON A PIPELINE PRESSURE OF 200 psi. PLUS 100 psi. WATER HAMMER. AREAS SHOWN SHALL BE ADJUSTED, SHOULD FIELD CONDITIONS VARY.
5. MJ RESTRAINTS ARE REQUIRED FOR ALL FITTINGS.
6. USE LONG-RADIUS FITTINGS WHEREVER POSSIBLE.
7. ALL BOLTS FOR FITTINGS SHALL BE 316 STAINLESS STEEL.
8. ALL DUCTILE IRON FITTINGS SHALL BE FUSION-BONDED EPOXY COATED INSIDE AND OUTSIDE IN ACCORDANCE WITH ANSII/AWWA C116/A21.16.
9. UNIT WEIGHT OF CONCRETE FOR VERTICAL THRUST BLOCKS IS 150 LBS/CU. FT.

THRUST BLOCKING



CITY OF BRYANT, AR
WATER UTILITIES
210 S.W. 3rd. STREET
BRYANT, AR
PHONE: (501) 943-0468

TITLE:	SEWER DETAILS		
DESCRIPTION:	FORCE MAIN THRUST BLOCKING		
DRAWN BY:	CHECKED BY:	FILE: S25-Thrust Blocking.dwg	

DATE:	APRIL 2015
	REVISED

SHEET:
S25

* CONTRACTOR WILL DRILL
2-1" HOLES IN COVER FOR
VENTING.

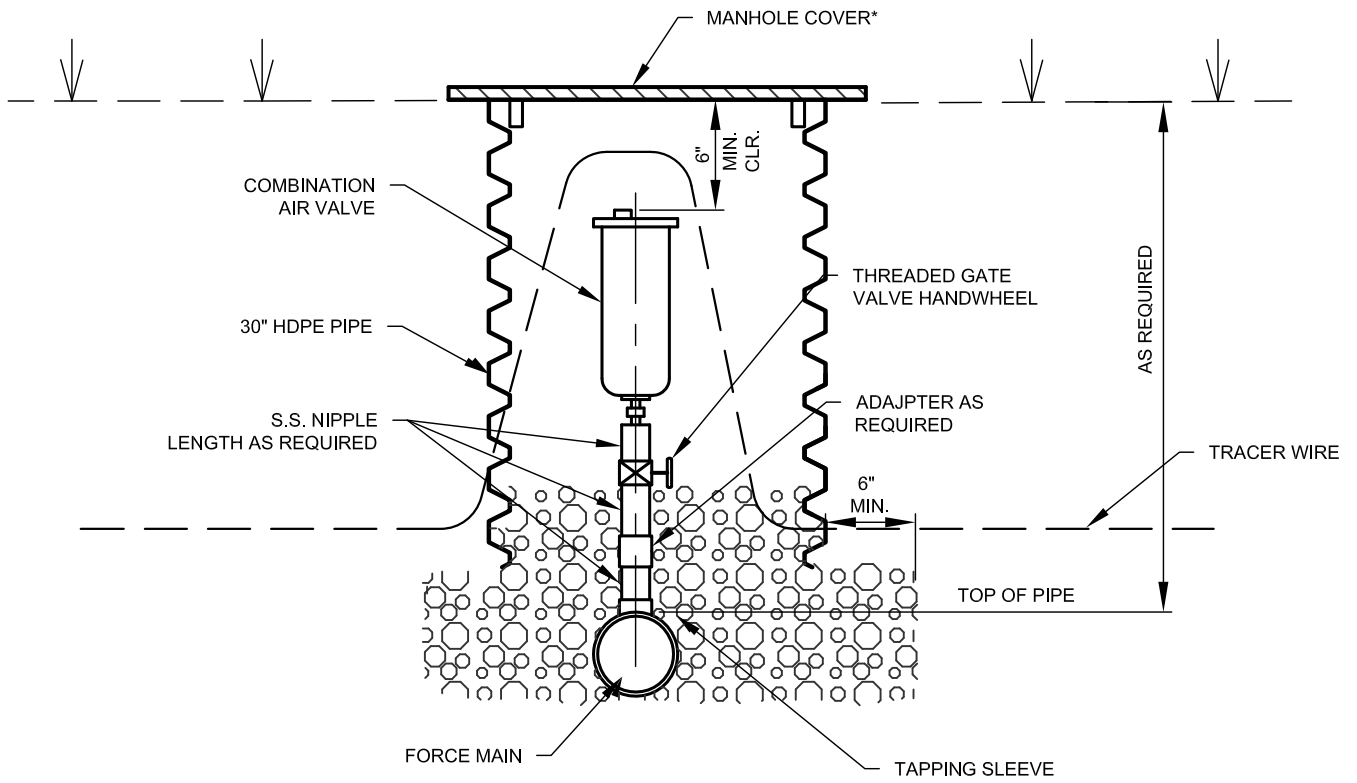

AIR RELEASE VALVE



CITY OF BRYANT, AR
 WATER UTILITIES
 210 S.W. 3rd. STREET
 BRYANT, AR
 PHONE: (501) 943-0468

TITLE:	SEWER DETAILS	
DESCRIPTION:	AIR RELEASE VALVE	
DRAWN BY:	CHECKED BY:	FILE: S26-Air Release Valve.dwg

DATE:	APRIL 2015
REVISED	----

SHEET:
S26

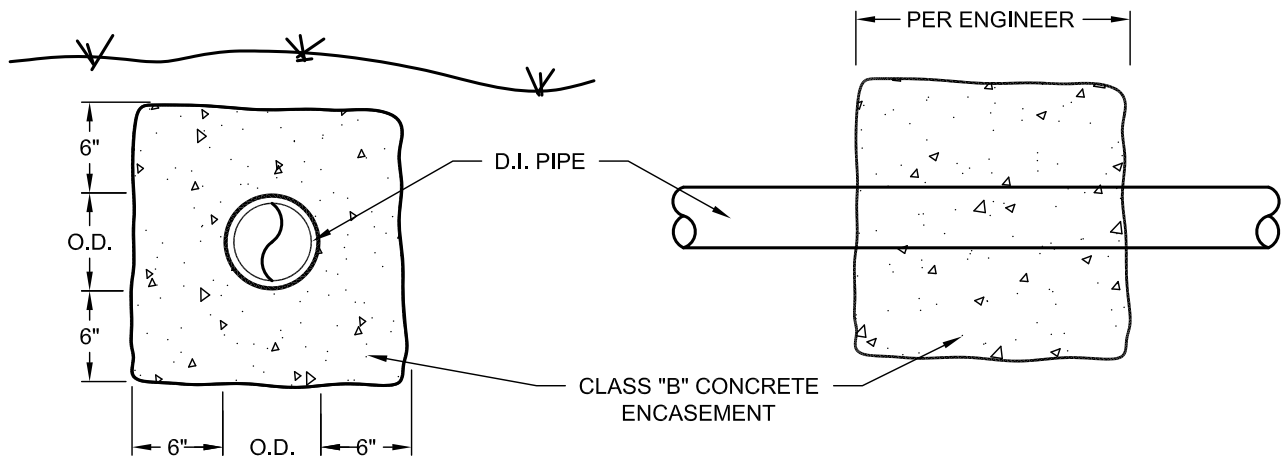

CONCRETE ENCASEMENT



CITY OF BRYANT, AR
 WATER UTILITIES
 210 S.W. 3rd. STREET
 BRYANT, AR
 PHONE: (501) 943-0468

TITLE:	SEWER DETAILS	
DESCRIPTION:	CONCRETE ENCASEMENT DETAIL	
DRAWN BY:	CHECKED BY:	FILE: S27-Concrete Encasement.dwg

DATE:	APRIL 2015
REVISED	----

SHEET:
S27

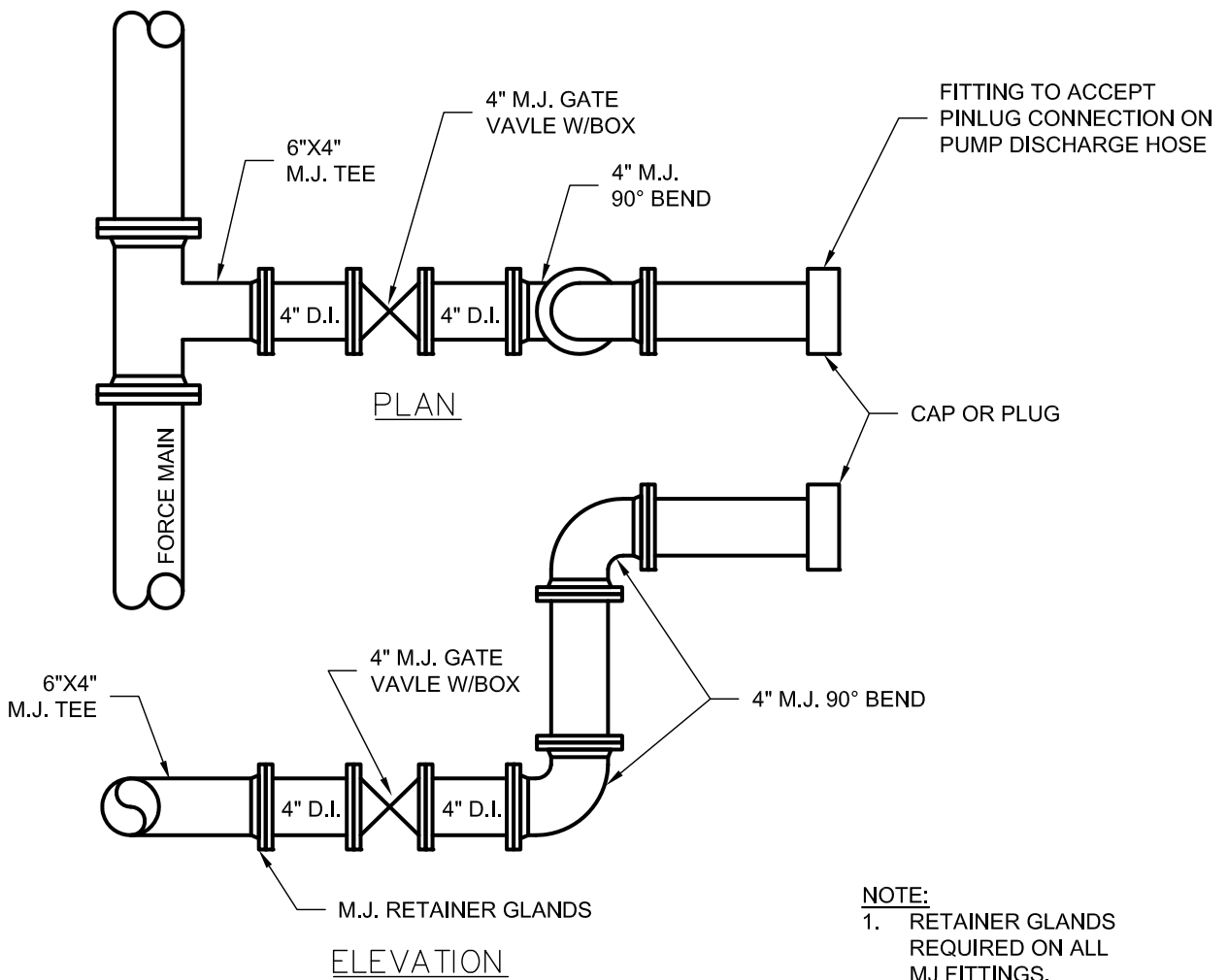

EMERGENCY PUMP CONNECTION DETAILS



CITY OF BRYANT, AR
 WATER UTILITIES
 210 S.W. 3rd. STREET
 BRYANT, AR
 PHONE: (501) 943-0468

TITLE: SEWER DETAILS		DATE: APRIL 2015	SHEET:
DESCRIPTION: EMERGENCY PUMP CONNECTION		REVISED	S28
DRAWN BY:	CHECKED BY:	----	

FILE: S28-EMERGENCY PUMP CONNECTION.dwg			

PERMITTED VALVES

1. AMERICAN FLOW CONTROL SERIES 2500
2. MUELLER SERIES 2360
3. AMERICAN AVK COMPANY SERIES 25 OR SERIES 45

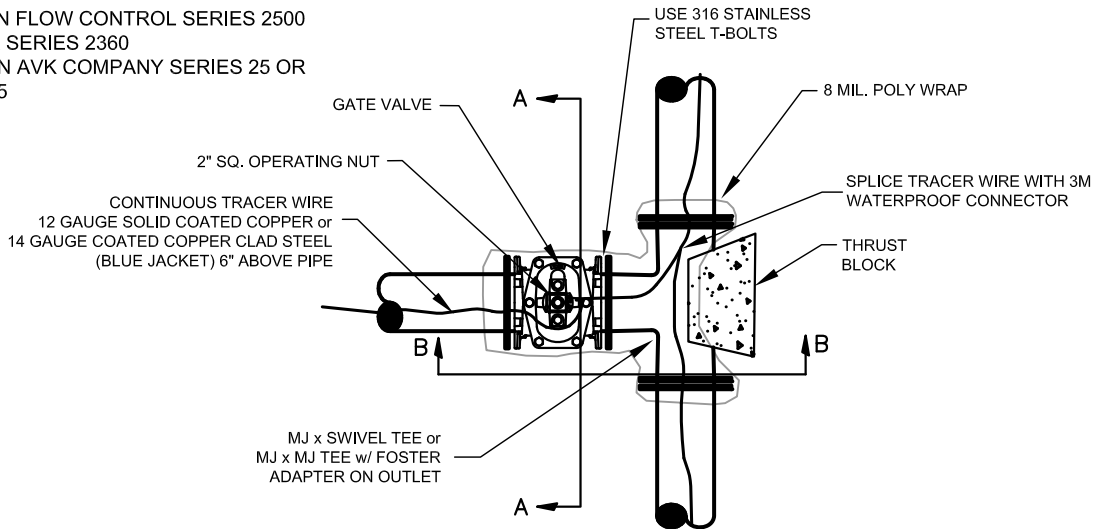

PLAN

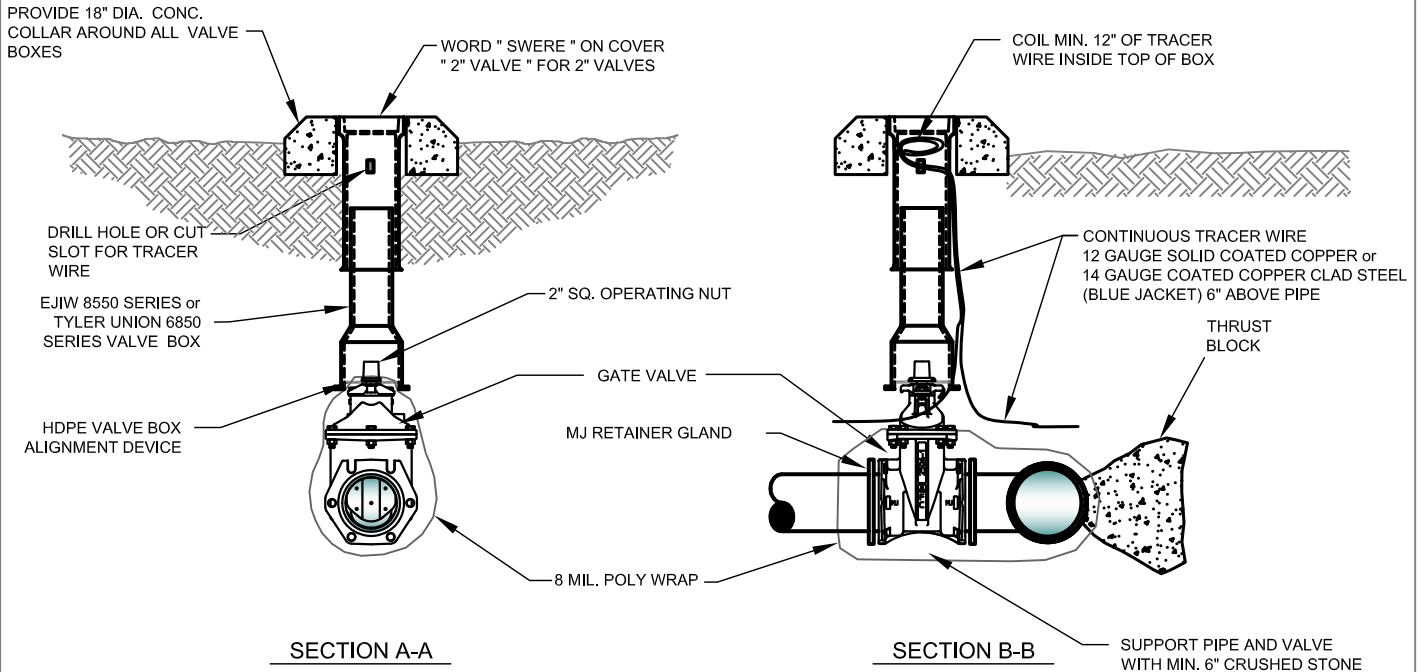

NOTES:

1. ALL VALVES SHALL BE SECURELY ANCHORED TO THE TEE.
2. ALL HARDWARE SHALL BE 316 STAINLESS STEEL.
3. IF DEPTH OF BURY EXCEEDS 4 FT., A VALVE STEM EXTENSION SHALL BE REQUIRED. THE VALVE STEM EXTENSION NUT SHALL BE WITHIN 24-INCHES TO 12-INCHES OF THE FINISHED SURFACE.

GATE VALVE DETAIL

2" - 12"



CITY OF BRYANT, AR
 WATER UTILITIES
 210 S.W. 3rd. STREET
 BRYANT, AR
 PHONE: (501) 943-0468

TITLE:	SEWER DETAILS	
DESCRIPTION:	GATE VALVE	
DRAWN BY:	CHECKED BY:	FILE: S29-Gate Valve.dwg

DATE:	APRIL 2015
	REVISED

SHEET:
S29

PERMITTED VALVES

1. AMERICAN FLOW CONTROL SERIES 2500
2. MUELLER SERIES 2360
3. AMERICAN AVK COMPANY SERIES 25 OR SERIES 45

NOTES:

1. ALL VALVES SHALL BE SECURELY ANCHORED TO THE TEE.
2. ALL HARDWARE SHALL BE 316 STAINLESS STEEL.
3. IF DEPTH OF BURY EXCEEDS 4 FT., A VALVE STEM EXTENSION SHALL BE REQUIRED. THE VALVE STEM EXTENSION NUT SHALL BE WITHIN 24-INCHES TO 12-INCHES OF THE FINISHED SURFACE.
4. A FLEX T-3 AS MANUFACTURED BY INFACOT CORPORATION MAY BE USED IN LIEU OF MJ TEE W/ FOSTER ADAPTERS.

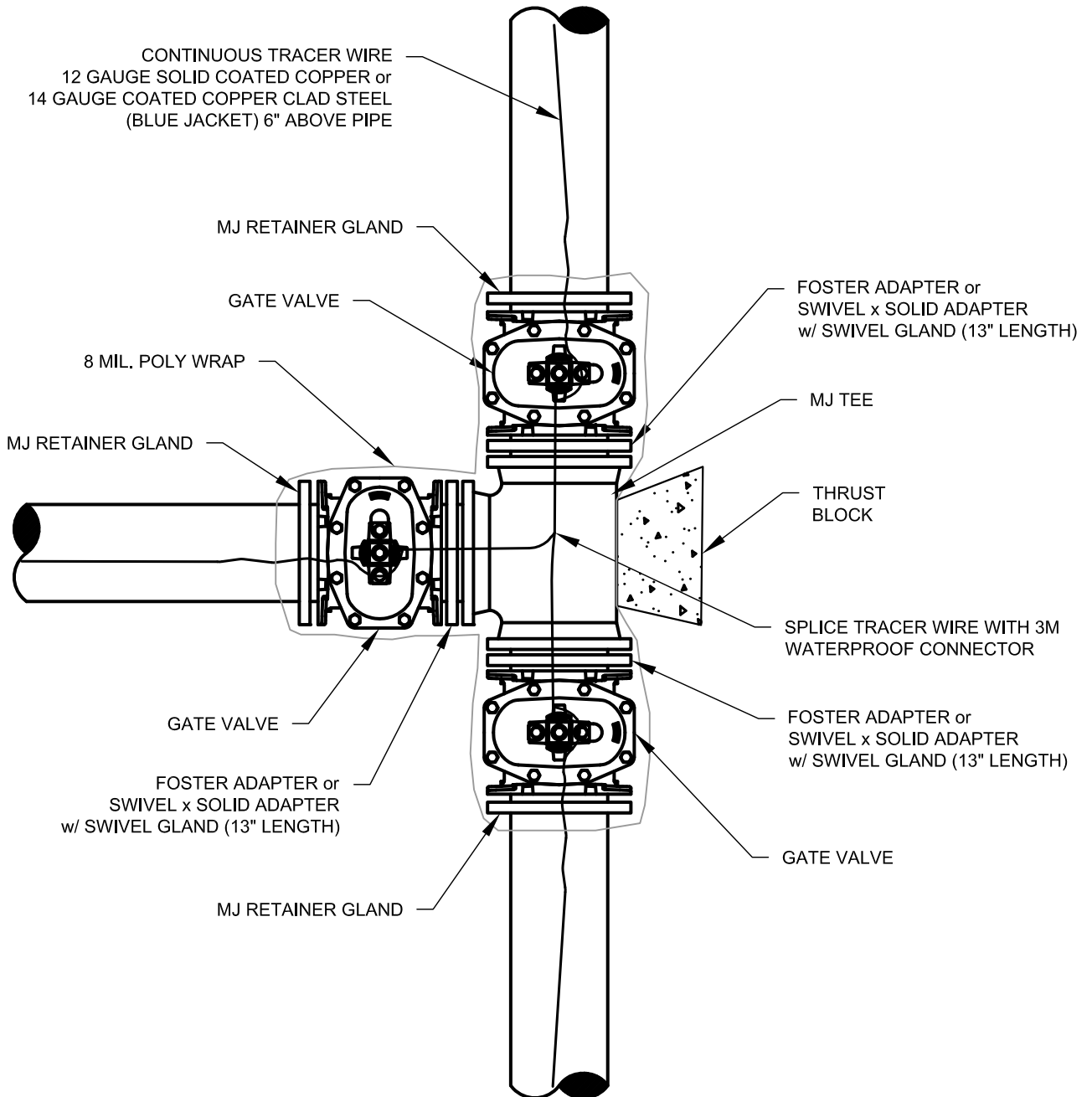

3-WAY GATE VALVE DETAIL



CITY OF BRYANT, AR
 WATER UTILITIES
 210 S.W. 3rd. STREET
 BRYANT, AR
 PHONE: (501) 943-0468

TITLE:	SEWER DETAILS	
DESCRIPTION:	3-WAY GATE VALVES	
DRAWN BY:	CHECKED BY:	FILE: S30-3-Way Gate Valves.dwg

DATE:	APRIL 2015
REVISED:	----

SHEET:
S30

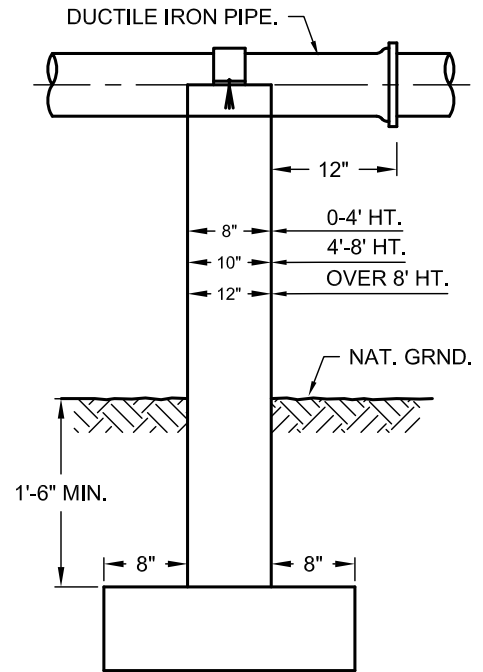
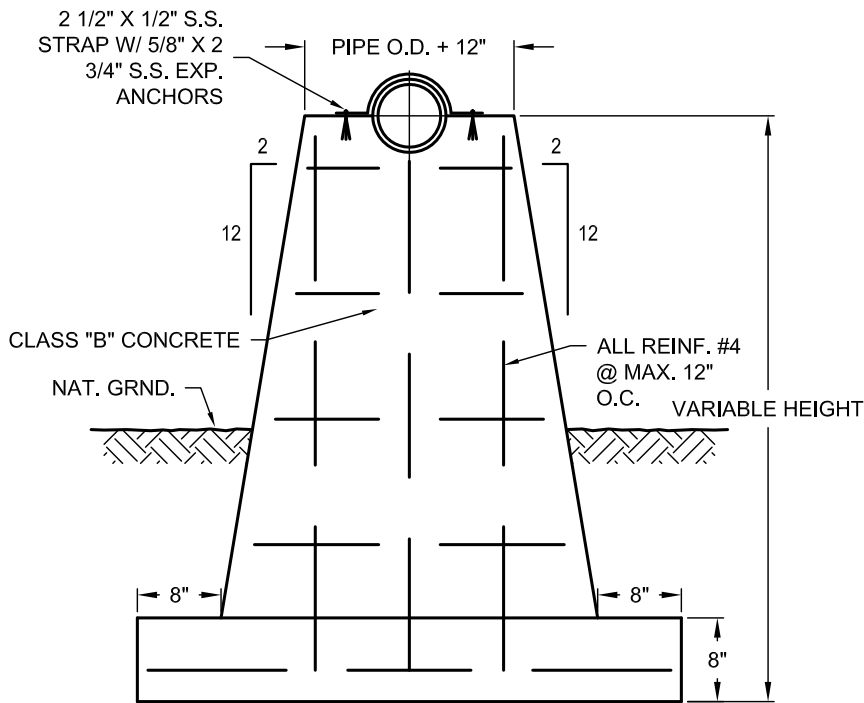

CONCRETE PIER



CITY OF BRYANT, AR
 WATER UTILITIES
 210 S.W. 3rd. STREET
 BRYANT, AR
 PHONE: (501) 943-0468

TITLE: **SEWER DETAILS**

DESCRIPTION: **CONCRETE PIER**

DRAWN BY: CHECKED BY: FILE: S31-Concrete Pier.dwg

DATE: APRIL 2015

REVISED

SHEET:

S31

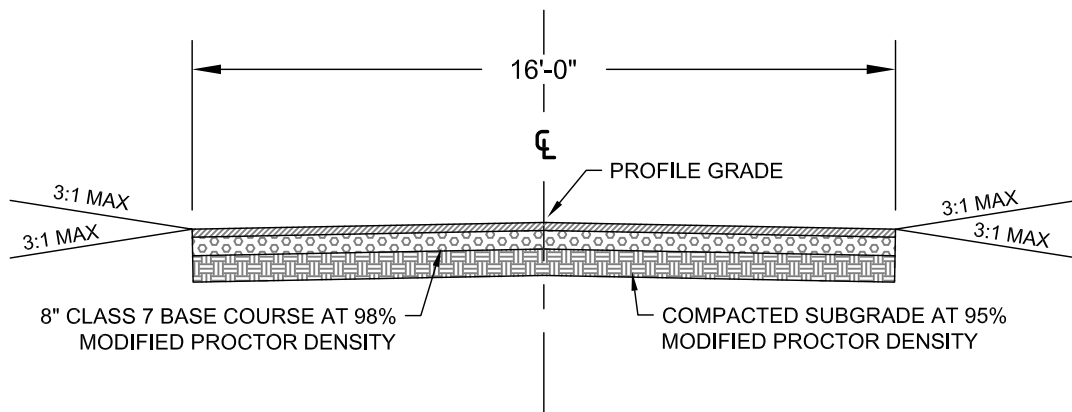

GRAVEL DRIVE FOR SEWAGE PUMP STATION

GENERAL NOTES

1. CRUSHED STONE - MATERIAL IN EACH COURSE SHALL BE COMPACTED TO A DENSITY OF 98% MAXIMUM MODIFIED DENSITY.



CITY OF BRYANT, AR
 WATER UTILITIES
 210 S.W. 3rd. STREET
 BRYANT, AR
 PHONE: (501) 943-0468

TITLE: SEWER DETAILS	
DESCRIPTION: GRAVEL DRIVE FOR SEWAGE PUMP STATION	
DRAWN BY:	CHECKED BY:
FILE: S32-Gravel Drive For Sewage Pump Station.dwg	

DATE: APRIL 2015
REVISED

SHEET:
S32

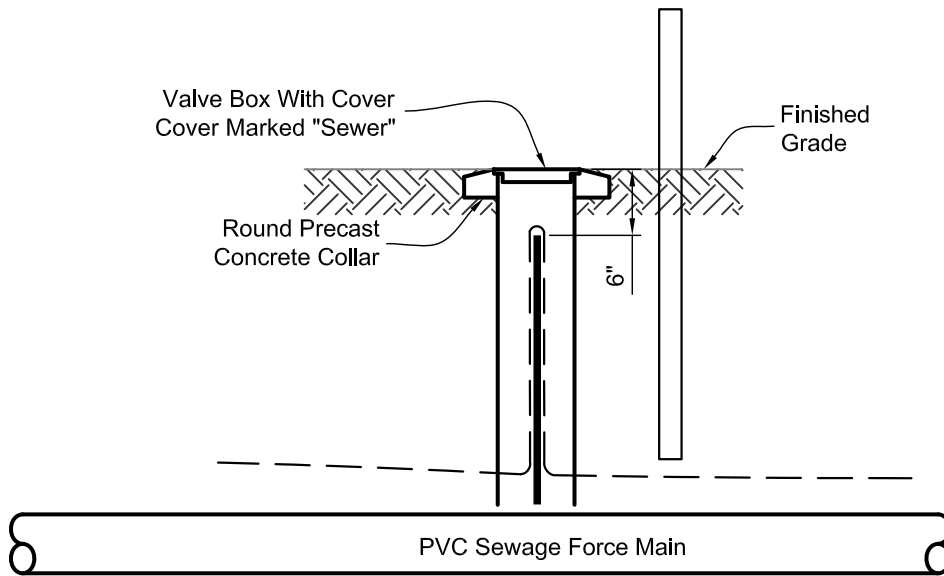

Notes:

1. Tracer Wire Test Station Shall Be Installed Every 1,000 Ft. Minimum And At Every Fiberglass Post Utility Marker.
2. Do Not Install Test Stations At Posts Located At Valves, Clean-out Stations Or Air Release Valves That Have Ground Rod Inside Access Vault

TRACER WIRE TEST STATION



CITY OF BRYANT, AR
 WATER UTILITIES
 210 S.W. 3rd. STREET
 BRYANT, AR
 PHONE: (501) 943-0468

TITLE:	SEWER DETAILS	
DESCRIPTION:	TRACER WIRE TEST STATION	
DRAWN BY:	CHECKED BY:	FILE: S33-Tracer Wire Test Station.dwg

DATE:	APRIL 2015
REVISED	----

SHEET:
S33

RESOLUTION NO. 2015-_____

RESOLUTION AUTHORIZING THE MAYOR TO ENTER INTO AN AGREEMENT TO EXCHANGE REAL ESTATE BETWEEN THE CITY OF BRYANT AND AG INVESTMENTS LLC

WHEREAS, the City of Bryant desires to make improvements on Boone Road at its intersection with Tanglewood Dr.; and

WHEREAS, the City owns Parcel 840-11625-054 located in Bryant, Saline County, Arkansas, more precisely described in Exhibit A, attached hereto; and

WHEREAS, AG Investments owns Parcel 840-15950-000, located in Bryant, Saline County, Arkansas, more precisely described in Exhibit B, attached hereto; and

WHEREAS, the City desires to exchange a portion of the said Parcel 840-11625-054, owned by the City, for a portion of the said Parcel 840-15950-000, owned by AG Investments LLC, in order to make improvements to Boone Road; and

WHEREAS, the City desires to divide said Parcel 840-11625-054 more precisely described in Exhibit A into three (3) approximately equal tracts with a twenty (20) foot easement for access and egress along the west line of said parcel to be used for a single family residence, and not manufactured housing; and

WHEREAS, AG Investments is willing to exchange a portion of Parcel 840-15950-000, more precisely described in Exhibit B for Lot 3 of Parcel 840-11625-054.

NOW THEREFORE, BE IT RESOLVED BY THE CITY COUNCIL OF THE CITY OF BRYANT, ARKANSAS THAT:

Section 1. The City the City Council of the City of Bryant hereby authorizes the Mayor to execute any and all necessary document and/or contracts for the like-kind exchange of the designated portion of Parcel 840-11625-054, owned by the City of Bryant, for the designated portion of Parcel 840-15950-000, owned by AG Investments LLC.

Section 2. Any resolution, resolution section, policy or directive in conflict with this Resolution is repealed or amended to reflect and achieve the purposes stated herein.

PASSED AND APPROVED this _____ day of _____, 2015

APPROVED:

Jill Dabbs, Mayor

Approved as to Form

ATTEST:

Sue Ashcraft, City Clerk

Richard Chris Maddison, Staff Attorney

EXHIBIT A

Parcel 840-11625-054

3.09 Acres more or less

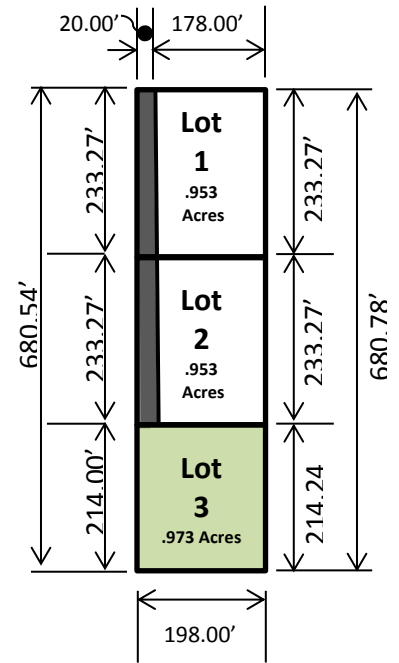
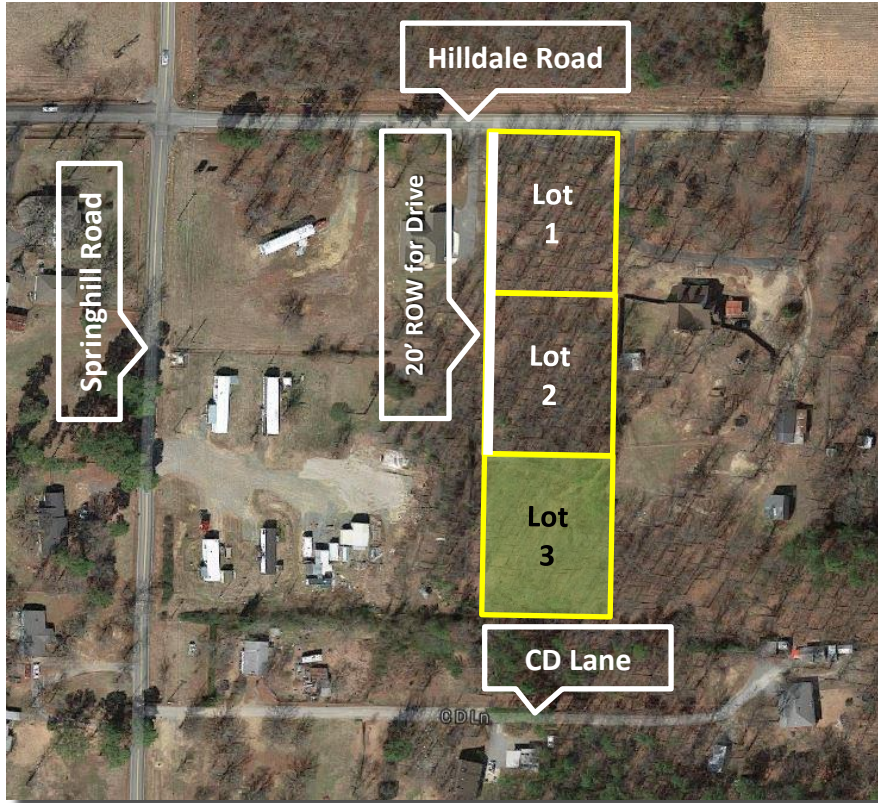

Legal Description:

All that part of the Northwest Quarter of the Northwest Quarter of Section 9, Township 1 South, Range 14 West, Saline County, Arkansas, being more fully described as follows: Commencing at the Northeast Corner of the Northwest Quarter of the Northwest Quarter of said Section 9 and run thence North 90°00'00" West along the North line of the said Northwest Quarter of the Northwest Quarter of the Northwest Quarter for a distance of 66.00 feet to the Point of Beginning of the following described tract; Run thence South 00°09'21" West for a distance of 680.78 feet; Run thence North 89°55'58" West for a distance of 198.00 feet; Run thence North 00°09'21" East to the North line of the said Northwest Quarter of the Northwest Quarter of the Northwest Quarter for a distance of 680.54 feet; Run thence North 90°00'00" East along said North line for a distance of 198.00 feet; to the Point of Beginning.

Proposal:

Divide Parcel 840-11625-054 into three approximately equal lots with a 20' right-of-way (approximately 0.211 acre) running along the west line of the parcel to provide access to the lots 2 and 3. Exchange Lot 3 for the portion of Parcel 840-15950-000 as shown on Exhibit B.

EXHIBIT B

Parcel 840-15950-000

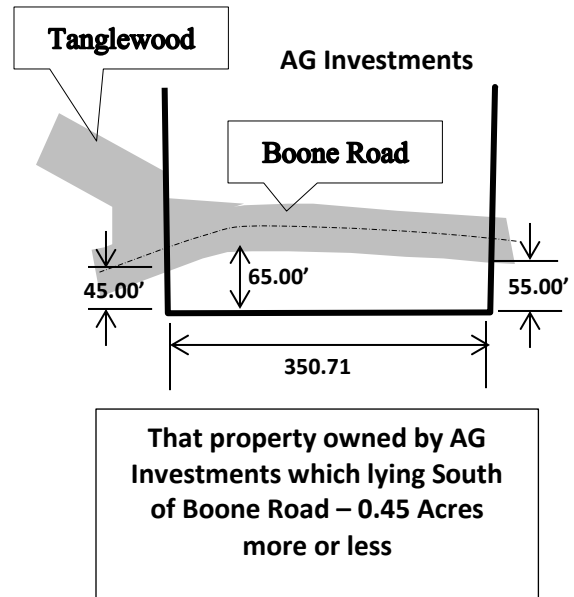
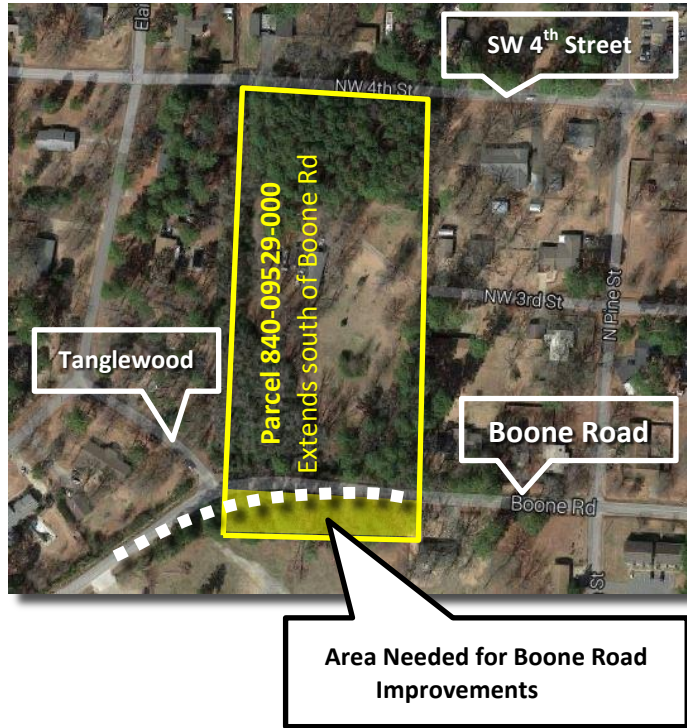

Legal Description:

As Recorded in Deed Book 92, Page 166

Part of the Northeast Quarter of the Northwest Quarter of Section 34, Township 1 South, Range 14 West, Saline County Arkansas, described as follows:
Beginning at a point 272 feet south of the Northwest Corner of said NE ¼ of the NW ¼; said Township 1 South, Range 14 West, and run thence East 352 feet;
Thence South 830 feet; thence West 350 feet to the West line of said NE ¼ of the NW ¼; thence North to the Point of Beginning, containing 5.75 acres more or less, in Saline County, Arkansas.

As Surveyed

Part of the Northeast Quarter of the Northwest Quarter of Section 34, Township 1 South, Range 14 West, Saline County Arkansas, described as follows:
Commencing at the Northwest Corner of said NE ¼ NW ¼; thence South 04°03'57" West 272.00 feet to the Point of Beginning; thence South 87°33'36" East 367.18 feet; thence South 03°26'06" West 830.07 feet; thence North 87°20'52" West 350.71 feet; thence North 00°54'27" East 152.25 feet to the Southeast Corner of Lot 21 Tanglewood Acres Subdivision; thence North 02°36'37" East along said East line of Tanglewood Acres Subdivision 676.45 feet to the Point of Beginning. Containing 6.83 acres more or less.

Subject to Right-of-Way of NW 4th Street, Boone Road, and Tanglewood Road.

ACKNOWLEDGMENT

State Of Arkansas)
) SS.
County Of Saline)

BE IT REMEMBERED, that on this day came before me, the undersigned, a notary public within and for the County aforesaid, duly commissioned and acting, Kyleen W. Hawkins to me well known as (or satisfactorily proven to be) the grantor(s) in the foregoing Deed, and acknowledged that he/she had executed the same for the consideration and purposes therein mentioned and set forth.

IN TESTIMONY WHEREOF, I have hereunto set my hand and official seal this 17th day of February, 2010.

SHERRIE D. MITCHELL
NOTARY PUBLIC-STATE OF ARKANSAS
SALINE COUNTY
My Commission Expires 1-27-2014

Sherrie D. Mitchell
Sherrie D. Mitchell, Notary Public

My commission expires
01/27/2014

THIS INSTRUMENT APPROVED BY:
SAM E. GIBSON, ATTORNEY AT LAW
P.O. BOX 211
BENTON, AR 72018
10-0150

10 012396



FILED FOR RECORD
In DC Book 10 Page 12395

FEB 18 2010
at 8:30 o'clock AM
DOUG KIDD, CIRCUIT CLERK
BY K. Holman DC

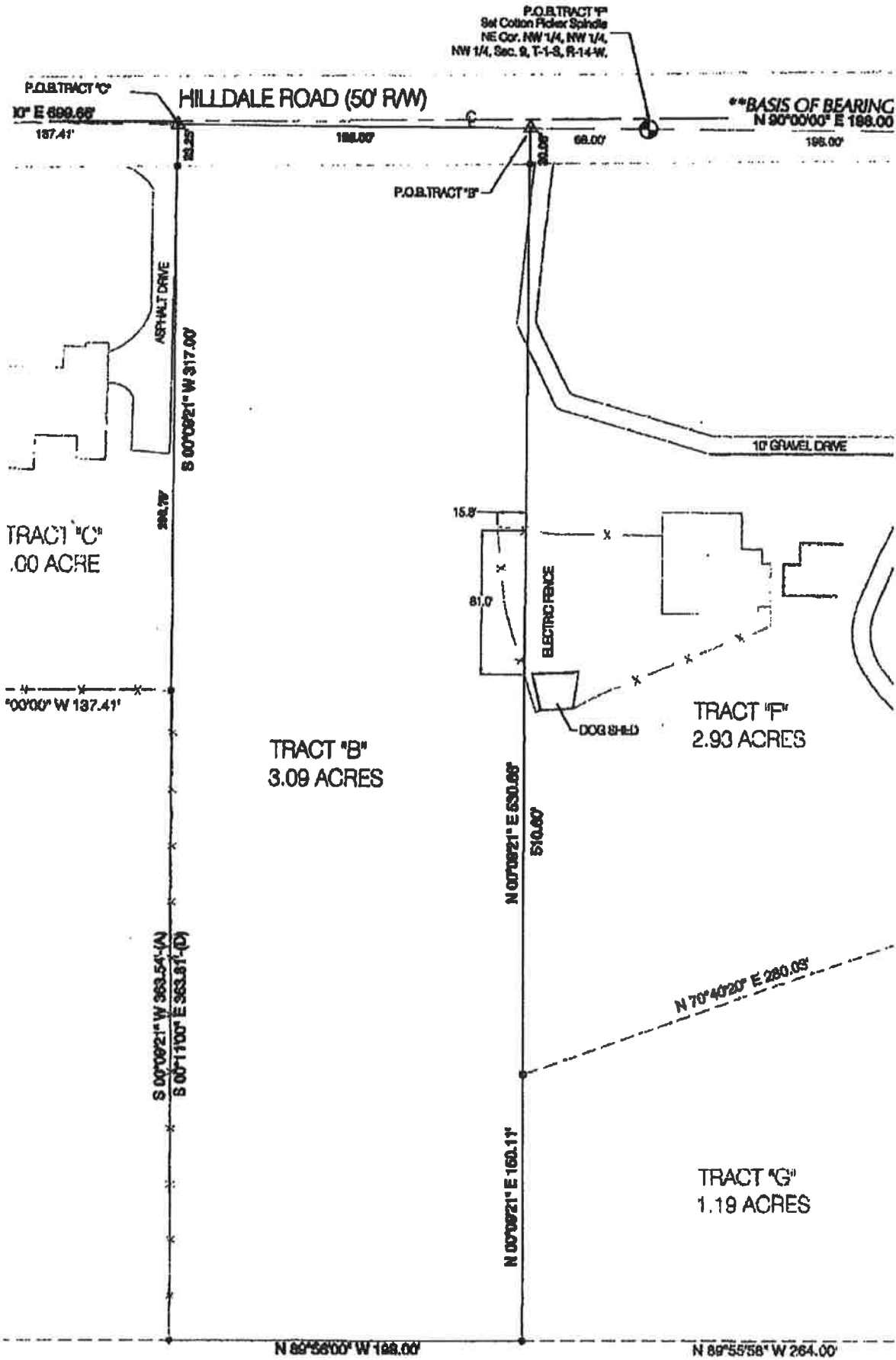

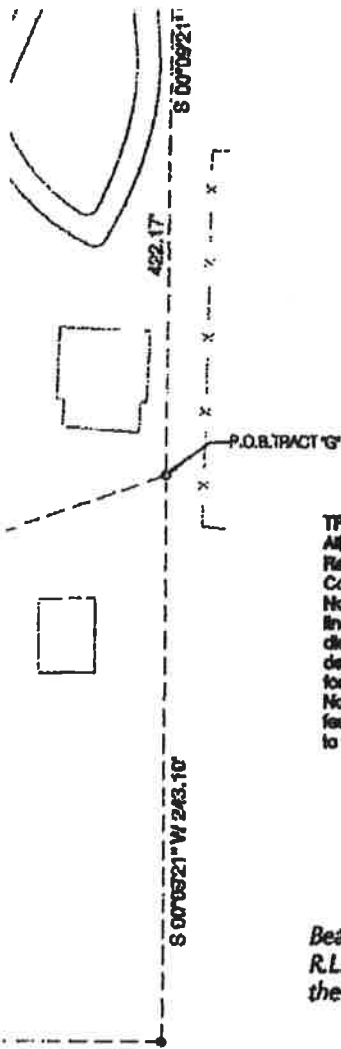



TRACT "B"

All that part of the Northwest Quarter of the Northwest Quarter of Section 9, Township 1 South, Range 14 West, Saline County, Arkansas, being more fully described as follows:
 Commencing at the Northeast Corner of the Northwest Quarter of the Northwest Quarter of said Section 9 and run thence N 89 deg. 00 min. 00 sec. W along the North line of the said Northwest Quarter of the Northwest Quarter of the Northwest Quarter for a distance of 68.00 feet to the Point of Beginning of the following described tract; run thence S 00 deg. 09 min. 21 sec. W for a distance of 680.78 feet; run thence N 89 deg. 55 min. 58 sec. W for a distance of 198.00 feet; run thence N 00 deg. 09 min. 21 sec. E to the North line of the said Northwest Quarter of the Northwest Quarter of the Northwest Quarter for a distance of 680.54 feet; run thence N 90 deg. 00 min. 00 sec. E along said North line for a distance of 198.00 feet; to the Point of Beginning Containing 3.08 acres (134770.1681 Sq. Ft.) more or less.

****BASIS OF BEARINGS:**

*Bearings are based upon a survey performed by Donald Huchingson R.L.S. #34 on April 15, 1994 whereas the North line of the NW 1/4 of the NW 1/4 of Sec. 9, T-1-S, R-14-W is N 90°00'00" W.***

<p>FOR USE AND BENEFIT OF: Kylene Hawkins</p> <p>PROPERTY ADDRESS: Hildale Road Alexander, AR 72002</p>	<p>CENTRAL ARKANSAS SURVEYING INC.</p> <p>11708 Kentz Road Little Rock, AR 72211 Phone: (501)-223-0487 Fax: (501)-223-0488 E-Mail: csa-csa@rwbell.net</p> 	
---	--	---